

OCR

Oxford Cambridge and RSA

H

Tuesday 10 November 2020 – Morning

GCSE (9–1) Combined Science (Chemistry) A (Gateway Science)

J250/09 Paper 9 (Higher Tier)

Time allowed: 1 hour 10 minutes

You must have:

- a ruler (cm/mm)
- the Data Sheet for GCSE (9–1) Combined Science (Chemistry) A (inside this document)

You can use:

- a scientific or graphical calculator
- an HB pencil



Please write clearly in black ink. **Do not write in the barcodes.**

Centre number

--	--	--	--	--

Candidate number

--	--	--	--

First name(s) _____

Last name _____

INSTRUCTIONS

- Use black ink. You can use an HB pencil, but only for graphs and diagrams.
- Write your answer to each question in the space provided. If you need extra space use the lined pages at the end of this booklet. The question numbers must be clearly shown.
- Answer **all** the questions.
- Where appropriate, your answer should be supported with working. Marks might be given for using a correct method, even if your answer is wrong.

INFORMATION

- The total mark for this paper is **60**.
- The marks for each question are shown in brackets [].
- Quality of extended response will be assessed in questions marked with an asterisk (*).
- This document has **24** pages.

ADVICE

- Read each question carefully before you start your answer.

2
SECTION A

Answer **all** the questions.

You should spend a maximum of 20 minutes on this section.

Write your answer to each question in the box provided.

- 1 Iron can be made from the reaction of iron(III) oxide with carbon monoxide.

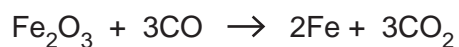

What is the **reducing agent** in this reaction?

- A CO
- B CO₂
- C Fe
- D Fe₂O₃

Your answer

[1]

- 2 Look at the information about a nitrogen atom.

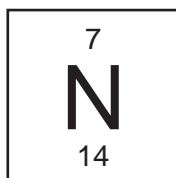

How many **electrons** are in a nitride ion, N³⁻?

- A 4
- B 10
- C 11
- D 17

Your answer

[1]

3

3 Relative atomic mass compares the average mass of an atom to which element?

- A Carbon
- B Hydrogen
- C Nitrogen
- D Oxygen

Your answer

[1]

4 Which statement describes a covalent bond?

- A A shared pair of electrons.
- B The electrostatic attraction between oppositely charged ions.
- C The electrostatic attraction between delocalised electrons and positive ions.
- D The forces of attraction between molecules.

Your answer

[1]

4

5 The atomic model has changed over time.

Look at the diagrams.

They show four different atomic models and the years they were developed.

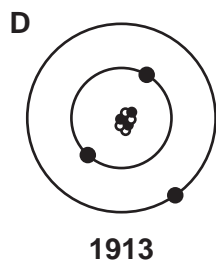
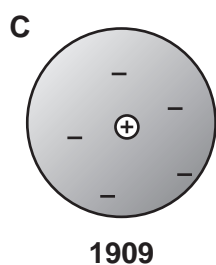
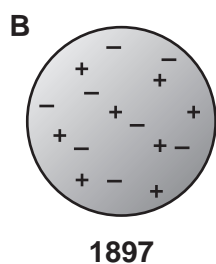
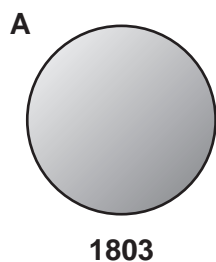

Which atomic model was developed by Niels Bohr?

Your answer

[1]

5

6 The particle model used to describe solids, liquids and gases has some limitations.

Which of the following is **not** a limitation of the particle model?

- A The forces of attraction between particles.
- B The number of the particles.
- C The size of the particles.
- D The space between the particles.

Your answer

[1]

7 What is the number of atoms in 0.0485 moles of carbon?

The Avogadro constant = 6.02×10^{23} .

- A 8.05×10^{-26}
- B 2.92×10^{22}
- C 6.02×10^{23}
- D 1.24×10^{25}

Your answer

[1]

6

8 Which curve shows how the pH of a strong alkali changes when a strong acid is added?

A

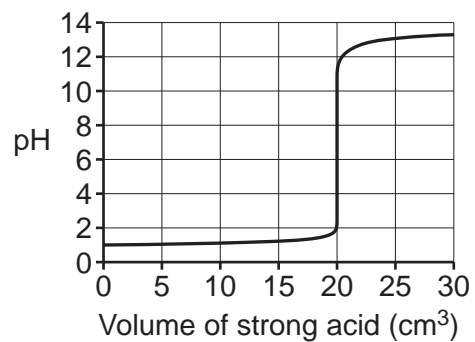

B

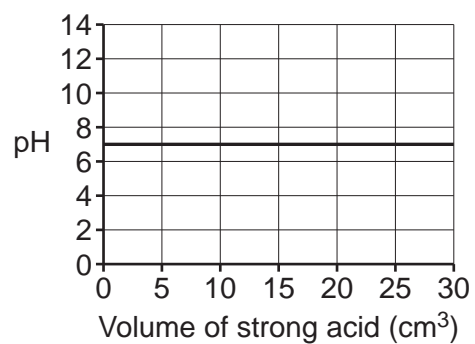

C

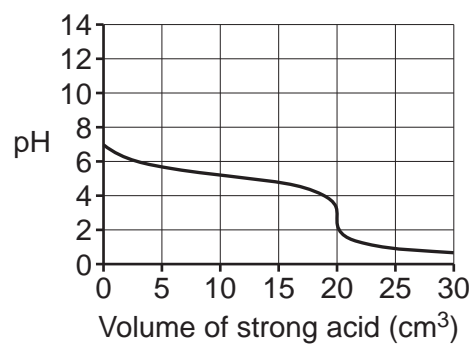

D

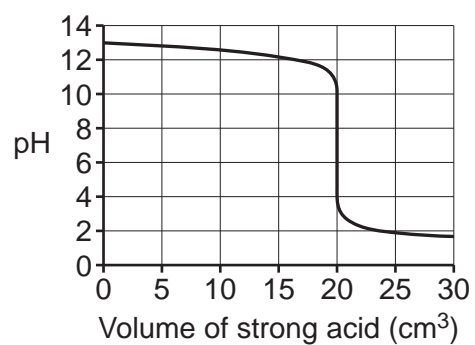

Your answer

[1]

7

9 Which ionic equation is balanced correctly?

- A $2\text{Ag}^+ + \text{CO}_3^{2-} \rightarrow \text{Ag}_2\text{CO}_3$
- B $\text{Al}^{3+} + 3\text{OH}^- \rightarrow \text{Al}(\text{OH})_3$
- C $\text{Ba}^{2+} + \text{SO}_4^{2-} \rightarrow \text{Ba}_2(\text{SO}_4)_2$
- D $2\text{Pb}^{2+} + \text{NO}_3^- \rightarrow \text{Pb}_2\text{NO}_3$

Your answer

[1]

10 A student dissolves 5×10^{-3} moles of sodium hydroxide, NaOH, in 250 cm^3 of water.

What is the mass of sodium hydroxide in 25 cm^3 of the solution?

Relative formula mass, M_r , of NaOH = 40.0

- A $5 \times 10^{-2} \text{ g}$
- B 0.02 g
- C 2 g
- D 4 g

Your answer

[1]

8
SECTION B

Answer **all** the questions.

- 11 People use perfumes to make them smell nice.

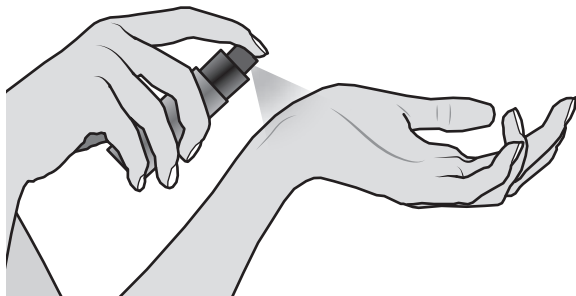

Look at the table. It shows the percentages of the different ingredients in a perfume.

Ingredient	Percentage (%)
fragrance	5.2
alcohol	74.8
colour	0.5
UV filter	0.5
water	added to make up to 100%

- (a) What is the name given to a mixture, such as perfume, where the ingredients are combined in exact amounts?

..... [1]

- (b) A bottle contains 25 g of the perfume.

Calculate the mass of water in 25 g of the perfume.

Mass of water in 25 g of perfume = [2]

(c) When the perfume is sprayed onto the skin, the alcohol evaporates very quickly.

(i) Suggest why the alcohol evaporates very quickly.

.....
..... [1]

(ii) As the alcohol evaporates, the skin starts to feel cold.

Explain why.

Use ideas about energy in your answer.

.....
.....
.....
..... [2]

10

12 This question is about compounds of magnesium.

(a) Magnesium hydroxide contains magnesium ions, Mg^{2+} , and hydroxide ions, OH^- .

Write the **formula** of magnesium hydroxide.

..... [1]

(b) Magnesium carbonate, MgCO_3 , reacts with dilute hydrochloric acid, HCl .

Magnesium chloride, MgCl_2 , water and carbon dioxide are made.

Write the **balanced symbol equation** for the reaction.

..... [2]

(c) A compound of magnesium contains an unknown element, **X**.

X is an element found in Group 7 of the Periodic Table.

The compound has the formula MgX_2 .

The relative formula mass of the MgX_2 is 184.1.

(i) Calculate the relative atomic mass of **X**.

$A_r \text{ Mg} = 24.3$

Relative atomic mass of **X** = [2]

(ii) Identify element **X**.

Use the Periodic Table on the Data Sheet to help you.

..... [1]

13 Hydrogen, H_2 , and chlorine, Cl_2 , react to make hydrogen chloride, HCl .

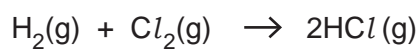

The reaction is exothermic.

(a) Look at **Fig. 13.1**. It shows the reaction profile for the reaction.

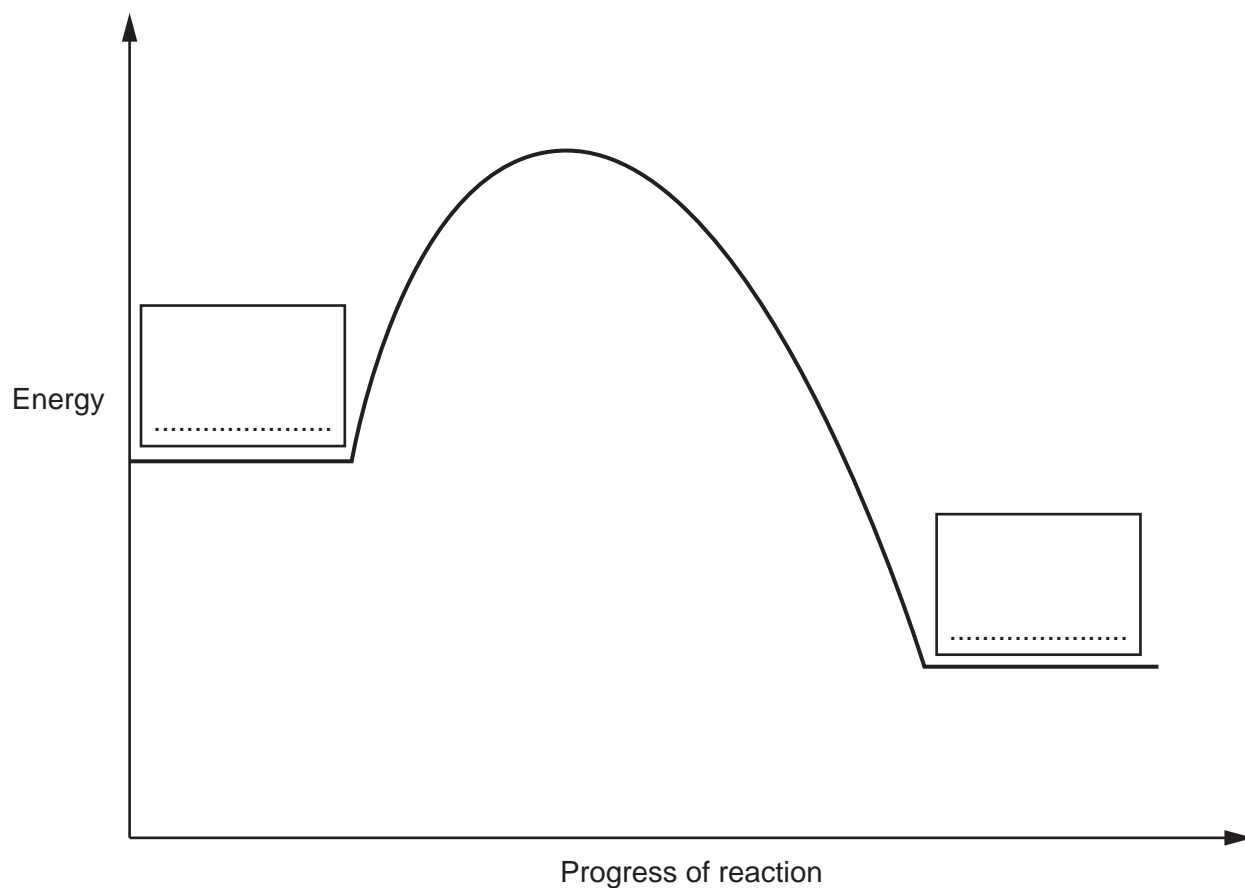

Fig. 13.1

Complete **Fig. 13.1** by filling in the **two** boxes.

Use the **balanced symbol equation** to help you.

[2]

12

(b) Fig. 13.2 shows three energy changes, **A**, **B** and **C**, for a reaction.

The energy released in the reaction is 102 kJ/mol.

The activation energy for the reaction is 142 kJ/mol.

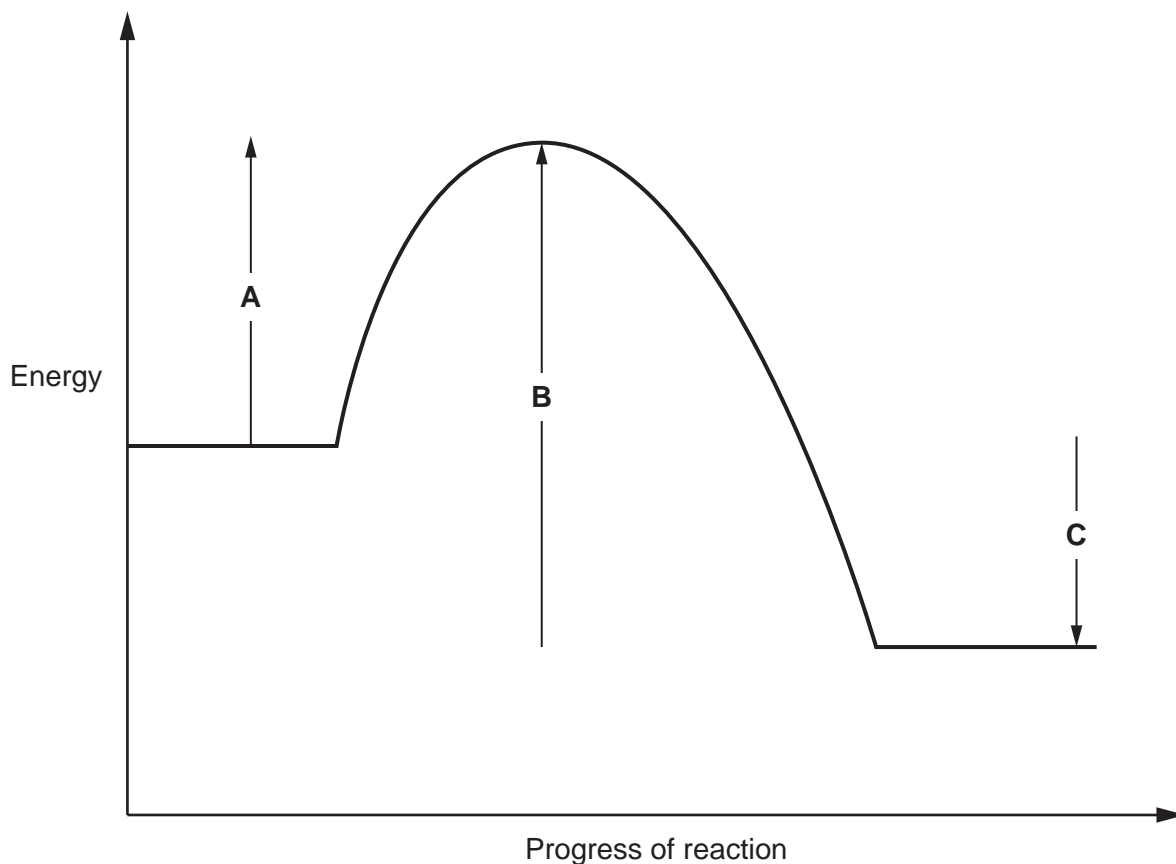

Fig. 13.2

Complete the table to identify:

- Which arrow, **A**, **B** or **C**, shows the energy released in the reaction, 102 kJ/mol.
- Which arrow, **A**, **B** or **C**, shows the activation energy for the reaction, 142 kJ/mol.

Tick (✓) **one** box in each row.

	A	B	C
Energy released 102 kJ/mol			
Activation energy 142 kJ/mol			

[2]

13
BLANK PAGE

PLEASE DO NOT WRITE ON THIS PAGE

Turn over for question 14

14

14 A student investigates how to make a sample of a pure salt.

His method is shown in **Fig. 14.1**.

Stage 1 React an excess of copper oxide with 50 cm³ dilute hydrochloric acid.

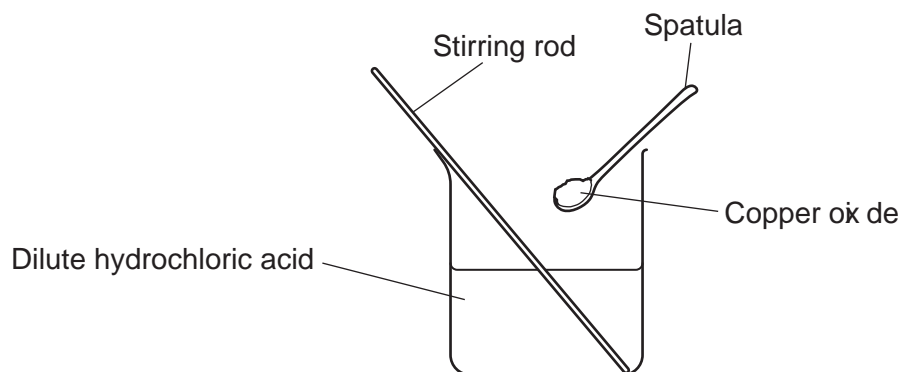

Stage 2 Heat the solution from Stage 1.

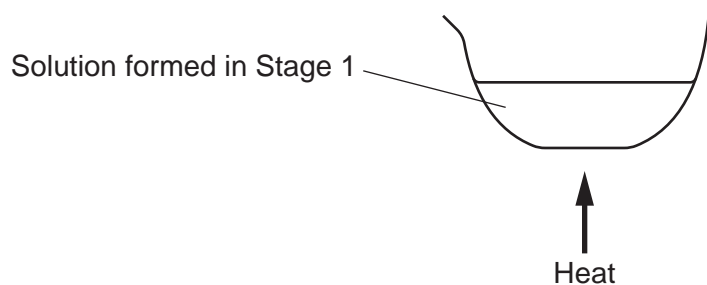

Fig. 14.1

(a) Copper oxide is an **insoluble** compound that neutralises dilute hydrochloric acid.

Name the type of insoluble compound that neutralises an acid to form a salt and water.

..... [1]

(b) Dilute hydrochloric acid is a **hazardous** chemical.

Describe **one** safety precaution the student should take when using dilute hydrochloric acid.

..... [1]

(c) Stage 1 uses an **excess** of copper oxide.

Give a reason why.

.....

..... [1]

15

- (d) The equation shows the reaction between copper oxide, CuO, and dilute hydrochloric acid, HCl.



The student adds 0.500 g of copper oxide to the 50 cm³ of dilute hydrochloric acid.

The 50 cm³ contains 2.50×10^{-3} moles of hydrochloric acid.

- (i) Calculate the number of moles of copper oxide, CuO, in 0.500 g.

Give your answer to **3** significant figures.

Number of moles of copper oxide = mol **[3]**

- (ii) Use your answer to **(d)(i)** and the balanced symbol equation to explain why the copper oxide is in excess.

.....

 **[2]**

- (e) Another student thinks that the method in **Fig. 14.1** will not make pure copper chloride.

- (i) Explain why this student is correct.

.....
 **[1]**

- (ii) Describe how the method in **Fig. 14.1** can be improved to make **pure** copper chloride.

.....
 **[1]**

16

15* Diamond and chlorine are both covalently bonded.

The table shows the melting points of two substances, **X** and **Y**.

Substance	Melting point (°C)
X	3550
Y	-102

A student thinks that substance **X** is diamond and substance **Y** is chlorine.

Is the student correct?

Explain your answer using ideas about the structure and bonding in both diamond and chlorine.

.....
.....
.....
.....
.....
.....
.....
.....
.....
.....
.....
.....
.....
.....
.....

..... [6]

17
BLANK PAGE

PLEASE DO NOT WRITE ON THIS PAGE

Turn over for question 16

16 Phosphoric acid, H_3PO_4 , is a strong acid.

A student investigates how the pH of a solution of dilute phosphoric acid changes when a solution of calcium hydroxide is slowly added to it from a burette.

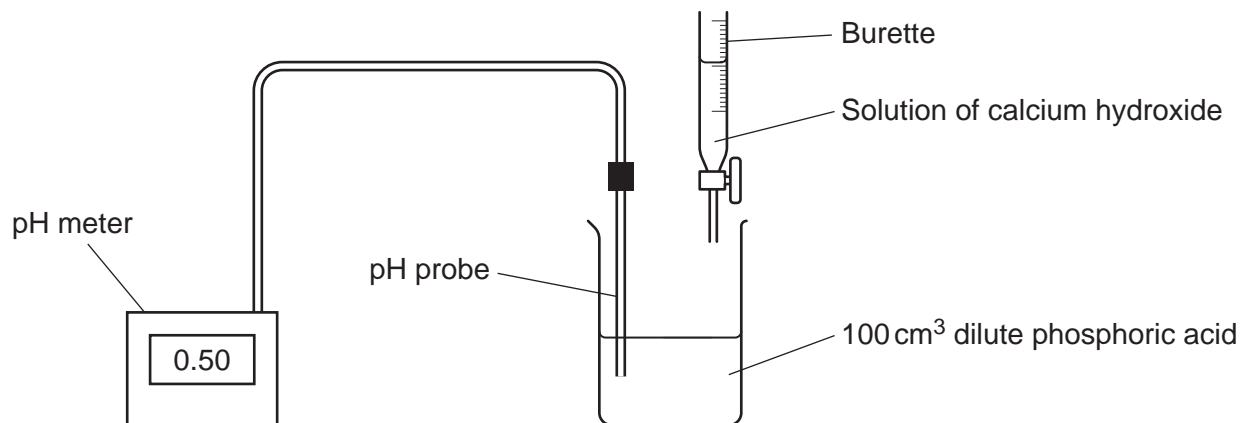

The student then calculates the concentration of hydrogen ions as the pH changes.

Table 16.1 shows the results of her experiment.

pH of solution formed	Concentration of hydrogen ions as the pH changes (mol/dm^3)
0.50	0.320
1.00	0.100
1.50	0.032
2.00	0.010

Table 16.1

(a) Explain why phosphoric acid is described as a **strong** acid.

.....
 [1]

(b) Explain why the solution of phosphoric acid used is described as **dilute**.

.....
 [1]

(c) Complete the **balanced symbol** equation for the reaction between phosphoric acid and calcium hydroxide.

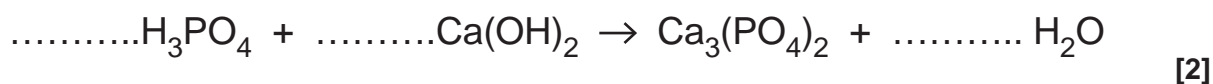

(d) Look at **Table 16.1**.

Describe how the pH of the solution formed changes as the concentration of the hydrogen ions in the solution changes by a factor of 10.

Use data from **Table 16.1** in your answer.

.....

.....

.....

..... [2]

(e) The reaction between phosphoric acid and calcium hydroxide is a neutralisation reaction.

Write the **balanced ionic equation** for neutralisation.

Include state symbols.

..... [2]

- 17 Potassium chloride, KCl , is an ionic compound containing potassium ions, K^+ , and chloride ions, Cl^- .

Potassium chloride can be electrolysed when it is a molten liquid, $KCl(l)$, or an aqueous solution, $KCl(aq)$.

Electrolysis of potassium chloride, $KCl(l)$ forms:

- potassium at the cathode
- chlorine at the anode.

- (a) Explain the term **electrolysis**.

.....
.....
..... [2]

- (b) Electrolysis involves the reactions of cations and anions.

Describe the difference between cations and anions.

.....
..... [1]

- (c) The electrolysis of molten potassium chloride makes potassium at the cathode.

- (i) Write the **balanced half equation** for the formation of potassium.

..... [1]

- (ii) State and explain if this equation shows oxidation or reduction.

.....
.....
..... [2]

21

- (d) Name the product formed at the **cathode** when an aqueous solution of potassium chloride, $KCl(aq)$, is electrolysed.

Give a reason for your answer.

.....
.....
..... [2]

- (e) Name the product formed at the **anode** when an aqueous solution of potassium chloride, $KCl(aq)$, is electrolysed.

Give a reason for your answer.

.....
.....
..... [2]

END OF QUESTION PAPER

ADDITIONAL ANSWER SPACE

If additional space is required, you should use the following lined page(s). The question number(s) must be clearly shown in the margin(s).

A large rectangular area with a vertical solid line on the left side and horizontal dotted lines across the rest of the page, providing space for writing answers.

A large rectangular area with a solid vertical line on the left side and horizontal dotted lines extending across the page, providing a template for writing.

A large rectangular area with a vertical line on the left side and horizontal dotted lines across the rest of the page, intended for writing answers.

OCR
Oxford Cambridge and RSA

Copyright Information

OCR is committed to seeking permission to reproduce all third-party content that it uses in its assessment materials. OCR has attempted to identify and contact all copyright holders whose work is used in this paper. To avoid the issue of disclosure of answer-related information to candidates, all copyright acknowledgements are reproduced in the OCR Copyright Acknowledgements Booklet. This is produced for each series of examinations and is freely available to download from our public website (www.ocr.org.uk) after the live examination series. If OCR has unwittingly failed to correctly acknowledge or clear any third-party content in this assessment material, OCR will be happy to correct its mistake at the earliest possible opportunity.

For queries or further information please contact The OCR Copyright Team, The Triangle Building, Shaftesbury Road, Cambridge CB2 8EA.

OCR is part of the Cambridge Assessment Group; Cambridge Assessment is the brand name of University of Cambridge Local Examinations Syndicate (UCLES), which is itself a department of the University of Cambridge.