



Cambridge IGCSE™

CANDIDATE
NAME

CENTRE
NUMBER

--	--	--	--	--

CANDIDATE
NUMBER

--	--	--	--



CO-ORDINATED SCIENCES

0654/32

Paper 3 Theory (Core)

October/November 2023

2 hours

You must answer on the question paper.

No additional materials are needed.

INSTRUCTIONS

- Answer **all** questions.
- Use a black or dark blue pen. You may use an HB pencil for any diagrams or graphs.
- Write your name, centre number and candidate number in the boxes at the top of the page.
- Write your answer to each question in the space provided.
- Do **not** use an erasable pen or correction fluid.
- Do **not** write on any bar codes.
- You may use a calculator.
- You should show all your working and use appropriate units.

INFORMATION

- The total mark for this paper is 120.
- The number of marks for each question or part question is shown in brackets [].
- The Periodic Table is printed in the question paper.

This document has **32** pages. Any blank pages are indicated.

1 (a) Fig. 1.1 is a diagram of a marine food web.

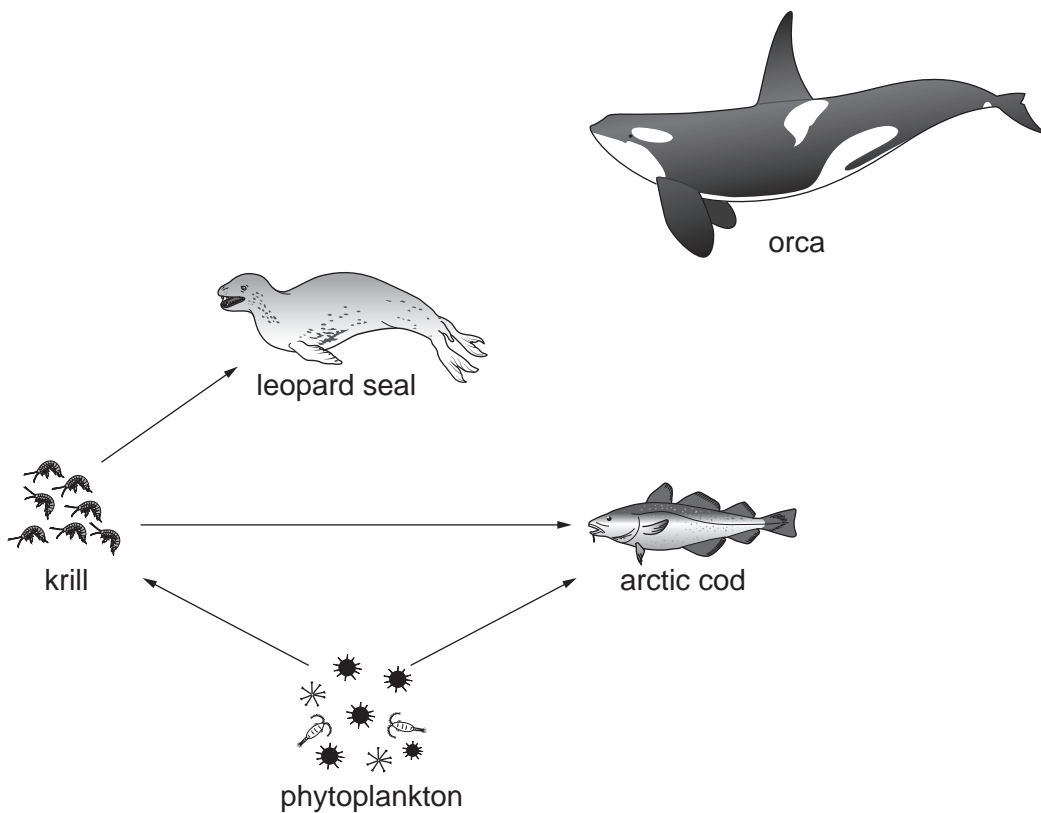

Fig. 1.1

Table 1.1 shows terms used to describe the organisms in Fig. 1.1.

Place ticks (✓) in the boxes to show the term(s) used to describe each organism.

Table 1.1

organism	herbivore	producer	primary consumer	secondary consumer
arctic cod				
krill				
phytoplankton				
leopard seal				

[4]

(b) An orca eats arctic cod and leopard seal.

Add this information to the food web in Fig. 1.1.

[1]

(c) State the principal source of energy for all food chains.

..... [1]

3

(d) The process of photosynthesis occurs in some marine organisms.

(i) State the word equation for photosynthesis.

..... [2]

(ii) State the name of the cell structure where photosynthesis occurs.

..... [1]

[Total: 9]

- 2 (a) Chlorine, bromine and iodine are halogens in Group VII of the Periodic Table.

Some of these statements about the halogens are correct and some are incorrect.

Place a tick (✓) in the boxes next to the correct statements.

the halogens are elements

the halogens exist as diatomic molecules

the halogens form covalent molecules with metals

the reactivity of the halogens increases down the group

[2]

- (b) A chlorine atom has a nucleon number of 37 and has 17 electrons.

- (i) Determine the number of protons and the number of neutrons in this chlorine atom.

number of protons =

number of neutrons =

[2]

- (ii) State the part of the atom that contains the protons and neutrons.

..... [1]

- (c) Chlorine is made during the electrolysis of concentrated aqueous sodium chloride as shown below in Fig. 2.1.

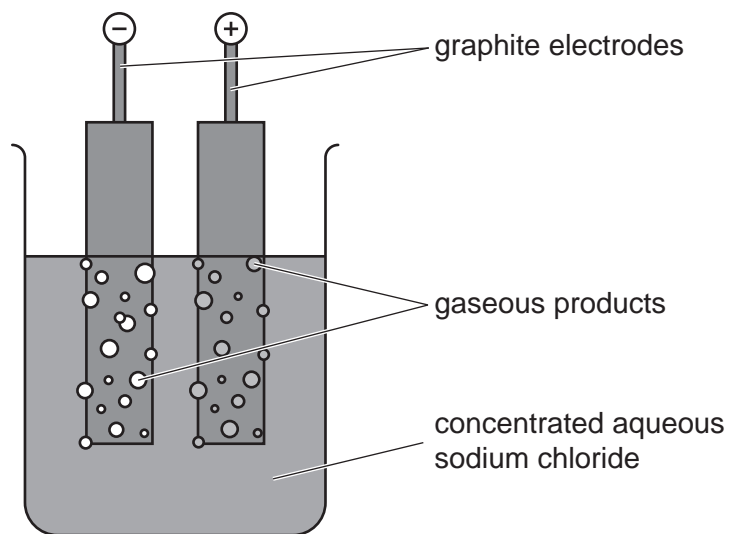

Fig. 2.1

- (i) State the electrode at which chlorine forms during this process.
 [1]
- (ii) State the other **gaseous** product of this electrolysis.
 [1]
- (iii) Explain why graphite is used to make the electrodes.
 [1]
- (iv) Explain why electrolysis is an example of a chemical change and **not** a physical change.

 [1]
- (d) Explain why the drinking water supply for a town is treated with chlorine.

 [1]

[Total: 10]

- 3 (a) Fig. 3.1 shows a stationary car.



Fig. 3.1

Part of each tyre is in contact with the road.

State the **two** quantities needed to calculate the pressure exerted by the car on the road.

1

2

[2]

- (b) (i) Many car wheels are made from either steel or an aluminium alloy.

Describe a simple test to show that a wheel is **not** made from steel.

.....
..... [2]

- (ii) The car driver loosens the wheel nuts.

He puts a spanner on a wheel nut as shown in Fig. 3.2.

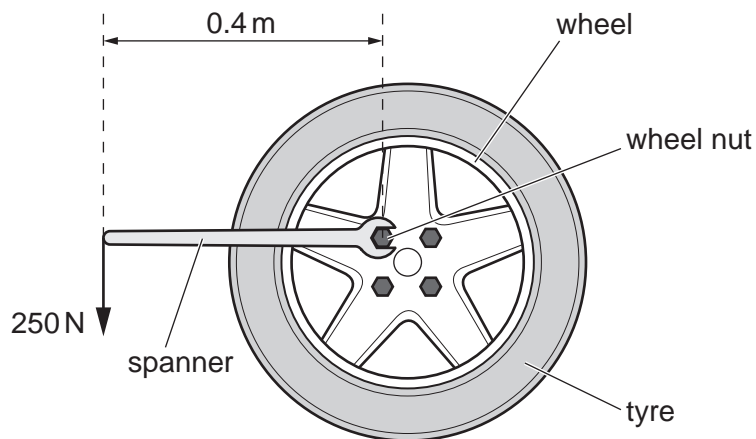

Fig. 3.2

The driver applies a force of 250 N at a distance of 0.4 m from the wheel nut.

Calculate the moment of the force about the centre of the wheel nut.

moment of force = Nm [2]

- (iii) The car driver uses a pump powered by an electric motor to inflate the tyre.

The turning effect of an electric motor can be increased by increasing the number of turns on the coil in the motor.

State **one** other way to increase the turning effect of a d.c. motor.

..... [1]

8

(c) Fig. 3.3 shows the car travelling along a road.

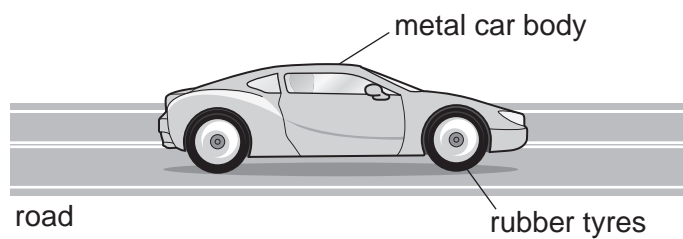

Fig. 3.3

As the car moves along the road, electrostatic charges build up on the car.

Complete the sentences.

The force that causes the build-up of electrostatic charges on the car is

The charged particles that are added or removed during the build-up of charge are called

.....

[2]

[Total: 9]

BLANK PAGE

4 (a) Polydactyly is a condition that results in the growth of extra fingers or toes.

The allele for polydactyly is dominant **D**.

The allele for **no** polydactyly is recessive **d**.

Table 4.1 shows the genotypes of one family.

Table 4.1

parent A	parent B	offspring Q	offspring R	offspring S	offspring T	offspring U
Dd	Dd	Dd	dd	Dd	dd	DD

State the number of people in Table 4.1:

with polydactyly

with a heterozygous genotype

[2]

(b) The parents in Table 4.1 have another child.

Complete the genetic diagram in Fig. 4.1 to show the percentage likelihood of the offspring **not** having polydactyly.

		parent A gametes	
		D	d
parent B gametes	D		
	d		

percentage likelihood of the offspring **not** having polydactyly%

Fig. 4.1

[2]

(c) Genes and chromosomes are involved in inheritance.

(i) Define the term gene.

.....
..... [2]

(ii) State the sex chromosomes present in the body cells of human males.

..... [1]

(iii) State the name of the structure in cells that contains the genetic material.

..... [1]

[Total: 8]

- 5 (a) A student investigates the rate of reaction between calcium carbonate and hydrochloric acid.

The student does the experiment four times and each time uses:

- the same mass of calcium carbonate
- different sizes of calcium carbonate pieces
- a different concentration of hydrochloric acid.

Table 5.1 shows the four experiments, **A**, **B**, **C** and **D**.

Table 5.1

experiment	size of calcium carbonate pieces	concentration of hydrochloric acid
A	large	dilute
B	large	concentrated
C	small	dilute
D	small	concentrated

- (i) State which experiment has the fastest rate of reaction.

experiment [1]

- (ii) The student measures the rate of reaction by timing how long it takes for the calcium carbonate pieces to disappear.

Suggest the piece of apparatus the student uses to measure a time of 100s.

..... [1]

- (b) The student wants to determine the pH of the acid. She puts some universal indicator paper into the acid.

- (i) Describe how the student uses the colour of the universal indicator paper to determine the pH of the hydrochloric acid and its relative acidity.

.....

 [2]

- (ii) Suggest the pH of dilute hydrochloric acid.

pH = [1]

(c) Hydrogen chloride, HCl , dissolves in water to make hydrochloric acid.

(i) Complete the dot-and-cross diagram in Fig. 5.1 to show the bonding in a molecule of hydrogen chloride.

Only show the outer shell electrons.

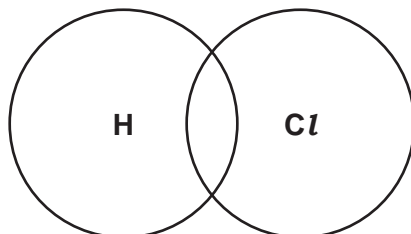

Fig. 5.1

[2]

(ii) State the name of this type of chemical bonding.

..... [1]

(d) Hydrogen chloride is a gas. Water is a liquid.

Describe the difference in the structure between a liquid and a gas, in terms of particle separation and the motion of the particles.

particle separation

.....

motion

.....

[2]

[Total: 10]

- 6 (a) Fig. 6.1 shows how the energy transfers in a television when 100J of electrical energy are supplied.

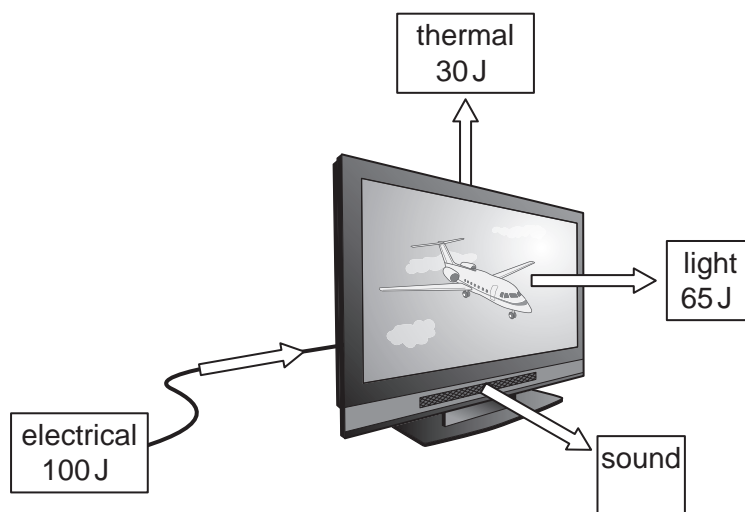

Fig. 6.1

- (i) Calculate the energy transferred as sound.

energy = J [1]

- (ii) Complete the sentences using the energy transfers shown in Fig. 6.1.

The television is designed to transfer energy
 to energy and energy.
 energy is wasted by the television.

[3]

- (iii) The weight of the television is 120N.

Calculate the mass of the television.

The gravitational force on unit mass, g , is 10N/kg.

mass = kg [2]

(b) Fig. 6.2 shows the power socket which supplies electricity to a television, a laptop and a printer.

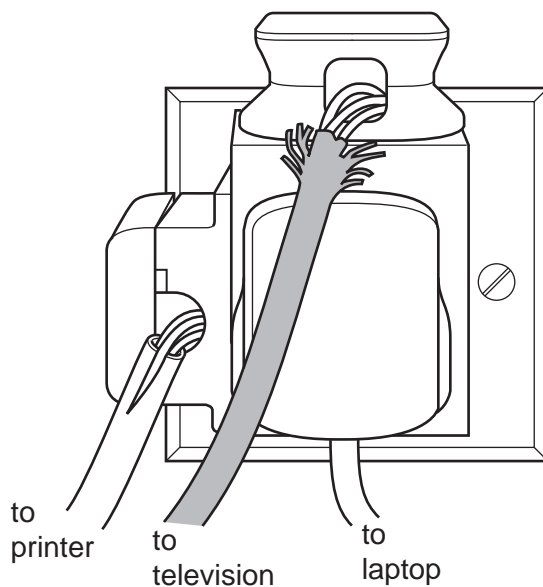

Fig. 6.2

(i) State the electrical hazard visible on Fig. 6.2.

.....
..... [1]

(ii) Explain why the hazard identified in (b)(i) is **not** safe.

.....
.....
..... [1]

(c) A ray of light from the television is reflected by a mirror.

This is shown in Fig. 6.3.

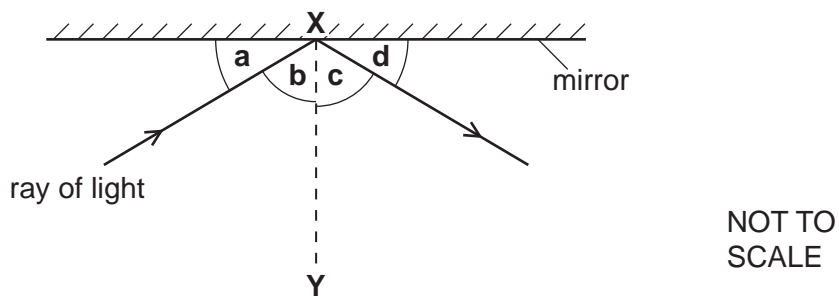

Fig. 6.3

(i) State the name of the line **XY**.

..... [1]

(ii) State which angle, **a**, **b**, **c** or **d**, is the angle of incidence.

..... [1]

(iii) State the relationship between the angle of incidence and the angle of reflection.

..... [1]

[Total: 11]

BLANK PAGE

7 (a) Fig. 7.1 is a diagram of the alimentary canal and associated organs.

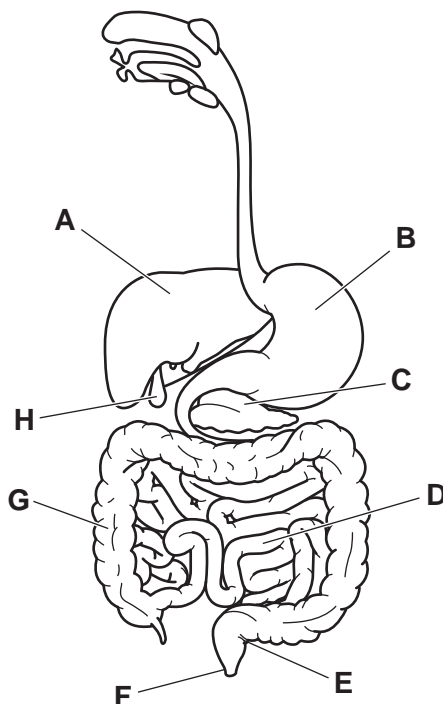

Fig. 7.1

(i) Identify the letter in Fig. 7.1 that represents the part:

where egestion occurs

where most absorption of food molecules occurs

that releases food into the small intestine

[3]

(ii) State the names of parts **A** and **C** in Fig. 7.1.

A

C

[2]

(b) **Circle** the correct words in bold in the sentence to describe assimilation.

Assimilation is the movement of **digested/insoluble** food molecules into the **cells/genes** of the body where they are used.

[1]

(c) (i) The boxes on the left show principal sources of some nutrients.

The boxes on the right show the names of some nutrients.

Draw lines to link each principal source with the main nutrient it supplies.

butter	carbohydrate
rice	fat
tuna fish	protein
	vitamin C

[3]

(ii) List the chemical elements that make up carbohydrates.

..... [1]

(iii) Describe the importance of calcium in the diet.

.....
..... [1]

[Total: 11]

8 (a) Aluminium is obtained from its ore. Aluminium ore is a finite resource, so conserving aluminium is important.

(i) Explain what is meant by the term finite resource.

.....
..... [1]

(ii) State the name of the ore from which aluminium is extracted.

..... [1]

(b) Aluminium is a metal.

State **two** physical or chemical properties of aluminium that make it suitable for use as food containers.

Explain your answers.

1
explanation
2
explanation
..... [3]

(c) (i) Aluminium is often used in alloys.

State the meaning of the term alloy.

.....
..... [1]

- (ii) Table 8.1 shows the composition of elements by mass of 100g of an aluminium alloy.

Table 8.1

element	mass/g
aluminium	
copper	1.3
iron	0.6
magnesium	1.1
nickel	2.3
silicon	10.9

Calculate the mass of aluminium in 100g of the alloy.

mass of aluminium =g [1]

- (iii) Identify the **three** transition elements listed in Table 8.1.

1

2

3

[2]

[Total: 9]

- 9 (a) Table 9.1 shows the highest and lowest frequencies that five animals can hear.

Table 9.1

animal	highest frequency/Hz	lowest frequency/Hz
bat	200 000	2000
dog	50 000	50
dolphin	130 000	1000
elephant	12 000	5
rat	76 000	200

- (i) State which animals from Table 9.1 can hear sounds with a pitch higher than a rat can hear.

Explain your answer.

.....
 [2]

- (ii) A bat emits a high frequency sound.

State the range of frequencies emitted by a bat that a healthy human ear can hear.

highest frequency Hz

lowest frequency Hz

[2]

- (b) (i) A bat flies at a constant speed of 40 m/s.

Calculate the time taken by the bat to travel 200 m.

time = s [2]

- (ii) Bats and birds often fly into wind turbines and are killed.

State **one** other disadvantage of using wind turbines to generate electrical energy.

.....
 [1]

- (iii) Wind energy is an example of a renewable energy source.

State **one** other renewable energy source.

..... [1]

- (c) (i) Some bats are able to detect ultraviolet radiation. Ultraviolet radiation is part of the electromagnetic spectrum.

Fig. 9.1 shows an incomplete electromagnetic spectrum.

Write ultraviolet in the correct position in the electromagnetic spectrum.

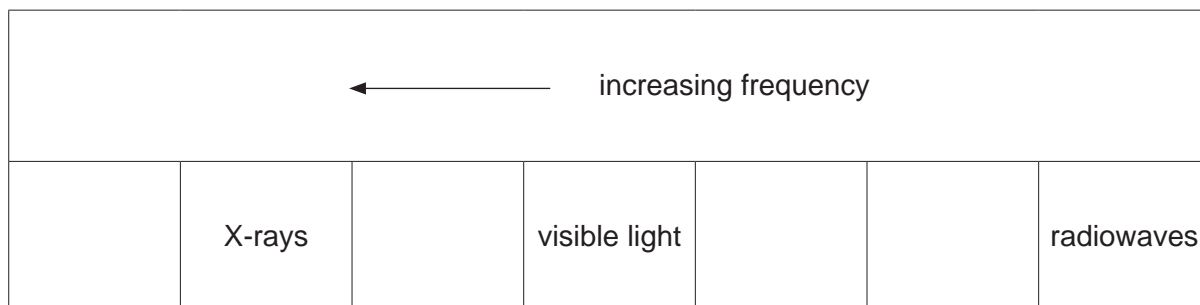

Fig. 9.1

[1]

- (ii) State **one** danger of ultraviolet radiation to humans.

..... [1]

[Total: 10]

10 (a) Fig. 10.1 is a diagram of the gas exchange system in humans.

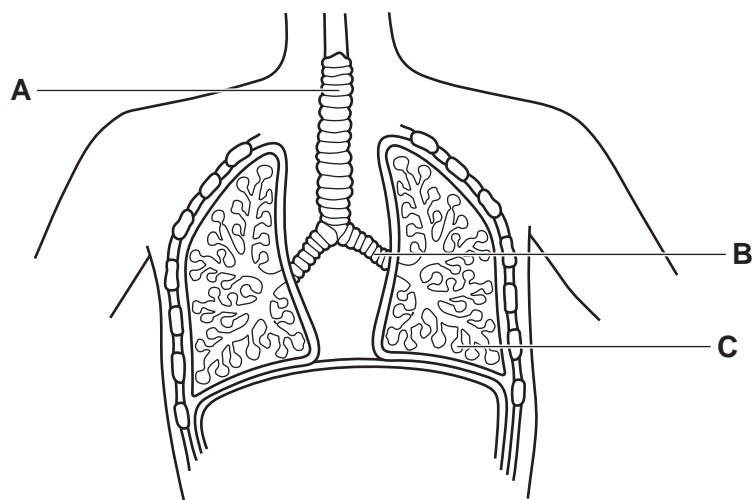

Fig. 10.1

State the names of the parts labelled **A**, **B** and **C** in Fig. 10.1.

A

B

C

[3]

(b) Describe **three** ways the composition of expired air is different from inspired air.

1

.....

2

.....

3

.....

[3]

(c) Gases move across the gas exchange surface by diffusion.

Place ticks (✓) next to **all** the statements that correctly describe diffusion.

Diffusion is due to the random movement of particles.	
Diffusion is the movement of only water molecules.	
Diffusion occurs across a cell membrane.	
Diffusion requires energy from aerobic respiration.	
Diffusion occurs against a concentration gradient.	

[2]

(d) Gas exchange also occurs in plants.

(i) State the name of the part of the leaf where water vapour exits.

..... [1]

(ii) State the term used to describe when water evaporates and then diffuses out of a leaf.

..... [1]

(iii) State **two** factors that **increase** the rate of water loss from a leaf.

1

2

[2]

[Total: 12]

11 (a) Methane, CH₄, is the main constituent of a fossil fuel.

(i) State the name of this fossil fuel.

..... [1]

(ii) State the name of **one** other fossil fuel.

..... [1]

(iii) Methane is a greenhouse gas.

State the name of **one** other common greenhouse gas.

..... [1]

(b) Complete Fig. 11.1 to show the structural formula of methane.

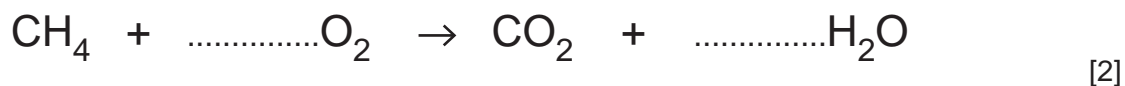

Fig. 11.1

[1]

(c) (i) When methane is completely combusted in oxygen, carbon dioxide and water are produced.

Balance the symbol equation for this reaction.



(ii) The combustion of methane is an exothermic reaction.

Describe what is observed during an exothermic reaction.

.....
 [1]

(d) (i) State which diagram from Fig. 11.2 shows the structural formula of an alcohol.

A

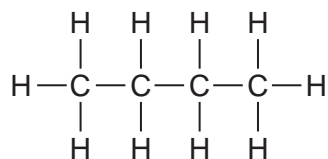

B

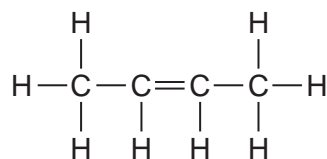

C

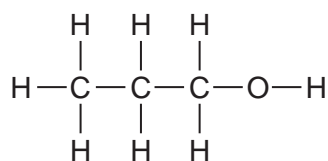

D

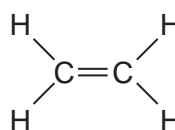

Fig. 11.2

..... [1]

(ii) Describe the chemical test that distinguishes between **A** and **B** in Fig. 11.2.

test

result for **A**

.....

result for **B**

.....

[3]

[Total: 11]

12 Fig. 12.1 shows a refrigerator.

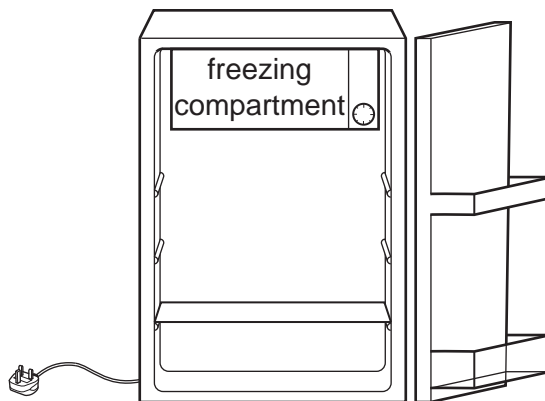



Fig. 12.1

(a) (i) The refrigerator uses electrical energy to:

- power the electric motor which operates the cooler
- light the lamp inside the refrigerator.

The electric motor and the lamp are connected in parallel.

The circuit symbol for a motor is 

Complete the circuit diagram for the refrigerator shown in Fig. 12.2.

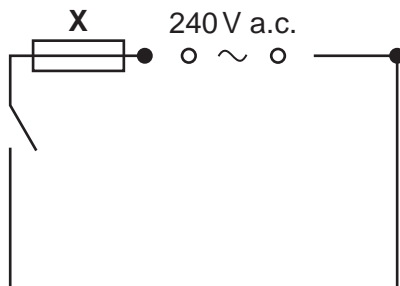

Fig. 12.2

[2]

(ii) State the name of component X.

..... [1]

(iii) State the purpose of component X in this circuit.

.....
 [1]

(b) Food is kept in a refrigerator so that it stays fresh for longer.

Another way to preserve food is to treat it with γ -radiation.

γ -radiation is a form of ionising radiation.

State the name of **one** other form of ionising radiation.

..... [1]

(c) The volume of air in the refrigerator is 0.25 m^3 .

The density of the air is 1.28 kg/m^3 .

Calculate the mass of the air in the refrigerator in grams.

mass = g [3]

(d) Fig. 12.3 shows a liquid-in-glass thermometer.



Fig. 12.3

The thermometer is used to measure the temperature inside the freezing compartment of the refrigerator. This temperature is $-18\text{ }^{\circ}\text{C}$.

Table 12.1 gives some information about four liquids.

Table 12.1

liquid	melting point/ $^{\circ}\text{C}$	boiling point/ $^{\circ}\text{C}$
ethanol	-114	$+78$
mercury	-39	$+367$
methanol	-98	$+65$
water	0	$+100$

(i) Identify all the liquids from Table 12.1 that are suitable for use in this thermometer.

..... [1]

(ii) State the physical property of the liquid in the thermometer that varies with temperature.

..... [1]

[Total: 10]

BLANK PAGE

Permission to reproduce items where third-party owned material protected by copyright is included has been sought and cleared where possible. Every reasonable effort has been made by the publisher (UCLES) to trace copyright holders, but if any items requiring clearance have unwittingly been included, the publisher will be pleased to make amends at the earliest possible opportunity.

To avoid the issue of disclosure of answer-related information to candidates, all copyright acknowledgements are reproduced online in the Cambridge Assessment International Education Copyright Acknowledgements Booklet. This is produced for each series of examinations and is freely available to download at www.cambridgeinternational.org after the live examination series.

Cambridge Assessment International Education is part of Cambridge Assessment. Cambridge Assessment is the brand name of the University of Cambridge Local Examinations Syndicate (UCLES), which is a department of the University of Cambridge.

The Periodic Table of Elements

Group																		
I	II		III										IV	V	VI	VII	VIII	
3 Li lithium 7	4 Be beryllium 9	Key atomic number atomic symbol name relative atomic mass																2 He helium 4
11 Na sodium 23	12 Mg magnesium 24																	1 H hydrogen 1
19 K potassium 39	20 Ca calcium 40	21 Sc scandium 45	22 Ti titanium 48	23 V vanadium 51	24 Cr chromium 52	25 Mn manganese 55	26 Fe iron 56	27 Co cobalt 59	28 Ni nickel 59	29 Cu copper 64	30 Zn zinc 65	31 Ga gallium 70	32 Ge germanium 73	33 As arsenic 75	34 Se selenium 79	35 Br bromine 80	36 Kr krypton 84	
37 Rb rubidium 85	38 Sr strontium 88	39 Y yttrium 89	40 Zr zirconium 91	41 Nb niobium 93	42 Mo molybdenum 96	43 Tc technetium —	44 Ru ruthenium 101	45 Rh rhodium 103	46 Pd palladium 106	47 Ag silver 108	48 Cd cadmium 112	49 In indium 115	50 Sn tin 119	51 Sb antimony 122	52 Te tellurium 128	53 I iodine 127	54 Xe xenon 131	
55 Cs caesium 133	56 Ba barium 137	57–71 lanthanoids	72 Hf hafnium 178	73 Ta tantalum 181	74 W tungsten 184	75 Re rhenium 186	76 Os osmium 190	77 Ir iridium 192	78 Pt platinum 195	79 Au gold 197	80 Hg mercury 201	81 Tl thallium 204	82 Pb lead 207	83 Bi bismuth 209	84 Po polonium —	85 At astatine —	86 Rn radon —	
87 Fr francium —	88 Ra radium —	89–103 actinoids	104 Rf rutherfordium —	105 Db dubnium —	106 Sg seaborgium —	107 Bh bohrium —	108 Hs hassium —	109 Mt meitnerium —	110 Ds darmstadtium —	111 Rg roentgenium —	112 Cn copernicium —	114 Fl flerovium —	116 Lv livermorium —	—	—	—	—	

57 La lanthanum 139	58 Ce cerium 140	59 Pr praseodymium 141	60 Nd neodymium 144	61 Pm promethium —	62 Sm samarium 150	63 Eu europium 152	64 Gd gadolinium 157	65 Tb terbium 159	66 Dy dysprosium 163	67 Ho holmium 165	68 Er erbium 167	69 Tm thulium 169	70 Yb ytterbium 173	71 Lu lutetium 175
89 Ac actinium —	90 Th thorium 232	91 Pa protactinium 231	92 U uranium 238	93 Np neptunium —	94 Pu plutonium —	95 Am americium —	96 Cm curium —	97 Bk berkelium —	98 Cf californium —	99 Es einsteinium —	100 Fm fermium —	101 Md mendelevium —	102 No nobelium —	103 Lr lawrencium —

The volume of one mole of any gas is 24 dm^3 at room temperature and pressure (r.t.p.).