



Cambridge Assessment International Education
Cambridge International General Certificate of Secondary Education

CANDIDATE
NAME

CENTRE
NUMBER

--	--	--	--	--	--

CANDIDATE
NUMBER

--	--	--	--	--



CO-ORDINATED SCIENCES

0654/32

Paper 3 Theory (Core)

May/June 2019

2 hours

Candidates answer on the Question Paper.

No Additional Materials are required.

READ THESE INSTRUCTIONS FIRST

Write your centre number, candidate number and name on all the work you hand in.

Write in dark blue or black pen.

You may use an HB pencil for any diagrams or graphs.

Do not use staples, paper clips, glue or correction fluid.

DO NOT WRITE IN ANY BARCODES.

Answer **all** questions.

Electronic calculators may be used.

You may lose marks if you do not show your working or if you do not use appropriate units.

A copy of the Periodic Table is printed on page 36.

At the end of the examination, fasten all your work securely together.

The number of marks is given in brackets [] at the end of each question or part question.

This document consists of **30** printed pages and **6** blank pages.

1 (a) Fig. 1.1 is a diagram of an animal cell.

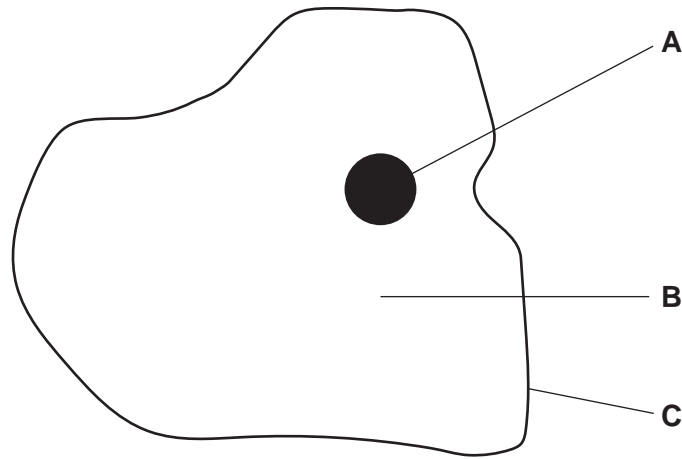

Fig. 1.1

Table 1.1 shows the parts labelled in Fig. 1.1.

Use Fig. 1.1 to complete Table 1.1.

Table 1.1

name of part	letter in Fig. 1.1	function
		controls what enters and leaves the cell
	B	
		contains genetic material

[3]

(b) Animal cells **cannot** photosynthesise.

Describe the function of photosynthesis, **and** state why animal cells are unable to photosynthesise.

.....

.....

..... [2]

(c) Respiration occurs in living cells. Water is a product of respiration.

(i) Name **one other** product of respiration.

..... [1]

(ii) Describe how water moves out of animal cells.

Include the name of the process in your answer.

.....
.....
.....
..... [3]

[Total: 9]

2 Fig. 2.1 shows the chemical symbols of five elements in Period 4 of the Periodic Table.

A copy of the whole Periodic Table is on page 36.

19	20	21	22	23	24	25	26	27	28	29	30	31	32	33	34	35	36
K						Mn		Co								Br	Kr

Fig. 2.1

(a) (i) Explain what the numbers 19 to 36 represent for the elements in Period 4 from K to Kr.

.....
 [1]

(ii) Using only the symbols shown in Fig. 2.1, identify:

- a metallic element
- a non-metallic element
- a transition metal
- a halogen
- the least reactive element in the period
- an element that reacts violently with water.

[3]

(b) An atom of phosphorus contains 15 electrons.

Complete Fig. 2.2 to show the number of electrons in each shell of a phosphorus atom.

One electron in each shell has been drawn for you.

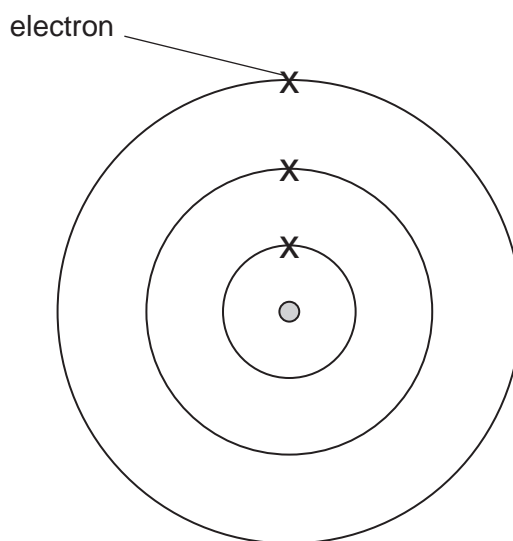

Fig. 2.2

[2]

(c) The elements hydrogen and oxygen combine to form water, H_2O .

Fig. 2.3 shows molecules in a mixture of hydrogen and oxygen.

Fig. 2.4 shows molecules in water vapour.

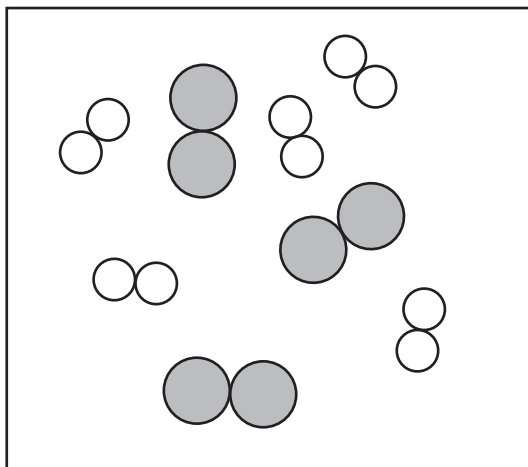

Fig. 2.3

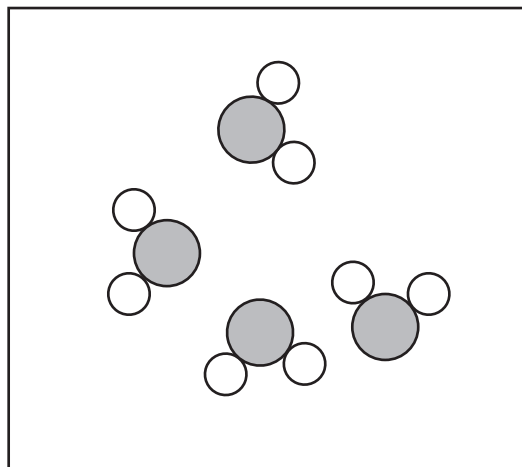

Fig. 2.4

(i) State the formula of an oxygen molecule.

.....

[1]

(ii) Use Fig. 2.3 and Fig. 2.4 to describe **one** difference between a mixture of two elements and a compound of two elements.

.....

..... [2]

[Total: 9]

- 3 (a) Fig. 3.1 shows four different parts of a cyclist's journey.

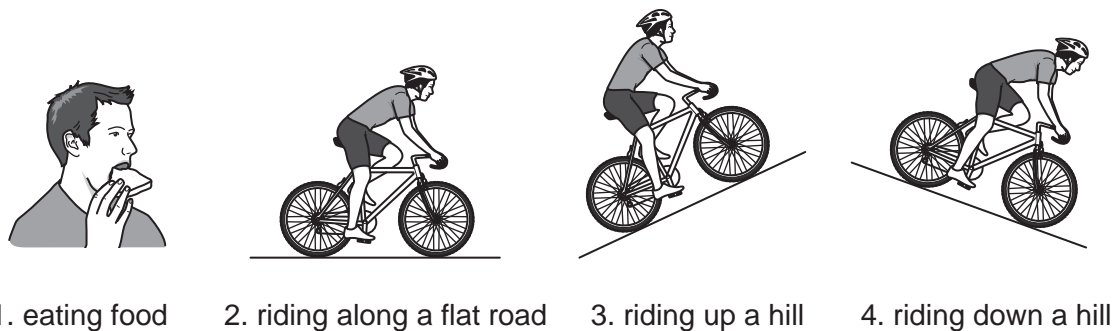

Fig. 3.1

Complete the sentences about **useful** energy transformations using words or phrases from the list. You may use each word or phrase once, more than once or not at all.

chemical potential gravitational potential kinetic sound thermal

The cyclist starts his day by eating food. This provides a store of energy within the cyclist's body.

This energy in the cyclist's body is transferred to energy as the cyclist rides along the flat road.

The cyclist rides up a hill and some of the energy is transferred to energy.

When the cyclist rides down a hill he does not need to pedal. The cyclist gains speed as the energy is transferred to kinetic energy.

[3]

- (b) The cyclist rides the bicycle for a total of 0.5 hours and then stops. The journey was 12 km.

Calculate the average speed of the cyclist.

Show your working.

average speed = km/h [2]

(c) Fig. 3.2 shows the speed-time graph for part of the cyclist's journey.

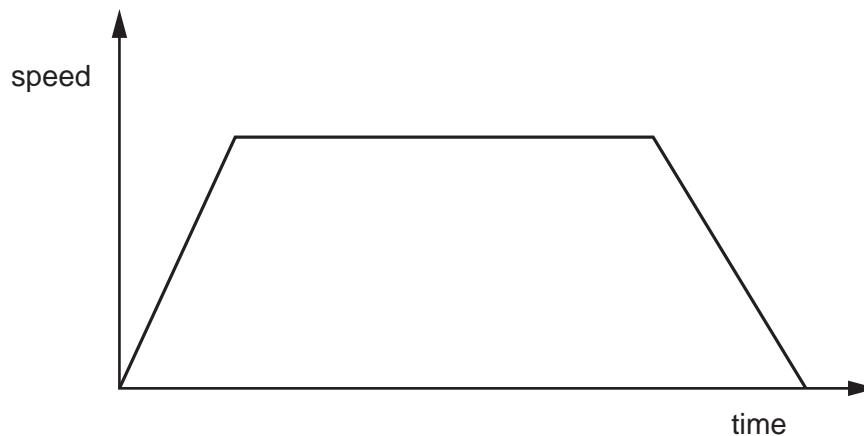

Fig. 3.2

- (i) Label with an **X** a point where the cyclist is at rest. [1]
- (ii) Label with a **Y** a point where the cyclist is moving with changing speed. [1]
- (iii) Label with a **Z** a point where the cyclist is moving with constant speed. [1]

(d) The cyclist uses a bicycle light.

The bicycle light circuit contains a cell, a switch and a lamp.

- (i) Draw a circuit diagram for the bicycle light.

[2]

8

(ii) The potential difference across the lamp is 1.5V.

The current flowing in the circuit is 0.75A.

Calculate the resistance of the lamp.

Show your working.

resistance = Ω [2]

[Total: 12]

- 4 (a) Table 4.1 shows the types and number of teeth in an adult human.

Table 4.1

type of tooth	number of tooth type in adults
canine	4
incisor	8
molar	12
pre-molar	8

- (i) Calculate the total number of teeth in this adult human.

..... [1]

- (ii) Use your answer in (a)(i) to calculate the percentage of human teeth which are **incisors**.
Show your working.

..... % [1]

- (iii) Suggest why herbivores such as sheep have a larger percentage of molars than humans.
Explain your answer.

.....
.....
..... [2]

- (b) There are two types of digestion.

State the type of digestion that involves teeth.

..... [1]

- (c) Describe **two** ways to take proper care of teeth.

1

.....

2

.....

[2]

[Total: 7]

5 (a) The substances calcium, calcium carbonate and calcium oxide react separately with dilute hydrochloric acid.

(i) The same salt is produced when the three substances named above react with dilute hydrochloric acid.

Name this salt.

..... [1]

(ii) Name the gases made when each of the three substances react separately with dilute hydrochloric acid. If no gas is made, write 'no gas'.

calcium

calcium carbonate

calcium oxide

[2]

(b) Calcium oxide is an ionic compound.

Calcium atoms lose electrons to become calcium ions.

State whether a calcium ion has a positive or a negative electrical charge.

Explain your answer.

charge

explanation

.....

.....

[2]

(c) Fig. 5.1 shows a lime kiln.

In a lime kiln, calcium oxide, CaO, is obtained by heating calcium carbonate (limestone), CaCO₃. The reaction also produces carbon dioxide.

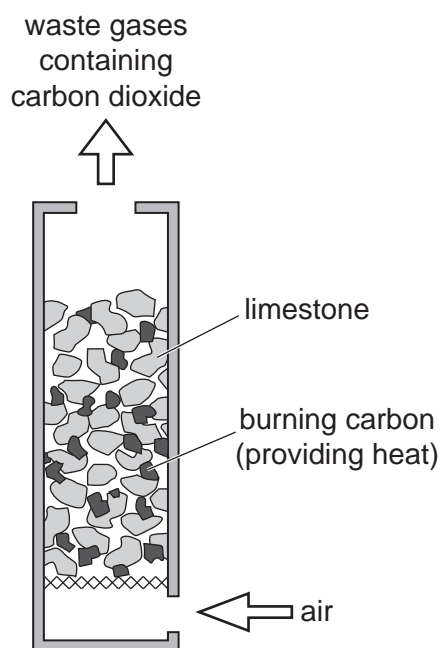

Fig. 5.1

(i) The conversion of calcium carbonate to calcium oxide involves an endothermic chemical reaction.

State the meaning of the term *endothermic*.

.....
 [1]

(ii) Calcium oxide and carbon dioxide are simpler substances than calcium carbonate.

State the type of chemical reaction that converts calcium carbonate to calcium oxide in the lime kiln.

..... [1]

(iii) Construct the word equation for the reaction.

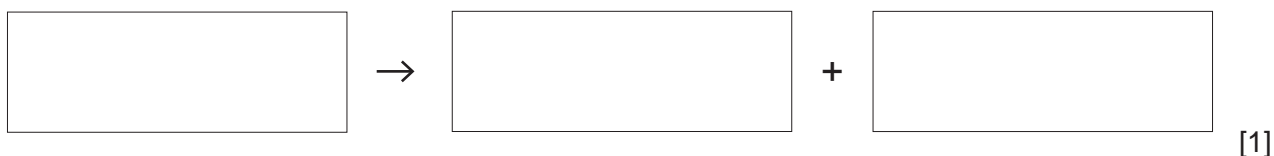

(iv) Suggest why the mixture of waste gases leaving the lime kiln contains a large amount of nitrogen.

.....
 [1]

12

(d) Some industrial waste products are treated with limestone.

Explain why this is done.

.....

.....

..... [2]

[Total: 11]

BLANK PAGE

- 6 (a) Fig. 6.1 shows a presenter talking into a microphone at a radio station, and a man listening to the radio show on a radio at home.

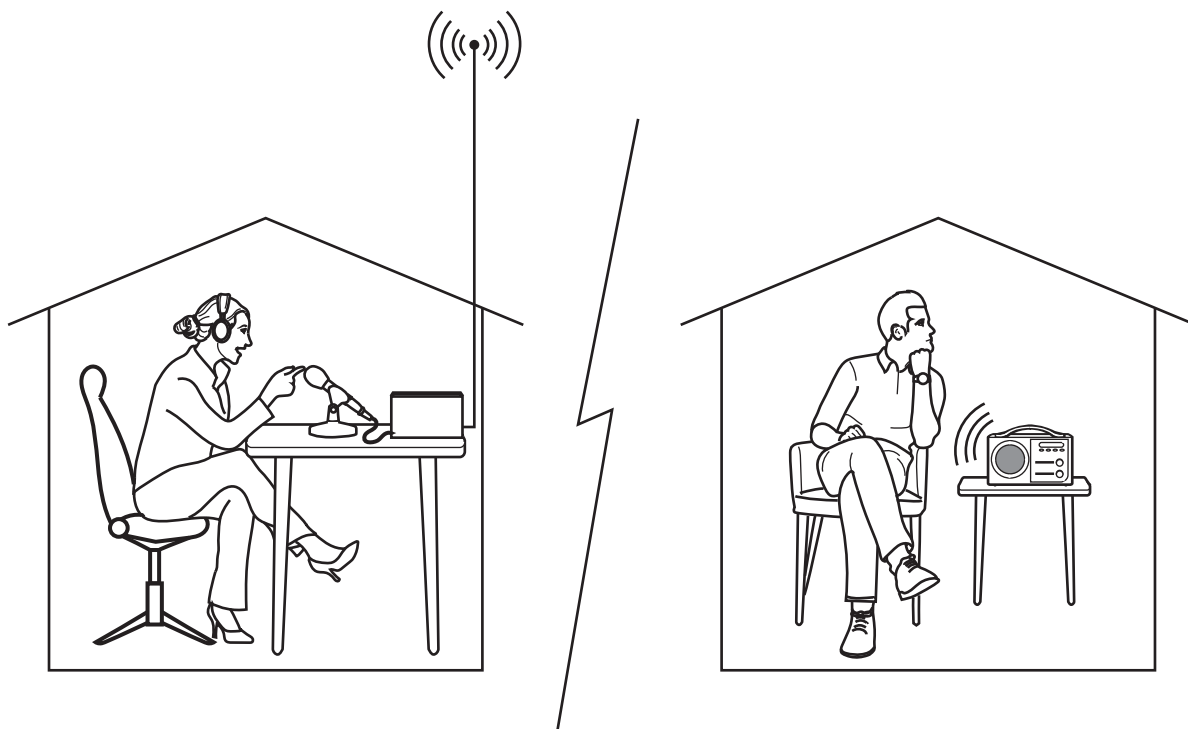

Fig. 6.1

- (i) Write **radio waves** in the correct location in the incomplete electromagnetic spectrum in Fig. 6.2.

gamma rays		ultraviolet	visible			
------------	--	-------------	---------	--	--	--

[1]

Fig. 6.2

- (ii) Fig. 6.3 shows soundwaves travelling in compressions (C) and rarefactions (R) from the loudspeaker to the ear of the man.

On Fig. 6.3 use a double headed arrow (\longleftrightarrow) to show one wavelength.



Fig. 6.3

[1]

- (iii) The distance from the radio station to the man is 500 km.

Suggest why the radio signal arrives at the man's radio almost instantly.

..... [1]

(b) The radio presenter is talking about photography.

(i) Complete the ray diagram in Fig. 6.4 to show how light rays from an object travel through a converging lens and are focused on the image sensor.

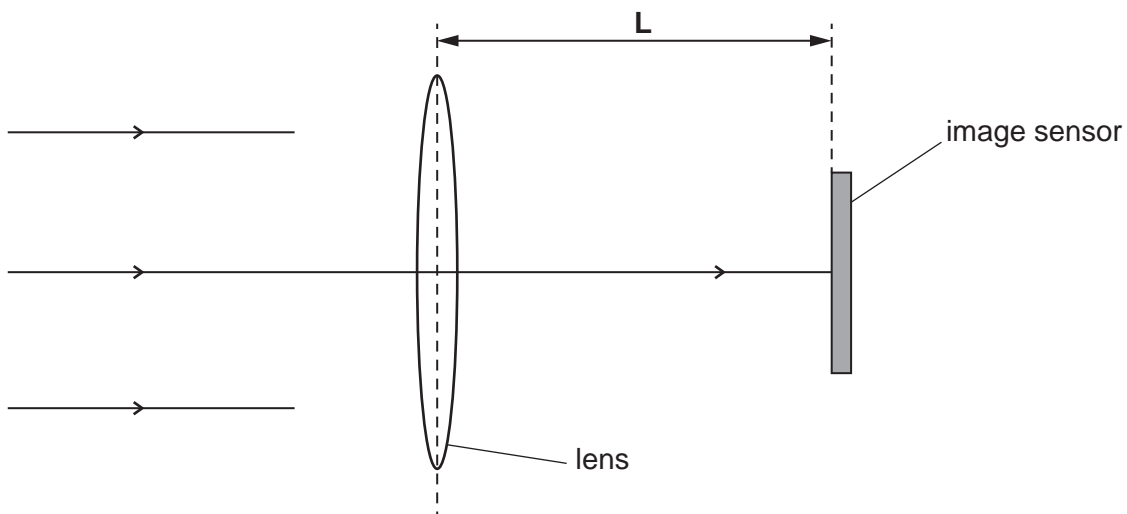

[2]

Fig. 6.4

(ii) State the name of the distance **L** shown in Fig. 6.4.

..... [1]

(c) The man investigates the properties of water.

(i) State the melting point of water.

temperature = °C [1]

(ii) The man boils the water in a kettle to produce steam.

Fig. 6.5 shows different arrangements of molecules in solids, liquids and gases.

Label each of the diagrams using the words **ice**, **steam** and **water** to show the correct arrangement of molecules for each.

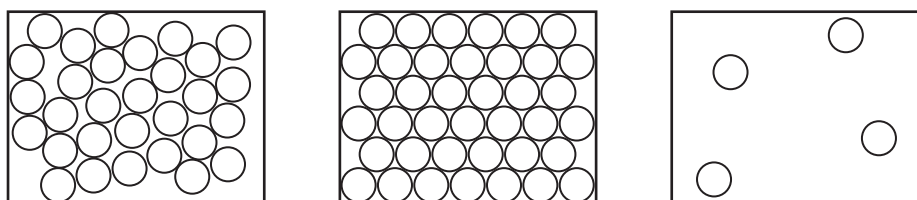

.....

[2]

Fig. 6.5

[Total: 9]

7 (a) Complete the definition of the term *transpiration* using words or phrases from the list.

You may use each word or phrase once, more than once or not at all.

- condensation**
- chlorophyll**
- diffusion**
- evaporation**
- mesophyll**
- osmosis**
- phloem**
- root hair**

Transpiration is the loss of water vapour from plant leaves by
 of water at the surfaces of the cells followed by
 of water vapour through the stomata.

[3]

(b) The graph in Fig. 7.1 shows the effect of humidity on the rate of transpiration.

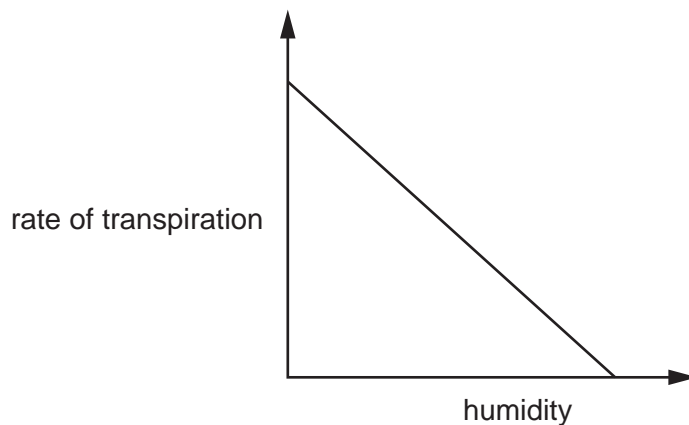

Fig. 7.1

Describe the relationship between humidity and transpiration.

.....

[1]

(c) Complete the graph in Fig. 7.2 to show the effect of temperature on the rate of transpiration.

Include on your graph:

- labels on both axes
- a sketch of a suitable line.



[2]

Fig. 7.2

(d) Name the vessel in plants that transports water from the roots to the leaves.

..... [1]

[Total: 7]

8 Electrolysis is a process which uses electricity to break down a compound.

(a) Complete the sentences using words or phrases from the list.

Each word or phrase may be used once, more than once or not at all.

anode

cathode

cell

electrolyte

gases

insulator

ions

molecules

In electrolysis the liquid is called the because it contains that are free to move.

The positive electrode is called the and the negative electrode is called the

[3]

(b) A student uses the apparatus shown in Fig. 8.1 to investigate the electrolysis of dilute sulfuric acid.

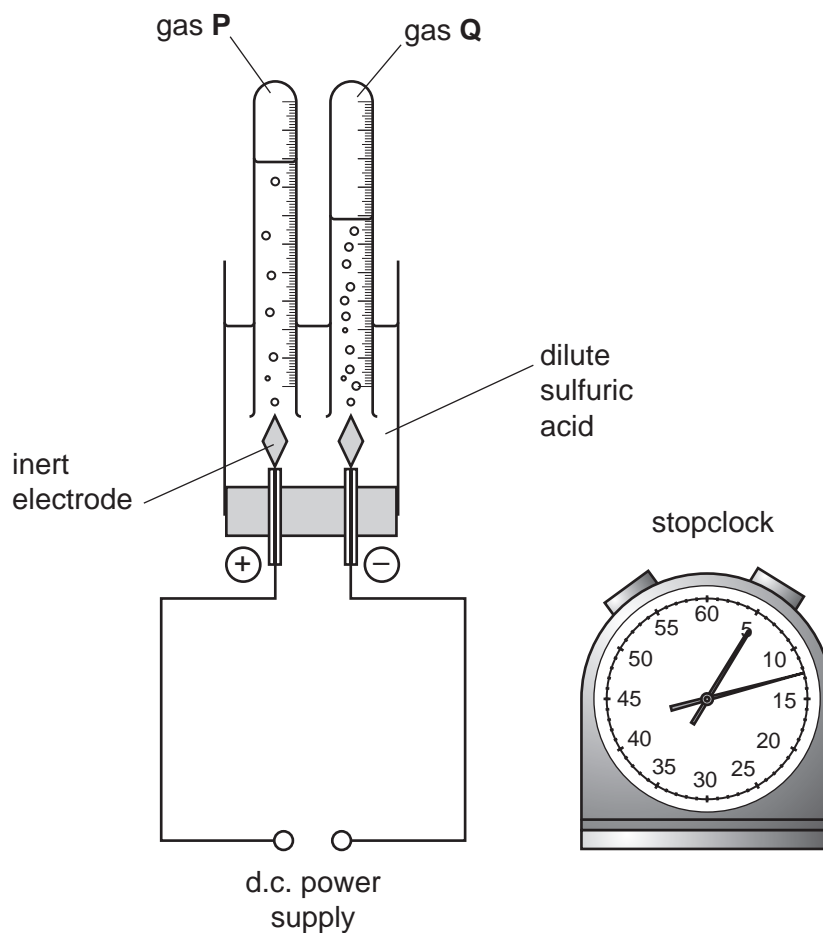

Fig. 8.1

The student turns on the power supply and starts the stopclock.

She records the volume of gas **P** and the volume of gas **Q** every minute for 20 minutes.

Her results are shown in Fig. 8.2.

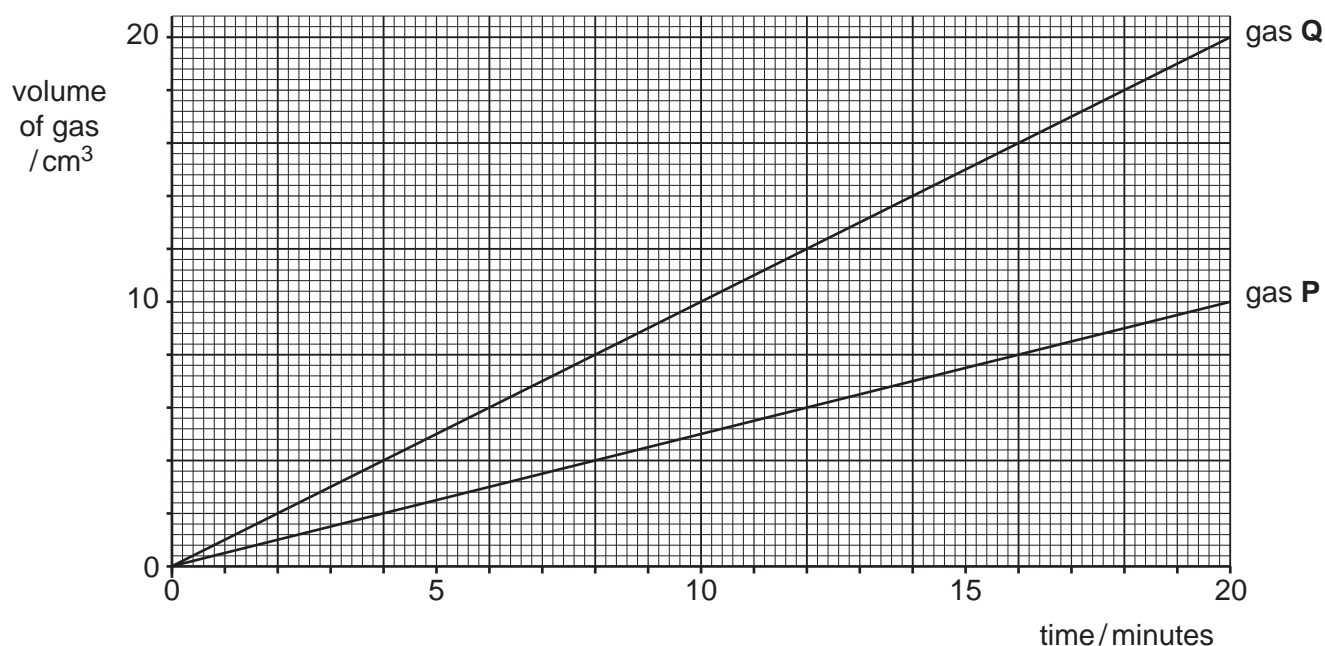

Fig. 8.2

- (i) Gas **P** forms at the positive electrode and gas **Q** forms at the negative electrode.

Identify the gases.

gas **P**

gas **Q**

[2]

- (ii) Using the graph, state the total volume of gas **P** produced during the investigation.

volume of gas **P** = cm³ [1]

- (iii) Use the information in Fig. 8.2 to compare quantitatively the rates of production of gas **P** and gas **Q**.

.....

..... [1]

- (iv) Use the information in Fig. 8.2 to calculate the rate at which gas **P** is produced in units of cm³/minute.

Show your working.

rate of production of gas **P** = cm³/minute [1]

20

(c) Metal **M** is extracted from the ore bauxite by electrolysis.

Metal **M** is used to make many useful products.

(i) Name metal **M**.

..... [1]

(ii) Bauxite is a finite resource.

State **one** way that the need for bauxite can be reduced.

.....

..... [1]

[Total: 10]

BLANK PAGE

9 Petroleum is a non-renewable energy resource used to produce electricity.

(a) Place a tick (✓) in the boxes to correctly describe each energy resource as either renewable or non-renewable.

energy resource	renewable	non-renewable
coal		
geothermal		
natural gas		
solar		
waves		

[2]

(b) State **two** disadvantages of energy production using wind turbines.

1

2

[2]

(c) Fig. 9.1 shows supply cables from a power station supported by pylons.

The cables are suspended loosely in hot weather.

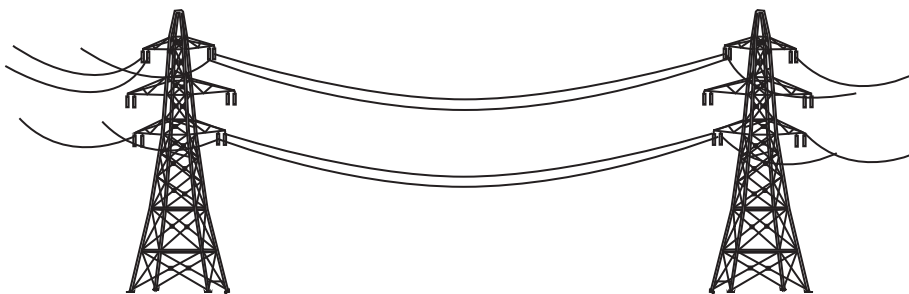

Fig. 9.1

Explain why the cables must be suspended loosely in hot weather.

.....

 [2]

- (d) Fig. 9.2 shows a saucepan of water being heated on an electric cooker. The water is heated to boiling point and continues to boil for 30 minutes.

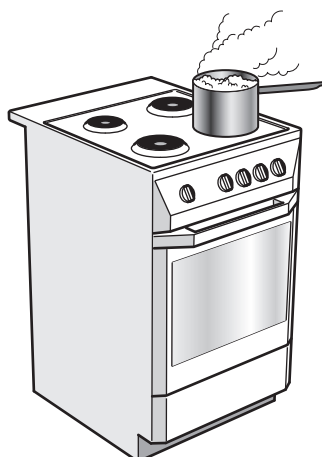

Fig. 9.2

- (i) Describe what happens to the temperature of the water while it is boiling.

..... [1]

- (ii) The cooker is switched off and the water is allowed to cool.

Before heating, the mass of the water in the saucepan was 1000g. The mass of the water in the saucepan is now 600g.

Determine the mass of water that has been lost from the saucepan.

mass of water lost from the saucepan = g [1]

- (iii) State what has happened to the water that has been lost from the saucepan.

..... [1]

[Total: 9]

10 (a) Describe the difference between **phenotypic variation** and **genetic variation**.

.....

.....

.....

..... [2]

(b) A class investigated the number of students that are able to roll their tongues.

Fig. 10.1 is a graph of the results.

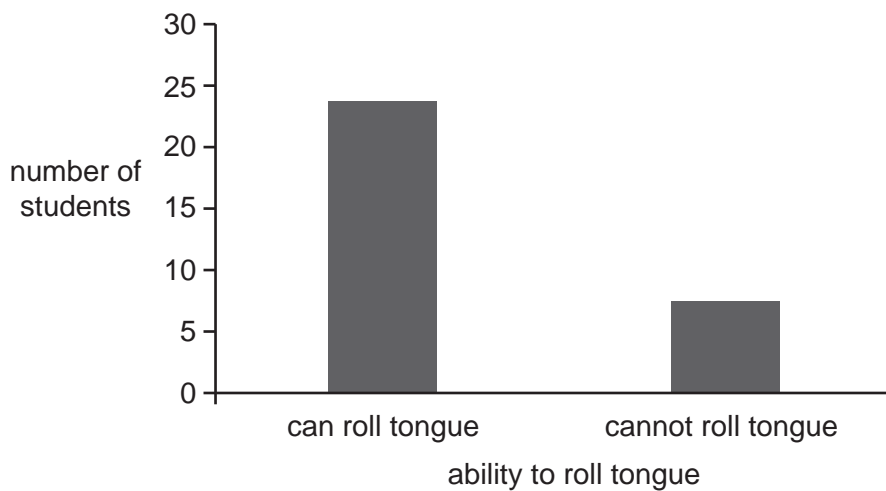

Fig. 10.1

Use evidence from Fig. 10.1 to explain why this is an example of **discontinuous** variation.

.....

..... [1]

(c) The list shows some examples of different types of variation.

Place a tick (✓) in the boxes to show **all** the examples of **continuous** variation.

height	<input type="checkbox"/>
foot length	<input type="checkbox"/>
sex (gender)	<input type="checkbox"/>
types of teeth	<input type="checkbox"/>
mass	<input type="checkbox"/>

[2]

(d) Fig. 10.2 is a photograph of a giraffe, a mammal. Giraffes eat the leaves from branches on trees.



Fig. 10.2

The ancestors of giraffes had shorter necks.

Describe how giraffes developed long necks by natural selection.

Use the words **variation**, **competition** and **alleles** in your answer.

.....

.....

.....

.....

.....

.....

..... [4]

[Total: 9]

- 11 (a) Fig. 11.1 shows a beaker containing sand and aqueous sodium chloride.

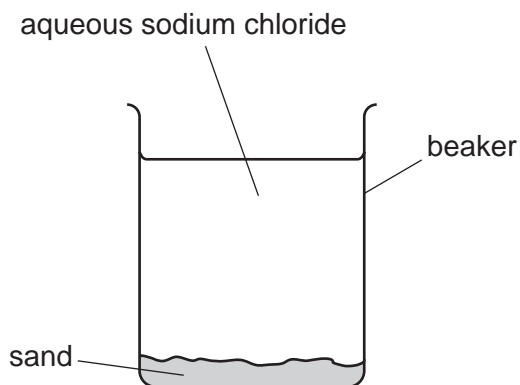

Fig. 11.1

Suggest a method used to separate
the sand from the aqueous sodium chloride

.....
the water from sodium chloride.

.....
[2]

- (b) Fig. 11.2 shows fractional distillation being used to separate ethanol and water.

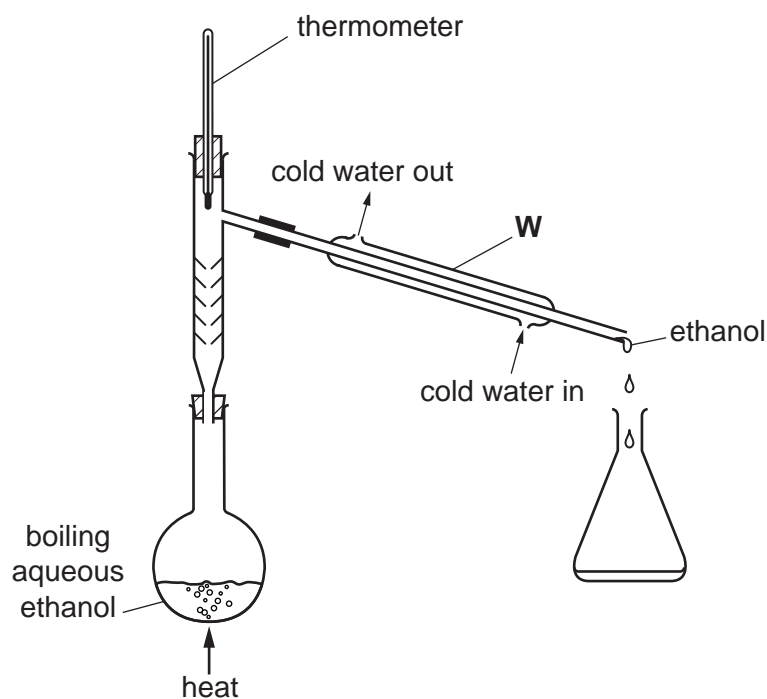

Fig. 11.2

- (i) Suggest the purpose of the part of the apparatus labelled **W**.

.....
 [1]

- (ii) Explain why ethanol can be separated from water by fractional distillation.

.....
 [1]

- (c) Fractional distillation is used in industry to obtain useful hydrocarbons from a raw material **R**.

- (i) Identify raw material **R**.

..... [1]

- (ii) Ethane and ethene are hydrocarbons.

The structure of an ethane molecule is shown below.

Complete the diagram of an ethene molecule.

ethane	ethene
$ \begin{array}{c} \text{H} \quad \text{H} \\ \quad \\ \text{H} - \text{C} - \text{C} - \text{H} \\ \quad \\ \text{H} \quad \text{H} \end{array} $	$ \begin{array}{c} \text{H} \quad \text{H} \\ \quad \\ \text{C} \quad \text{C} \end{array} $

[2]

(d) Alkenes are produced when alkanes are heated in the presence of a catalyst.

Fig. 11.3 shows laboratory apparatus used for this reaction.

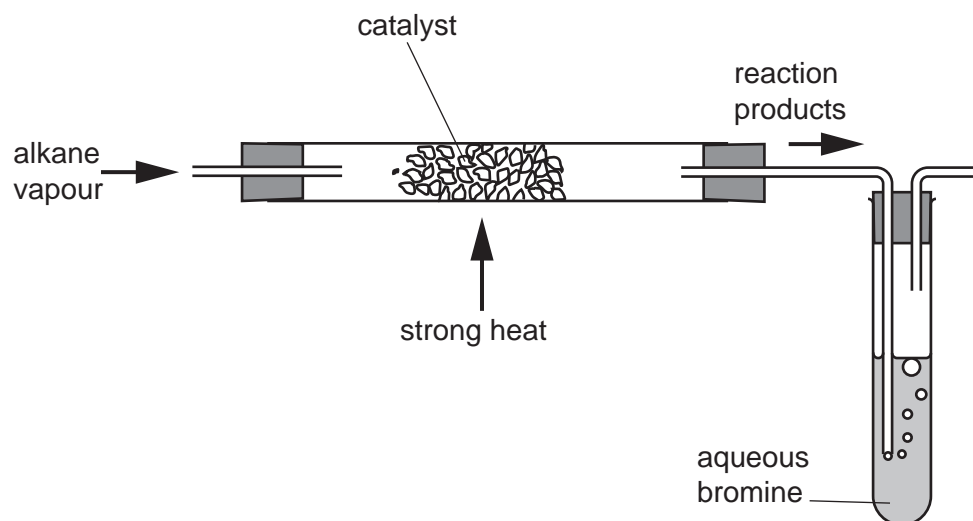

Fig. 11.3

(i) Name the process that converts alkanes into alkenes.

..... [1]

(ii) State the colour change which is observed in the bromine solution during the process.

colour changes from to [2]

[Total: 10]

BLANK PAGE

12 (a) Fig. 12.1 shows a bridge between two supports.

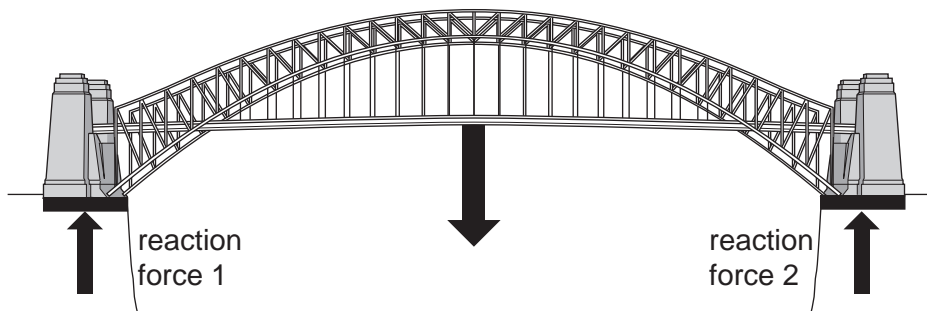

Fig. 12.1

(i) Name the force that is represented by the vertical downwards arrow from the bridge.

..... [1]

(ii) The bridge has a mass of 625 000 kg.

Calculate the downwards force of the bridge.

gravitational field strength = 10 N/kg.

downwards force = N [2]

(iii) The bridge is supported by reaction force 1 and reaction force 2.

Using your answer to (a)(ii) state the total size of the reaction forces (reaction force 1 + reaction force 2).

Explain your answer.

total reaction forces = N

explanation

..... [2]

(b) The bridge is supported on granite rocks. Radioactive radon gas seeps out of the rocks in small quantities.

(i) State **one** danger of ionising radiation to living things.

..... [1]

(ii) A radiation counter produces a clicking sound for each ionising particle detected.

A piece of paper is placed between the rock and the counter and the clicking sounds stop.

State the type of radiation that is being emitted by the rock.

..... [1]

(iii) Radon gas from rocks contributes to background radiation.

Suggest **one** other source of background radiation.

..... [1]

(iv) A sample of granite contains 1 000 000 atoms of radon-222.

Radon-222 has a half life of 3.8 days.

Calculate the number of radon-222 atoms remaining after 7.6 days.

Show your working.

number of atoms remaining [2]

[Total: 10]

13 (a) Fig. 13.1 is a diagram of the male reproductive system.

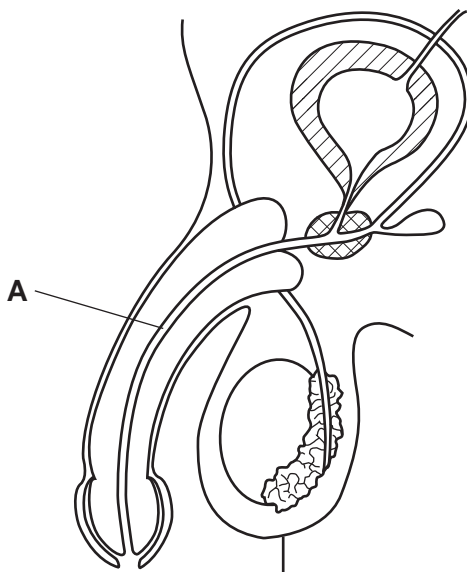

Fig. 13.1

(i) Name **two** liquids carried by the tube labelled **A** in Fig. 13.1.

1

2 [2]

(ii) Sperm swim in a liquid secreted from one part of the male reproductive system shown in Fig. 13.1.

Draw an **X** on Fig. 13.1 to identify this part. [1]

(b) (i) State the term that describes the fusion of nuclei of male and female gametes.

..... [1]

(ii) State the part of the male reproductive system where gametes are produced.

..... [1]

(iii) State the name of the female gamete.

..... [1]

(c) Reproduction is one of the characteristics of living things.

State **two other** characteristics of living things.

1

2 [2]

[Total: 8]

BLANK PAGE

BLANK PAGE

Permission to reproduce items where third-party owned material protected by copyright is included has been sought and cleared where possible. Every reasonable effort has been made by the publisher (UCLES) to trace copyright holders, but if any items requiring clearance have unwittingly been included, the publisher will be pleased to make amends at the earliest possible opportunity.

To avoid the issue of disclosure of answer-related information to candidates, all copyright acknowledgements are reproduced online in the Cambridge Assessment International Education Copyright Acknowledgements Booklet. This is produced for each series of examinations and is freely available to download at www.cambridgeinternational.org after the live examination series.

Cambridge Assessment International Education is part of the Cambridge Assessment Group. Cambridge Assessment is the brand name of the University of Cambridge Local Examinations Syndicate (UCLES), which itself is a department of the University of Cambridge.

The Periodic Table of Elements

		Group															
I	II	III	IV	V	VI	VII	VIII					VIII					
3 Li lithium 7	4 Be beryllium 9	1 H hydrogen 1	5 B boron 11	6 C carbon 12	7 N nitrogen 14	8 O oxygen 16	9 F fluorine 19	10 Ne neon 20					18 Ar argon 40				
11 Na sodium 23	12 Mg magnesium 24	<p>Key</p> <p>atomic number</p> <p>atomic symbol</p> <p>name</p> <p>relative atomic mass</p>										17 Cl chlorine 35.5					
19 K potassium 39	20 Ca calcium 40	21 Sc scandium 45	22 Ti titanium 48	23 V vanadium 51	24 Cr chromium 52	25 Mn manganese 55	26 Fe iron 56	27 Co cobalt 59	28 Ni nickel 59	29 Cu copper 64	30 Zn zinc 65	31 Al aluminium 27	32 Si silicon 28	33 P phosphorus 31	34 S sulfur 32	35 Br bromine 80	36 Kr krypton 84
37 Rb rubidium 85	38 Sr strontium 88	39 Y yttrium 89	40 Zr zirconium 91	41 Nb niobium 93	42 Mo molybdenum 96	43 Tc technetium —	44 Ru ruthenium 101	45 Rh rhodium 103	46 Pd palladium 106	47 Ag silver 108	48 Cd cadmium 112	49 In indium 115	50 Sn tin 119	51 Sb antimony 122	52 Te tellurium 128	53 I iodine 127	54 Xe xenon 131
55 Cs caesium 133	56 Ba barium 137	57–71 lanthanoids	72 Hf hafnium 178	73 Ta tantalum 181	74 W tungsten 184	75 Re rhenium 186	76 Os osmium 190	77 Ir iridium 192	78 Pt platinum 195	79 Au gold 197	80 Hg mercury 201	81 Tl thallium 204	82 Pb lead 207	83 Bi bismuth 209	84 Po polonium —	85 At astatine —	86 Rn radon —
87 Fr francium —	88 Ra radium —	89–103 actinoids	104 Rf rutherfordium —	105 Db dubnium —	106 Sg seaborgium —	107 Bh bohrium —	108 Hs hassium —	109 Mt meitnerium —	110 Ds darmstadtium —	111 Rg roentgenium —	112 Cn copernicium —	114 Fl flerovium —	116 Lv livermorium —	118 Og oganeson —	119 Uu ununium —	120 Uub ununium —	121 Uut ununium —

57 La lanthanum 139	58 Ce cerium 140	59 Pr praseodymium 141	60 Nd neodymium 144	61 Pm promethium —	62 Sm samarium 150	63 Eu europium 152	64 Gd gadolinium 157	65 Tb terbium 159	66 Dy dysprosium 163	67 Ho holmium 165	68 Er erbium 167	69 Tm thulium 169	70 Yb ytterbium 173	71 Lu lutetium 175
89 Ac actinium —	90 Th thorium 232	91 Pa protactinium 231	92 U uranium 238	93 Np neptunium —	94 Pu plutonium —	95 Am americium —	96 Cm curium —	97 Bk berkelium —	98 Cf californium —	99 Es einsteinium —	100 Fm fermium —	101 Md mendelevium —	102 No nobelium —	103 Lr lawrencium —

lanthanoids

actinoids

The volume of one mole of any gas is 24 dm³ at room temperature and pressure (r.t.p.).