



## Cambridge IGCSE™ (9–1)

CANDIDATE  
NAME

CENTRE  
NUMBER

--	--	--	--	--

CANDIDATE  
NUMBER

--	--	--	--

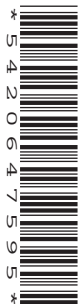

**CO-ORDINATED SCIENCES**

**0973/31**

Paper 3 Theory (Core)

**October/November 2020**

**2 hours**

You must answer on the question paper.

No additional materials are needed.

### INSTRUCTIONS

- Answer **all** questions.
- Use a black or dark blue pen. You may use an HB pencil for any diagrams or graphs.
- Write your name, centre number and candidate number in the boxes at the top of the page.
- Write your answer to each question in the space provided.
- Do **not** use an erasable pen or correction fluid.
- Do **not** write on any bar codes.
- You may use a calculator.
- You should show all your working and use appropriate units.

### INFORMATION

- The total mark for this paper is 120.
- The number of marks for each question or part question is shown in brackets [ ].
- The Periodic Table is printed in the question paper.

This document has **32** pages. Blank pages are indicated.

1 (a) Fig. 1.1 is a diagram of the alimentary canal and associated organs.

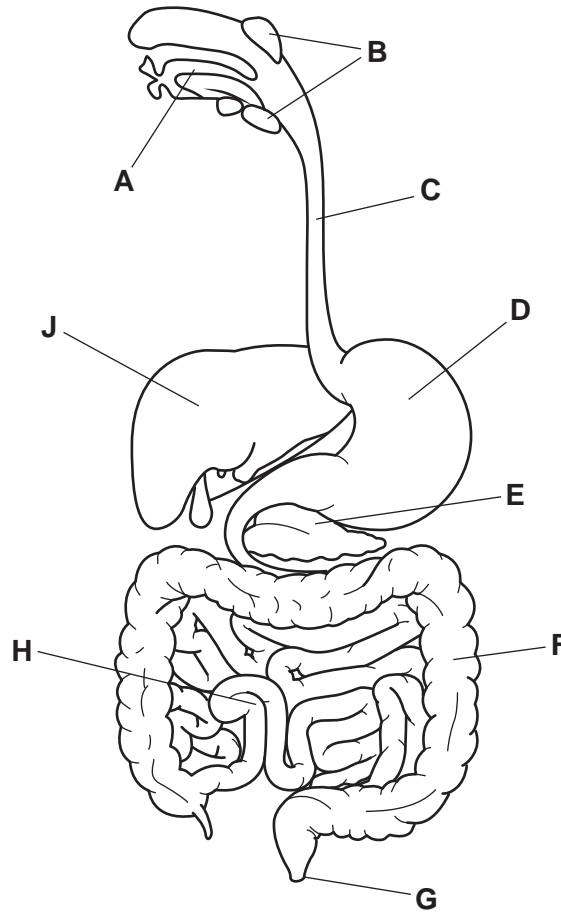

Fig. 1.1

(i) State the letters in Fig. 1.1 that identify where:

- egestion occurs .....
- ingestion occurs .....
- saliva is produced .....
- water is absorbed. ....

[4]

(ii) Name the organ labelled **J** in Fig. 1.1.

..... [1]

(iii) Name the organ labelled **E** in Fig. 1.1.

..... [1]

- (b) A student has written an incorrect definition for digestion in a human.

The definition the student has written is shown in Fig. 1.2.

---

*Digestion is the breakdown of large, insoluble food molecules into small, oil-soluble molecules using mechanical and industrial processes.*

---

**Fig. 1.2**

Circle the **two** incorrect terms in the definition shown in Fig. 1.2.

[2]

- (c) Table 1.1 shows some food molecules and the smaller molecules they are made from.

Complete Table 1.1.

**Table 1.1**

food molecules	smaller molecules
.....	fatty acids and glycerol
.....	amino acids
starch	.....

[3]

[Total: 11]

2 Metal oxides are formed when metals and oxygen react.

Fig. 2.1 shows how magnesium oxide is formed.

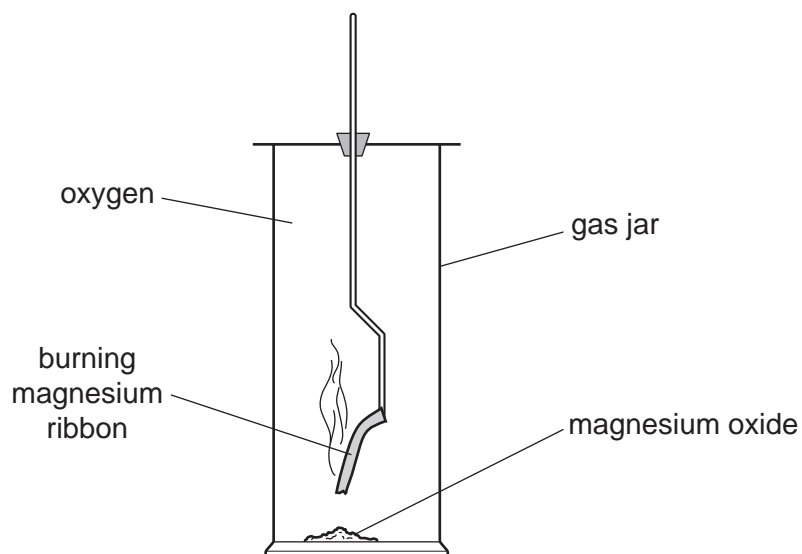

Fig. 2.1

(a) (i) The reaction releases thermal (heat) energy.

State the term used to describe a chemical reaction that releases thermal energy.

..... [1]

(ii) Balance the symbol equation for the formation of magnesium oxide.



(b) Describe **two physical** properties of magnesium.

1 .....

2 .....

[2]

- (c) Excess aqueous hydrochloric acid is added to magnesium and to magnesium oxide as shown in Fig. 2.2.

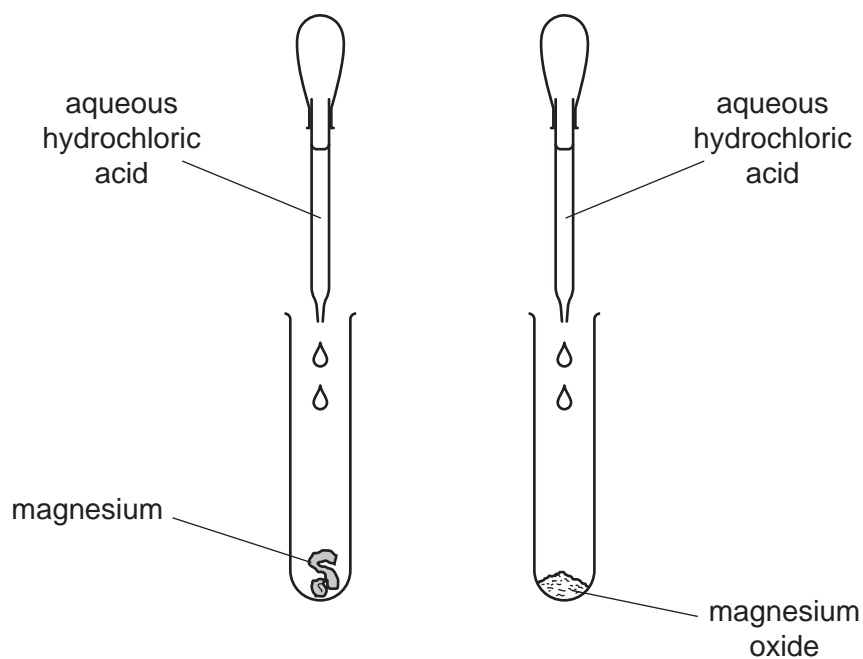

Fig. 2.2

- (i) Magnesium and magnesium oxide both react with aqueous hydrochloric acid.

Describe **one difference** and **one similarity** in the observations made.

difference .....

.....

similarity .....

.....

[2]

- (ii) One of the products made in both reactions in (c)(i) is the same.

State the name of this product.

..... [1]

(d) Aqueous hydrochloric acid is added to copper and to copper(II) oxide.

There is no reaction between the hydrochloric acid and copper.

Copper(II) oxide reacts and dissolves in the acid.

(i) Explain why there is **no** reaction between copper and dilute acid.

Use ideas about the relative positions of elements in the reactivity series.

.....  
 ..... [1]

(ii) Predict whether the solution formed when copper(II) oxide reacts with the acid is coloured or is colourless.

Explain your answer.

.....  
 ..... [1]

(e) Rust is formed when iron reacts with oxygen and another substance.

(i) State the name of the other substance that must be present for iron to rust.

..... [1]

(ii) Barrier methods are used to prevent rusting.

Name **one** substance used in the barrier method of rust prevention.

..... [1]

(iii) State **one** way, other than forming a barrier, that prevents iron from rusting.

.....  
 ..... [1]

[Total: 12]

3 (a) Fig. 3.1 shows a speed–time graph for a bus journey.

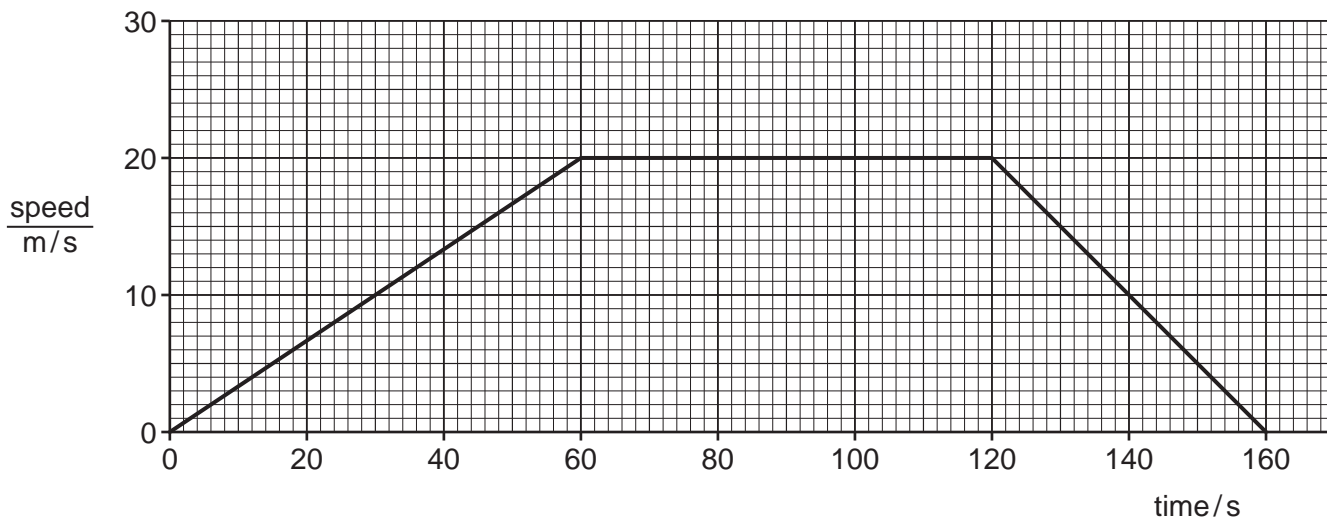

Fig. 3.1

(i) Draw an **X** on the graph where the bus is **not** moving. [1]

(ii) Calculate the distance travelled by the bus in the first 60 s of the journey.

..... m [2]

(b) The bus has a mass of 5000 kg.

(i) Calculate the weight of the bus.

The gravitational field strength  $g$  is 10 N/kg.

weight = ..... N [1]

(ii) State the source of the gravitational field acting on the bus.

..... [1]

(c) Fig. 3.2 shows the forces **A**, **B**, **C** and **D** as the bus moves forward at constant speed.

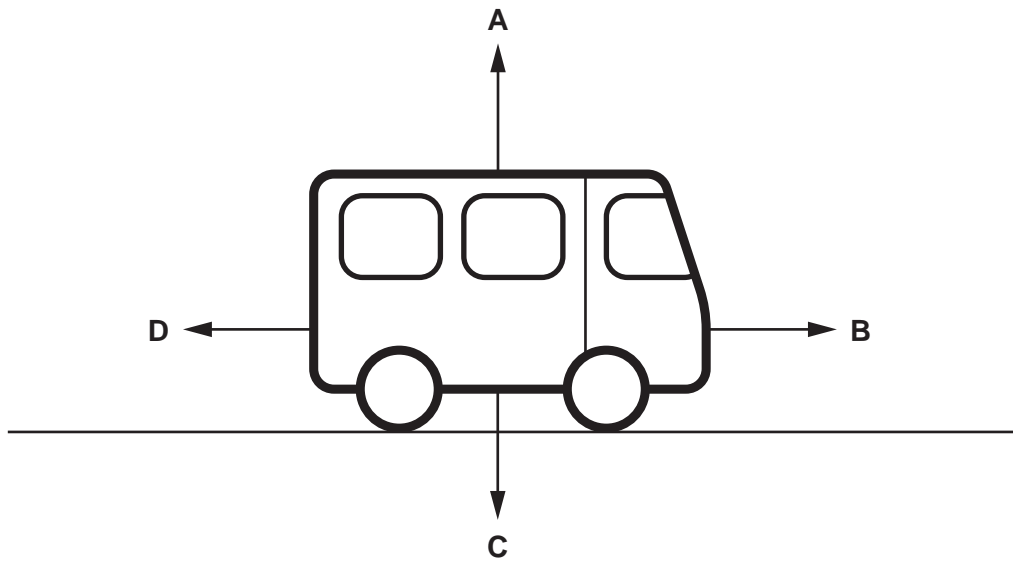

Fig. 3.2

(i) Force **B** is increased.

Describe how this affects the motion of the bus.

..... [1]

(ii) Force **B** is 500 000 N. Force **D** is 100 000 N.

Calculate the resultant force of these two forces.

resultant force = ..... N [1]



(d) The driver changes a wheel.

Fig. 3.3 shows a wrench being used to loosen a wheel nut.

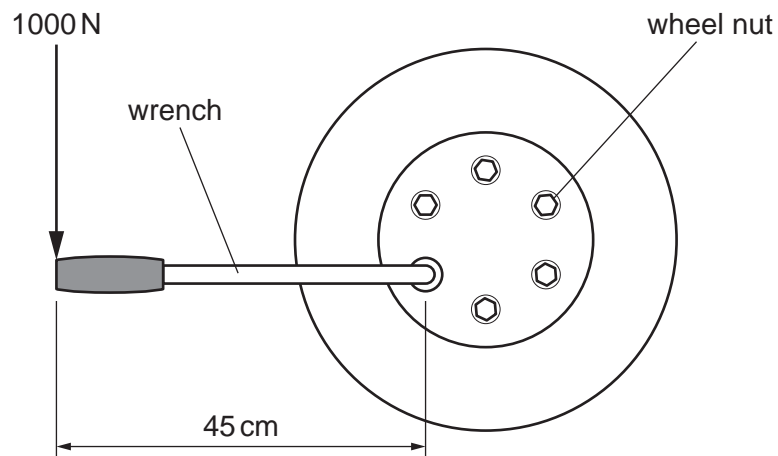

**Fig. 3.3**

The driver applies a force of 1000 N on the wrench.

Calculate the moment of this force on the wheel nut.

moment = ..... Nm [3]

[Total: 10]

- 4 (a) A scientist investigates the recovery time of an athlete and a non-athlete after exercise. Recovery time is the time taken for the pulse rate to return to normal after exercise.

The results are shown in Fig. 4.1.

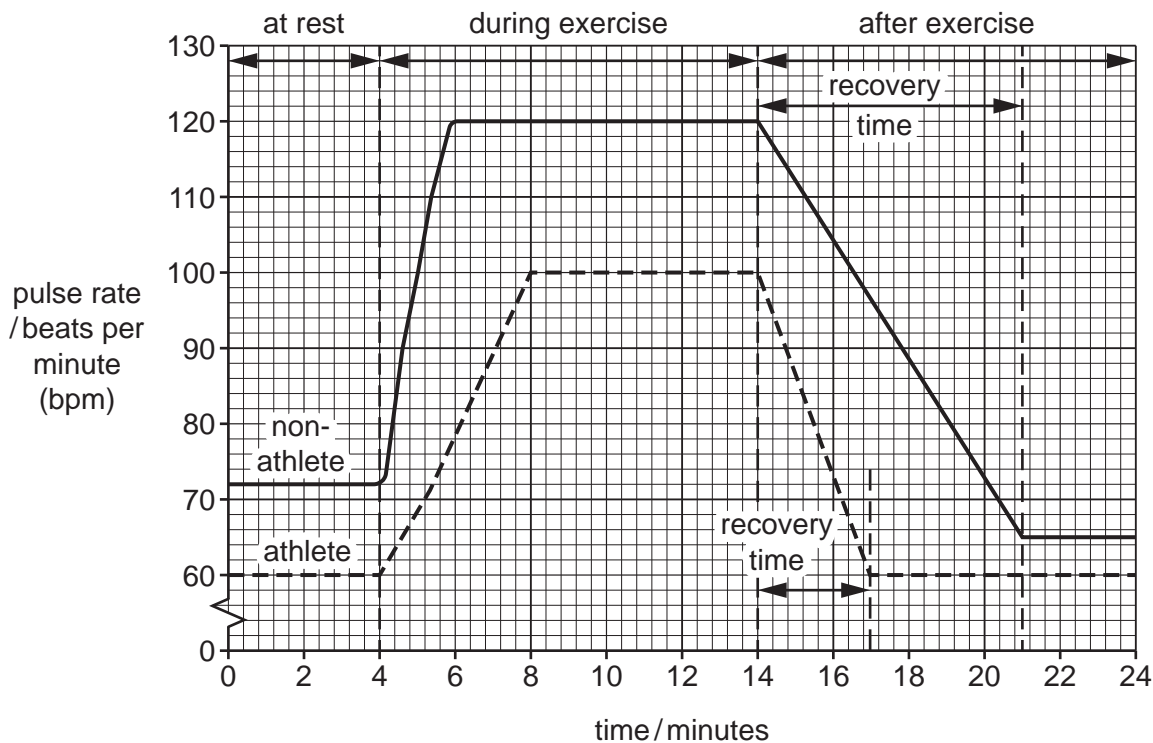
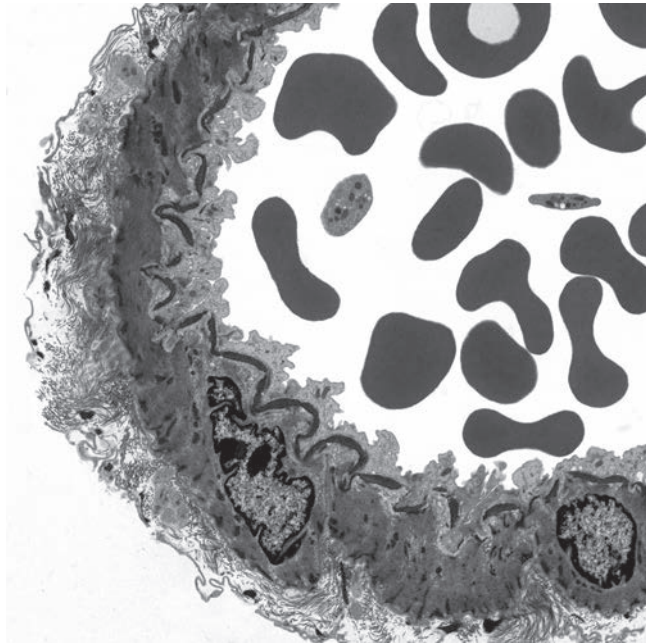

Fig. 4.1

- (i) State the pulse rate of the non-athlete at rest.  
 ..... bpm [1]
- (ii) State the length of recovery time for the athlete and the non-athlete.  
 athlete ..... minutes  
 non-athlete ..... minutes [1]
- (iii) Calculate the difference in recovery times between the athlete and the non-athlete using your answers to (a)(ii).  
 ..... minutes [1]
- (iv) Describe the changes to the pattern of breathing of the non-athlete between 4 and 8 minutes.  
 .....  
 .....  
 ..... [2]

- (b) During exercise there is increased blood flow through the blood vessels.

Fig. 4.2 is a photomicrograph of a cross-section through an artery.



**Fig. 4.2**

- (i) State **one** piece of evidence from Fig. 4.2 that shows this blood vessel is an artery.

.....  
 ..... [1]

- (ii) Name **one** component of blood visible in Fig. 4.2.

..... [1]

- (c) The heart is responsible for pumping blood around the body.

- (i) Name the structure that separates the right and the left sides of the heart.

..... [1]

- (ii) Name the type of tissue the walls of the heart are made from.

..... [1]

[Total: 9]

5 Thermal decomposition happens when compounds are heated and break down into simpler substances.

(a) Limestone thermally decomposes to produce lime in a lime kiln.

Fig. 5.1 shows a lime kiln.

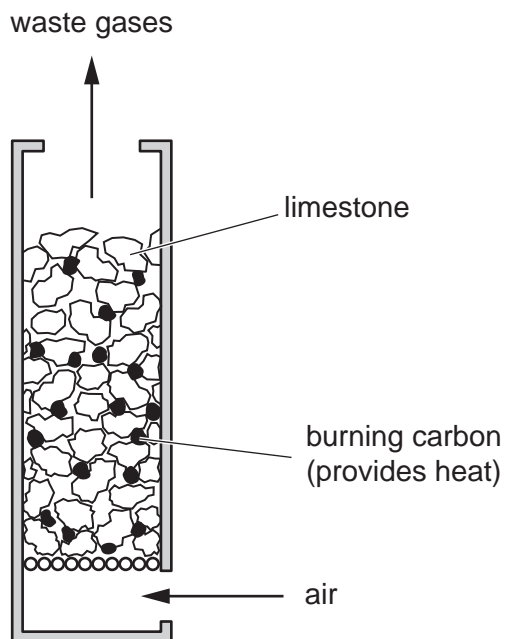

Fig. 5.1

(i) State the chemical names of limestone and lime.

limestone .....

lime .....

[2]

(ii) Suggest why the limestone and carbon inside the lime kiln are in small pieces.

.....

..... [1]

(iii) Explain why farmers often treat soil with limestone.

.....

..... [1]

(b) Fig. 5.2 shows apparatus used for the thermal decomposition of sodium hydrogencarbonate.

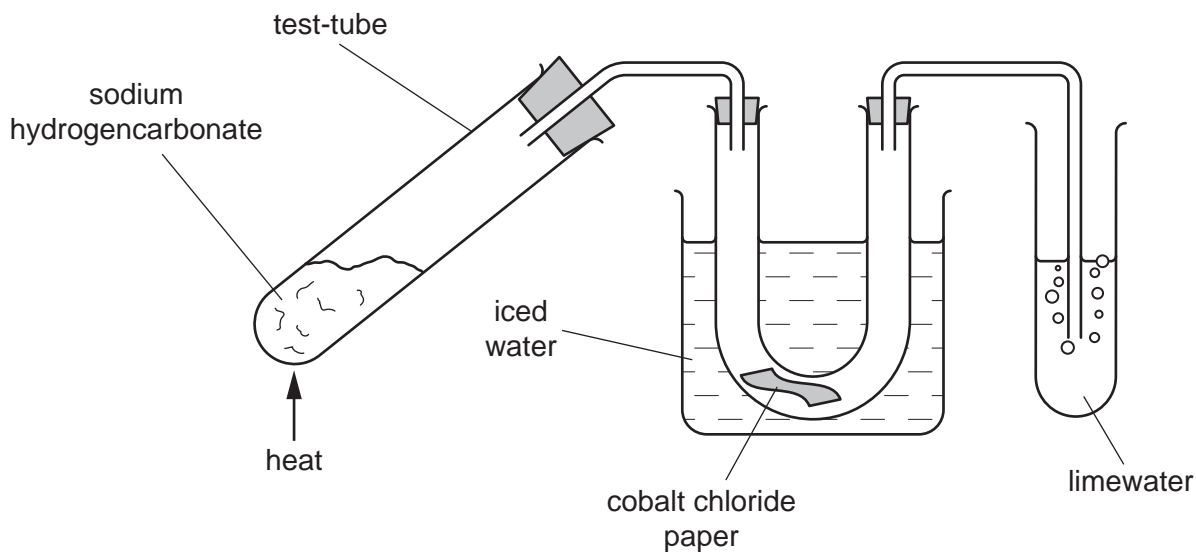
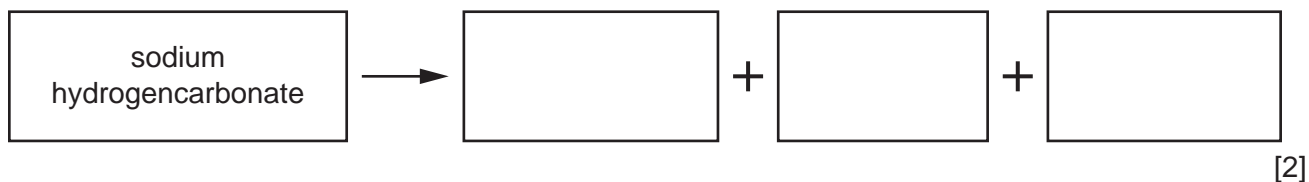

Fig. 5.2

When the sodium hydrogencarbonate in the test-tube is heated for several minutes, the following observations are made.

- A gas is released that turns limewater milky.
- The cobalt chloride paper changes colour from blue to pink.
- A different compound, sodium carbonate, remains in the test-tube.

(i) Use this information to complete the **word** equation for the thermal decomposition of sodium hydrogencarbonate.



(ii) The mass of sodium carbonate that remains after the reaction is smaller than the original mass of sodium hydrogencarbonate.

Explain why.

.....

..... [1]

(c) Cracking of hydrocarbons is another example of thermal decomposition.

Fig. 5.3 shows the cracking of hydrocarbons.

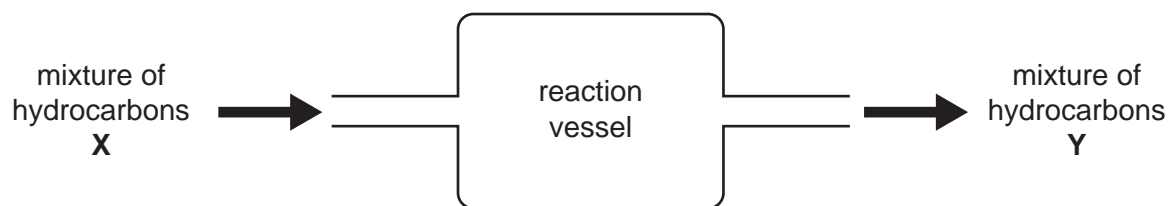

Fig. 5.3

(i) Both **X** and **Y** in Fig. 5.3 are mixtures of hydrocarbons.

Describe **two** ways in which molecules in mixture **X** are different from molecules in mixture **Y**.

1 .....

.....

2 .....

.....

[2]

(ii) Predict the change in colour, if any, when mixture **Y** is shaken with aqueous bromine.

..... [1]

[Total: 10]

**BLANK PAGE**

6 (a) A car is driven along a road.

(i) State the type of energy the car has due to its motion.

..... [1]

(ii) During the journey, the car becomes electrostatically charged.

State what has been added to or removed from the car for it to become charged.

..... [1]

(iii) After the journey, the car needs to be refuelled at a gasoline (petrol) station.

State the type of energy stored in the fuel.

..... [1]

(iv) Not all of the energy stored in the fuel is transferred to the forward motion of the car.

Explain why this is.

.....  
 ..... [1]

(b) An electric car may be recharged by solar cells.

Complete the sentences to describe how a solar cell can provide energy.

Light energy from the ..... is absorbed by the solar cell.

The solar cell changes the light energy to ..... energy.

[2]

(c) The electric car has a powerful d.c. motor.

The turning effect of the motor can be increased by increasing the number of turns on the coil in the motor.

State **one** other way to increase the turning effect of the d.c. motor.

..... [1]



- (d) (i) The two headlamps of the car are powered by the car battery.

The lamps are connected in parallel.

Complete the circuit diagram in Fig. 6.1 to show the two lamps connected in parallel, both controlled by one switch.

The battery has been drawn for you.

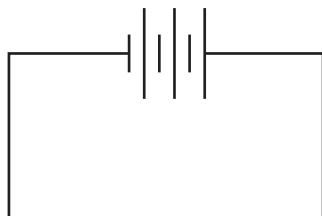

Fig. 6.1

[3]

- (ii) State **one** advantage of connecting the lamps in parallel.

..... [1]

[Total: 11]

- 7 (a) A student investigates the changes to plant cells when they are immersed in different concentrations of sugar solutions.

Fig. 7.1 shows a plant cell before immersion in a sugar solution.

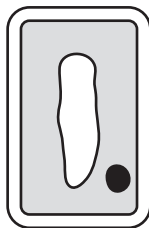

Fig. 7.1

Fig. 7.2 shows the concentrations of the sugar solutions used and the appearance of the cells after immersion.

concentration of sugar solution	final appearance of plant cell
no sugar	<b>A</b> 
low	<b>B</b> 
medium	<b>C</b> 
high	<b>D</b> 

Fig. 7.2

(i) On Fig. 7.2, draw lines to link each concentration of sugar solution to the final appearance of the plant cell. [3]

(ii) Suggest which plant cell, **A**, **B**, **C** or **D**, was placed in a solution of the same concentration as the plant cell.

..... [1]

(b) The change in appearance of the plant cells is caused by osmosis.

Describe the process of osmosis.

.....  
.....  
..... [2]

(c) Water and carbon dioxide are the raw materials needed for photosynthesis.

(i) State **two other** requirements needed for photosynthesis.

1 .....  
2 ..... [2]

(ii) Complete the flowchart to show the pathway of water through a plant.

..... → root cortex cells → ..... → mesophyll cells [2]

(d) Plants use photosynthesis to make their own nutrients.

State the term used to describe organisms that use photosynthesis to make their own nutrients.

..... [1]

[Total: 11]

8 Electrolysis is used to extract some elements from their ores.

(a) Aluminium is extracted using electrolysis.

State the name of the ore from which aluminium is extracted.

..... [1]

(b) Use words from the list to complete the sentences about electrolysis.

Each word may be used once, more than once or not at all.

**boiling**      **chemical**      **current**      **electron**      **evaporation**

**melting**      **physical**      **reacting**      **resistance**      **voltage**

In electrolysis, an electric ..... passes through an electrolyte.

The electrolyte is made either by dissolving a compound in water or by

..... it.

Electrolysis is an example of a ..... change.

[3]

(c) Fig. 8.1 shows three sets of apparatus, **Q**, **R** and **S**, that a student uses to investigate electrolysis.

Each beaker contains aqueous solutions of different compounds. All of the electrodes are inert.

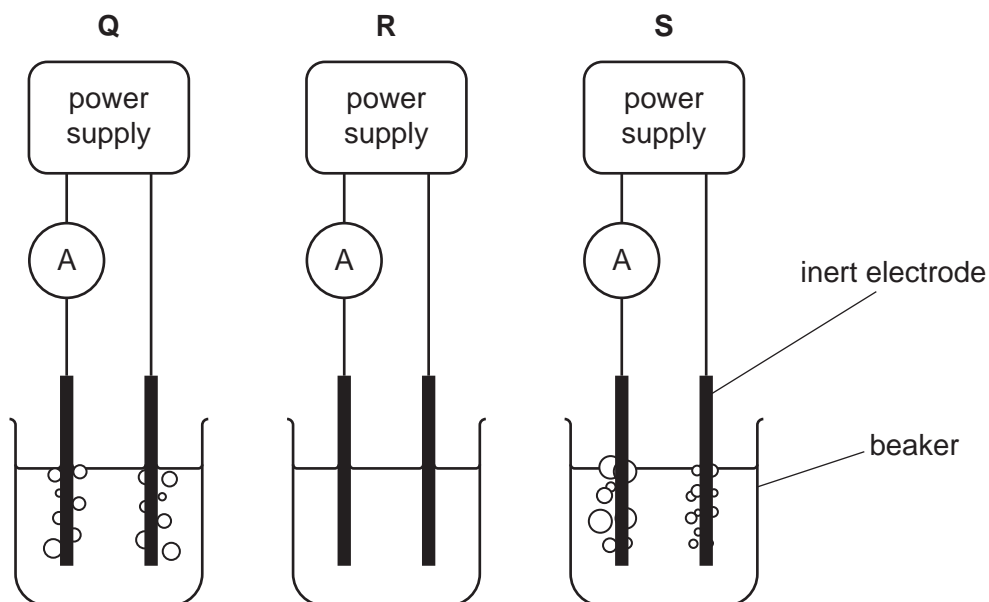

Fig. 8.1

Table 8.1 shows the observations the student makes.

**Table 8.1**

apparatus	cathode product	anode product	ammeter reading/A
<b>Q</b>	hydrogen gas	chlorine gas	0.2
<b>R</b>	no product	no product	0.0
<b>S</b>	hydrogen gas	oxygen gas	0.2

(i) Suggest the compound that is dissolved to form the electrolyte in apparatus **Q**.

..... [1]

(ii) Suggest a reason why the solution in apparatus **R** does **not** conduct.

.....  
 ..... [1]

(iii) The electrolyte in apparatus **S** is an aqueous acid.

Suggest the name of this acid.

..... [1]

(d) Atoms and ions contain protons and electrons.

Protons and electrons are electrically charged particles.

(i) Explain why a potassium atom is electrically neutral.

Use ideas about the charges on the particles in your answer.

.....  
 ..... [2]

(ii) Explain why a potassium ion has an electrical charge of +1.

Your answer should include:

- how a potassium ion is formed
- why it has a charge of +1.

.....  
 .....  
 ..... [2]

[Total: 11]

9 Beneath the surface of the Earth, solid rocks are heated and form liquid rock (magma) and gases.

(a) (i) On Fig. 9.1, draw lines to link each state of matter with the correct arrangement of particles.

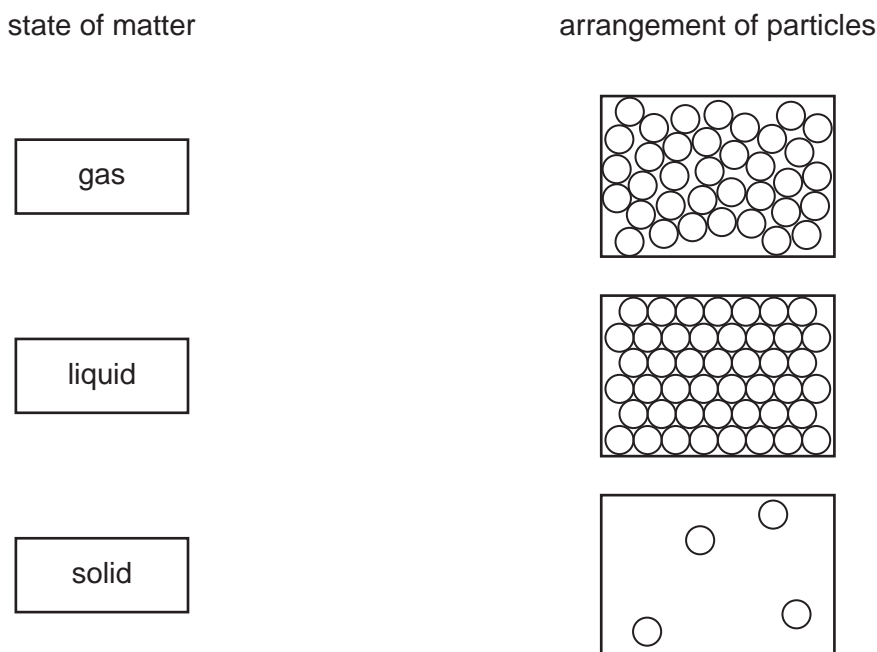

Fig. 9.1

[1]

(ii) In some places, the hot magma comes to the surface as lava.

Some hot lava flows into water in a lake.

A liquid-in-glass thermometer is used to measure the temperature of the water in the lake.

The liquid in the thermometer rises as the water in the lake is heated.

Explain why the liquid in the thermometer is able to show the increase in temperature.

.....

..... [1]

(iii) A different thermometer has no scale on it.

Describe how melting ice and boiling water can be used to identify fixed points on this thermometer.

.....

.....

..... [2]

- (b) People standing near the hot lava feel the thermal energy being emitted by infrared radiation.

On Fig. 9.2, place infrared radiation in the correct place on the incomplete electromagnetic spectrum.

gamma rays					microwaves	
------------	--	--	--	--	------------	--

**Fig. 9.2**

[1]

- (c) A cooled sample of lava is tested for radioactivity.

Describe how a radiation detector is used to determine if  $\alpha$ -particles are being emitted.

.....

.....

..... [2]

- (d) The lava contains the isotope potassium-40.

The nuclide notation is  ${}_{19}^{40}\text{K}$ .

State the number of protons and neutrons in the nucleus of potassium-40.

number of protons .....

number of neutrons .....

[2]

[Total: 9]

10 (a) Complete the sentences about the nervous system using words from the list.

Each word may be used once, more than once or not at all.

- backbone
- brain
- chemical
- electrical
- nerve
- peripheral

There are two parts to the human nervous system. The central nervous system and the ..... nervous system.

The central nervous system consists of the ..... and the spinal cord.

Responses are coordinated by impulses, which are ..... signals passed along ..... cells called neurones.

[4]

(b) Fig. 10.1 shows a type of neurone.

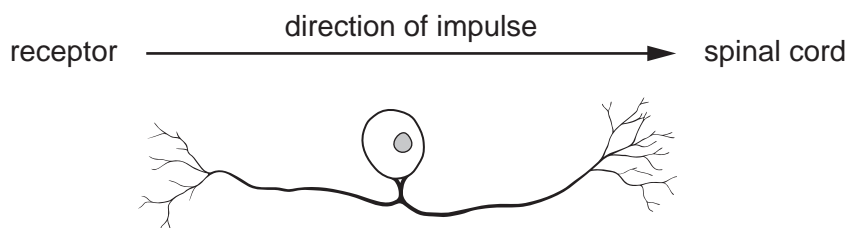

Fig. 10.1

Identify the type of neurone shown in Fig. 10.1.

..... [1]

(c) Hormones coordinate and regulate responses.

A hormone controls the response in shoots and roots in plants.

(i) Describe the response of the shoots **and** roots to gravity.

Include the name of the response in your answer.

.....

.....

.....

.....

..... [3]



(ii) Name **one other** stimulus that shoots and roots respond to.

..... [1]

[Total: 9]

11 Carbon occurs as a free element in the Earth's crust.

Carbon also occurs in millions of different compounds.

(a) Fig. 11.1 shows the structures of two forms of carbon, **A** and **B**.

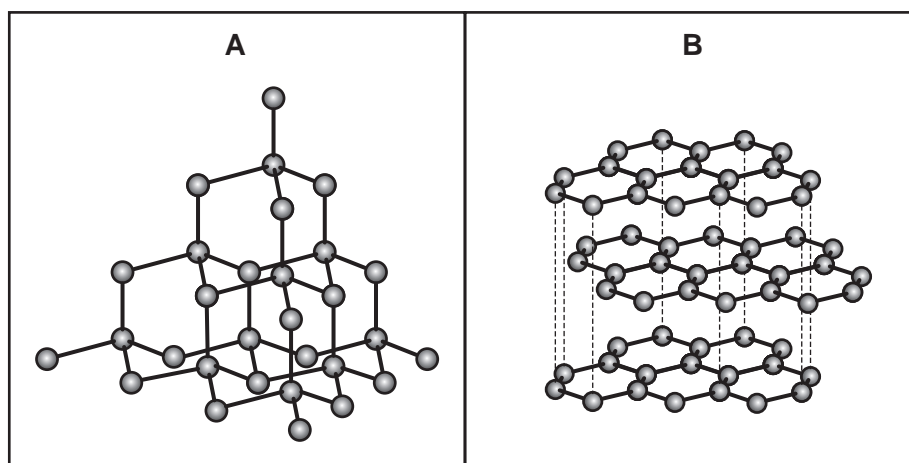

Fig. 11.1

(i) State the names of these forms of carbon.

**A** .....

**B** .....

[2]

(ii) State the type of chemical bonding and structure present in both **A** and **B**.

type of bonding .....

type of structure .....

[2]

(b) The pie charts in Fig. 11.2 show the compositions of two gas mixtures, **L** and **M**.

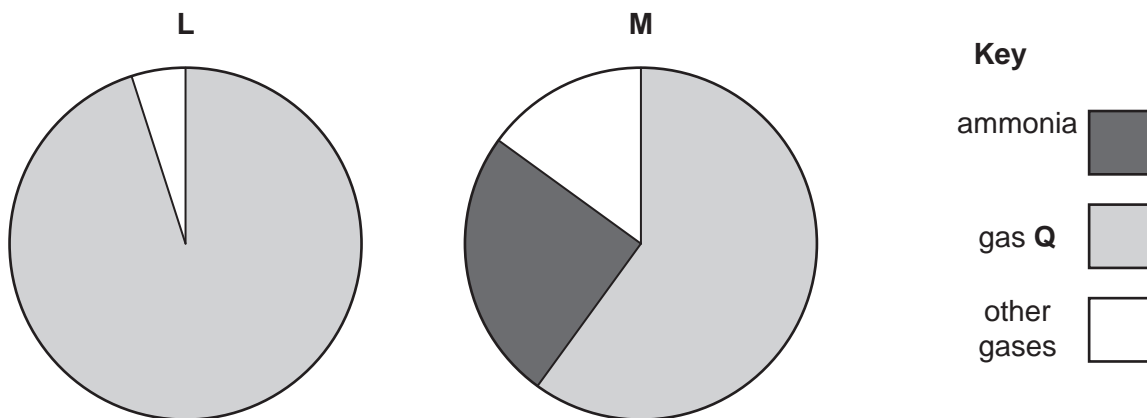

Fig. 11.2

(i) Gas mixture **L** is the fossil fuel, natural gas.

Identify gas **Q**.

..... [1]

(ii) A student wants to distinguish between mixture **L** and mixture **M**.

Describe a test he can do. Include the results in each case.

test .....

result with **L** .....

result with **M** .....

[2]

[Total: 7]

12 (a) Fig. 12.1 shows a boy looking into a plane mirror.

He can see the reflection of an apple.

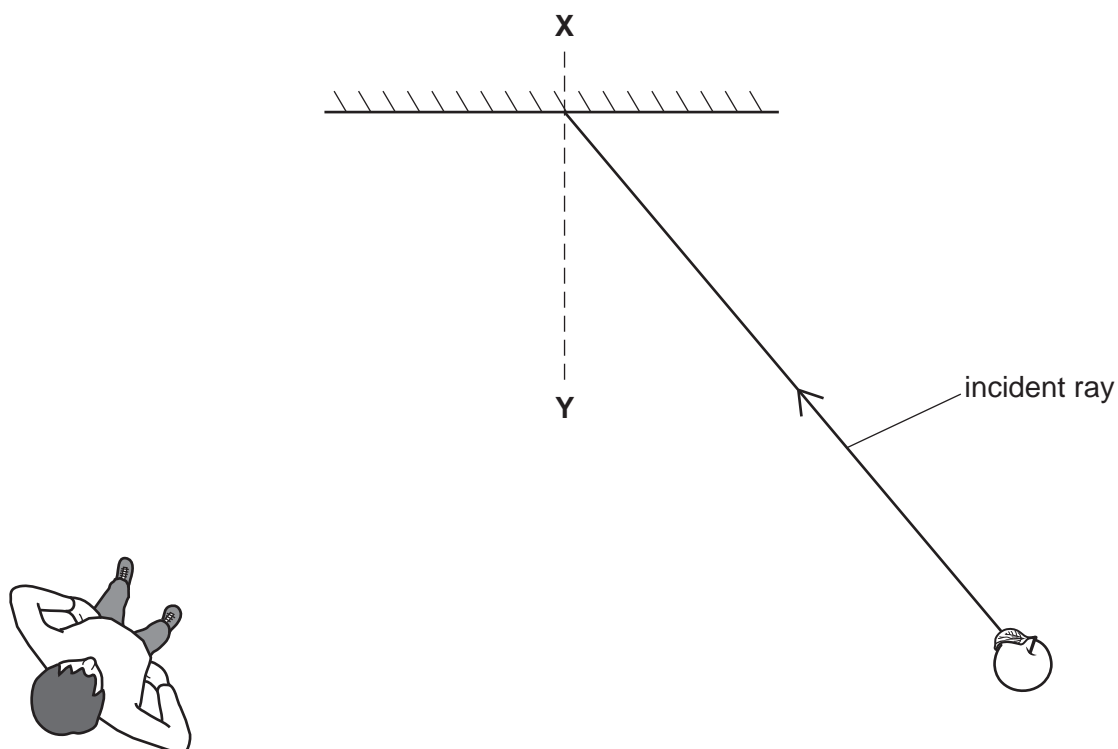

Fig. 12.1

(i) Name the line **XY** shown on Fig. 12.1.

..... [1]

(ii) On Fig. 12.1, draw the reflected ray to the boy **and** label with the words **reflected ray**. [1]

(iii) On Fig. 12.1, mark the angle of incidence **and** label with the letter **i**. [1]

(iv) Circle the **two** correct words or phrases that describe the image of the apple in the mirror.

**diminished**      **enlarged**      **laterally inverted**      **same size**      **upside down**

[2]

- (b) The boy takes a photograph of the apple using a digital camera with a thin converging lens as shown in Fig. 12.2.

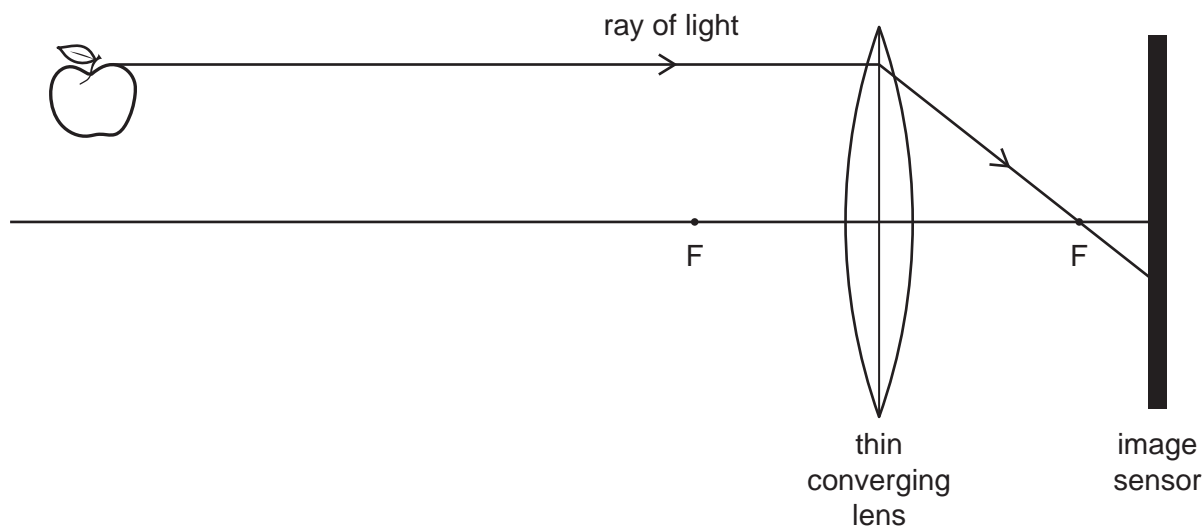

Fig. 12.2

- (i) On Fig. 12.2, draw a ray of light from the bottom of the apple to show where it will be detected on the image sensor of the camera. [2]
- (ii) On Fig. 12.2, draw a double-headed arrow ( $\longleftrightarrow$ ) to show the focal length of the lens. [1]
- (c) To improve the photograph, the boy uses the camera flash. The flash is a lamp operated by a cell and a switch.

The current in the lamp is 0.5A.

The voltage across the lamp is 6V.

Calculate the resistance of the lamp.

resistance = .....  $\Omega$  [2]

[Total: 10]





## The Periodic Table of Elements

Group																							
I	II																III	IV	V	VI	VII	VIII	
3 <b>Li</b> lithium 7	4 <b>Be</b> beryllium 9	<b>Key</b> atomic number atomic symbol name relative atomic mass																5 <b>B</b> boron 11	6 <b>C</b> carbon 12	7 <b>N</b> nitrogen 14	8 <b>O</b> oxygen 16	9 <b>F</b> fluorine 19	10 <b>Ne</b> neon 20
11 <b>Na</b> sodium 23	12 <b>Mg</b> magnesium 24																	1 <b>H</b> hydrogen 1	13 <b>Al</b> aluminium 27	14 <b>Si</b> silicon 28	15 <b>P</b> phosphorus 31	16 <b>S</b> sulfur 32	17 <b>Cl</b> chlorine 35.5
19 <b>K</b> potassium 39	20 <b>Ca</b> calcium 40	21 <b>Sc</b> scandium 45	22 <b>Ti</b> titanium 48	23 <b>V</b> vanadium 51	24 <b>Cr</b> chromium 52	25 <b>Mn</b> manganese 55	26 <b>Fe</b> iron 56	27 <b>Co</b> cobalt 59	28 <b>Ni</b> nickel 59	29 <b>Cu</b> copper 64	30 <b>Zn</b> zinc 65	31 <b>Ga</b> gallium 70	32 <b>Ge</b> germanium 73	33 <b>As</b> arsenic 75	34 <b>Se</b> selenium 79	35 <b>Br</b> bromine 80	36 <b>Kr</b> krypton 84						
37 <b>Rb</b> rubidium 85	38 <b>Sr</b> strontium 88	39 <b>Y</b> yttrium 89	40 <b>Zr</b> zirconium 91	41 <b>Nb</b> niobium 93	42 <b>Mo</b> molybdenum 96	43 <b>Tc</b> technetium —	44 <b>Ru</b> ruthenium 101	45 <b>Rh</b> rhodium 103	46 <b>Pd</b> palladium 106	47 <b>Ag</b> silver 108	48 <b>Cd</b> cadmium 112	49 <b>In</b> indium 115	50 <b>Sn</b> tin 119	51 <b>Sb</b> antimony 122	52 <b>Te</b> tellurium 128	53 <b>I</b> iodine 127	54 <b>Xe</b> xenon 131						
55 <b>Cs</b> caesium 133	56 <b>Ba</b> barium 137	57–71 lanthanoids	72 <b>Hf</b> hafnium 178	73 <b>Ta</b> tantalum 181	74 <b>W</b> tungsten 184	75 <b>Re</b> rhenium 186	76 <b>Os</b> osmium 190	77 <b>Ir</b> iridium 192	78 <b>Pt</b> platinum 195	79 <b>Au</b> gold 197	80 <b>Hg</b> mercury 201	81 <b>Tl</b> thallium 204	82 <b>Pb</b> lead 207	83 <b>Bi</b> bismuth 209	84 <b>Po</b> polonium —	85 <b>At</b> astatine —	86 <b>Rn</b> radon —						
87 <b>Fr</b> francium —	88 <b>Ra</b> radium —	89–103 actinoids	104 <b>Rf</b> rutherfordium —	105 <b>Db</b> dubnium —	106 <b>Sg</b> seaborgium —	107 <b>Bh</b> bohrium —	108 <b>Hs</b> hassium —	109 <b>Mt</b> meitnerium —	110 <b>Ds</b> darmstadtium —	111 <b>Rg</b> roentgenium —	112 <b>Cn</b> copernicium —	114 <b>Fl</b> flerovium —	116 <b>Lv</b> livermorium —	—	—	—	—						

57 <b>La</b> lanthanum 139	58 <b>Ce</b> cerium 140	59 <b>Pr</b> praseodymium 141	60 <b>Nd</b> neodymium 144	61 <b>Pm</b> promethium —	62 <b>Sm</b> samarium 150	63 <b>Eu</b> europium 152	64 <b>Gd</b> gadolinium 157	65 <b>Tb</b> terbium 159	66 <b>Dy</b> dysprosium 163	67 <b>Ho</b> holmium 165	68 <b>Er</b> erbium 167	69 <b>Tm</b> thulium 169	70 <b>Yb</b> ytterbium 173	71 <b>Lu</b> lutetium 175
89 <b>Ac</b> actinium —	90 <b>Th</b> thorium 232	91 <b>Pa</b> protactinium 231	92 <b>U</b> uranium 238	93 <b>Np</b> neptunium —	94 <b>Pu</b> plutonium —	95 <b>Am</b> americium —	96 <b>Cm</b> curium —	97 <b>Bk</b> berkelium —	98 <b>Cf</b> californium —	99 <b>Es</b> einsteinium —	100 <b>Fm</b> fermium —	101 <b>Md</b> mendelevium —	102 <b>No</b> nobelium —	103 <b>Lr</b> lawrencium —

The volume of one mole of any gas is 24 dm<sup>3</sup> at room temperature and pressure (r.t.p.).