

## Static Electricity

### Questions

Q1.

This question is about static electricity.

A student has a rubber balloon tied to a long piece of cotton thread.

The student gives the balloon an overall electrostatic charge.

(i) Describe **one** way that the student could give the balloon an overall electrostatic charge.

(2)

.....

.....

.....

.....

(ii) The student gives the balloon an overall negative charge.

Which of these sentences explains why the overall charge on the balloon is negative?

(1)

- A** Negative charge has been removed from the balloon.
- B** Negative charge has been added to the balloon.
- C** Positive charge has been removed from the balloon.
- D** Positive charge has been added to the balloon.

(iii) The student charges another balloon on a long thread.

Explain how the student can show that the two balloons have the same type of charge.

(3)

.....

.....

.....

.....

.....

.....

**(Total for question = 6 marks)**

**Q2.**

Complete the following sentences using words from the box below.

electrostatic      friction      gravitational      magnetic
--

(i) The force that keeps the Earth in orbit around the sun is  
..... attraction. (1)

(ii) The force that opposes motion between two surfaces is  
..... (1)

(iii) The force that can move small pieces of paper towards a plastic comb  
is ..... attraction. (1)

**(Total for question = 3 marks)**

**Q3.**

A student gives a plastic strip an overall electric charge.

(i) Describe **one** way that the student can give the plastic strip an overall electric charge. (1)

.....

.....

(ii) Figure 1 shows a gold leaf electroscope that can be used to investigate static electricity.

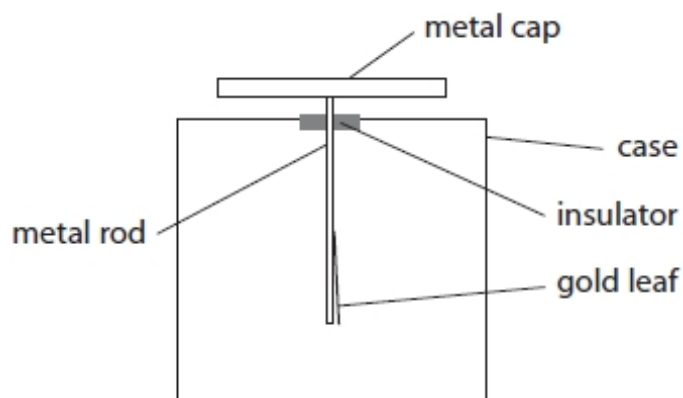

**Figure 1**

The electroscope has no overall charge. The gold leaf has a very small mass and can bend very easily. The student brings a negatively charged plastic strip near to the cap of the electroscope.

The gold leaf bends away from the metal rod. Which diagram shows the way that electric charge is now distributed?

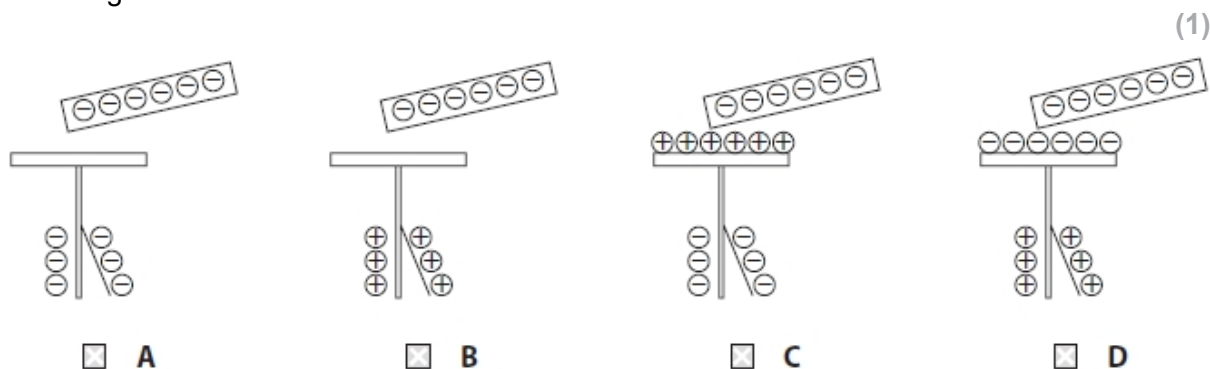

**(Total for question = 2 marks)**

**Q4.**

Figure 3 shows two charged metal plates.

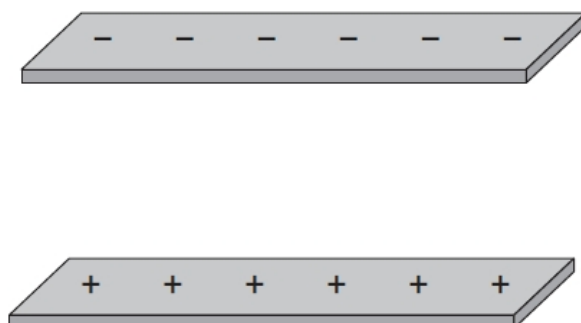
**Figure 3**

The top plate has a negative electric charge. The bottom plate has a positive electric charge.

On Figure 3, draw the electric field lines between the two plates and show the direction of this electric field.

**(Total for question = 2 marks)****Q5.**

Figure 15 shows two parallel metal plates.

The plates are charged using a very high voltage.

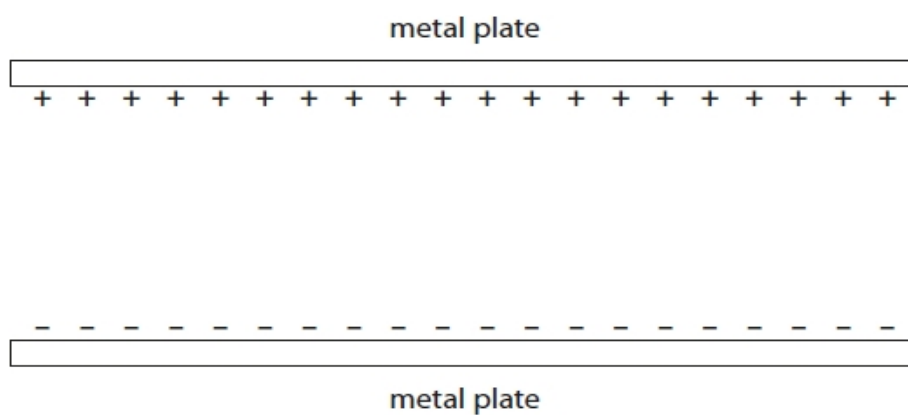
**Figure 15**Draw on Figure 15 the shape and direction of the electric field **between** the plates.**(2)****(Total for question = 2 marks)**

**Q6.**

Two small objects, P and Q, are each given an electric charge.

Figure 3 represents the electric fields around the objects, P and Q.



**Figure 3**

(i) Use information from Figure 3 to give **two** differences between the charge on P and the charge on Q.

(2)

1 .....

.....

2 .....

.....

(ii) Object P and object Q are held near to each other so that their electric fields interact with each other.

State the effect that the electric field of object Q has on object P.

(1)

.....

.....

**(Total for question = 3 marks)**

**Q7.**

Figure 2a shows another gold leaf electroscope that has been given an overall negative charge.

A student connects the metal cap of the charged electroscope to earth with a piece of wire as shown in Figure 2b.

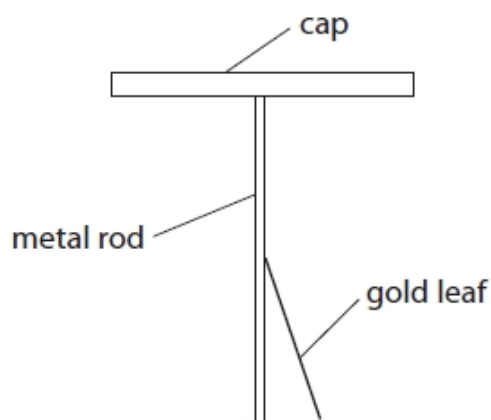
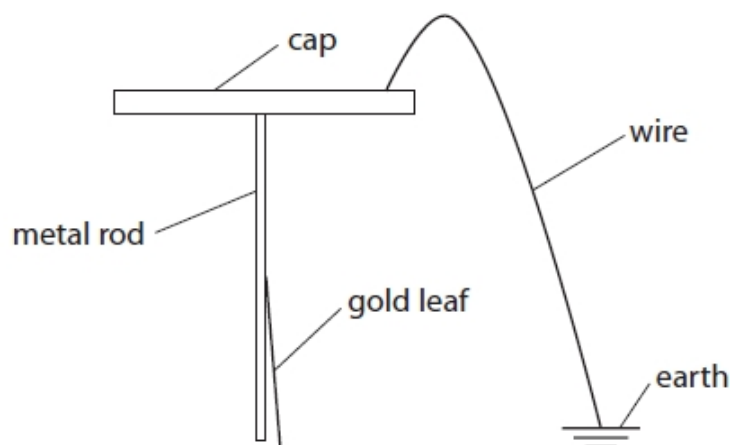
**Figure 2a****Figure 2b**

Explain why the gold leaf has moved.

(2)

.....

.....

.....

.....

**(Total for question = 2 marks)**

**Q8.**

Figure 13 shows part of a cloud, above the ground.  
The base of the cloud is negatively charged.



**Figure 13**

Explain how lightning is produced between the cloud and the Earth.  
Your answer should refer to induced charges.  
You may add to the diagram in Figure 13 to help your answer.

(3)

.....

.....

.....

.....

.....

.....

**(Total for question = 3 marks)**

**Q9.**

A student uses a cloth to give a plastic rod a positive charge.

(i) Explain how the rod becomes positively charged.

(3)

.....

.....

.....

.....

.....

.....

(ii) Figure 12 shows four light balls, Q, R, S and T.

Each ball is suspended on a nylon string.

Balls Q, R and T are coated with a conducting material.

Ball S is an insulator.

Q and S have no charge, R is positively charged and T is negatively charged.

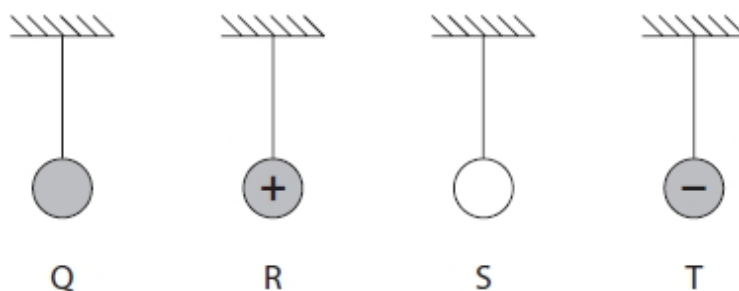

**Figure 12**

The student brings the positively charged rod near to each ball in turn.  
Which ball is repelled by the positively charged rod?

(1)

- A** Q
- B** R
- C** S
- D** T

**(Total for question = 4 marks)**





**Q11.**

This question is about static electricity.

Figure 26 shows a plastic block and a metal disc with an insulating handle.

The top surface of the plastic block has a negative charge.

The metal disc has no overall electric charge.

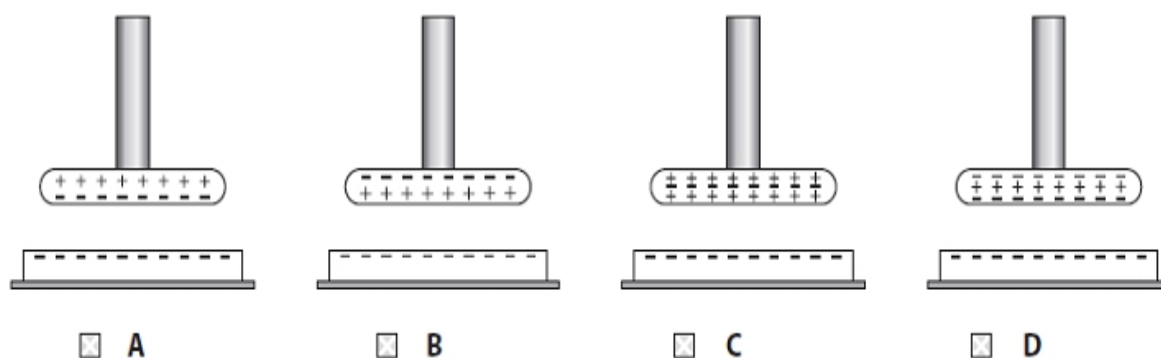

**Figure 26**

A student uses the insulating handle to hold the metal disc above the plastic block.

(i) Which of these diagrams shows how the charge is distributed on the metal disc?

(1)



(ii) The student keeps holding the metal disc above the charged plastic block and taps the metal disc with a finger.

This earths the metal disc for a short time.

Explain why the disc now has an overall positive charge.

(2)

.....

.....

.....

.....

(iii) Figure 27 shows the charges on part of the metal disc and the plastic block.

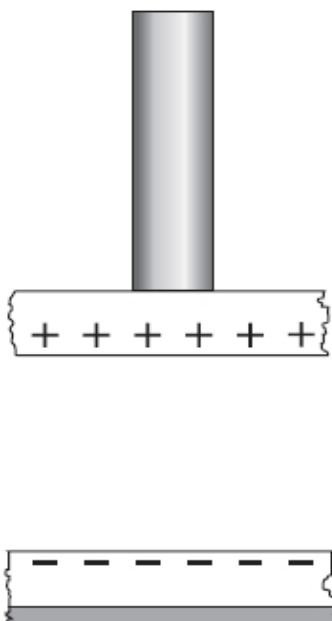

**Figure 27**

On Figure 27, draw lines to show the shape and direction of the electric field between the metal disc and the plastic block.

(2)

**(Total for question = 5 marks)**

**Q12.**

\* Figure 14 shows fuel being transferred to an aeroplane.

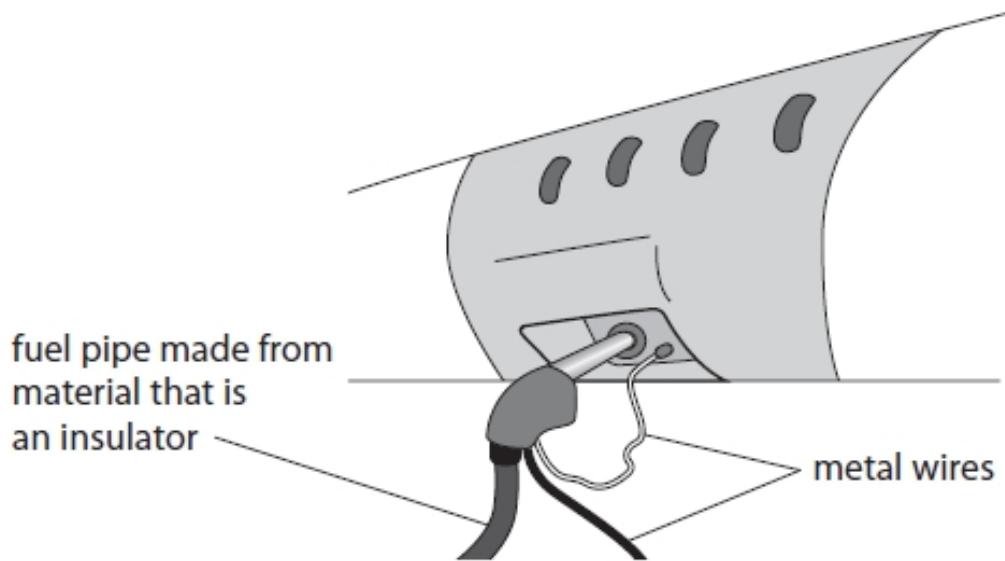

**Figure 14**

Explain why transferring fuel can be dangerous and how the use of metal wires makes the process much safer.

(6)

.....

.....

.....

.....

.....

.....

.....

.....

.....

.....

.....

.....

.....

.....

.....

**(Total for question = 6 marks)**

**Q13.**

Figure 20 shows two metal spheres.

Metal sphere A is fixed to a table.

Metal sphere B can be moved.

Metal sphere B is placed at a short distance from metal sphere A.

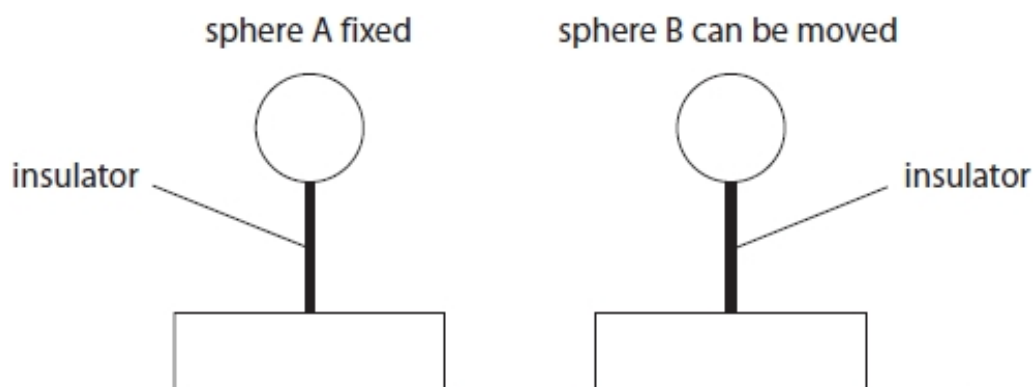

**Figure 20**

Both spheres are insulated from the table and given a negative charge.

The force between the charged spheres is measured.

(i) Explain, in terms of electric fields, why a force is exerted on sphere B.

(2)

.....

.....

.....

.....

(ii) Sphere B is moved and the force between the spheres is measured at several different distances.

Figure 21 is a graph of force on sphere B against distance between the centres of the spheres.

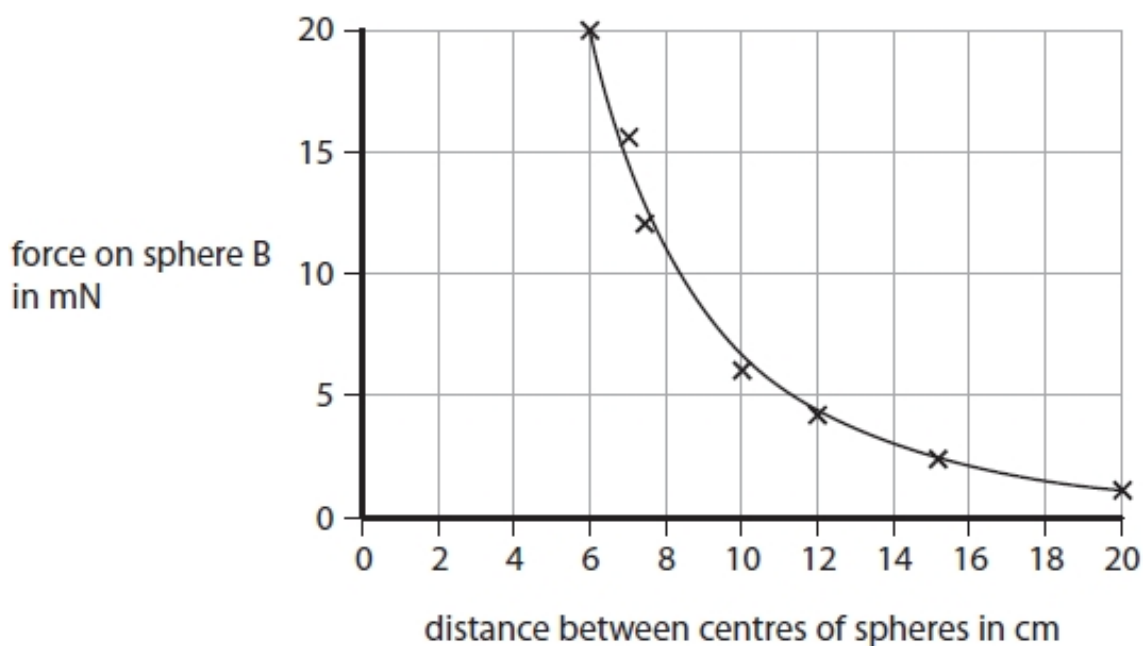

**Figure 21**

Describe how the force on sphere B varies with the distance between the centres of the spheres.

(2)

.....

.....

.....

.....

**(Total for question = 4 marks)**

**Q14.**

Figure 13 shows a negatively charged metal sphere, M.

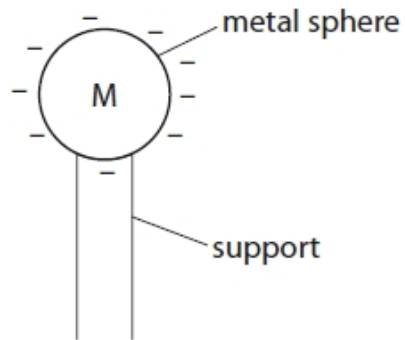

**Figure 13**

(i) Sphere M is negatively charged because it has

- A** gained electrons
- B** lost electrons
- C** gained protons
- D** lost protons

(1)

- (ii) A metal sphere, N, is connected to earth by a wire.  
 N is moved near to M as shown in Figure 14.

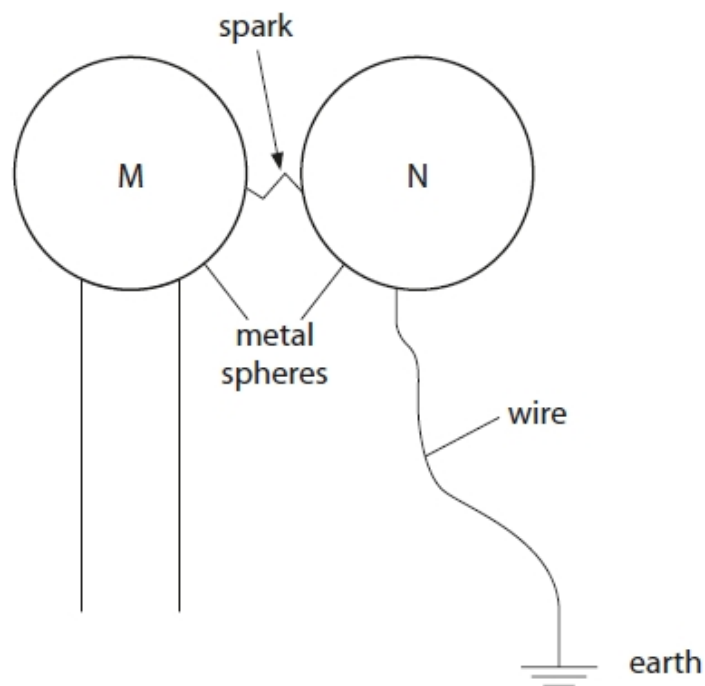

**Figure 14**

A spark jumps between the spheres, discharging sphere M.  
 Describe what happens in the wire connecting sphere N to earth when the spark jumps between M and N.

(2)

.....

.....

.....

.....

- (iii) Describe a use of earthing in everyday life.  
 Your answer should state the use and describe why earthing is needed.

(2)

.....

.....

.....

.....

**(Total for question = 5 marks)**



**Q15.**

A student rubs a plastic comb with a dry cloth to give the comb a positive electric charge.

Figure 19 shows the charged plastic comb picking up small pieces of paper.



(Source © GIPhotoStock/SCIENCE PHOTO LIBRARY)

**Figure 19**

(i) Explain how rubbing the comb with a dry cloth gives the comb a positive electric charge.

(3)

.....

.....

.....

.....

.....

.....

(ii) Explain how the positively-charged plastic comb picks up the small pieces of paper.

(3)

.....

.....

.....

.....

.....

.....

**(Total for question = 6 marks)**

**Q16.**

Which of these diagrams shows the shape and direction of the electric field around a positive point charge?

(1)

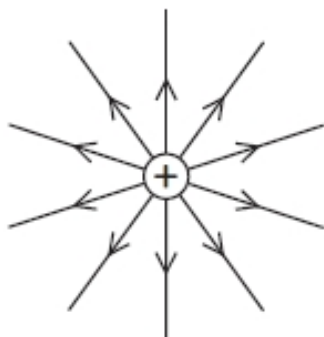
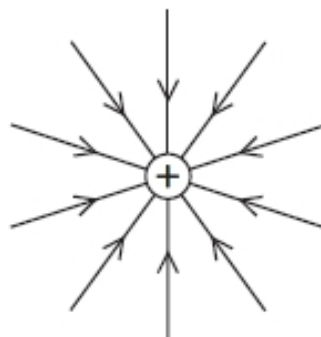
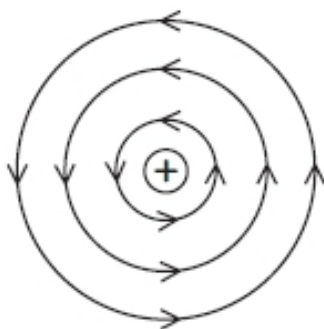
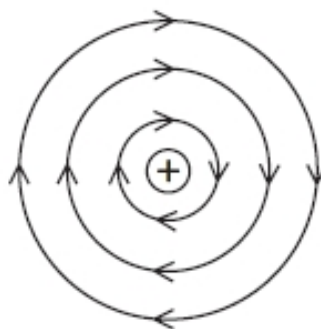
 **A** **B** **C** **D**

(Total for question = 1 mark)

**Q17.**

Figure 1 shows a paint sprayer.

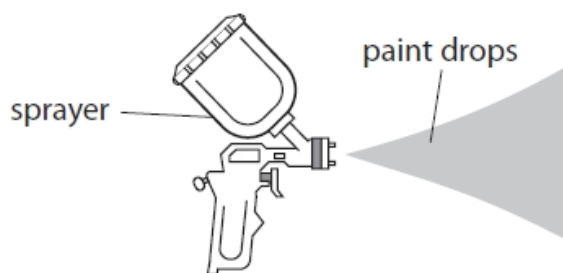

**Figure 1**

Some paint sprayers give the paint drops a positive charge as they leave the sprayer.

(i) The paint drops have a positive charge because the sprayer

(1)

- A** removes electrons from the paint drops
- B** adds electrons to the paint drops
- C** removes protons from the paint drops
- D** adds protons to the paint drops

(ii) Figure 2 shows the spray pattern from two different paint sprayers.



**Figure 2**

Sprayer X does not charge the paint drops. Sprayer Y gives the paint drops a positive charge.

Explain how charging the paint drops changes the shape of the spray pattern.

(2)

.....

.....

.....

.....

(iii) Sprayer Y is used in a factory to paint a metal object.

The object hangs by a metal wire that is connected to earth.

Explain why a metal wire is used to connect the object to earth.

(2)

.....

.....

.....

.....

**(Total for question = 5 marks)**

## Mark Scheme - Static Electricity

Q1.

Question number	Answer	Additional guidance	Mark
(i)	rub (the balloon) (1) with a piece of cloth/hair/fur (1)	use friction allow on any insulated object	(2)
Question number	Answer	Additional guidance	Mark
(ii)	B Negative charge has been added to the balloon  A is incorrect removing negative charge would make the balloon positively charged. C and D are incorrect because positive charge cannot be moved		(1)
Question number	Answer	Additional guidance	Mark
(iii)	an explanation linking:  method of handling balloons without discharging them (1)  bring balloons near to each other (1)  observation of repulsion (1)	hang balloons up by their strings  they/balloons will push away (from each other)	(3)

Q2.

Question number	Answer	Mark
	(i) gravitational (1)	<b>(3)</b> <b>AO1</b>
	(ii) friction (1)	
	(iii) electrostatic (1)	

Q3.

Question number	Answer	Additional guidance	Mark
<b>(i)</b>	use friction (1)	rub (the plastic rod)	<b>(1)</b> <b>AO1</b>

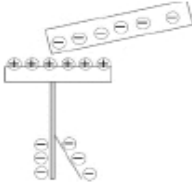
Question number	Answer	Additional guidance	Mark
<b>(ii)</b>	<p>C</p>  <p>A and B are incorrect because the cap would become charged D is incorrect because the cap would have an opposite charge to that on the rod</p>		<b>(1)</b> <b>AO1</b>

Q4.

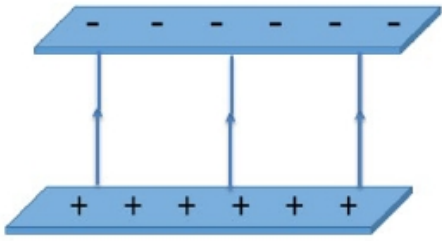
Question Number	Answer	Additional Guidance	Mark
	 <p>at least three vertical straight lines (equally spaced) (1)</p> <p><b>with</b> at least one arrow in the right direction (1)</p>	<p>judge by eye</p> <p>any arrow in the wrong direction = 1 mark max</p>	(2)

Q5.

Question number	Answer	Additional guidance	Mark
	<p>drawing lines to include any <b>two</b> from</p> <p>any vertical line (in between plates) (1)</p> <p>at least two parallel lines (1)</p> <p>any arrow downwards (to show direction) (1)</p>	<p>judge by eye</p> <p>ignore any curved lines at the ends of the plates</p> <p>reject contradicting arrows for this mp</p>	(2) AO1

Q6.

Question number	Answer	Additional guidance	Mark
(i)	(size of) charge on Q is greater than (size of charge) on P (1)  P has (overall) negative charge and Q has (overall) positive charge (1)	in any order  Q has more charge / stronger field than P  accept abbreviations such as +ve, -ve  charge on P is opposite to charge on Q	(2) AO3

Question number	Answer	Additional guidance	Mark
(ii)	(force of) attraction on (object) P from (object) Q (1)		(1) AO1

Q7.

Question number	Answer	Additional guidance	Mark
	An explanation linking:  electrons move_(1)  with <b>one</b> from:  (leaf and/or rod) have been discharged (1)  (gold leaf) is no longer repelled (1)	negative charges move reject positive electrons for this mark  to the earth	(2) AO1



Q8.

Question Number	Answer	Additional guidance	Mark
	<p>An explanation that includes any three of the following points :-</p> <p>ground is charged (by induction) (1)</p> <p>charge on ground is positive (1)</p> <p>electric field builds up (between cloud and ground) (1)</p> <p>air is ionised (1)</p> <p>electrons travel to the ground/positive ions travel to the cloud (1)</p>	<p>May be seen on diagram</p> <p>Award two marks for 'the ground is positively charged'</p> <p>allow electric charge or voltage or potential difference for electric field</p> <p>air becomes a conductor</p> <p>allow charge for ions</p>	<b>(3)</b>

Q9.

Question Number	Answer	Additional guidance	Mark
<b>(i)</b>	<p>An explanation that combines:-</p> <p>rub the rod with a cloth (1)</p> <p>(so)electrons (1)</p> <p>are moved (from rod to cloth) (1)</p>	<p>allow clean off the rod or friction (with the rod)</p> <p>allow <u>negative</u> charges for electrons</p> <p>movement of <u>positive</u> charges can only score the first mark</p> <p>'electrons are positive' can score a maximum of one mark</p> <p>movement of unnamed charges can score third mark</p>	<b>(3)</b>

Question Number	Answer	Mark
(ii)	<p data-bbox="379 280 464 309"><b>B</b> R</p> <div data-bbox="550 280 646 459" style="text-align: center;"><p>The diagram shows a horizontal hatched line representing a fixed support. A vertical line representing a string hangs from the center of this support. At the end of the string is a small circle containing a plus sign (+), representing a positively charged rod labeled 'R' below it.</p></div> <p data-bbox="379 510 758 539"><b>B</b> is the only correct answer.</p> <p data-bbox="379 584 1241 703"><b>A</b> is incorrect because ball Q is coated with a conducting material but is uncharged, a negative charge will be induced on it and it will be attracted not repelled by a positively charged rod.</p> <p data-bbox="379 748 1225 822"><b>C</b> is incorrect because ball S is an insulator and is uncharged and will not be repelled by a positively charged rod.</p> <p data-bbox="379 866 1193 940"><b>D</b> is incorrect because ball T has a negative charge and will be attracted not repelled by a positively charged rod.</p>	<b>(1)</b>

Q10.

Question number	Indicative content	Mark
*	<p>Answers will be credited according to candidate's deployment of knowledge and understanding of the material in relation to the qualities and skills outlined in the generic mark scheme.</p> <p>The indicative content below is not prescriptive and candidates are not required to include all the material which is indicated as relevant. Additional content included in the response must be scientific and relevant.</p> <p style="text-align: center;"><b>AO2 (strand 2) (6 marks)</b></p> <ol style="list-style-type: none"> <li>1. rub a strip with the cloth</li> <li>2. test to see its charge (positive or negative) by rubbing against the coulombmeter</li> <li>3. place the strip in the holder</li> <li>4. charge another strip by friction (rubbing)</li> <li>5. test its charge with the meter</li> <li>6. bring the second strip up towards the one in the holder; either attracts or repels</li> <li>7. repeat 1-6 with another charged strip</li> <li>8. repeat steps 1-3, but then charge an acetate strip, again detecting the sign of its charge, as before</li> <li>9. bring the charged acetate (+) strip up to the charged polythene (-) strip; the one in the stirrup should now be attracted / move towards the other</li> </ol>	<b>(6) AO2</b>

AO targeting: 6 marks AO2 strand 2

Level	Mark	Descriptor
	0	<ul style="list-style-type: none"> <li>No awardable content</li> </ul>
Level 1	1-2	<ul style="list-style-type: none"> <li>The explanation attempts to link and apply knowledge and understanding of scientific enquiry, techniques and procedures, flawed or simplistic connections made between elements in the context of the question.</li> <li>Lines of reasoning are unsupported or unclear. (AO2)</li> </ul>
Level 2	3-4	<ul style="list-style-type: none"> <li>The explanation is mostly supported through linkage and application of knowledge and understanding of scientific enquiry, techniques and procedures, some logical connections made between elements in the context of the question.</li> <li>Lines of reasoning mostly supported through the application of relevant evidence. (AO2)</li> </ul>
Level 3	5-6	<ul style="list-style-type: none"> <li>The explanation is supported throughout by linkage and application of knowledge and understanding of scientific enquiry, techniques and procedures, logical connections made between elements in the context of the question.</li> <li>Lines of reasoning are supported by sustained application of relevant evidence. (AO2)</li> </ul>

### Summary for guidance

Level	Mark	Additional Guidance	General additional guidance – the decision within levels e.g. - At each level, as well as content, the scientific coherency of what is stated will help place the answer at the top, or the bottom, of that level.
	0	No rewardable material.	
Level 1	1–2	<u>Additional guidance</u> A limited explanation with at least two steps of a suitable procedure	<u>Possible candidate responses</u> rub a strip with the cloth / give it a charge place the strip in the holder explains consequent attraction / repulsion
Level 2	3–4	<u>Additional guidance</u> Partially complete explanation of a suitable procedure with at least three steps and some purpose indicated	<u>Possible candidate responses</u> As above with bring a second strip up towards the one in the holder either attracts or repels repeated with like / unlike charges use of coulombmeter
Level 3	5–6	<u>Additional guidance</u> Detailed explanation of a suitable procedure with most steps and a clear logic in what is being proposed	<u>Possible candidate responses</u> As above with test charge with the meter to see if it's (+) or (-) detailed use of acetate / polythene strips with purpose

Q11.

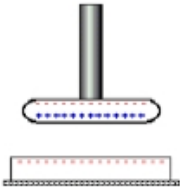
Question number	Answer	Additional guidance	Mark
(i)	<p>B</p>  <p>A and D are incorrect because a negative charge cannot induce a negative charge C is incorrect because the disc is insulated so negative charge cannot be removed</p>		(1)

Question number	Answer	Additional guidance	Mark
(ii)	<p>an explanation linking: <u>electrons / negative</u> charges have flowed (1) from the metal disc / to the student / to earth/ground (1)</p>	reject positive charge moving for first mark	(2)

Question number	Answer	Additional guidance	Mark
(iii)	<p>at least three straight lines joining disc and plastic (1) arrow(s) from disc towards plastic (1)</p>	<p>judge by eye ignore curved lines at edge  do not award mark if there are arrows in both directions</p>	(2)

## Q12.

Question Number	Answer	Mark
	<p>Answers will be credited according to candidate's deployment of knowledge and understanding of the material in relation to the qualities and skills outlined in the generic mark scheme. The indicative content below is not prescriptive and candidates are not required to include all the material which is indicated as relevant. Additional content included in the response must be scientific and relevant.</p> <p style="text-align: center;"><b>AO1 6 marks</b></p> <p><b>dangers</b></p>	<b>(6)</b>
	<ul style="list-style-type: none"> <li>• friction as fuel flows through pipe</li> <li>• build-up of (electrostatic) charge</li> <li>• potential difference between nozzle and plane</li> <li>• causes spark</li> <li>• explosion or fire</li> </ul> <p><b>use of metal wire</b></p> <ul style="list-style-type: none"> <li>• potential is the same on both objects</li> <li>• no electric field</li> <li>• earths excess charge</li> <li>• constant safe discharge</li> <li>• no imbalance of electrons</li> </ul>	

Descriptor
<ul style="list-style-type: none"> <li>• No rewardable material.</li> </ul>
<ul style="list-style-type: none"> <li>• Demonstrates elements of physics understanding, some of which is inaccurate. Understanding of scientific ideas lacks detail. (AO1)</li> <li>• Presents an explanation with some structure and coherence. (AO1)</li> </ul>
<ul style="list-style-type: none"> <li>• Demonstrates physics understanding, which is mostly relevant but may include some inaccuracies. Understanding of scientific ideas is not fully detailed and/or developed. (AO1)</li> <li>• Presents an explanation that has a structure which is mostly clear, coherent and logical. (AO1)</li> </ul>
<ul style="list-style-type: none"> <li>• Demonstrates accurate and relevant physics understanding throughout. Understanding of the scientific ideas is detailed and fully developed. (AO1)</li> <li>• Presents an explanation that has a well-developed structure which is clear, coherent and logical. (AO1)</li> </ul>

Level	Mark	Additional Guidance	General additional guidance – the decision within levels Eg - At each level, as well as content, the scientific coherency of what is stated will help place the answer at the top, or the bottom, of that level.
	0	No rewardable material.	
Level 1	1-2	<u>Additional guidance</u>  Two unlinked statements	<u>Possible candidate responses</u>  make a spark/ explosion/fire there is static electricity fuel is flammable metal wires conduct charge(electricity) could get an electric shock
Level 2	3-4	<u>Additional guidance</u>  Limited explanation <b>linking</b> facts about dangers OR <b>linking</b> facts about why using metal wires is safer	<u>Possible candidate responses</u> A spark is produced because there is a build up of static charge ( electricity )  or build up of static charge prevented(electricity)because the metal wire takes the charge to earth(ground)
Level 3	5-6	<u>Additional guidance</u>  Detailed explanation about dangers AND why using metal wires is safer  (one may be stronger than the other but both should feature for level 3)	<u>Possible candidate responses</u> Spark is caused by the build up of charge (static electricity) AND the build up is prevented by the metal wire taking the charge to earth (ground)



Q13.

Question Number:	Answer	Additional guidance	Mark
(i)	An explanation linking:  sphere A has an electric field (1)  sphere B is in it (1)	both spheres have electric fields  the electric fields interact/overlap  ignore nature of force; e.g. repulsion	(2) AO 2 2

Question Number:	Answer	Additional guidance	Mark
(ii)	a description to include:  as the distance increases the force (on the sphere B) decreases (1)  the greatest change is at smallest distances (1)	negative correlation  non-linear gradient changes  allow named non-linear functions such as exponential / inversely proportional in this context  reference to inverse square law scores 2 marks	(2) AO 3 1a AO 3 1b

Q14.

Question number	Answer	Mark									
i	A gained electrons Options B, C and D are incorrect explanations	(1) AO1									
Question number	Answer	Additional guidance	Mark								
ii	A description to include electrons / negative charges <b>move</b> (1) down the wire / to earth (1)		(2) AO1								
Question number	Answer	Additional guidance	Mark								
iii	A description including one row from: <table border="1" data-bbox="408 869 989 1406"> <thead> <tr> <th>use</th> <th>description</th> </tr> </thead> <tbody> <tr> <td>fuelling cars / plane (1)</td> <td>charge / voltage could build up causing a spark / fire: (avoided by earthing (the pump) (1)</td> </tr> <tr> <td>(insecticide / paint) sprayers (1)</td> <td>earthed object gains (induced) charge(s) to attract paint / insecticide (1)</td> </tr> <tr> <td>kettle / other electrical device (1)</td> <td>earthing the outside prevents shock (to user) (1)</td> </tr> </tbody> </table>	use	description	fuelling cars / plane (1)	charge / voltage could build up causing a spark / fire: (avoided by earthing (the pump) (1)	(insecticide / paint) sprayers (1)	earthed object gains (induced) charge(s) to attract paint / insecticide (1)	kettle / other electrical device (1)	earthing the outside prevents shock (to user) (1)	Other examples are possible  in this context also allow to prevent shock	(2) AO1
use	description										
fuelling cars / plane (1)	charge / voltage could build up causing a spark / fire: (avoided by earthing (the pump) (1)										
(insecticide / paint) sprayers (1)	earthed object gains (induced) charge(s) to attract paint / insecticide (1)										
kettle / other electrical device (1)	earthing the outside prevents shock (to user) (1)										

## Q15.

Question Number:	Answer	Additional guidance	Mark
(i)	<p>an explanation linking 3 of the following:</p> <p>friction (between cloth and comb) (1)</p> <p>transfer of electrons / charge {from plastic comb / on to the cloth} (1)</p> <p>electrons carry a negative charge (1)</p> <p>leaving <b>excess</b> positive charge on the comb (1)</p>	<p>reference to positive electrons or positive charge moving loses that mark point</p> <p>electrons/charges are rubbed off comb (on to cloth)</p> <p>leaving cloth with negative charge</p> <p>more protons than electrons (on the comb)</p>	(3) AO 2 1

Question Number:	Answer	Additional guidance	Mark
(ii)	<p>an explanation linking:</p> <p>a negative charge is induced (1)</p> <p>on the part of the paper closest to the comb (1)</p> <p>opposite charges attract (1)</p>	<p>allow a clear description of induction</p> <p>ignore references to positive charge being moved in this context only</p> <p>force of attraction sufficient to pick up the pieces of paper</p>	(3) AO 2 1

Q16.

Question Number:	Answer	Mark
	<p data-bbox="392 356 416 389">A</p>  <p data-bbox="392 595 855 629"><b>The only correct answer is A</b></p> <p data-bbox="392 667 1158 734"><i>B is not correct because the arrows are in the wrong direction</i></p> <p data-bbox="392 734 1078 768"><i>C is not correct because the field is not circular</i></p> <p data-bbox="392 768 1078 801"><i>D is not correct because the field is not circular</i></p>	<p data-bbox="1279 356 1335 389"><b>(1)</b></p> <p data-bbox="1279 389 1378 423">AO 1 1</p>

Q17.

Question Number	Answer	Mark
(i)	<p><b>The only correct answer is A:</b> It removes electrons from the paint drops</p> <p><b>B is incorrect</b> because that would give an overall negative charge to the drops</p> <p><b>C is incorrect</b> because protons are not transferred</p> <p><b>D is incorrect</b> because protons are not transferred</p>	(1)

Question Number	Answer	Additional Guidance	Mark
(ii)	<p>An explanation linking like charged drops are repelling each other (1)</p> <p>(so) spray is wider (from sprayer Y) (1)</p>	<p>more spread out / finer / larger area / more dispersed</p>	(2)

Question Number	Answer	Additional Guidance	Mark
(iii)	<p>An explanation linking metal (wire) can conduct electrons / charge (from earth) (1)</p> <p>(so) prevent (positive) charge accumulating on object (1)</p>	<p>metal is a conductor</p> <p>discharge (the object)</p>	(2)