

A domestic wind-powered generator

- 1 (a) The picture shows a wind-powered generator used to produce electricity for a house.



© The Wall Street Journal

- (i) The table shows some electrical components.

Put ticks in the table next to the **two** components the generator must contain.

(2)

component	✓
ammeter	
coil of wire	
battery	
magnet	
voltmeter	

- (ii) Explain why the voltage produced by this wind-powered generator is not always the same.

(2)

.....

.....

.....

.....

(iii) It would cost the homeowner 15 p to buy 1.0 kW h of electrical energy from the National Grid.

His generator has a maximum power of 2.0 kW.

The generator produces energy at this maximum power for 3 hours.

Calculate how much it would cost to buy the same amount of energy from the National Grid.

(2)

cost = p

(b) An electric kettle is plugged into a 230 V mains supply.
It has a power of 2.5 kW.

Use this equation to calculate the current in the kettle.

$$\text{current (in amps)} = \frac{\text{power (in watts)}}{\text{voltage (in volts)}}$$

(3)

current = A

(c) Suggest why a 2 kW wind-powered generator may not supply all the electrical energy needed in a house.

(1)

.....

.....

.....

.....

(Total for Question 3 = 10 marks)

Controlling and using electric current

- 2 (a) A technician investigates the potential difference (voltage) across an electrical heater.

This circuit diagram shows the circuit the technician uses.

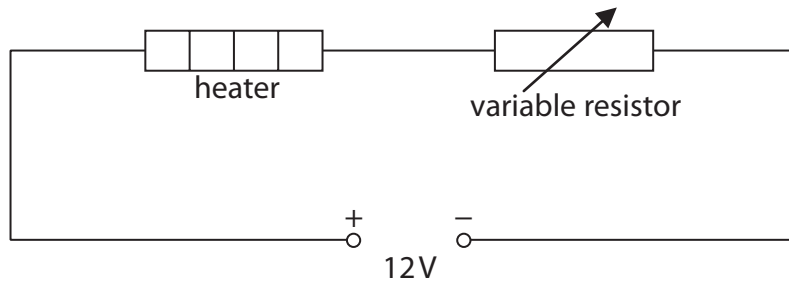

- (i) Add a voltmeter to the circuit which will measure the potential difference (voltage) across the heater.

(2)

- (ii) The resistance of the heater is 15Ω .

The current in the heater is 0.56 A .

Calculate the potential difference (voltage) across the heater.

(2)

potential difference = V

(iii) The technician changes the value of the variable resistor.

She measures the new voltage across the heater and the new current in it.

Here are her results:

$$\text{voltage} = 6.0 \text{ V} \quad \text{current} = 0.40 \text{ A.}$$

Calculate the amount of electrical energy transferred in 30 s by the heater.

(2)

$$\text{energy transferred} = \dots\dots\dots \text{ J}$$

(iv) The total energy supplied by the battery in 30 s is 144 J.

Explain why your answer in (iii) is not the same as the total energy supplied by the battery.

(2)

.....

.....

.....

.....

(b) The graphs show how the current in a component changes with the voltage applied across the component.

Draw a line from each component to its correct graph.

(2)

component

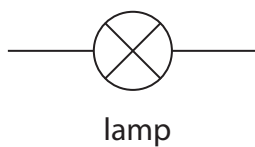
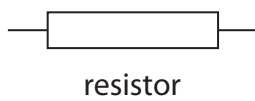
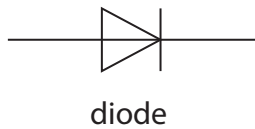

graph

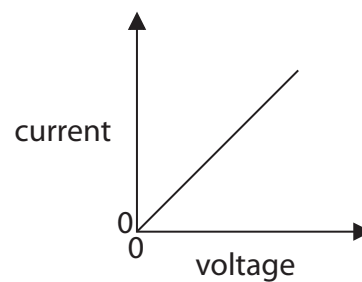
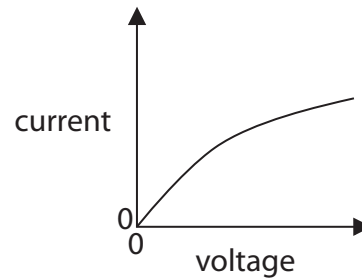
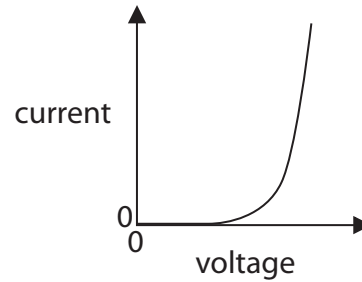

(Total for Question 4 = 10 marks)

Light-dependent resistors

- 3 (a) A technician investigates a light-dependent resistor (LDR) connected in series with a $120\ \Omega$ resistor and a voltage source.

The technician measures the voltage across the LDR and also the current in the LDR.

- (i) Which **one** of these circuits should the technician use?

Put a cross (☒) in the box next to your answer.

(1)

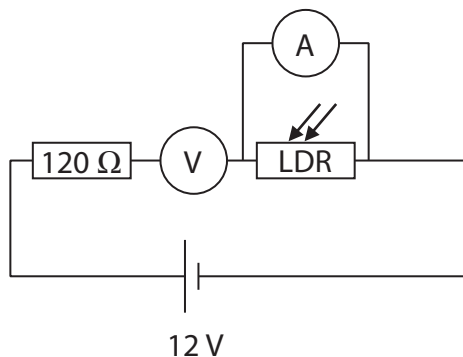

A

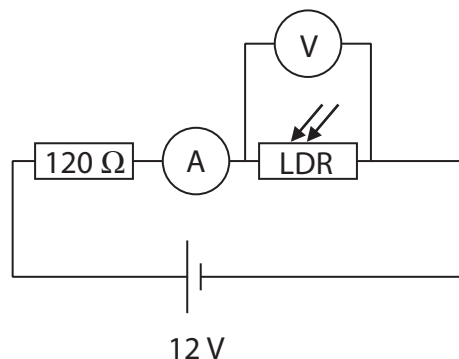

B

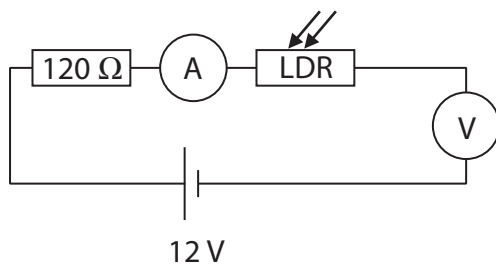

C

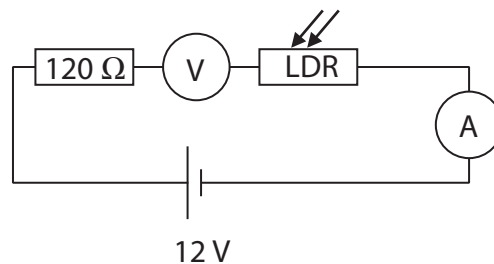

D

- (ii) When the LDR is in bright sunlight, its resistance is $185\ \Omega$.
The voltage across the LDR is then 7.2V .

Show that the current in the LDR is about 0.039 A .

(2)

(iii) Complete the sentence by putting a cross (☒) in the box next to your answer.

The current in the $120\ \Omega$ resistor is

(1)

- A** much more than the current in the LDR
- B** much less than the current in the LDR
- C** the same as the current in the LDR
- D** the opposite of the current in the LDR

(iv) The technician repeats the readings with the LDR in different light conditions.

The table gives two of the readings.

light condition	current in LDR
bright sunlight	0.039 A
cloudy skies	0.028 A

Explain why the two current readings are different.

(2)

.....

.....

.....

.....

Current electricity

4 A student is investigating a filament lamp.

(a) (i) Complete the sentence by putting a cross (☒) in the box next to your answer.

The current in the filament lamp is a flow of

(1)

- A protons
- B neutrons
- C electrons
- D atoms

(ii) The student uses this circuit in his investigation.

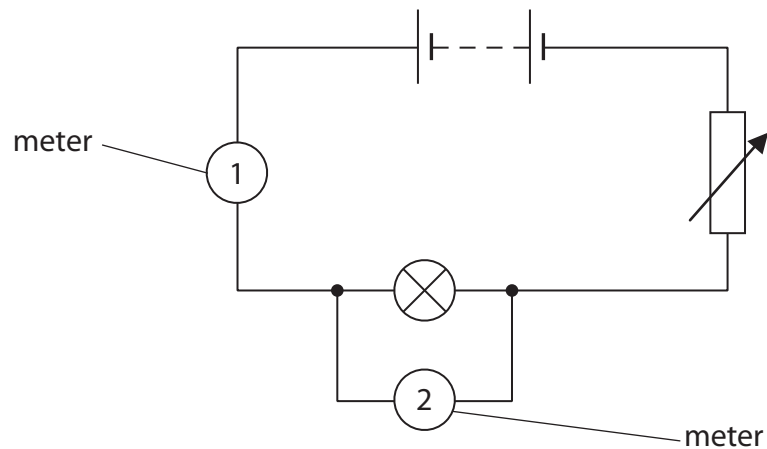

State what is measured by the meters.

(2)

Meter 1 measures

Meter 2 measures

- (b) The normal operating potential difference (voltage) and current of the filament lamp is 6 V, 0.4 A.

Calculate the energy supplied to the lamp under these conditions in 20 s.

(2)

energy = J

- (c) The graph shows how current varies with potential difference (voltage) for another filament lamp.

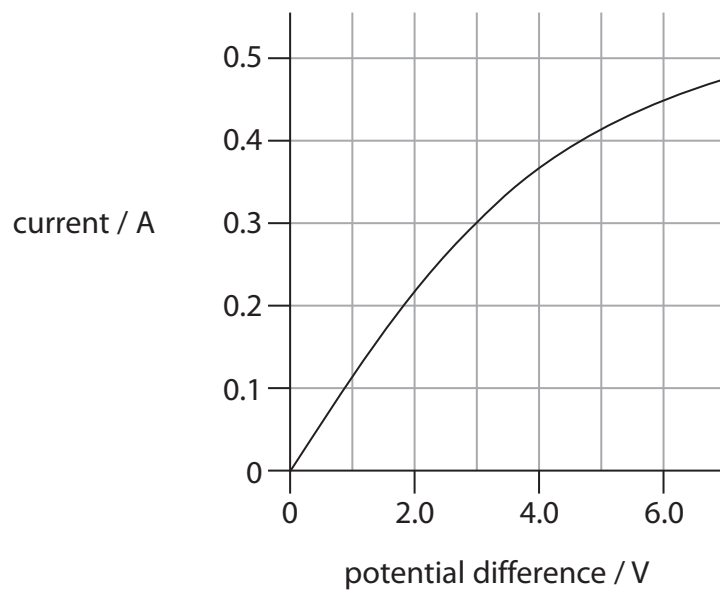

Calculate the resistance of the lamp when the current in the lamp is 0.3 A.

resistance = potential difference \div current ($R = V / I$)

(3)

resistance = Ω

Using electric current

5 A student uses an electric kettle.



It works from the 230 V mains supply.

(a) Complete the sentence by putting a cross (☒) in the box next to your answer.

A potential difference of 1 volt is the same as

(1)

- A** 1 joule per coulomb
- B** 1 joule per ohm
- C** 1 watt per ohm
- D** 1 watt per coulomb

(b) The power of the kettle when it is heating water is 1.8 kW.
The mains voltage is 230 V.

(i) Calculate the current in the kettle.

(3)

current = A

(ii) The kettle is switched on for 2 minutes.

Calculate the total amount of energy transferred by the kettle in this time.

(2)

energy transferred = J

(iii) The heating element of the kettle contains a resistor made from a long length of wire. Explain why an electric current in a resistor makes the resistor heat up.

(2)

.....

.....

.....

.....

(Total for Question 2 = 8 marks)
