

1 (a) The diagram shows the fuel used in some nuclear reactors.

The fuel is contained inside spheres.

The silicon carbide layer of each sphere is designed to contain the fission products for at least one million years.

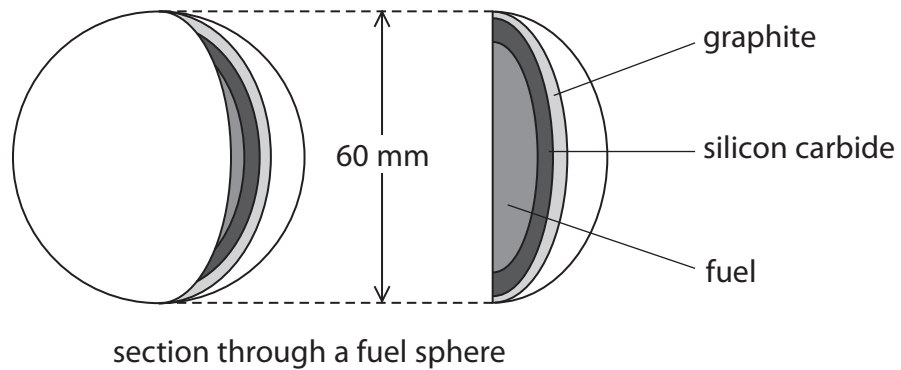

(i) Give the name of a fuel that could be used.

(1)

.....

(ii) Explain what is meant by the term **fission products**.

(2)

.....

.....

.....

.....

(iii) Explain why it is important to contain these fission products for such a long time.

(2)

.....

.....

.....

.....

(iv) The graphite layer in every fuel sphere acts as a moderator.

What is the function of the moderator in a nuclear reactor?

(1)

.....

.....

(v) The nuclear reactor also contains boron control rods.

Explain why it is dangerous to remove most of the control rods from the reactor.

(2)

.....

.....

.....

.....

(b) The reactor is cooled with helium gas.

The gas enters the reactor at 500 °C.

(i) What is this temperature in kelvin?

(1)

temperature = ..... K

(ii) Helium gas enters the reactor at a pressure of 8.40 MPa and leaves the reactor at a temperature of 1170 K.

Calculate the pressure of the helium gas as it leaves the reactor.

[assume the volume of the gas does not change]

(3)

pressure = ..... MPa

**(Total for Question 1 = 12 marks)**