

- 1 (a) A student uses this apparatus to investigate what happens to a current-carrying conductor in a magnetic field.

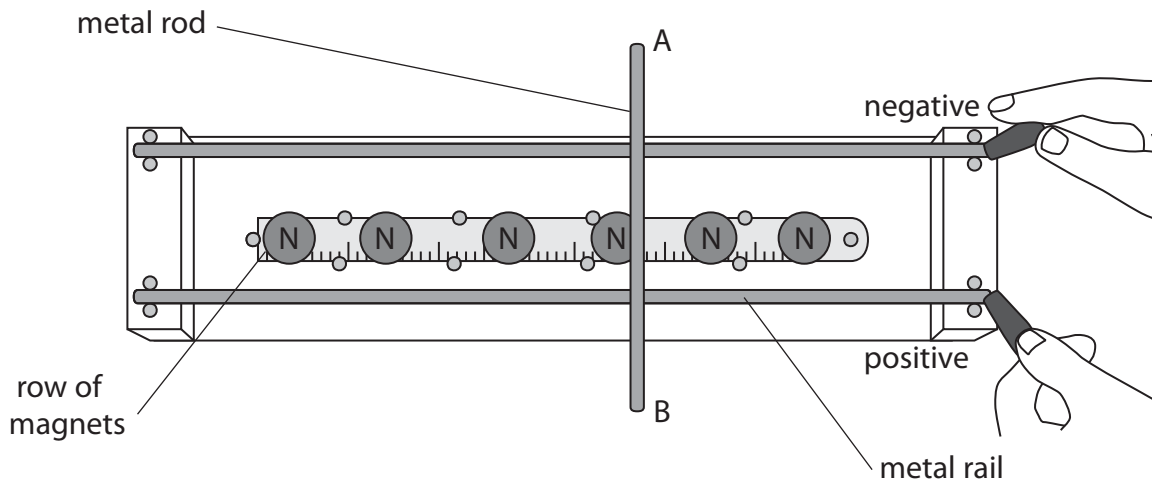

The student connects the two parallel horizontal metal rails to the positive and negative terminals of a power supply.

The metal rod AB rests across the rails and is free to move.

Explain what happens to the metal rod AB.

(4)

.....

.....

.....

.....

.....

.....

.....

.....

.....

.....

.....

.....

.....

.....

.....

.....

.....

.....

.....

.....

.....

.....

.....

(b) This diagram shows the construction of a simple loudspeaker.

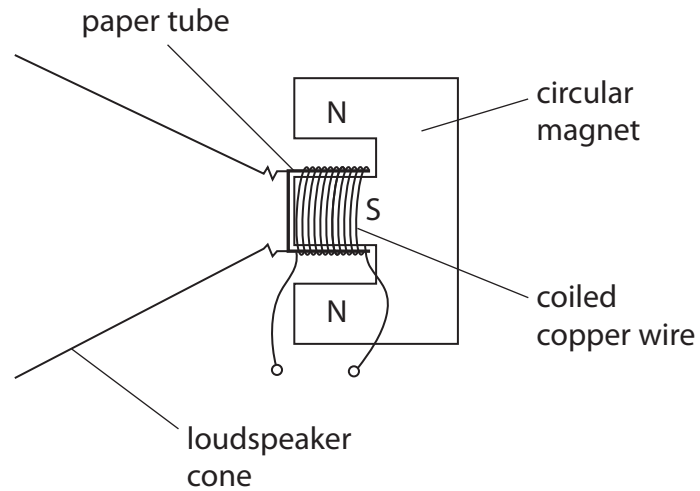

A coil of wire is wrapped around a paper tube attached to the loudspeaker cone.

When there is an alternating current in the coil, the cone moves.

Describe how the alternating current generates a sound wave.

You may draw a diagram if it helps your answer.

(4)

.....

.....

.....

.....

.....

.....

.....

.....

.....

.....

.....

.....

.....

.....

.....

.....

.....

.....

.....

.....

.....

.....

.....

.....

**(Total for Question 1 = 8 marks)**

2 (a) A student uses this apparatus to investigate electromagnetic induction.

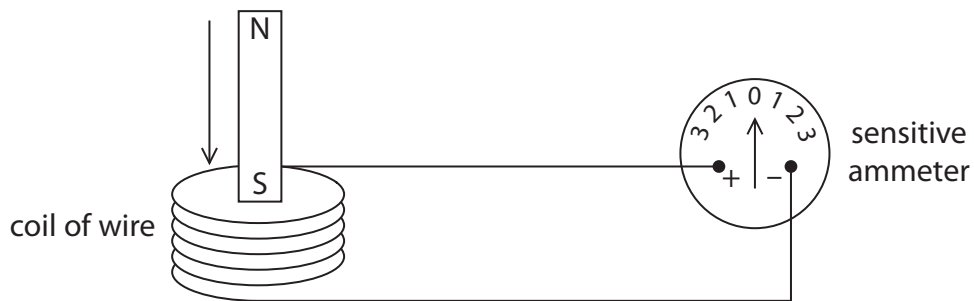

When the S pole of the magnet is moved into the coil, the pointer on the sensitive ammeter moves to the left.

Describe two ways that the student can make the pointer move to the right.

(2)

1.....

.....

2.....

.....

(b) The student has a bicycle with a dynamo (generator) that supplies electricity for its lights. The diagram shows the dynamo.

The friction wheel, W, presses against the bicycle tyre. When the student pedals, the friction wheel turns and causes part Y to rotate.

Key	
W	friction wheel
X	axle
Y	
Z	

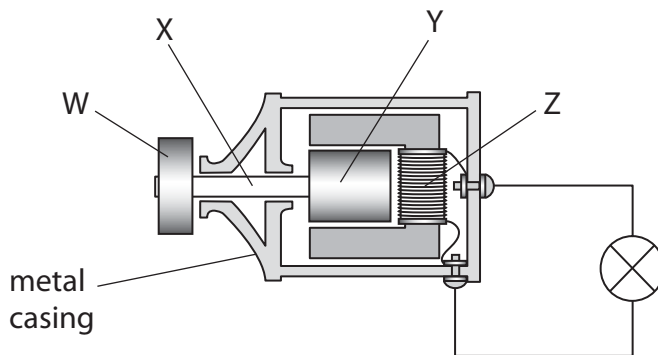

(i) Complete the key for the diagram by giving the names of parts Y and Z.

(2)

- (ii) The graph shows how the output voltage of the dynamo varies with time as the student pedals steadily.

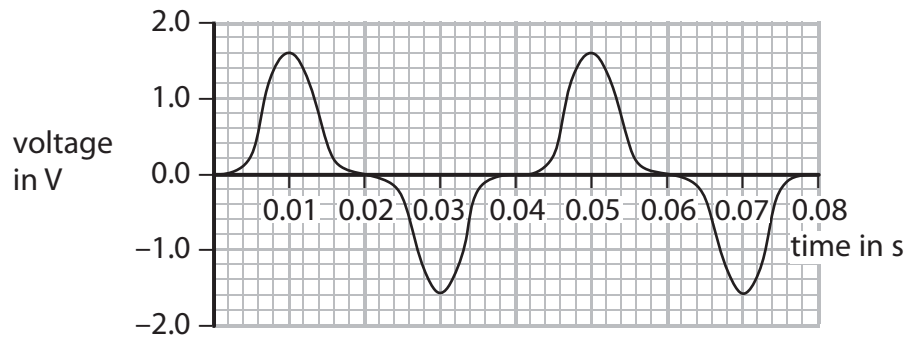

State the maximum output voltage of the dynamo.

(1)

maximum output voltage = ..... V

- (iii) Calculate the frequency of the output voltage.

(2)

frequency = ..... Hz

- (iv) Which row of the table is correct when the friction wheel turns faster?

(1)

	Output voltage is	Frequency of output voltage is
<input type="checkbox"/> <b>A</b>	lower	lower
<input type="checkbox"/> <b>B</b>	higher	lower
<input type="checkbox"/> <b>C</b>	higher	higher
<input type="checkbox"/> <b>D</b>	lower	higher

(v) Apart from changing the speed of the friction wheel, suggest how the output voltage of the dynamo can be increased.

(1)

(c) The student cycles for 290 s.

Her dynamo produces a constant useful power output of 3.1 W and is 72% efficient.

(i) Calculate the total useful energy output.

(3)

useful energy output = ..... J

(ii) State the relationship between efficiency, useful energy output and total energy input.

(1)

(iii) Calculate the total energy input.

(3)

total energy input = ..... J

**(Total for Question 2 = 16 marks)**