

1 Fig. 2.1 shows a dummy of mass 70 kg used in a crash test to investigate the safety of a new car.

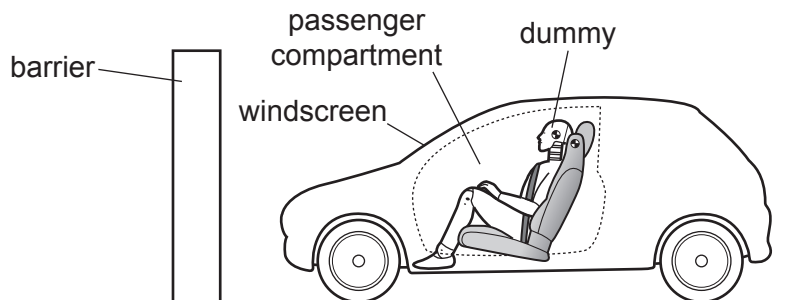

Fig. 2.1

The car approaches a solid barrier at 20 m/s. It crashes into the barrier and stops suddenly.

(a) (i) Calculate the momentum of the dummy immediately before the crash.

momentum = [2]

(ii) Determine the impulse that must be applied to the dummy to bring it to rest.

impulse = [1]

(b) In the crash test, the passenger compartment comes to rest in 0.20 s.

Calculate the deceleration of the passenger compartment.

deceleration = [2]

(c) The seat belt and air bag bring the dummy to rest so that it does not hit the windscreen. The dummy has an average deceleration of 80 m/s^2 .

Calculate the average resultant force applied to the dummy, of mass 70 kg.

force = [2]

(d) The deceleration of the dummy is less than the deceleration of the passenger compartment.

Explain why this is of benefit for the safety of a passenger.

.....
.....
.....
.....
.....
.....

[2]

[Total: 9]

2 Fig. 2.1 shows a hammer being used to drive a nail into a piece of wood.

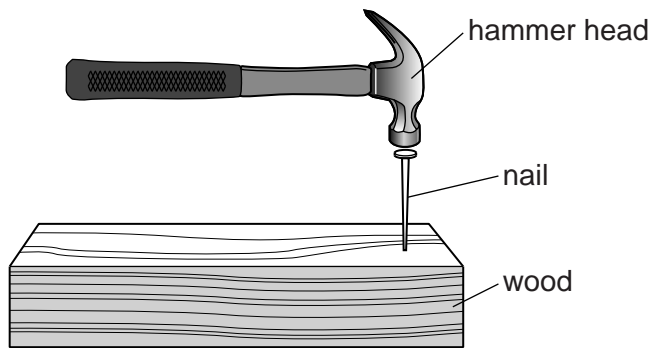

Fig. 2.1

The mass of the hammer head is 0.15 kg.

The speed of the hammer head when it hits the nail is 8.0 m/s.

The time for which the hammer head is in contact with the nail is 0.0015 s.

The hammer head stops after hitting the nail.

(a) Calculate the change in momentum of the hammer head.

change in momentum =[2]

(b) State the impulse given to the nail.

impulse =[1]

(c) Calculate the average force between the hammer and the nail.

average force =[2]

[Total: 5]

- 3 The engine of an unpowered toy train is rolling at a constant speed on a level track, as shown in Fig. 3.1. The engine collides with a stationary toy truck, and joins with it.

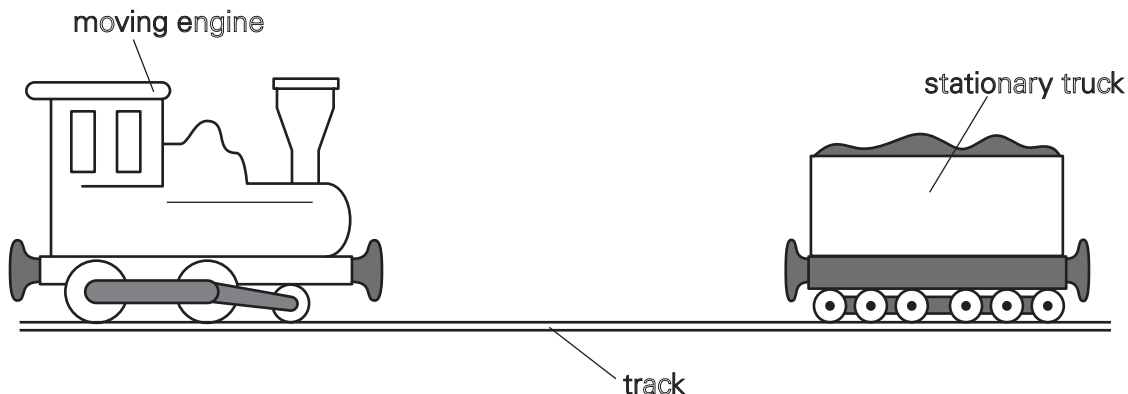

Fig. 3.1

Before the collision, the toy engine is travelling at 0.32 m/s. The mass of the engine is 0.50 kg.

- (a) Calculate the momentum of the toy engine before the collision.

momentum = [2]

- (b) The mass of the truck is 0.30 kg.

Using the principle of conservation of momentum, calculate the speed of the joined engine and truck immediately after the collision.

speed = [3]

[Total: 5]

- 4 Fig. 4.1 represents part of the hydraulic braking system of a car.

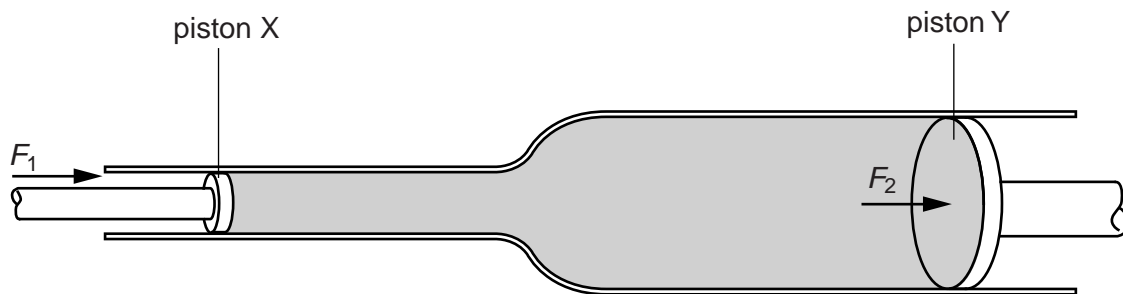

Fig. 4.1

The force F_1 of the driver's foot on the brake pedal moves piston X. The space between pistons X and Y is filled with oil which cannot be compressed. The force F_2 exerted by the oil moves piston Y. This force is applied to the brake mechanism in the wheels of the car.

The area of cross-section of piston X is 4.8cm^2 .

- (a) The force F_1 is 90N. Calculate the pressure exerted on the oil by piston X.

pressure = [2]

- (b) The pressure on piston Y is the same as the pressure applied by piston X. Explain why the force F_2 is greater than the force F_1 .

.....
 [1]

- (c) Piston Y moves a smaller distance than piston X. Explain why.

.....

 [2]

(d) Suggest why the braking system does not work properly if the oil contains bubbles of air.

.....
.....
..... [2]

[Total: 7]