

**Questions are for both separate science and combined science students unless indicated in the question**

**1.**

The figure below shows part of the National Grid linking a power station to consumers.

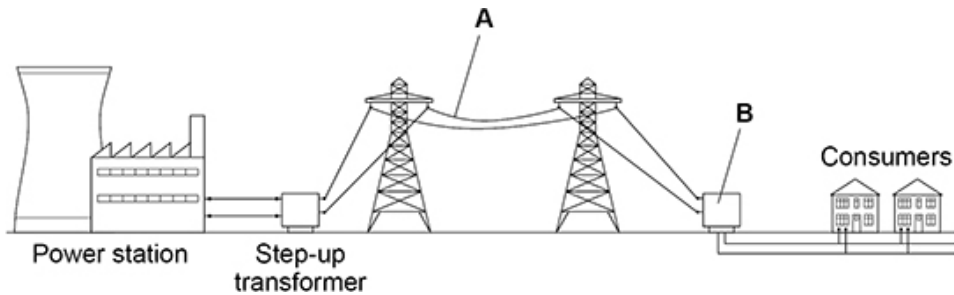

- (a) Name the parts of the figure above labelled **A** and **B**.

**A** \_\_\_\_\_

**B** \_\_\_\_\_

(2)

- (b) Electricity is transmitted through **A** at a very high potential difference.

What is the advantage of transmitting electricity at a very high potential difference?

Tick (✓) **one** box.

A high potential difference is safer for consumers.

Less thermal energy is transferred to the surroundings.

Power transmission is faster.

(1)

- (c) The power station generates electricity at a potential difference of 25 000 V.

The energy transferred by the power station in one second is 500 000 000 J.

Calculate the charge flow from the power station in one second.

Use the equation:

$$\text{charge flow} = \frac{\text{energy}}{\text{potential difference}}$$

---



---



---

Charge flow in one second = \_\_\_\_\_ C

(2)

The electricity supply to a house has a potential difference of 230 V.

The table below shows the current in some appliances in the house.

Appliance	Current in amps
Dishwasher	6.50
DVD player	0.10
Lamp	0.40
TV	0.20

- (d) Calculate the total power of all the appliances in the table above.

Use the equation:

$$\text{power} = \text{potential difference} \times \text{current}$$

---



---



---



---



---

Total power = \_\_\_\_\_ W

(3)

- (e) Each appliance in the table above is switched on for 2 hours.

Which appliance will transfer the most energy?

Give a reason for your answer.

Appliance \_\_\_\_\_

Reason \_\_\_\_\_

\_\_\_\_\_

\_\_\_\_\_

(2)

- (f) The average energy transferred from the National Grid every second for each person in the UK is 600 J.

There are 32 000 000 seconds in one year.

Calculate the average energy transferred each year from the National Grid for each person in the UK.

\_\_\_\_\_

\_\_\_\_\_

\_\_\_\_\_

Average energy transferred = \_\_\_\_\_ J

(2)

(Total 12 marks)

2.

The figure below shows a house with a solar power system.

The solar cells generate electricity.

When the electricity generated by the solar cells is not needed, the energy is stored in a large battery.

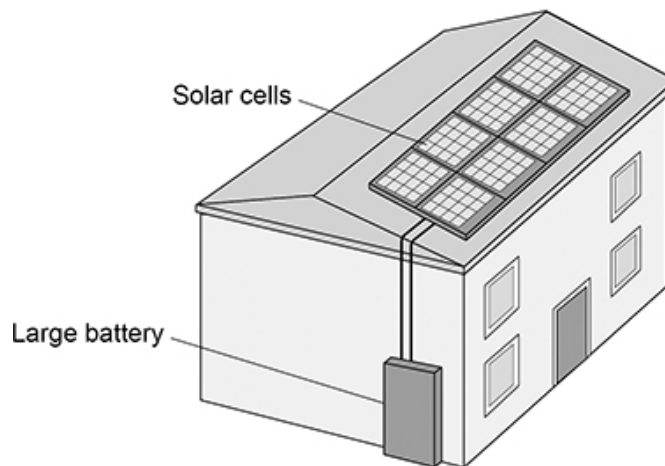

- (a) The solar cells on the roof of the house always face in the same direction.

Explain **one** disadvantage caused by the solar cells only facing in one direction.

---

---

---

---

(2)

- (b) The mean current from the solar cells to the battery is 3.5 A.

Calculate the charge flow from the solar cells to the battery in 3600 seconds.

Use the equation:

$$\text{charge flow} = \text{current} \times \text{time}$$

---

---

---

$$\text{Charge flow} = \text{_____ C}$$

(2)

- (c) Write down the equation which links efficiency, total power input and useful power output.

---

(1)

- (d) At one time in the day, the total power input to the solar cells was 7500 W.

The efficiency of the solar cells was 0.16

Calculate the useful power output of the solar cells.

---

---

---

---

$$\text{Useful power output} = \text{_____ W}$$

(3)

- (e) The wasted energy that is **not** usefully transferred by the solar cells is dissipated.

What happens to energy that has been dissipated?

Tick (✓) **one** box.

The energy becomes less useful.

The energy is destroyed.

The energy is used to generate electricity.

(1)

- (f) Why is it unlikely that all the UK's electricity needs could be met by solar power systems?

Tick (✓) **one** box.

A very large area would need to be covered with solar cells.

Solar power is a non-renewable energy resource.

The efficiency of solar cells is too high.

(1)

(Total 10 marks)

**3.**

A child drops a ball.

The ball hits the ground and bounces.

The graph below shows the velocity-time graph for the ball from when the ball is dropped until when the ball reaches the top of its first bounce.

Air resistance has been ignored.

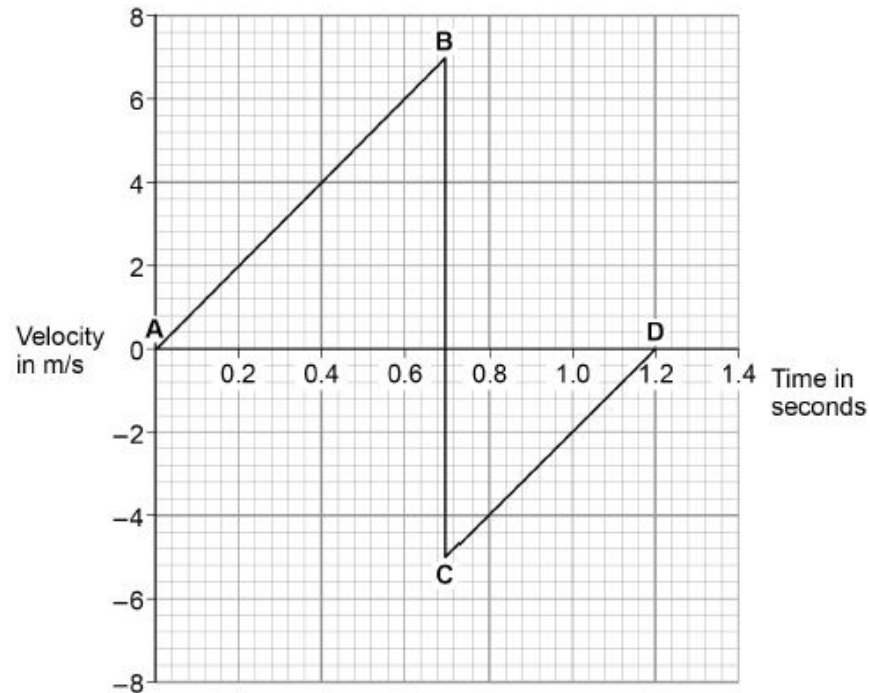

- (a) Describe the motion of the ball between points **A** and **B** on the graph above.

---

---

---

---

(2)

- (b) What direction is the ball moving between points **C** and **D** on the graph above?

---

(1)

(c) The ball and the Earth form a system.

What is meant by 'a system'?

Tick **one** box.

A group of objects that interact.

Objects with big differences in mass.

Objects with gravitational potential energy.

(1)

(d) When the ball hits the ground, energy is transferred from the ball to the Earth.

Explain how the data in the graph above shows this energy transfer.

---

---

---

---

---

---

---

---

---

---

---

(4)

(Total 8 marks)

4.

Figure 1 shows a hot water tank made of copper.

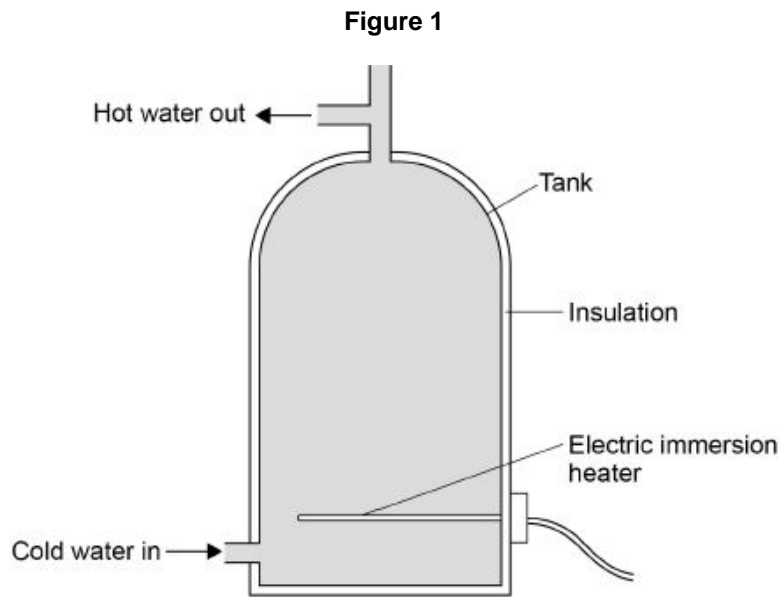

- (a) Copper has a higher thermal conductivity than most metals.

How does the rate of energy transfer through copper compare with the rate of energy transfer through most metals?

Tick **one** box.

Higher

Lower

The same

(1)

- (b) The tank is insulated. When the water is hot, the immersion heater switches off.

Complete the sentences.

Compared to a tank with no insulation, the rate of energy transfer from the water in an insulated tank is \_\_\_\_\_.

This means that the water in the insulated tank stays \_\_\_\_\_ for longer.

(2)



**Figure 2** shows how temperature varies with time for water in a tank heated with an immersion heater.

**Figure 3** shows how temperature varies with time for water in a tank heated with a solar panel.

**Figure 2**

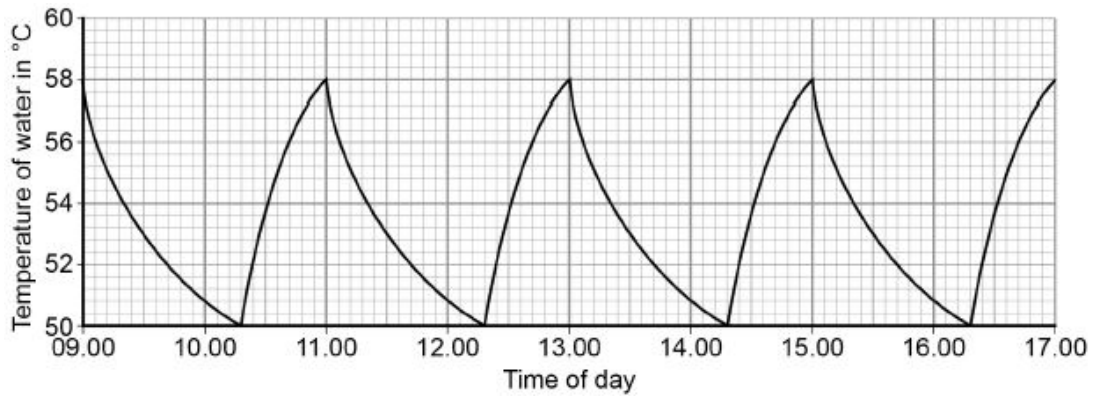

**Figure 3**

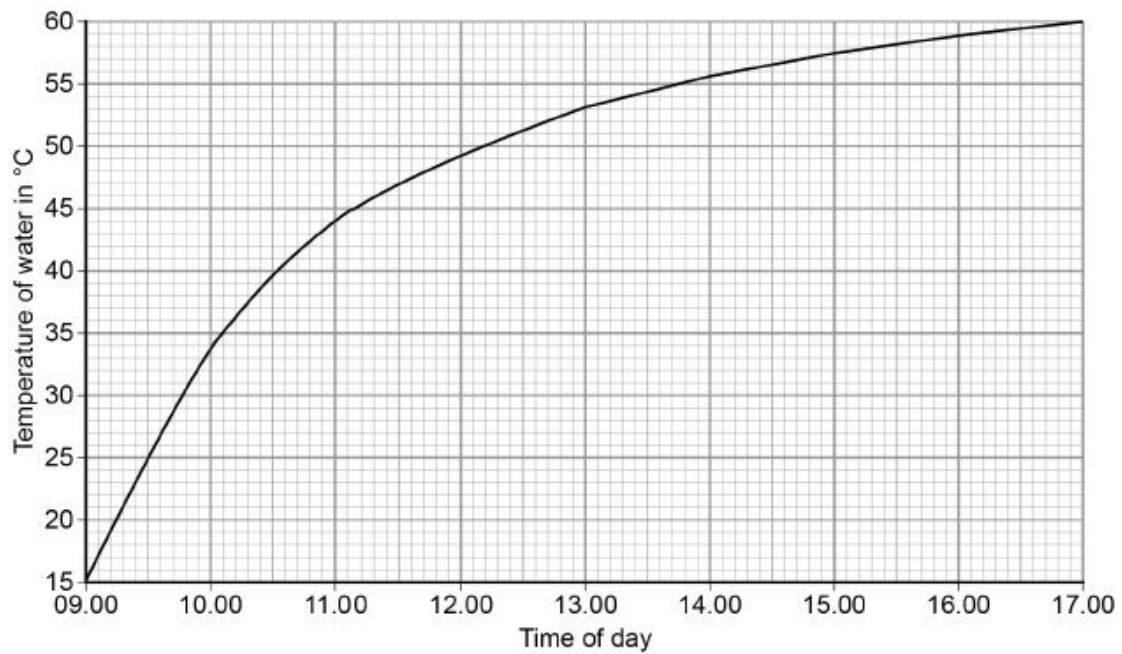

- (c) Give **one** advantage and **one** disadvantage of heating the water using solar panels rather than an immersion heater.

Use only information from **Figure 2** and **Figure 3**.

Advantage of solar panels \_\_\_\_\_

\_\_\_\_\_

\_\_\_\_\_

Disadvantage of solar panels \_\_\_\_\_

\_\_\_\_\_

\_\_\_\_\_

- (d) During one morning, a total of 4 070 000 J of energy is transferred from the electric immersion heater.

4 030 000 J of energy are transferred to the water.

Calculate the proportion of the total energy transferred to the water.

---

---

---

---

Proportion of total energy = \_\_\_\_\_

(2)

- (e) Write down the equation that links energy transferred, power and time.

---

(1)

- (f) The power output of the immersion heater is 5000 W.

Calculate the time taken for the immersion heater to transfer 4 070 000 J of energy.

Give the unit.

---

---

---

---

Time = \_\_\_\_\_ Unit \_\_\_\_\_

(4)

(Total 12 marks)

5.

The figure below shows a diver about to dive off a diving board.

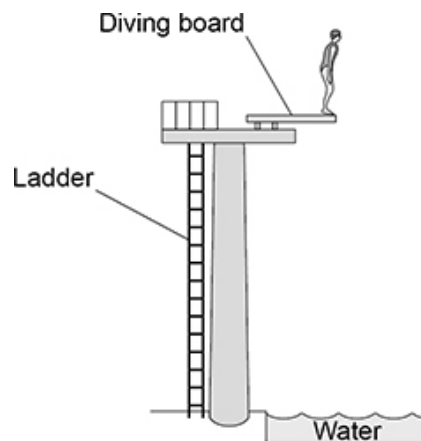

- (a) Complete the sentences.

Choose answers from the box.

<b>elastic potential</b>	<b>gravitational potential</b>	<b>kinetic</b>	<b>nuclear</b>
--------------------------	--------------------------------	----------------	----------------

As the diver falls towards the water there is a decrease in

her \_\_\_\_\_ energy.

As the diver falls towards the water there is an increase in

her \_\_\_\_\_ energy.

(2)

- (b) Write down the equation which links kinetic energy (
- $E_k$
- ), mass (
- $m$
- ) and speed (
- $v$
- ).

\_\_\_\_\_

(1)

- (c) At the instant the diver hits the water, the kinetic energy of the diver is 5040 J.

The speed of the diver is 12 m/s.

Calculate the mass of the diver.

\_\_\_\_\_

\_\_\_\_\_

\_\_\_\_\_

\_\_\_\_\_

Mass = \_\_\_\_\_ kg

(3)

- (d) Most of the kinetic energy of the diver is transferred to the water.

How does this affect the thermal energy of the water?

Tick (✓) **one** box.

The thermal energy decreases.

The thermal energy stays the same.

The thermal energy increases.

(1)

(Total 7 marks)

6.

The photograph below shows an electric car being recharged.



- (a) The charging station applies a direct potential difference across the battery of the car.

What does 'direct potential difference' mean?

---



---



---

(1)

- (b) Which equation links energy transferred ( $E$ ), power ( $P$ ) and time ( $t$ )?

Tick (✓) **one** box.

energy transferred =  $\frac{\text{power}}{\text{time}}$

energy transferred =  $\frac{\text{time}}{\text{power}}$

energy transferred = power  $\times$  time

energy transferred = power<sup>2</sup>  $\times$  time

(1)

- (c) The battery in the electric car can store 162 000 000 J of energy.

The charging station has a power output of 7200 W.

Calculate the time taken to fully recharge the battery from zero.

---



---



---



---



---

Time taken = \_\_\_\_\_ s

(3)

- (d) Which equation links current ( $I$ ), potential difference ( $V$ ) and resistance ( $R$ )?

Tick (✓) **one** box.

$I = V \times R$

$I = V^2 \times R$

$R = I \times V$

$V = I \times R$

(1)

- (e) The potential difference across the battery is 480 V.

There is a current of 15 A in the circuit connecting the battery to the motor of the electric car.

Calculate the resistance of the motor.

---



---



---



---



---

Resistance = \_\_\_\_\_  $\Omega$

(3)

(f) Different charging systems use different electrical currents.

- Charging system **A** has a current of 13 A.
- Charging system **B** has a current of 26 A.
- The potential difference of both charging systems is 230 V.

How does the time taken to recharge a battery using charging system **A** compare with the time taken using charging system **B**?

Tick (✓) **one** box.

Time taken using system **A** is half the time of system **B**

Time taken using system **A** is the same as system **B**

Time taken using system **A** is double the time of system **B**

(1)

(Total 10 marks)

7.

Energy from the Sun is released by nuclear fusion.

(a) Complete the sentences. **(separate only)**

Nuclear fusion is the joining together of \_\_\_\_\_.

During nuclear fusion the total mass of the particles \_\_\_\_\_.

(2)

(b) Nuclear fusion of deuterium is difficult to achieve on Earth because of the high temperature needed.

Electricity is used to increase the temperature of 4.0 g of deuterium by 50 000 000 °C.

specific heat capacity of deuterium = 5200 J/kg °C

Calculate the energy needed to increase the temperature of the deuterium by 50 000 000 °C.

Use the Physics Equations Sheet.

---



---



---



---



---

Energy = \_\_\_\_\_ J

(3)

- (c) The idea of obtaining power from nuclear fusion was investigated using models.

The models were tested before starting to build the first commercial nuclear fusion power station.

Suggest **two** reasons why models were tested.

1 \_\_\_\_\_

\_\_\_\_\_

\_\_\_\_\_

2 \_\_\_\_\_

\_\_\_\_\_

\_\_\_\_\_

(2)

- (d) Generating electricity using nuclear fusion will have fewer environmental effects than generating electricity using fossil fuels.

Explain **one** environmental effect of generating electricity using fossil fuels.

\_\_\_\_\_

\_\_\_\_\_

\_\_\_\_\_

\_\_\_\_\_

\_\_\_\_\_

(2)

(Total 9 marks)

**8.** The thinking distance and braking distance for a car vary with the speed of the car.

- (a) Explain the effect of **two** other factors on the **braking** distance of a car.

Do **not** refer to speed in your answer.

\_\_\_\_\_

\_\_\_\_\_

\_\_\_\_\_

\_\_\_\_\_

\_\_\_\_\_

\_\_\_\_\_

\_\_\_\_\_

\_\_\_\_\_

\_\_\_\_\_

\_\_\_\_\_

(4)

(b) Which equation links acceleration ( $a$ ), mass ( $m$ ) and resultant force ( $F$ ).

Tick (✓) **one** box.

resultant force = mass  $\times$  acceleration

resultant force = mass  $\times$  acceleration<sup>2</sup>

resultant force =  $\frac{\text{mass}}{\text{acceleration}^2}$

resultant force =  $\frac{\text{mass}}{\text{acceleration}}$

(1)

(c) The mean braking force on a car is 7200 N.

The car has a mass of 1600 kg.

Calculate the deceleration of the car.

---

---

---

---

---

Deceleration = \_\_\_\_\_ m/s<sup>2</sup>

(3)



- (d) **Figure 1** below shows how the thinking distance and braking distance for a car vary with the speed of the car.

**Figure 1**

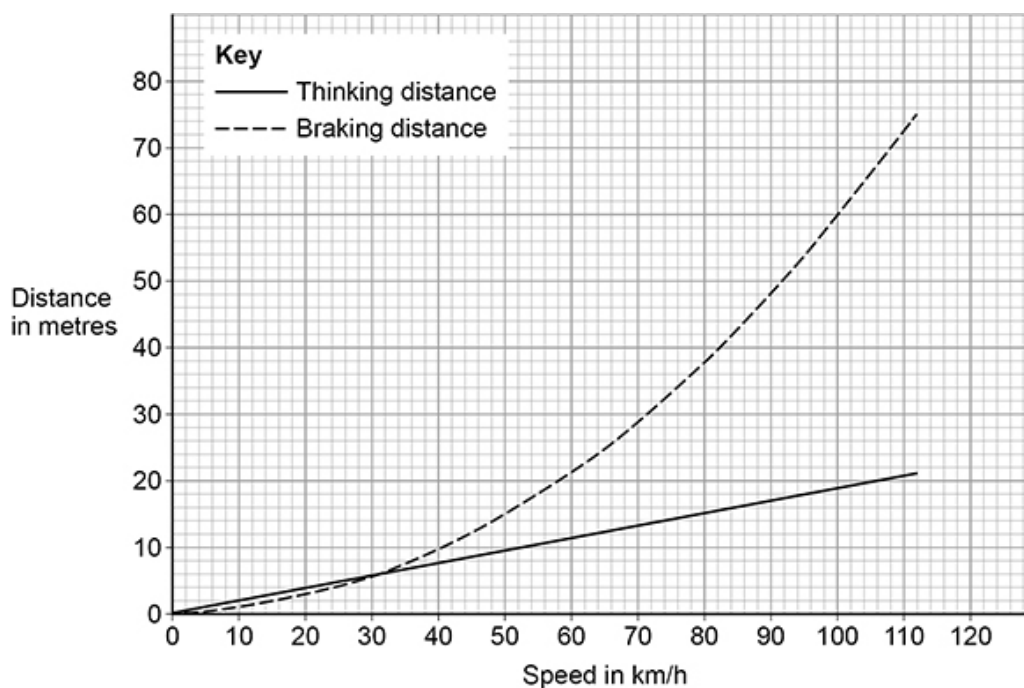

Determine the stopping distance when the car is travelling at 80 km/h.

---



---



---

Stopping distance = \_\_\_\_\_ m

(2)

**Figure 2** below shows part of the braking system for a car.

**Figure 2**

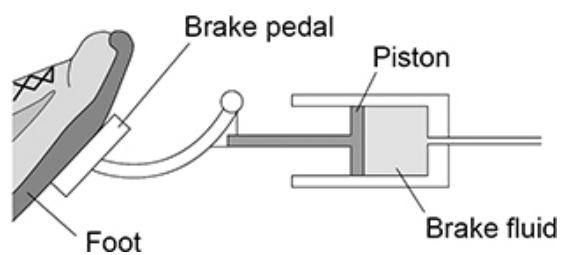

- (e) Which equation links area of a surface ( $A$ ), the force normal to that surface ( $F$ ) and pressure ( $p$ )?

Tick (✓) **one** box.

$$p = F \times A$$

$$p = F \times A^2$$

$$p = \frac{F}{A}$$

$$p = \frac{A}{F}$$

(1)

- (f) When the brake pedal is pressed, a force of 60 N is applied to the piston.

The pressure in the brake fluid is 120 000 Pa.

Calculate the surface area of the piston.

Give your answer in standard form.

Give the unit.

---

---

---

---

---

---

---

---

---

---

Surface area (in standard form) = \_\_\_\_\_ Unit \_\_\_\_\_

(5)

(Total 16 marks)

9.

The photograph below shows a theme park ride called AquaShute.

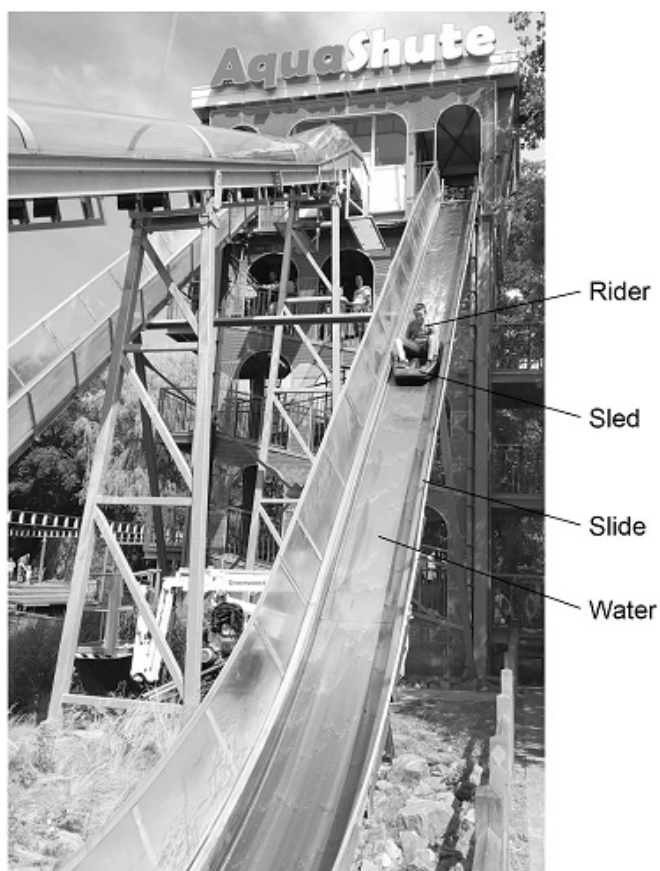

(a) Riders of the AquaShute sit on a sled and move down a slide.

There is a layer of water between the sled and the slide.

How does the layer of water affect the friction between the sled and the slide?

Tick (✓) **one** box.

The friction is decreased.

The friction is increased.

The friction is not affected.

(1)

- (b) The mass of one rider is 62.5 kg.

The height of the slide is 16.0 m.

gravitational field strength = 9.8 N/kg

Calculate the gravitational potential energy of the rider at the top of the slide.

Use the equation:

$$\text{gravitational potential energy} = \text{mass} \times \text{gravitational field strength} \times \text{height}$$

---



---



---



---

$$\text{Gravitational potential energy} = \text{_____ J}$$

(2)

- (c) At the bottom of the slide the speed of the rider is 12 m/s.

The mass of the rider is 62.5 kg.

Calculate the kinetic energy of the rider at the bottom of the slide.

Use the equation:

$$\text{kinetic energy} = 0.5 \times \text{mass} \times (\text{speed})^2$$

---



---



---



---

$$\text{Kinetic energy} = \text{_____ J}$$

(2)

- (d) When a rider reaches the bottom of the slide, the sled decelerates and stops.

Give **two** factors that will affect how far the sled will move before it stops.

1 \_\_\_\_\_

---

2 \_\_\_\_\_

---

(2)

(Total 7 marks)

10.

The diagram below shows a hydroelectric power station.

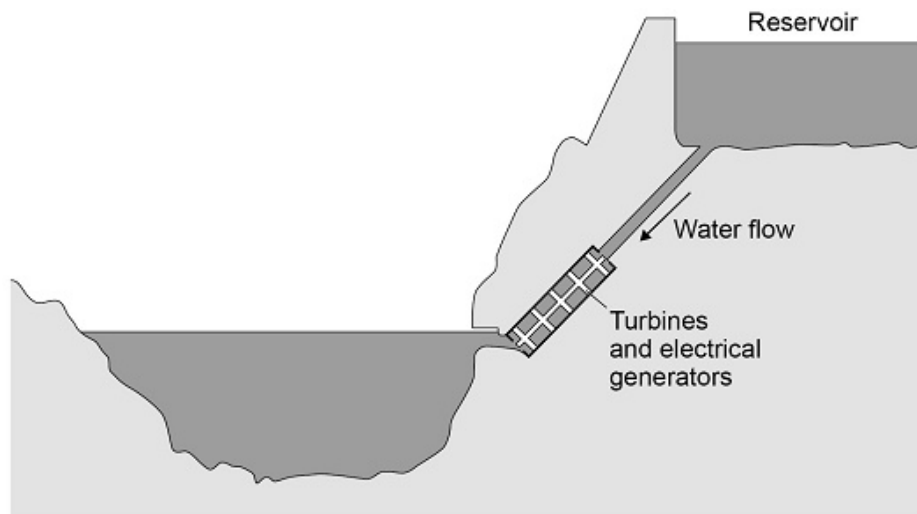

Electricity is generated when water from the reservoir flows through the turbines.

- (a) Write down the equation which links density ( $\rho$ ), mass ( $m$ ) and volume ( $V$ ).

---

(1)

- (b) The reservoir stores 6 500 000 m<sup>3</sup> of water.

The density of the water is 998 kg/m<sup>3</sup>.

Calculate the mass of water in the reservoir.

Give your answer in standard form.

---



---



---



---



---

Mass (in standard form) = \_\_\_\_\_ kg

(4)

- (c) Write down the equation which links energy transferred ( $E$ ), power ( $P$ ) and time ( $t$ ).

---

(1)

- (d) The electrical generators can provide  $1.5 \times 10^9$  W of power for a maximum of 5 hours.

Calculate the maximum energy that can be transferred by the electrical generators.

---



---



---



---



---

Energy transferred = \_\_\_\_\_ J

(3)

- (e) The graph below shows how the UK demand for electricity increases and decreases during one day.

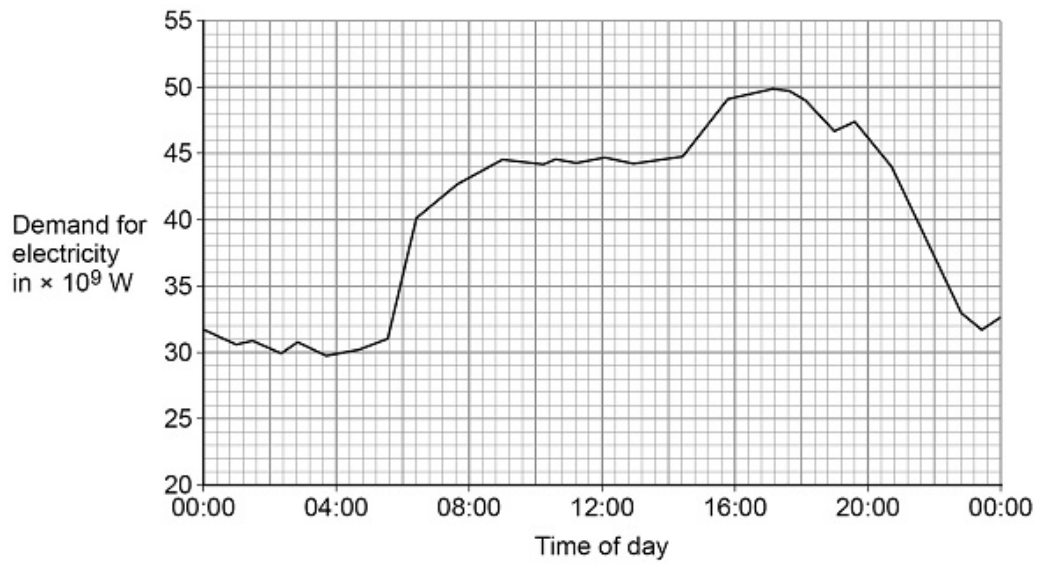

The hydroelectric power station in the above diagram can provide  $1.5 \times 10^9$  W of power for a maximum of 5 hours.

Give **two** reasons why this hydroelectric power station is not able to meet the increase in demand shown between 04:00 and 16:00 in above graph.

1 \_\_\_\_\_

\_\_\_\_\_

\_\_\_\_\_

2 \_\_\_\_\_

\_\_\_\_\_

\_\_\_\_\_

(2)

(Total 11 marks)

11.

The diagram below shows how the National Grid connects power stations to consumers.

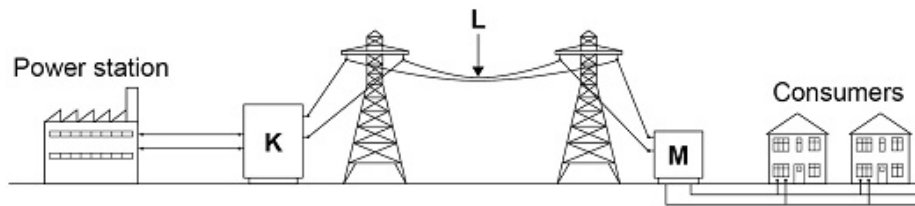

(a) Name the parts of the National Grid labelled K, L and M.

K = \_\_\_\_\_

L = \_\_\_\_\_

M = \_\_\_\_\_

(3)

**Figure 1** shows how the percentage of electricity generated by gas-fired power stations changed in the UK over 5 years.

**Figure 1**

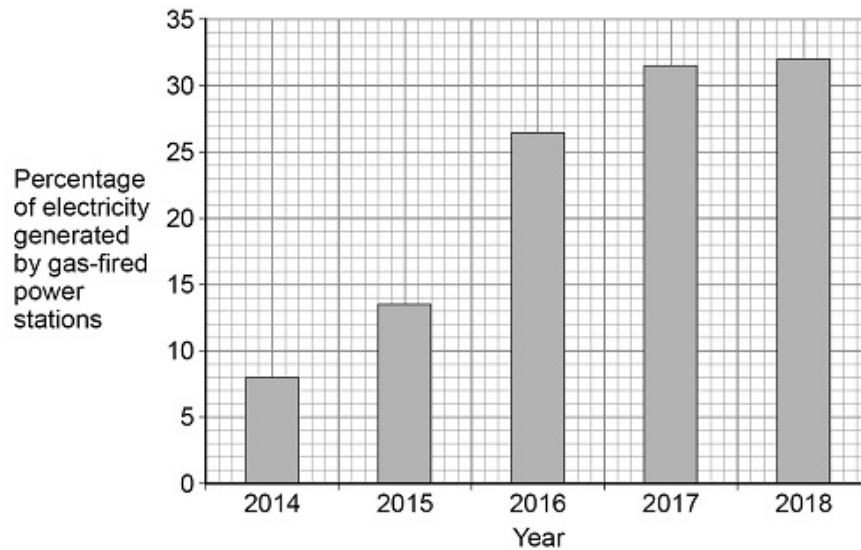

(b) Calculate how many times greater the percentage of electricity generated by gas-fired power stations was in 2018 than in 2014.

\_\_\_\_\_

\_\_\_\_\_

\_\_\_\_\_

Number of times greater = \_\_\_\_\_

(2)

- (c) Explain **one** environmental effect of generating electricity using a gas-fired power station.

---

---

---

---

(2)

- (d) The UK government wants more electricity to be generated using renewable energy resources.

What is a renewable energy resource?

Tick (✓) **one** box.

An energy resource that can be burned

An energy resource that can be recycled

An energy resource that can be replenished quickly

An energy resource that can be reused

(1)



- (e) An offshore wind farm is a group of wind turbines that are placed out at sea.

**Figure 2** shows the power output of an offshore wind farm compared with a wind farm on land for a 24-hour period.

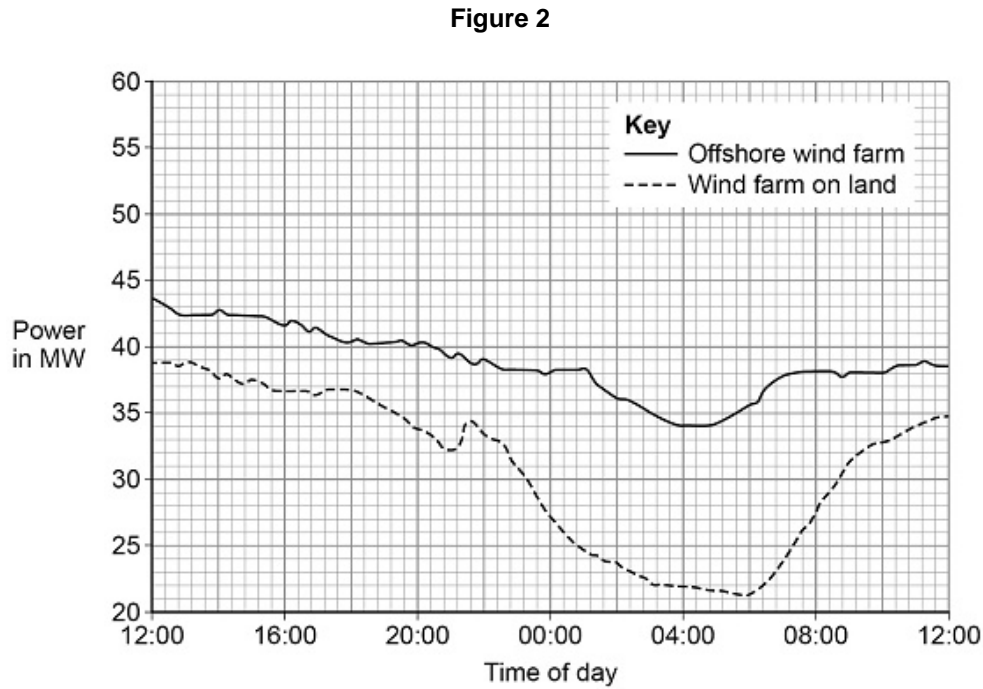

Give **two** advantages of the offshore wind farm compared with the wind farm on land.

Use information from **Figure 2**.

1 \_\_\_\_\_

\_\_\_\_\_

2 \_\_\_\_\_

\_\_\_\_\_

(2)

(Total 10 marks)

**12.**

A student heated water in an electric kettle.

- (a) Water has a high specific heat capacity.

Complete the sentence.

Choose answers from the box.

$^{\circ}\text{C}$	J	kg	s	W
--------------------	---	----	---	---

The specific heat capacity of a substance is the energy needed to raise the temperature of 1 \_\_\_\_\_ of the substance by 1 \_\_\_\_\_.

(2)

- (b) The kettle circuit contains a thermistor which is used to switch the kettle off when the water reaches 100 °C.

What is the correct symbol for a thermistor?

Tick (✓) **one** box.

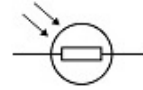
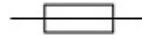
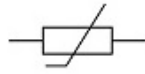

(1)

(c) The resistance of the heating element in the kettle is  $15 \Omega$ .

The current in the heating element is  $12 \text{ A}$ .

Calculate the power of the heating element.

Use the equation:

$$\text{power} = (\text{current})^2 \times \text{resistance}$$

---

---

---

---

---

Power = \_\_\_\_\_ W

(2)

The student investigated how quickly the kettle could increase the temperature of  $0.50 \text{ kg}$  of water.

The graph below shows the results of the investigation.

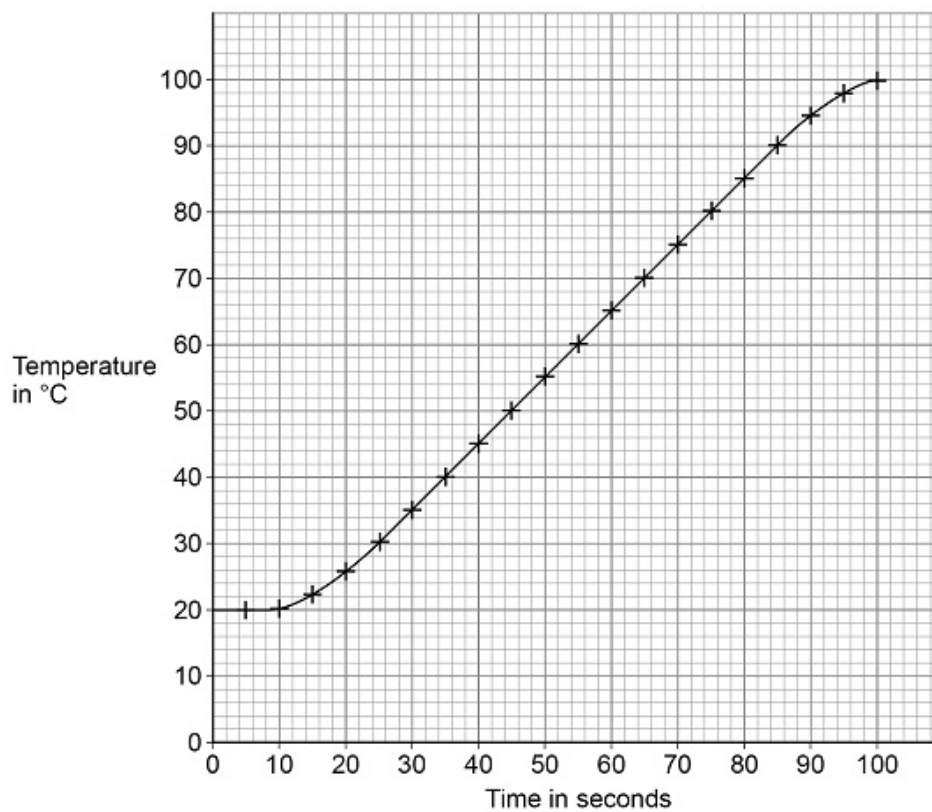



- (f) The mass of water in the kettle was 0.50 kg.

The temperature of the water increased from 20 °C to 100 °C.

specific heat capacity of water = 4200 J/kg/°C

Calculate the energy transferred to the water.

Use the Physics Equations Sheet.

---

---

---

---

---

Energy = \_\_\_\_\_ J

**(3)**

- (g) The water in the kettle boiled for a short time before the kettle switched off.

During this time 5.0 g of water changed to steam.

specific latent heat of vaporisation of water = 2 260 000 J/kg

Calculate the energy transferred to change the water to steam.

Use the Physics Equations Sheet.

---

---

---

---

---

Energy = \_\_\_\_\_ J

**(3)**

**(Total 18 marks)**

13.

The following figure shows a person sliding down a zip wire.

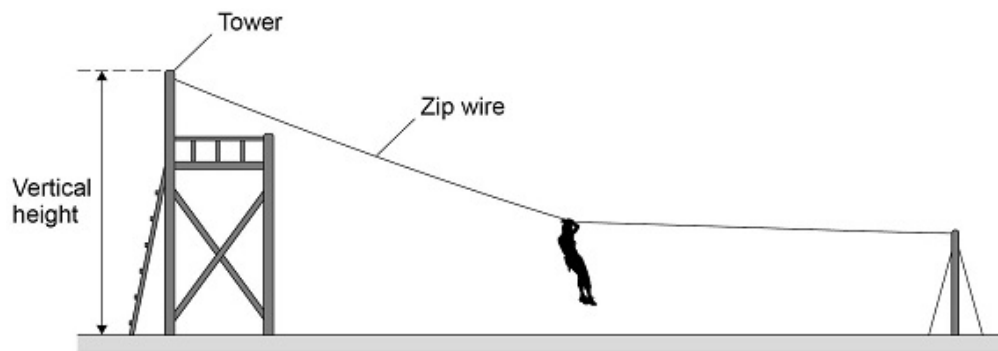

- (a) Describe how the vertical height of the tower could be measured accurately.

---



---



---



---

(2)

- (b) When using the zip wire, the person moved through a vertical height of 2.0 m

The person has a mass of 45 kg

gravitational field strength = 9.8 N/kg

Calculate the change in gravitational potential energy of the person.

Use the equation:

$$\text{gravitational potential energy} = \text{mass} \times \text{gravitational field strength} \times \text{height}$$

---



---



---



---

Change in gravitational potential energy = \_\_\_\_\_ J

(2)

- (c) Give **three** factors that affected the kinetic energy of the person as she reached the bottom of the zip wire.

1 \_\_\_\_\_  
 \_\_\_\_\_  
 2 \_\_\_\_\_  
 \_\_\_\_\_  
 3 \_\_\_\_\_  
 \_\_\_\_\_

(3)  
 (Total 7 marks)

14.

The photograph below shows an LED torch.



- (a) The torch contains one LED, one switch and three cells.

Which diagram shows the correct circuit for the torch?

Tick (✓) **one** box.

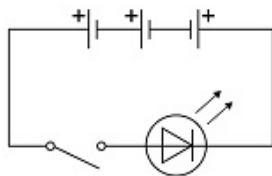

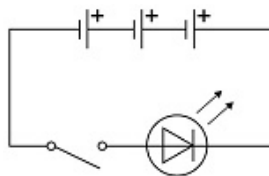

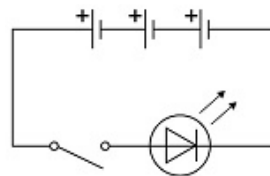

(1)

- (b) Write down the equation which links charge flow ( $Q$ ), current ( $I$ ) and time ( $t$ ).

---

(1)

- (c) The torch worked for 14 400 seconds before the cells needed replacing.

The current in the LED was 50 mA.

Calculate the total charge flow through the cells.

---

---

---

---

Total charge flow = \_\_\_\_\_ C

**(3)**

- (d) When replaced, the cells were put into the torch the wrong way around.

Explain why the torch did not work.

---

---

---

---

---

---

**(2)**

- (e) Write down the equation which links efficiency, total power input and useful power output.

---

---

**(1)**

- (f) The total power input to the LED was 0.24 W.

The efficiency of the LED was 0.75

Calculate the useful power output of the LED.

---

---

---

---

Useful power output = \_\_\_\_\_ W

**(3)**

**(Total 11 marks)**



15.

**Figure 1** shows how different energy resources were used in the United Kingdom (UK) to generate electricity on one day in June 2018.

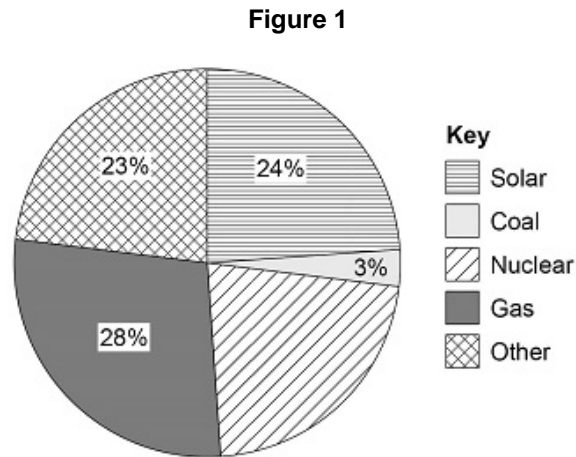

- (a) The UK government plans to stop using coal-fired power stations by 2025.

Explain **one** environmental problem caused when electricity is generated by burning coal.

---



---



---



---



---

(2)

- (b) Give **two** renewable energy resources that could make up the 'Other' energy resources in **Figure 1**.

1 \_\_\_\_\_

---

2 \_\_\_\_\_

---

(2)

- (c) Determine the percentage of electricity generated in nuclear power stations that day.

Use data from **Figure 1**.

---



---



---

Percentage of electricity generated in nuclear power stations = \_\_\_\_\_%

(2)

Figure 2 shows how the demand for electricity varied with the time of day.

Figure 2

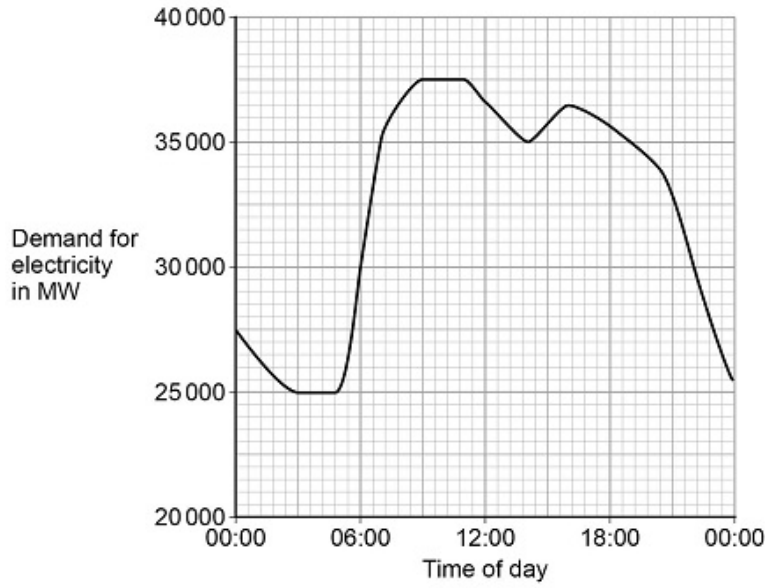

- (d) What was the difference between the maximum demand and minimum demand for electricity during this day?

---



---



---



---

Difference = \_\_\_\_\_ MW

(2)

- (e) Figure 2 shows that the demand for electricity increased between 06:00 and 09:00

Solar power could have met the demand if there were enough solar panels installed in the UK.

Explain why.

---



---



---



---

(2)

(Total 10 marks)

16.

An electric car has a motor that is powered by a battery.

A diesel car has an engine that is powered by diesel fuel.

(a) The table compares an electric car and a diesel car.

Power source	Maximum acceleration in $\text{m/s}^2$	Mass of power source in kg	Range in km	Maximum power output in kW
Battery	4.8	420	220	200
Diesel fuel	3.2	51	1120	120

Give **two** advantages of the diesel car compared with the electric car in the table.

1 \_\_\_\_\_

\_\_\_\_\_

2 \_\_\_\_\_

\_\_\_\_\_

(2)

(b) The mass of the battery in the electric car is 420 kg

The total mass of the electric car is 1610 kg

Calculate the mass of the battery as a percentage of the total mass of the electric car.

\_\_\_\_\_

\_\_\_\_\_

\_\_\_\_\_

\_\_\_\_\_

Percentage of total mass = \_\_\_\_\_%

(2)

(c) Designers of electric car batteries want to increase the amount of energy that can be stored in a battery.

Suggest **two** reasons why.

1 \_\_\_\_\_

\_\_\_\_\_

2 \_\_\_\_\_

\_\_\_\_\_

(2)

The figure below shows an electric car being recharged.

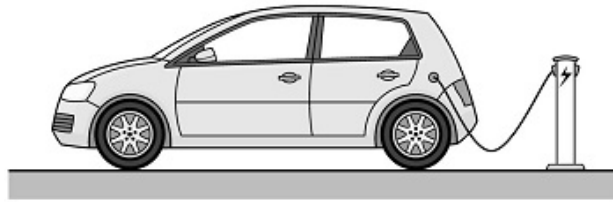

- (d) Write down the equation which links energy transferred, power and time.

---

---

(1)

- (e) The charger has a power output of 7000 W

Calculate the time taken to transfer 420 000 J of energy to the car battery.

---

---

---

---

Time = \_\_\_\_\_ s

(3)

(Total 10 marks)

17.

A student carried out an experiment to determine the specific heat capacity of water.

**Figure 1** shows the equipment the student used to heat the water.

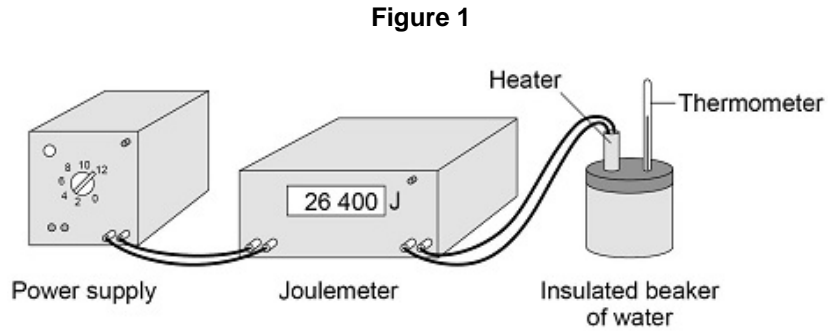

(a) Why did the student insulate the beaker of water?

Tick (✓) **one** box.

To increase energy transfer to the surroundings.

To reduce energy transfer to the surroundings.

To stop energy transfer to the surroundings.

(1)

(b) One hazard in this experiment is the hot water.

Give **one** risk to the student caused by this hazard.

---



---

(1)

- (c) **Figure 2** shows the thermometer that the student used.

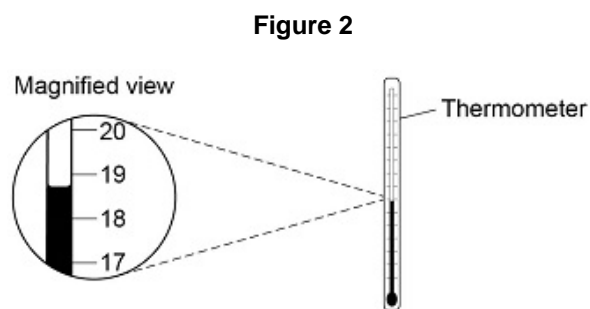

What is the resolution of the thermometer?

Tick (✓) **one** box.

1 °C

3 °C

19 °C

(1)

- (d) **Figure 3** shows the beaker of water on a balance.

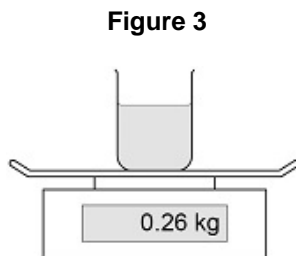

The mass of the water was 0.20 kg

What was the mass of the beaker?

Tick (✓) **one** box.

0.06 kg

0.20 kg

0.26 kg

0.46 kg

(1)

(e) The energy transferred to the water was 26 400 J

The mass of water was 0.20 kg

The temperature increase of the water was 30 °C

Calculate the specific heat capacity of water using the data from this experiment.

Use the Physics Equations Sheet.

Choose the unit from the box.

<b>J/kg</b>	<b>J/kg°C</b>	<b>J/°C</b>
-------------	---------------	-------------

---



---



---



---



---

Specific heat capacity = \_\_\_\_\_ Unit \_\_\_\_\_

(4)

(Total 8 marks)

**18.**

Light bulbs are labelled with a power input.

(a) What does power input mean?

Tick (✓) **one** box.

The charge transferred each second by the bulb.

The current through the bulb.

The energy transferred each second to the bulb.

The potential difference across the bulb.

(1)

(b) Write down the equation which links current, potential difference and power.

---

(1)

- (c) A light bulb has a power input of 40 W  
The mains potential difference is 230 V

Calculate the current in the light bulb.

---



---



---

Current = \_\_\_\_\_ A

(3)

The following table shows information about three different light bulbs.

Light bulb	Total power input in watts	Useful power output in watts	Efficiency
P	6.0	5.4	0.90
Q	40	2.0	0.05
R	9.0	X	0.30

- (d) Write down the equation which links efficiency, total power input and useful power output.

---

(1)

- (e) Calculate the value of X in the table above.

---



---



---



---

X = \_\_\_\_\_ W

(3)

- (f) In addition to power input, light bulbs should also be labelled with the rate at which they emit visible light.

Suggest why.

---



---



---



---

(2)

(Total 11 marks)



19.

A scientist investigated how the maximum muscle power of humans varies with age and gender.

The scientist asked volunteers to stand on a platform and to jump as high as they could.

**Figure 1** shows a volunteer taking part in the experiment.

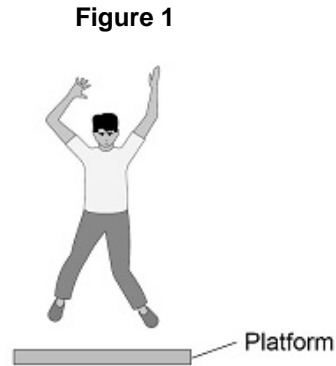

An electronic timer measured the time that the volunteer was in the air.

(a) The muscle power in watts per kg is calculated using the following equation:

$$\text{muscle power} = \frac{9.8 \times \text{jump height}}{\text{time}}$$

One volunteer has a muscle power of 41 W/kg

He was in the air for 0.12 s

Calculate his jump height.

---



---



---



---

Jump height = \_\_\_\_\_ m

**(3)**

(b) Write down the equation which links kinetic energy, mass and speed.

---

**(1)**

- (c) One volunteer had a kinetic energy of 270 J and a speed of 3.0 m/s at the moment he left the ground.

Calculate his mass.

---

---

---

---

---

Mass = \_\_\_\_\_ kg

**(3)**

Figure 2 shows the scientist's results.

Figure 2

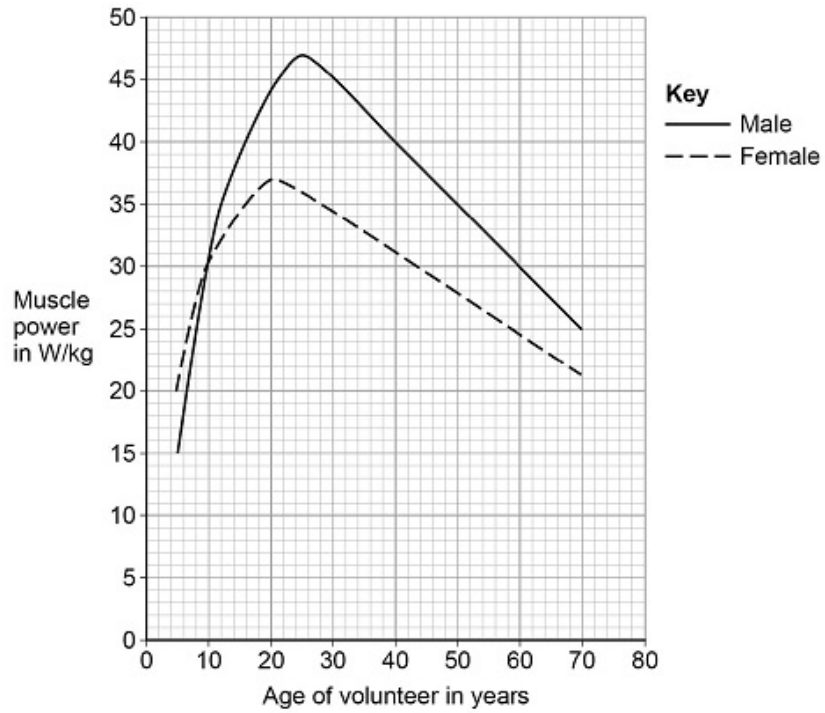

- (d) Compare the muscle power of males with the muscle power of females.

Use data from **Figure 2** in your answer.

---

---

---

---

---

---

---

---

---

---

---

---

---

---

---

(e) The muscle power of each volunteer was measured five times.

The highest muscle power reading was recorded instead of calculating an average.

Suggest **one** reason why.

---

---

---

---

(1)

(Total 12 marks)

20.

A student investigated the insulating properties of newspaper.

**Figure 1** shows the apparatus the student used.

**Figure 1**

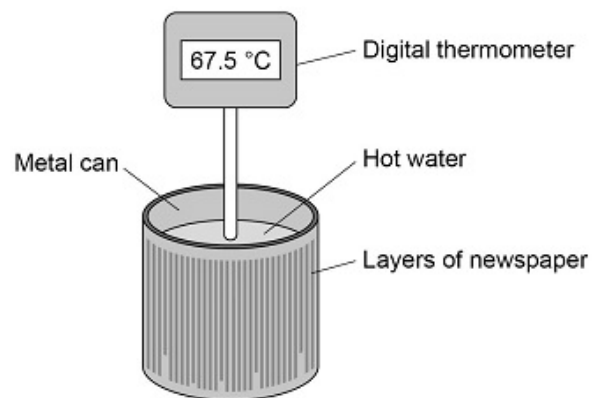

The student's results are shown in **Figure 2**.

**Figure 2**

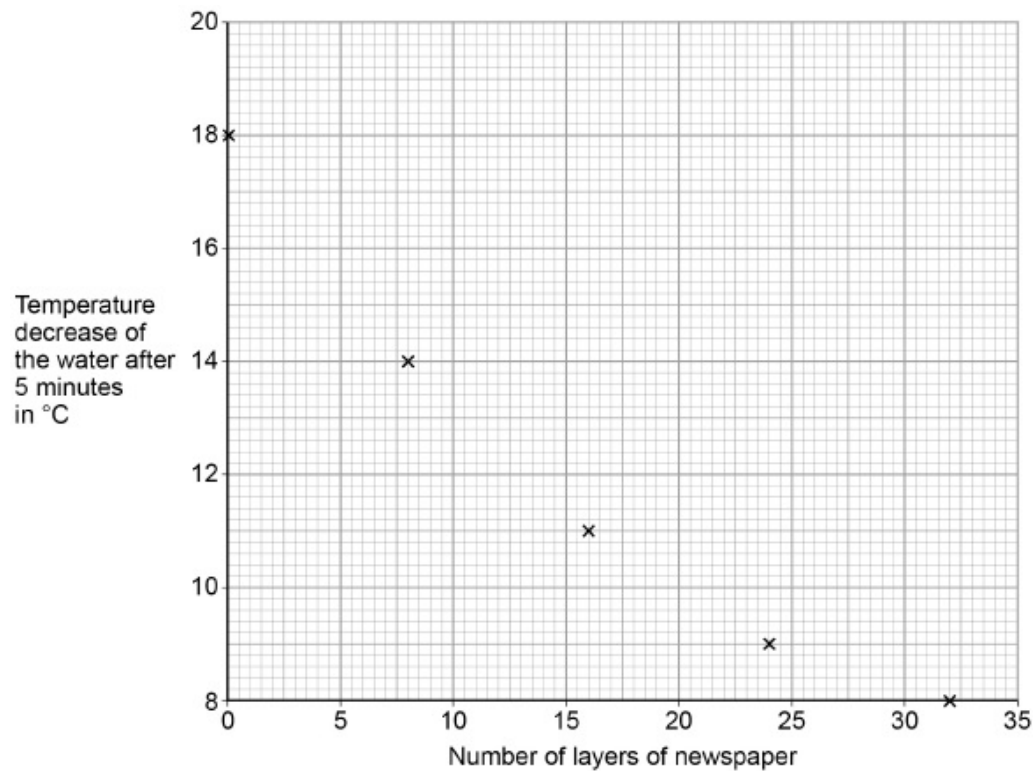

- (a) Describe a method the student could have used to obtain the results shown in **Figure 2**.

---



---



---



---



---



---



---



---



---



---



---



---



---



---



---



---

- (b) The student could have used a datalogger with a temperature probe instead of the digital thermometer.

**Figure 3** shows the readings on the digital thermometer and the datalogger.

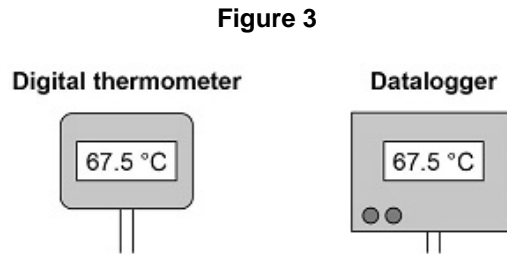

The datalogger records 10 readings every second.

The student considered using a temperature probe and datalogger.

Explain why it was **not** necessary to use a temperature probe and datalogger for this investigation.

---



---



---



---



---



---

(2)

(Total 8 marks)

**21.**

The diagram below shows a cyclist riding along a flat road.



- (a) Complete the sentence.

Choose answers from the box.

<b>chemical</b>	<b>elastic potential</b>	<b>gravitational potential</b>	<b>kinetic</b>
-----------------	--------------------------	--------------------------------	----------------

As the cyclist accelerates, the \_\_\_\_\_ energy store in the cyclist's body decreases and the \_\_\_\_\_ energy of the cyclist increases.

(2)

- (b) The mass of the cyclist is 80 kg. The speed of the cyclist is 12 m/s.

Calculate the kinetic energy of the cyclist.

Use the equation:

$$\text{kinetic energy} = 0.5 \times \text{mass} \times (\text{speed})^2$$

---

---

---

---

$$\text{Kinetic energy} = \text{_____} \text{ J}$$

(2)

- (c) When the cyclist uses the brakes, the bicycle slows down.

This causes the temperature of the brake pads to increase by 50 °C.

The mass of the brake pads is 0.040 kg.

The specific heat capacity of the material of the brake pads is 480 J/kg °C.

Calculate the change in thermal energy of the brake pads.

Use the equation:

$$\text{change in thermal energy} = \text{mass} \times \text{specific heat capacity} \times \text{temperature change}$$

---

---

---

$$\text{Change in thermal energy} = \text{_____} \text{ J}$$

(2)

- (d) How is the internal energy of the particles in the brake pads affected by the increase in temperature?

Tick **one** box.

Decreased

Increased

Not affected

(1)

(Total 7 marks)

22.

Nuclear power can be used to generate electricity through nuclear fission.

Figure 1 shows the process of nuclear fission.

Figure 1

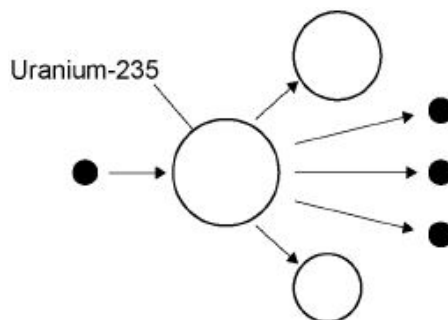

(a) Complete the sentences.

Choose answers from the box. (separate only)

gamma rays	light rays	proton	neutron	nucleus	X-rays
------------	------------	--------	---------	---------	--------

During the process of nuclear fission, a uranium \_\_\_\_\_

absorbs a \_\_\_\_\_ .

Electromagnetic radiation is released in the form of \_\_\_\_\_ .

(3)

(b) The UK needs at least 25 000 000 kW of electrical power at any time.

A nuclear power station has an electrical power output of 2 400 000 kW

Calculate how many nuclear power stations are needed to provide 25 000 000 kW of electrical power.

---



---



---



---

Number of nuclear power stations = \_\_\_\_\_

(2)

(c) State **two** environmental issues caused by generating electricity using nuclear power stations.

1. \_\_\_\_\_

---

2. \_\_\_\_\_

---

(2)



- (d) The UK currently generates a lot of electricity by burning natural gas. This process releases carbon dioxide into the atmosphere.

**Figure 2** shows how the concentration of carbon dioxide in the atmosphere has changed over the past 115 years.

**Figure 2**

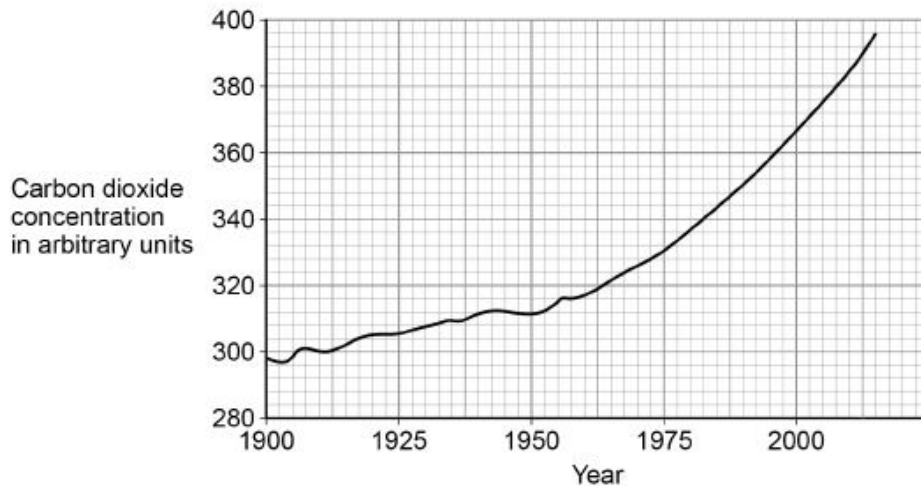

**Figure 3** shows how the global temperature has changed over the past 115 years.

**Figure 3**

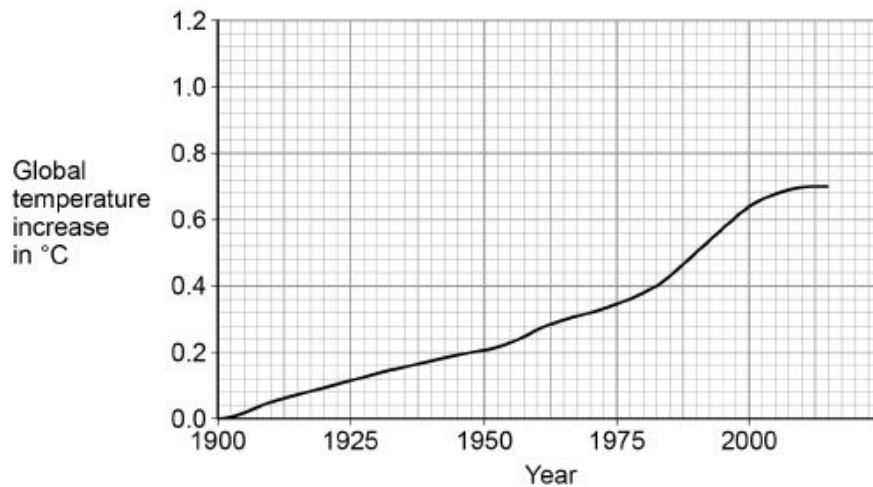

Give **one** similarity and **one** difference between the data in **Figure 2** and **Figure 3**.

Similarity \_\_\_\_\_

\_\_\_\_\_

\_\_\_\_\_

Difference \_\_\_\_\_

\_\_\_\_\_

\_\_\_\_\_

(2)

(Total 9 marks)

**23.****Figure 1** shows a lift inside a building.**Figure 1**

- (a) The motor in the lift does 120 000 J of work in 8.0 seconds.

Calculate the power output of the motor in the lift.

Use the equation:

$$\text{Power output} = \frac{\text{work done}}{\text{time}}$$

---

---

---

---

Power output = \_\_\_\_\_ W

(2)

- (b) The power input to the motor is greater than the power output.

Tick **two** reasons why.

Energy is transferred in heating the surroundings.

Friction causes energy to be transferred in non-useful ways.

The motor is connected to the mains electricity supply.

The motor is more than 100% efficient.

There are only four people in the lift.

(2)

- (c) **Figure 2** shows part of the circuit that operates the lift motor.

**Figure 2**

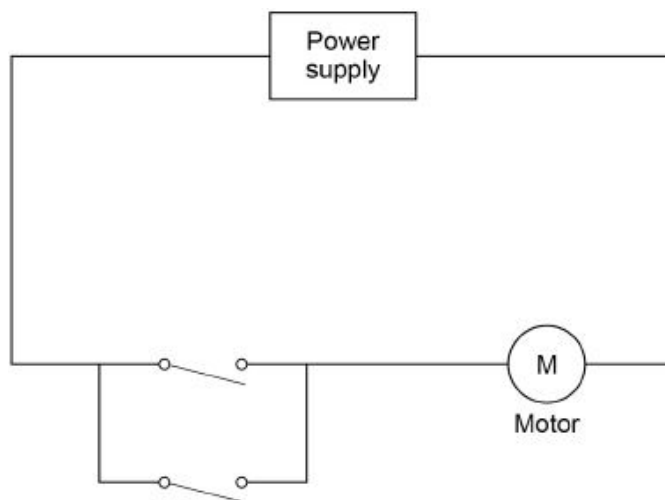

The lift can be operated using either of the two switches.

Explain why.

---



---



---



---



---

(2)

- (d) Write down the equation that links gravitational field strength, gravitational potential energy, height and mass.

---



---

(1)

- (e) The lift goes up 14 m. The total mass of the people in the lift is 280 kg.

gravitational field strength = 9.8 N/kg

Calculate the increase in gravitational potential energy of the people in the lift.

Give your answer to 2 significant figures.

---



---



---



---

Increase in gravitational potential energy = \_\_\_\_\_ J

(3)

(Total 10 marks)

**24.**

The National Grid ensures that the supply of electricity always meets the demand of the consumers.

The figure below shows how the output from fossil fuel power stations in the UK varied over a 24-hour period.

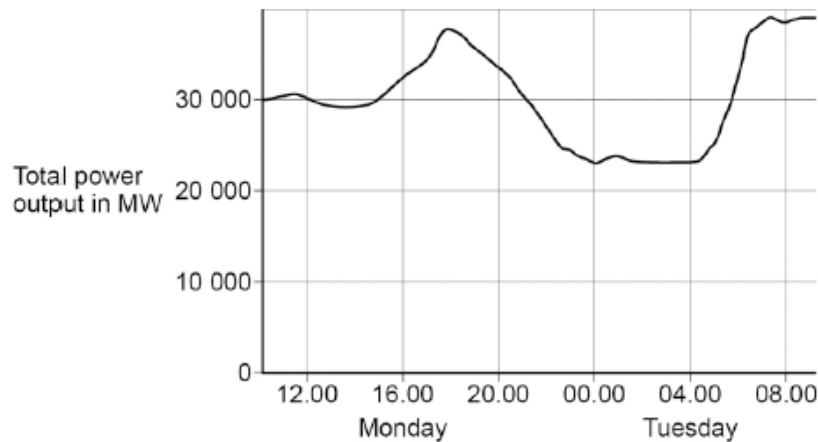

- (a) Suggest **one** reason for the shape of the graph between 15.00 and 18.00 on Monday.

---



---

(1)

- (b) Gas fired power stations reduce their output when demand for electricity is low.

Suggest **one** time on the figure above when the demand for electricity was low.

---



---

(1)

- (c) The National Grid ensures that fossil fuel power stations in the UK only produce about 33% of the total electricity they could produce when operating at a maximum output.

Suggest **two** reasons why.

1. \_\_\_\_\_

---

2. \_\_\_\_\_

---

(2)

(Total 4 marks)

**25.**

A student investigated how much energy from the Sun was incident on the Earth's surface at her location.

She put an insulated pan of water in direct sunlight and measured the time it took for the temperature of the water to increase by  $0.6\text{ }^{\circ}\text{C}$ .

The apparatus she used is shown in the figure below.

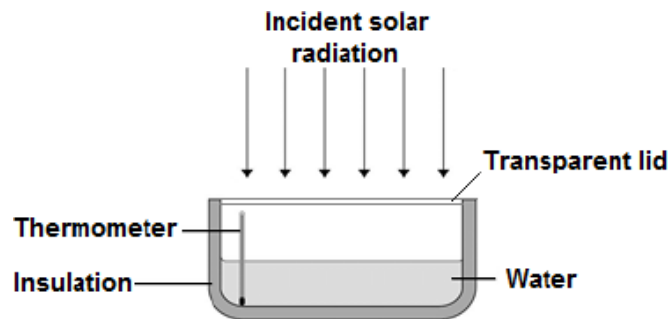

- (a) Choose the most appropriate resolution for the thermometer used by the student.

Tick **one** box.

0.1  $^{\circ}\text{C}$

0.5  $^{\circ}\text{C}$

1.0  $^{\circ}\text{C}$

(1)

- (b) The energy transferred to the water was 1050 J.

The time taken for the water temperature to increase by 0.6 °C was 5 minutes.

The specific heat capacity of water is 4200 J / kg °C.

Write down the equation which links energy transferred, power and time.

---

(1)

- (c) Calculate the mean power supplied by the Sun to the water in the pan.

---

---

---

Average power = \_\_\_\_\_ W

(2)

- (d) Calculate the mass of water the student used in her investigation.

Use the correct equation from the Physics Equation Sheet.

---

---

---

Mass = \_\_\_\_\_ kg

(3)

- (e) The student's results can only be used as an estimate of the mean power at her location.

Give **one** reason why.

---

---

(1)

(Total 8 marks)