



F

Thursday 19 June 2014 – Afternoon

GCSE GATEWAY SCIENCE PHYSICS B

B752/01 Physics modules P4, P5, P6 (Foundation Tier)

Candidates answer on the Question Paper.
A calculator may be used for this paper.

OCR supplied materials:
None

Other materials required:

- Pencil
- Ruler (cm/mm)

Duration: 1 hour 30 minutes

Candidate forename		Candidate surname	
-----------------------	--	----------------------	--

Centre number						Candidate number				
---------------	--	--	--	--	--	------------------	--	--	--	--

INSTRUCTIONS TO CANDIDATES

- Write your name, centre number and candidate number in the boxes above. Please write clearly and in capital letters.
- Use black ink. HB pencil may be used for graphs and diagrams only.
- Answer **all** the questions.
- Read each question carefully. Make sure you know what you have to do before starting your answer.
- Write your answer to each question in the space provided. Additional paper may be used if necessary but you must clearly show your candidate number, centre number and question number(s).
- Do **not** write in the bar codes.

INFORMATION FOR CANDIDATES

- The quality of written communication is assessed in questions marked with a pencil (✎).
- A list of equations can be found on page 2.
- The number of marks is given in brackets [] at the end of each question or part question.
- The total number of marks for this paper is **85**.
- This document consists of **28** pages. Any blank pages are indicated.

2

EQUATIONS

$$\text{energy} = \text{mass} \times \text{specific heat capacity} \times \text{temperature change}$$

$$\text{energy} = \text{mass} \times \text{specific latent heat}$$

$$\text{efficiency} = \frac{\text{useful energy output} (\times 100\%)}{\text{total energy input}}$$

$$\text{wave speed} = \text{frequency} \times \text{wavelength}$$

$$\text{power} = \text{voltage} \times \text{current}$$

$$\text{energy supplied} = \text{power} \times \text{time}$$

$$\text{average speed} = \frac{\text{distance}}{\text{time}}$$

$$\text{distance} = \text{average speed} \times \text{time}$$

$$s = \frac{(u + v)}{2} \times t$$

$$\text{acceleration} = \frac{\text{change in speed}}{\text{time taken}}$$

$$\text{force} = \text{mass} \times \text{acceleration}$$

$$\text{weight} = \text{mass} \times \text{gravitational field strength}$$

$$\text{work done} = \text{force} \times \text{distance}$$

$$\text{power} = \frac{\text{work done}}{\text{time}}$$

$$\text{power} = \text{force} \times \text{speed}$$

$$\text{KE} = \frac{1}{2}mv^2$$

$$\text{momentum} = \text{mass} \times \text{velocity}$$

$$\text{force} = \frac{\text{change in momentum}}{\text{time}}$$

$$\text{GPE} = mgh$$

$$\text{resistance} = \frac{\text{voltage}}{\text{current}}$$

$$v = u + at$$

$$v^2 = u^2 + 2as$$

$$s = ut + \frac{1}{2}at^2$$

$$m_1u_1 + m_2u_2 = (m_1 + m_2)v$$

$$\text{refractive index} = \frac{\text{speed of light in vacuum}}{\text{speed of light in medium}}$$

$$\text{magnification} = \frac{\text{image size}}{\text{object size}}$$

$$l_e = l_b + l_c$$

$$\frac{\text{voltage across primary coil}}{\text{voltage across secondary coil}} =$$

$$\frac{\text{number of primary turns}}{\text{number of secondary turns}}$$

$$\text{power loss} = (\text{current})^2 \times \text{resistance}$$

$$V_p I_p = V_s I_s$$

Answer **all** the questions.

SECTION A – Module P4

1 Ultrasound is a longitudinal wave.

(a) Look at the diagram of a longitudinal wave.

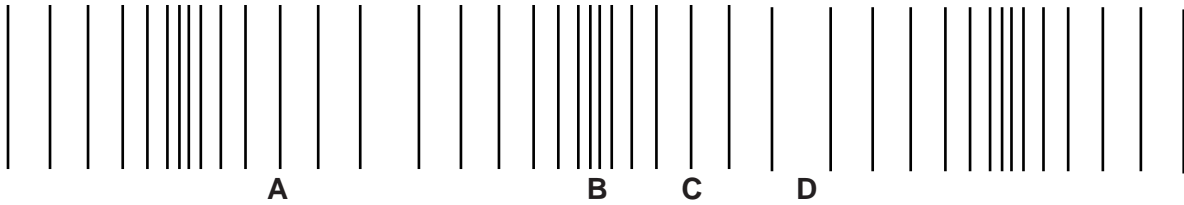

(i) Which letter **best** shows a compression?

Choose from

A B C D

answer [1]

(ii) Write down the name of the distance between **A** and **C**.

..... [1]

(b) The frequency of an ultrasound wave is 25 000 Hz.

Can humans hear this ultrasound?

.....

Explain your answer.

.....
.....
.....

[2]

(c) Ultrasound is used to 'look inside' a patient by scanning their body.

Write down **two** reasons why ultrasound scans may be used before operating on a patient.

.....
.....
.....

[2]

[Total: 6]

Turn over

4

2 Sheree does an experiment in her science lesson.

Look at a diagram of the circuit she uses.

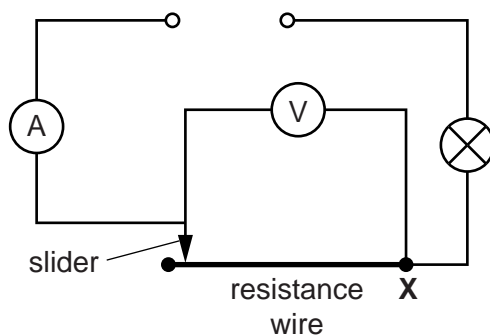

Sheree moves the slider to different positions along the resistance wire towards connection X.

This changes the length of the resistance wire in the circuit.

She writes down the readings from the ammeter and the voltmeter.

Look at Sheree's results.

Distance between slider and X in cm	Current in amps	Voltage in volts	Resistance in ohms
40	0.12	0.75	6.25
30	0.15	0.70	4.67
20	0.20	0.60
10	0.30	0.45

5

Calculate the missing values for resistance.

Use the information from the table to describe how current and resistance change when the length of the resistance wire is changed.



The quality of written communication will be assessed in your answer to this question.

.....

.....

.....

.....

.....

.....

.....

.....

.....

.....

.....

..... [6]

[Total: 6]

Question 3 begins on page 6

6

3 This question is about natural and artificial background radiation.

(a) Ben finds information on the internet about **natural** background radiation in different countries.

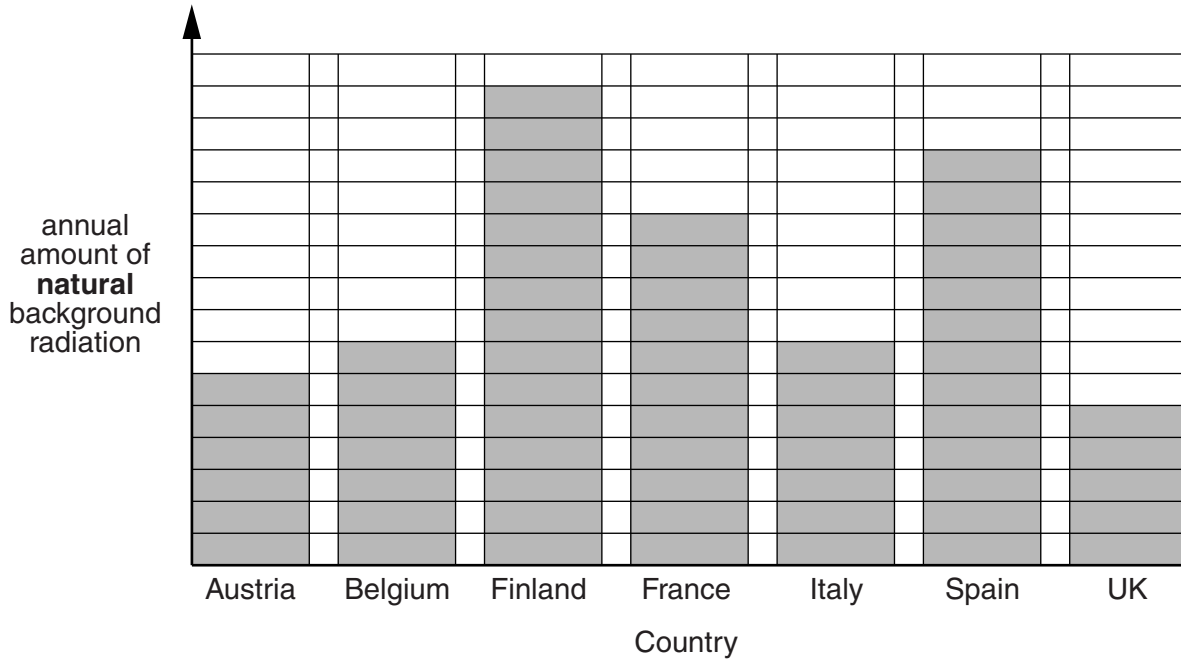

(i) What does the data show about the **natural** background radiation in different countries?
 [1]

(ii) Suggest why Finland has a high annual amount of **natural** background radiation.
 [1]

(b) Some **artificial** background radiation comes from industry.

Write down one use of radioactive **tracers** in industry.

..... [1]

[Total: 3]

7

BLANK PAGE

Question 4 begins on page 8

PLEASE DO NOT WRITE ON THIS PAGE

8

4 Medical radioisotopes use radioactive elements.

Radioactivity is measured by the number of nuclear decays per second.

Look at the graph showing the radioactive decay of element **A**.

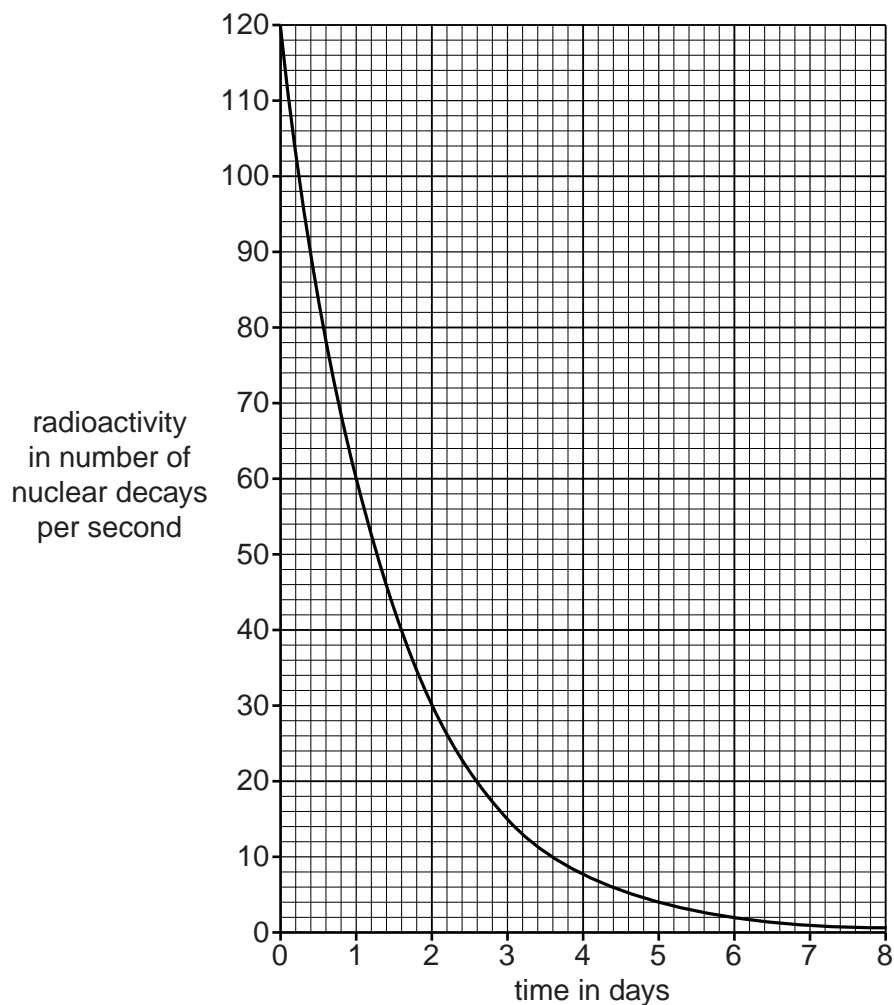

(a) (i) What happens to the radioactivity of element **A** between day 1 and day 2?

.....
 [2]

(ii) Doctor Hanif compares radioactive element **A** with radioactive element **B**.

Both elements start with the same radioactivity of 120 nuclear decays per second.

Element **B** has a **longer** half-life.

Draw a line on the graph to show the decay of element **B**.

[1]

9

(b) Doctor Hanif uses element **A** in the hospital where he works.

(i) The patient swallows a liquid containing a small amount of radioactive element **A**.

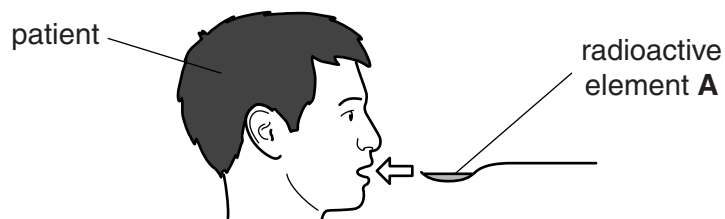

It is important to use a small amount of a radioactive element that decays quickly.

What is the risk of using a radioactive element with a **longer** half-life?

..... [1]

(ii) The amount of radioactivity near the patient's throat is measured.

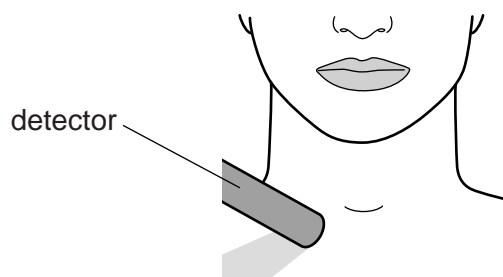

What type(s) of radiation can pass through the skin to the detector?

Choose from

alpha only

alpha and beta

beta only

beta and gamma

gamma only

answer [1]

[Total: 5]

5 Electrostatics can be useful or a nuisance.

(a) Electrostatics can be useful for spray painting.

The way that different paint guns work can be described using diagrams and models.

Diagram of a normal paint gun

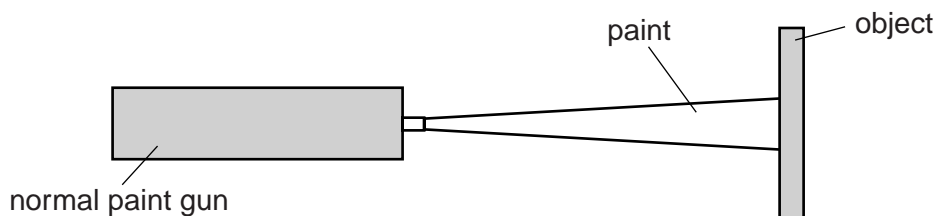
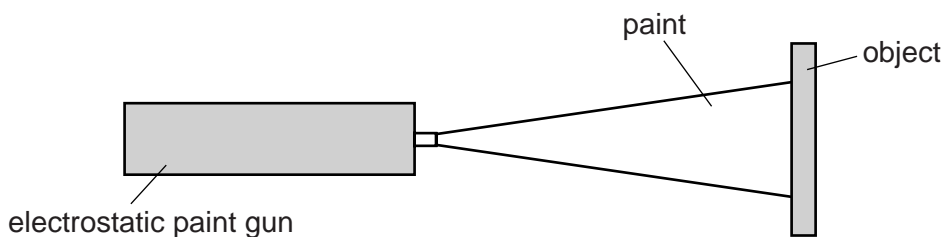

Diagram of an electrostatic paint gun



Use the diagrams to describe how and why the two paint guns work in different ways.

You may add more labels to the diagrams to help your description.

.....

.....

.....

.....

..... [3]

(b) Electrostatic shocks can be a nuisance.

Describe how you can get electrostatic shocks.

.....

.....

..... [2]

[Total: 5]

SECTION B – Module P5

6 Artificial satellites, such as TV Satellites, can be used for communication.

They are put into orbit around the Earth.

(a) TV satellites are in a high orbit above the equator **and** move around the Earth once every 24 hours.

Explain how this orbit is an **advantage** for satellite TV.

.....
.....
.....
..... [2]

(b) TV satellites use short wavelength radio waves (microwaves) to receive and send signals.

Explain why these waves have to be used rather than long wavelength radio waves.

.....
.....
.....
..... [2]

(c) Some weather forecasting satellites have lower orbits than TV satellites.

How does this **lower** orbit affect the time they take to move around the Earth?

..... [1]

(d) Satellites are taken into space by manned and unmanned rockets.

Rocket flight and space travel can be risky. However, the use of satellites can bring benefits.

Write about the risks and benefits of putting satellites into space.

.....
.....
.....
..... [3]

[Total: 8]

Turn over

12

7 Alex drives her car.

(a) Alex wants to overtake the lorry in front of her.

She needs to accelerate to overtake the lorry in front.

As she overtakes the lorry, Alex accelerates steadily from 13 m/s to 27 m/s in a time of 6 s.

Calculate the distance travelled as she overtakes.

.....

.....

.....

.....

distance travelled m [2]

(b) Alex now drives her car on a road which has a speed limit of 27 m/s.

She starts from rest at some traffic lights.

The car steadily accelerates at 3 m/s^2 for 10 seconds.

Calculate the car's final speed to see if she goes faster than the speed limit.

.....

.....

.....

Final speed m/s

Does she go faster than the 27 m/s speed limit?

.....

[2]

[Total: 4]

8 Sam wants to measure the focal length of some convex (converging) lenses.

He has some equipment.

- A metre rule measuring in cm
- A small ruler measuring in mm
- A sheet of white card
- A tree outside which he can use as a distant object
- 5 lenses of different thicknesses.

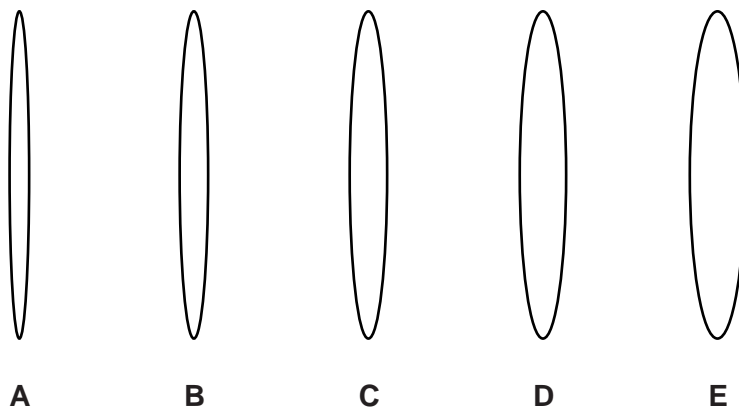

Explain what is meant by focal length and describe an experiment that Sam could do to investigate how the thickness of a lens affects its focal length.



The quality of written communication will be assessed in your answer to this question.

..... [6]

[Total: 6]

9 Jia makes a model air rocket in school.

She measures the maximum height and the range of flight for different launch angles.

Look at the diagram.

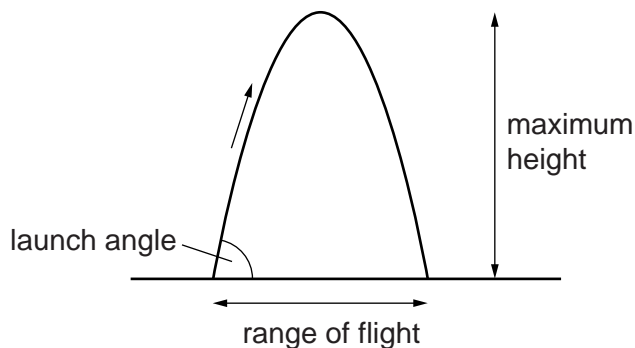

Look at Jia's results.

Launch angle in degrees	Maximum height reached in m	Range of flight in m
30	1.2	8.7
45	2.5	10.0
60	3.7	8.7
75	4.7	5.0

(a) Use the data to describe how the launch angle affects the range of flight of the rocket.

.....

 [2]

(b) Jia tests one more launch angle.

This angle gives the rocket its greatest maximum height.

Suggest the launch angle she used in this test.

..... degrees [1]

(c) Jia's rocket is a projectile and it follows a path.

If there is very little air resistance, the projectile path is very predictable.

(i) Name the **shape** of the path followed by Jia's rocket.

..... [1]

(ii) How does the force of gravity affect the vertical velocity **and** vertical acceleration as the rocket rises?

.....
.....
..... [2]

(iii) How does the force of gravity affect the horizontal velocity of the rocket?

.....
..... [1]

[Total: 7]

Question 10 begins on page 16

SECTION C – Module P6

10 Symbols are used to represent electronic components.

(a) Look at the two different symbols.



These electronic components are different types of resistors.

Write down the name of each electronic component **and** what makes their resistance change.

A

.....

B

.....

[3]

(b) Diodes allow a current to pass in only one direction.

Look at the circuit diagram.

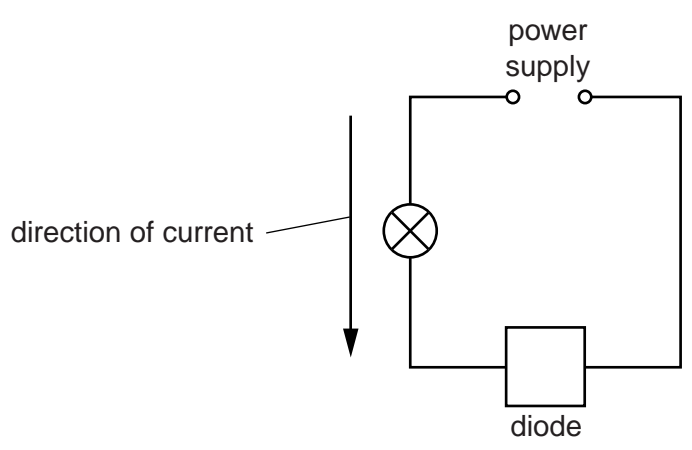

In the box labelled diode, draw a diode symbol which allows the current to pass in the direction shown. **[2]**

[Total: 5]

11 This question is about transformers.

Look at the information about two different transformers.

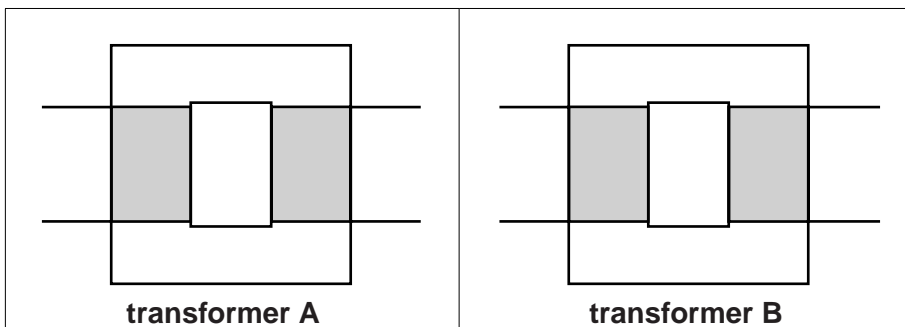

Type of core	iron	iron
Number of primary turns	500	1000
Number of secondary turns	1000	500
Input voltage	20 volts AC	20 volts AC

Write about the similarities and differences between transformer A and transformer B.

Include information about their construction, output voltage and uses.



The quality of written communication will be assessed in your answer to this question.

.....

.....

.....

.....

.....

.....

.....

.....

.....

.....

..... [6]

[Total: 6]

12 Many electronic devices contain logic gates.

(a) One type of logic gate is a NOT gate.

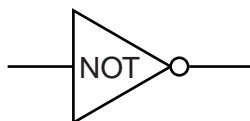

Complete the truth table for a NOT gate.

Input	Output
	0

[1]

(b) Logic gates can be combined together.

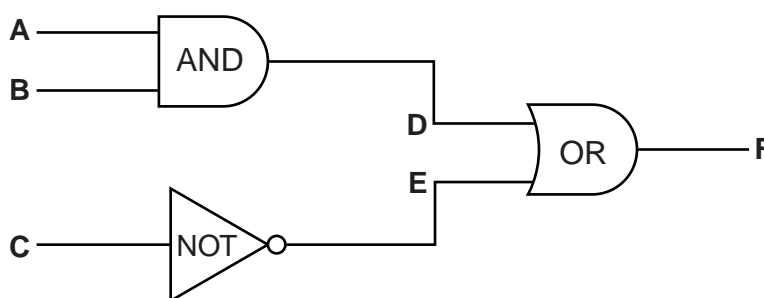

(i) Which letters represent **input** signals to the **AND** gate?

Choose from

- A and B** **A and C** **B and C** **C and D** **D and E**

answer [1]

(ii) Which letter represents the **output** from the **NOT** gate?

Choose from

- A** **B** **C** **D** **E** **F**

answer [1]

19

(iii) Here is part of the truth table for this combination of gates.

	A	B	C	D	E	F
row W	1	1	1	1	0	
row X	1	0	1	0	0	
row Y	0	1	0	0	1	
row Z	0	0	0	0	1	

Which row in the table will give an output of **0** at **F**?

Choose from

row W

row X

row Y

row Z

answer

[1]

[Total: 4]

Question 13 begins on page 20

13 George draws a current-voltage graph for five different ohmic conductors.

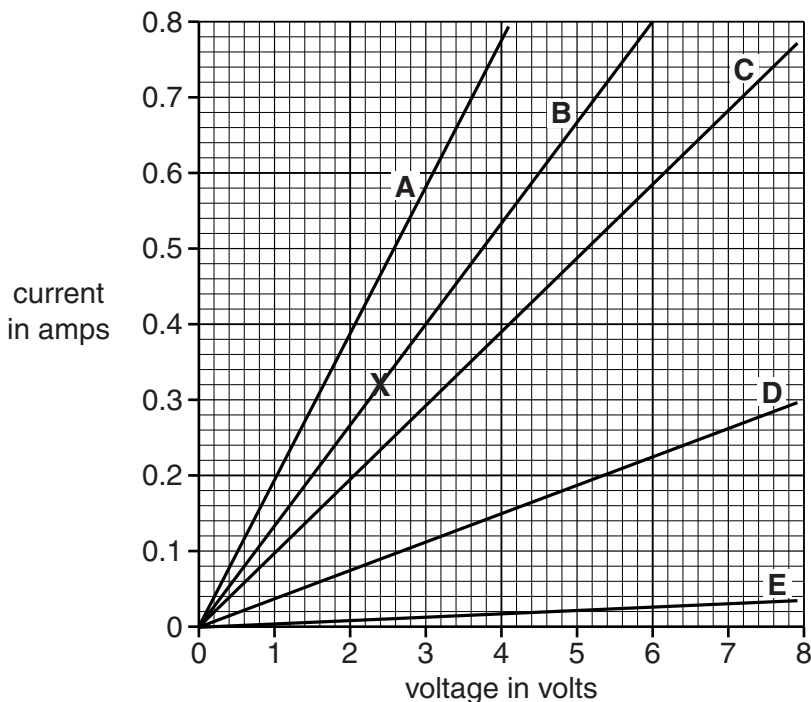

(a) Ohmic conductors obey Ohm's Law.

Complete the sentence.

All five conductors are ohmic because the lines pass through the origin and
 [1]

(b) Look at point X on the graph for conductor B.

(i) Complete the sentences.

The voltage at X is volts.

The current at X is amps.

[1]

(ii) Use your answers from (i) to calculate the resistance of conductor B.

Choose from

0.13 ohms

0.77 ohms

2.72 ohms

7.50 ohms

answer

[1]

21

(c) Which conductor has the greatest resistance?

Choose from

A B C D E

answer

[1]

(d) When the voltage is more than 6 volts conductor B gets hot.

George uses a model to explain resistance:

Current in a conductor is the flow of charge carriers called neutrons.
The charge carriers collide with the atoms (ions) in the conductor.
This explains electrical resistance.
As the conductor gets hotter the resistance stays the same.

George has made **two** mistakes.

Describe the two mistakes he has made and write down the corrections.

.....
.....
.....
.....

[2]

[Total: 6]

14 Electric motors are used in appliances in the home.

(a) A washing machine has an electric motor.

The motor moves the clothes and water.

Write down the name of **two** other appliances in the home that use electric motors and explain what the motor does.

.....

.....

.....

..... [2]

(b) Engineers try to make motors as efficient as possible by reducing waste energy through heating.

Look at the information about three new motors.

Name of motor	Efficiency of motor at different currents		
	2 amps	4 amps	6 amps
Duty	93%	92%	87%
Effortless	96%	93%	72%
Factor	95%	94%	87%

The engineer wants to use the motor with a 5 amp current.

Which motor should the engineer use?

.....

Explain your reasons for choosing this motor.

.....

.....

..... [2]

[Total: 4]

23

BLANK PAGE

Question 15 begins on page 24

PLEASE DO NOT WRITE ON THIS PAGE

SECTION D

15 Loud sounds can be dangerous and can damage human hearing.

(a) Look at the table about the loudness of different sounds.

Source	Sound	Loudness in dB
A	Busy road traffic	70
B	Front row at a music festival	110
C	Large orchestra	98
D	Aircraft at take off	145
E	Normal conversation	60
F	Rustling leaves	10
G	Vacuum cleaner	80
H	MP3 player at maximum volume	100

Sounds above 90 dB can damage hearing.

Which sources in the table are above 90 dB?

Choose from **A** **B** **C** **D** **E** **F** **G** **H**

answers [2]

(b) Lawnmowers make loud sounds above the safe loudness level of 90 dB.

The graph shows how the loudness changes as you move away from a lawnmower.

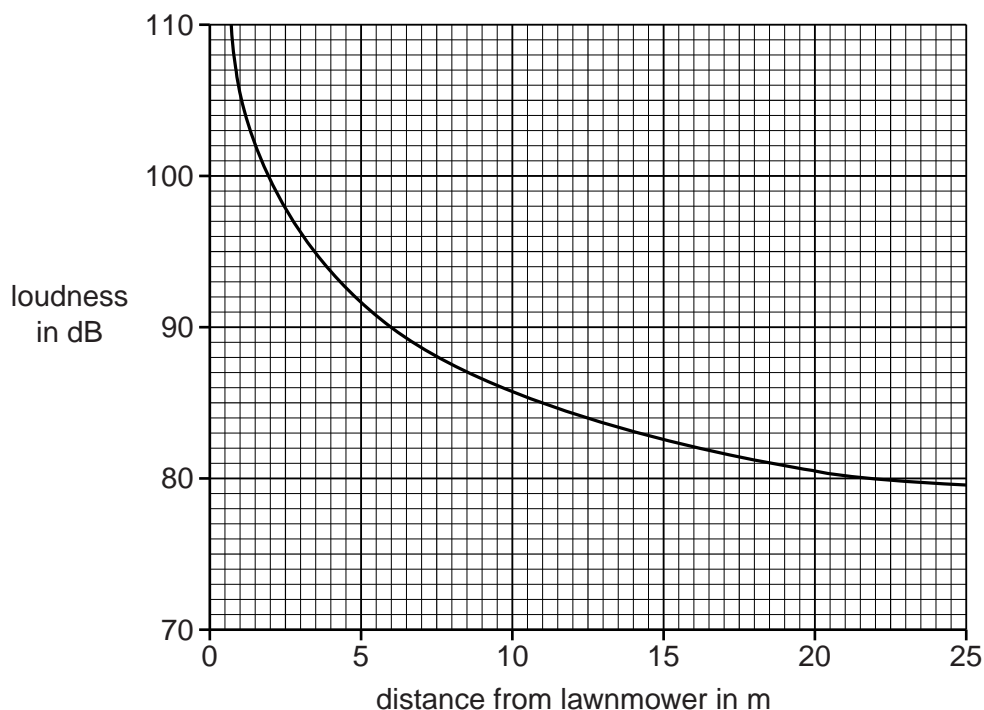

(i) Describe how loudness is affected by distance.

.....

.....

..... [2]

(ii) Use the graph to find the loudness when you are 15 m away from the lawnmower.

..... dB [1]

(iii) A gardener needs to wear ear protection when using the lawnmower.

People in a house nearby do **not** need ear protection when he is using the lawnmower.

Suggest reasons why the gardener needs to wear ear protection, but the people in the house do not.

.....

.....

.....

..... [2]

- (c) Sounds below 90 dB can also damage hearing if the sounds go on for a long time.

Look at the table on maximum safe exposure times.

Loudness in dB	Maximum safe exposure time
85	8 hours
88	
91	2 hours
94	1 hour
97	30 minutes
100	15 minutes
103	7.5 minutes
106	< 4 minutes

- (i) Estimate the maximum safe exposure time for a loudness of 88 dB.

..... [1]

- (ii) At 106 dB the maximum safe exposure time is < 4 minutes. What does this mean?

.....
 [1]

- (iii) Ravi lives near a noisy factory.

The maximum safe exposure time to the sound from the factory is 32 hours.

Calculate the loudness of the sound from the factory.

.....
 [1]

[Total: 10]

END OF QUESTION PAPER

27

BLANK PAGE

PLEASE DO NOT WRITE ON THIS PAGE

PLEASE DO NOT WRITE ON THIS PAGE



Copyright Information

OCR is committed to seeking permission to reproduce all third-party content that it uses in its assessment materials. OCR has attempted to identify and contact all copyright holders whose work is used in this paper. To avoid the issue of disclosure of answer-related information to candidates, all copyright acknowledgements are reproduced in the OCR Copyright Acknowledgements Booklet. This is produced for each series of examinations and is freely available to download from our public website (www.ocr.org.uk) after the live examination series.

If OCR has unwittingly failed to correctly acknowledge or clear any third-party content in this assessment material, OCR will be happy to correct its mistake at the earliest possible opportunity.

For queries or further information please contact the Copyright Team, First Floor, 9 Hills Road, Cambridge CB2 1GE.

OCR is part of the Cambridge Assessment Group; Cambridge Assessment is the brand name of University of Cambridge Local Examinations Syndicate (UCLES), which is itself a department of the University of Cambridge.