



Please write clearly in block capitals.

Centre number

--	--	--	--	--

Candidate number

--	--	--	--

Surname

\_\_\_\_\_

Forename(s)

\_\_\_\_\_

Candidate signature

\_\_\_\_\_

# GCSE SCIENCE A PHYSICS

# H

Higher Tier Unit Physics P1

Wednesday 25 May 2016

Afternoon

Time allowed: 1 hour

## Materials

For this paper you must have:

- a ruler
- a calculator
- the Physics Equations Sheet (enclosed).

## Instructions

- Use black ink or black ball-point pen.
- Fill in the boxes at the top of this page.
- Answer **all** questions.
- You must answer the questions in the spaces provided. Do not write outside the box around each page or on blank pages.
- Do all rough work in this book. Cross through any work you do not want to be marked.

## Information

- The marks for questions are shown in brackets.
- The maximum mark for this paper is 60.
- You are expected to use a calculator where appropriate.
- You are reminded of the need for good English and clear presentation in your answers.
- Question 2(b) should be answered in continuous prose.

In this question you will be marked on your ability to:

- use good English
- organise information clearly
- use specialist vocabulary where appropriate.

## Advice

- In all calculations, show clearly how you work out your answer.



J U N 1 6 P H 1 H P O 1

G/ED/Jun16/E5

**PH1HP**

Answer **all** questions in the spaces provided.

- 1** Bats use the reflection of high pitched sound waves to determine the position of objects. **Figure 1** shows a bat and an insect flying in front of the bat.

**Figure 1**

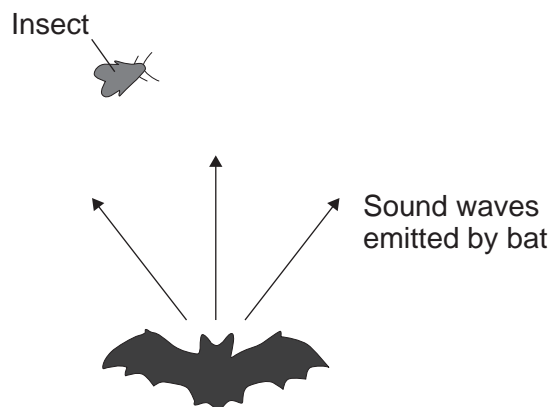

- 1 (a)** What determines the pitch of a sound wave?

[1 mark]

Tick (✓) **one** box.

	Tick (✓)
amplitude	
frequency	
speed	

- 1 (b)** State the name given to reflected sound waves.

[1 mark]

---



**1 (c)** The bat emits sound waves with a range of wavelengths.

Some of the sound waves will be diffracted by the insect.

Complete the following sentences to explain why.

**[2 marks]**

Diffraction is caused by the sound waves \_\_\_\_\_  
as they pass the insect.

The most diffraction happens when the wavelength of the sound wave is

\_\_\_\_\_ the size of the insect.

**1 (d)** The bat emits a sound wave with a frequency of 25.0 kHz and a wavelength of 0.0136 metres.

Calculate the speed of this sound wave.

Use the correct equation from the Physics Equations Sheet.

**[2 marks]**

\_\_\_\_\_  
\_\_\_\_\_  
\_\_\_\_\_

Speed = \_\_\_\_\_ m/s

**1 (e)** Sound waves are longitudinal. Describe a longitudinal sound wave.

**[2 marks]**

\_\_\_\_\_  
\_\_\_\_\_  
\_\_\_\_\_  
\_\_\_\_\_

8

Turn over ►



- 2 A small community of people live in an area in the mountains.  
The houses are not connected to the National Grid.

The people plan to buy an electricity generating system that uses either the wind or the flowing water in a nearby river.

**Figure 2** shows where these people live.

**Figure 2**



- 2 (a) It would not be economical to connect the houses to the National Grid.  
Give **one** reason why.

[1 mark]

---

---

---

---

- 2 (b) **In this question you will be assessed on using good English, organising information clearly and using specialist terms where appropriate.**

Information about the two electricity generation systems is given in **Figure 3**.

**Figure 3**

The wind turbine costs £50 000 to buy and install.  
The hydroelectric generator costs £20 000 to buy and install.  
The average power output from the wind turbine is 10 kW.  
The hydroelectric generator will produce a constant power output of 8 kW.



Compare the advantages and disadvantages of the two methods of generating electricity.

Use your knowledge of energy sources as well as information from **Figure 3**.

**[6 marks]**

---

---

---

---

---

---

---

---

---

---

---

---

---

---

---

---

---

---

---

---

---

---

---

Extra space

---

---

---

---

---

---

---

---

---

---

---

---

---

---

---

---

---

---

---

---

---

---

7
---

Turn over ►



3 (a) Heating food in a saucepan over a gas flame is inefficient. Suggest why.

[2 marks]

Four horizontal lines for writing the answer to question 3(a).

3 (b) A new saucepan has been designed that heats up food much faster than a traditional saucepan. Figure 4 shows the two saucepans.

Figure 4

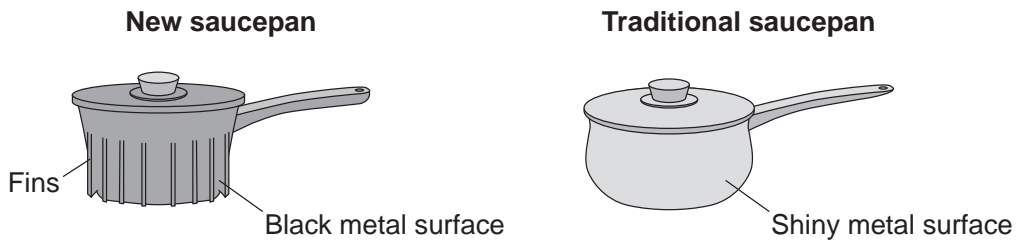

Describe how the features of the new saucepan cause the food to heat up faster than when the food is heated in the traditional saucepan.

[2 marks]

Fins \_\_\_\_\_  
\_\_\_\_\_

Black metal surface \_\_\_\_\_  
\_\_\_\_\_

3 (c) State the relationship between the temperature of the saucepan and the rate at which the saucepan emits infrared radiation.

[1 mark]

\_\_\_\_\_  
\_\_\_\_\_



4 Infrared and microwaves are two types of electromagnetic radiation.

4 (a) (i) State **one** example of the use of each type of radiation for communication.

[2 marks]

Infrared: \_\_\_\_\_

Microwaves: \_\_\_\_\_

4 (a) (ii) Some of the properties of infrared and microwaves are the same.

State **two** of these properties.

[2 marks]

1 \_\_\_\_\_

\_\_\_\_\_

2 \_\_\_\_\_

\_\_\_\_\_

4 (b) In 1964, physicists discovered microwave radiation that filled the universe.

4 (b) (i) Name this type of radiation.

[1 mark]

\_\_\_\_\_

4 (b) (ii) State the importance of this discovery made by the physicists.

[1 mark]

\_\_\_\_\_

\_\_\_\_\_

6

Turn over for the next question

Turn over ►



- 5 A new design for a kettle is made from two layers of plastic separated by a vacuum. After the water in the kettle has boiled, the water stays hot for at least 2 hours.

The new kettle is shown in **Figure 5**.

**Figure 5**

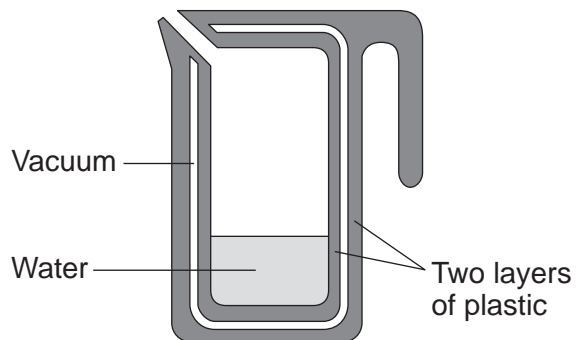

- 5 (a) Explain why the vacuum reduces energy transfer to the surroundings.

[2 marks]

---

---

---

---





**5 (b)** The energy transferred from the water in the kettle to the surroundings in 2 hours is 46 200 J.

The mass of water in the kettle is 0.50 kg.

The specific heat capacity of water is 4200 J/kg °C.

The initial temperature of the water is 100 °C.

**5 (b) (i)** Calculate the temperature of the water in the kettle after 2 hours.

Use the correct equation from the Physics Equations Sheet.

**[3 marks]**

---

---

---

---

Temperature after 2 hours = \_\_\_\_\_ °C

**5 (b) (ii)** Calculate the average power output from the water in the kettle to the surroundings in 2 hours.

Use the correct equation from the Physics Equations Sheet.

**[2 marks]**

---

---

---

---

Average power output = \_\_\_\_\_ W

7

**Turn over for the next question**

**Turn over ►**



- 6 All European Union countries are expected to generate 20% of their electricity using renewable energy sources by 2020.

The estimated cost of generating electricity in the year 2020 using different energy sources is shown in **Table 1**.

**Table 1**

Energy source	Estimated cost (in the year 2020) in pence per kWh
Nuclear	7.8
Solar	25.3
Tidal	18.8
Wind	10.0

France generated 542 billion kWh of electricity using nuclear power stations in 2011. France used 478 billion kWh of electricity and sold the rest of the electricity to other countries in 2011.

- 6 (a) France may continue generating large amounts of electricity using nuclear power stations instead of using renewable energy resources.

Suggest **two** reasons why.

**[2 marks]**

1 \_\_\_\_\_

\_\_\_\_\_

2 \_\_\_\_\_

\_\_\_\_\_



**6 (b)** Give **two** disadvantages of generating electricity using nuclear power stations.

**[2 marks]**

1 \_\_\_\_\_

\_\_\_\_\_

2 \_\_\_\_\_

\_\_\_\_\_

**6 (c)** A panel of solar cells has an efficiency of 0.15.

The total power input to the panel of solar cells is 3.2 kW.

Calculate the useful power output of this panel of solar cells in kW.

Use the correct equation from the Physics Equations Sheet.

**[2 marks]**

\_\_\_\_\_

\_\_\_\_\_

\_\_\_\_\_

\_\_\_\_\_

Useful power output = \_\_\_\_\_ kW

**Question 6 continues on the next page**

**Turn over ►**



- 6 (d)** **Table 2** shows the manufacturing cost and efficiency of different types of panels of solar cells.

**Table 2**

Type of Solar Panel	Cost to manufacture a 1 m <sup>2</sup> solar panel in £	Efficiency in %
A	40.00	20
B	22.50	15
C	5.00	10

Some scientists think that having a low manufacturing cost is more important than improving the efficiency of solar cells.

Use information from **Table 2** to suggest why.

**[2 marks]**

---

---

---

---

---

---

---

8



**Turn over for the next question**

**DO NOT WRITE ON THIS PAGE  
ANSWER IN THE SPACES PROVIDED**

**Turn over ►**



- 7 A student investigated the cooling effect of evaporation. She used the equipment in **Figure 6** to measure how the temperature of three different liquids changed as the liquids evaporated.

**Figure 6**

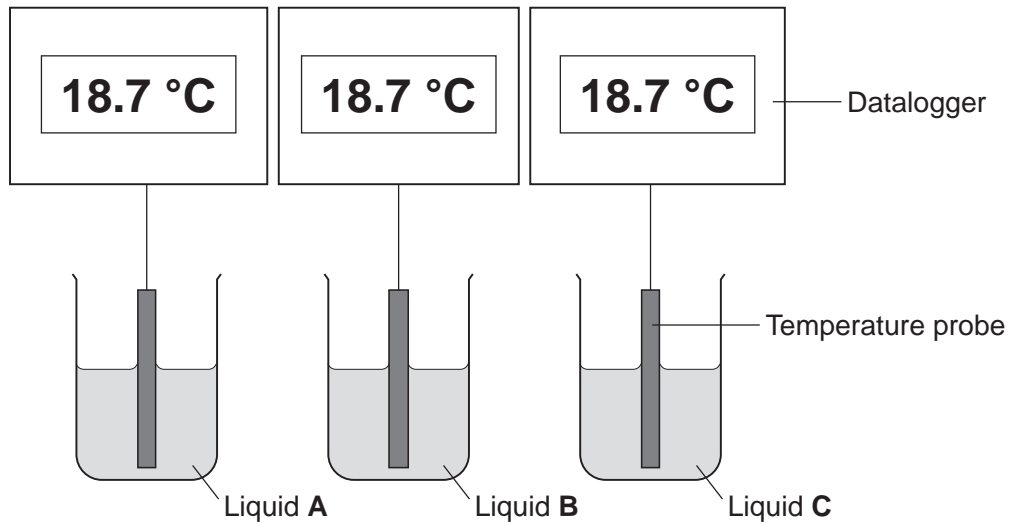

- 7 (a) The temperature and volume of each liquid was the same at the start of the investigation.

State **one** further control variable in this investigation.

[1 mark]

---

---



7 (b) Give **two** advantages of using dataloggers and temperature probes compared to using the thermometer shown in **Figure 7**.

Figure 7

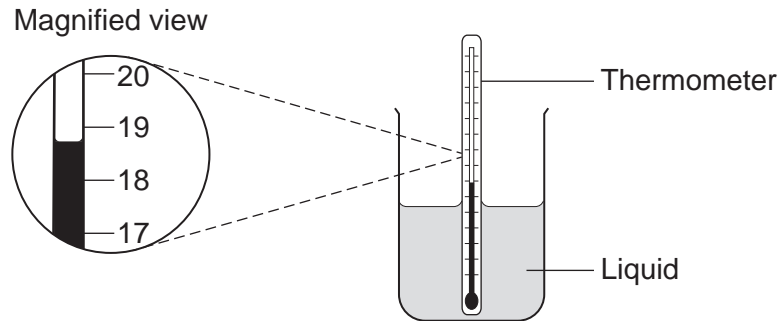

[2 marks]

1 \_\_\_\_\_

\_\_\_\_\_

2 \_\_\_\_\_

\_\_\_\_\_

Question 7 continues on the next page

Turn over ►



7 (c) The student's results are shown in **Figure 8**.

**Figure 8**

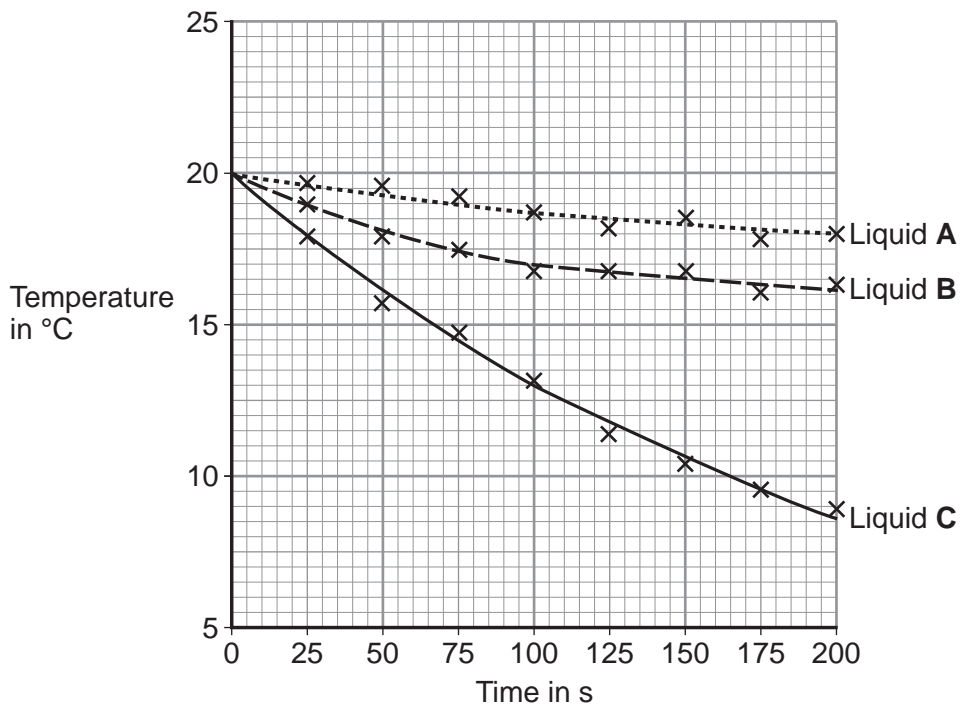

7 (c) (i) Calculate the average rate of temperature decrease of liquid **C** between 0 and 100 seconds.

[2 marks]

---



---

Average rate of temperature decrease = \_\_\_\_\_ °C / s

7 (c) (ii) Give **one** conclusion that can be made about the rate of temperature decrease of **all three** liquids from the results in **Figure 8**.

[1 mark]

---



---





7 (c) (iii) Which liquid had the lowest rate of evaporation? Give a reason for your answer.

[1 mark]

Liquid \_\_\_\_\_

Reason \_\_\_\_\_

\_\_\_\_\_

7 (c) (iv) A second student did the same investigation but using a smaller volume of liquid than the first student.

All other variables were kept the same.

What effect would this have on the results of the second student's investigation?

[1 mark]

\_\_\_\_\_

\_\_\_\_\_

7 (d) Explain how the evaporation of a liquid causes the temperature of the remaining liquid to decrease.

[3 marks]

\_\_\_\_\_

\_\_\_\_\_

\_\_\_\_\_

\_\_\_\_\_

\_\_\_\_\_

\_\_\_\_\_

\_\_\_\_\_

\_\_\_\_\_

11

Turn over for the next question

Turn over ►



**8** A heater uses energy from a laptop computer to keep a mug of coffee hot.

**Figure 9** shows the heater connected to a laptop computer.

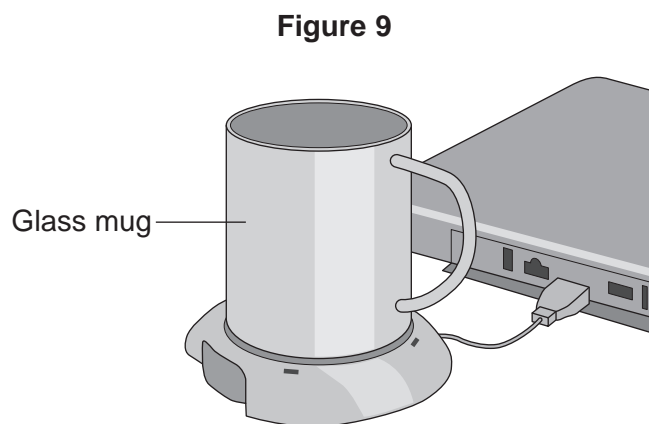

**8 (a)** Give **two** factors, other than the material of the mug, that would affect the rate of energy transfer to the coffee.

[2 marks]

1 \_\_\_\_\_

2 \_\_\_\_\_

**8 (b)** Energy is conducted slowly through the base of the glass mug.

Explain how energy is conducted through the base of the glass mug.

[2 marks]

\_\_\_\_\_

\_\_\_\_\_

\_\_\_\_\_

\_\_\_\_\_



**8 (c)** Energy is transferred to the coffee at the bottom of the mug.

Explain how a convection current is set up in the coffee.

**[4 marks]**

---

---

---

---

---

---

---

---

---

---

<b>8</b>

**END OF QUESTIONS**



**There are no questions printed on this page**

**DO NOT WRITE ON THIS PAGE  
ANSWER IN THE SPACES PROVIDED**

**Copyright information**

For confidentiality purposes, from the November 2015 examination series, acknowledgements of third party copyright material will be published in a separate booklet rather than including them on the examination paper or support materials. This booklet is published after each examination series and is available for free download from [www.aqa.org.uk](http://www.aqa.org.uk) after the live examination series.

Permission to reproduce all copyright material has been applied for. In some cases, efforts to contact copyright-holders may have been unsuccessful and AQA will be happy to rectify any omissions of acknowledgements. If you have any queries please contact the Copyright Team, AQA, Stag Hill House, Guildford, GU2 7XJ.

Copyright © 2016 AQA and its licensors. All rights reserved.

