

- 1 Fig. 3.1 shows an arrangement used to accelerate electrons.

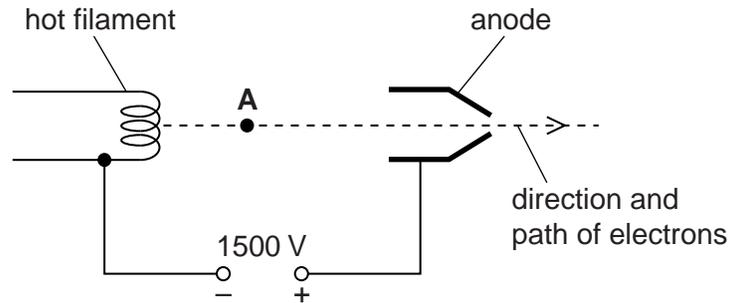

Fig. 3.1

- (a) Draw an arrow on Fig. 3.1 to show the direction of the electric field at point **A**. **[1]**
- (b) The potential difference between the filament and the anode is 1500V. The speed of an electron at the filament is negligible.
- (i) Determine the kinetic energy in electronvolts (eV) of an electron at the anode.

kinetic energy =eV **[1]**

- (ii) Calculate the speed v of an electron at the anode.

$v = \dots\dots\dots \text{ms}^{-1}$ **[3]**

- (c) The electrons from the arrangement shown in Fig. 3.1 enter a region of space occupied by both uniform electric and magnetic fields, as shown in Fig. 3.2.

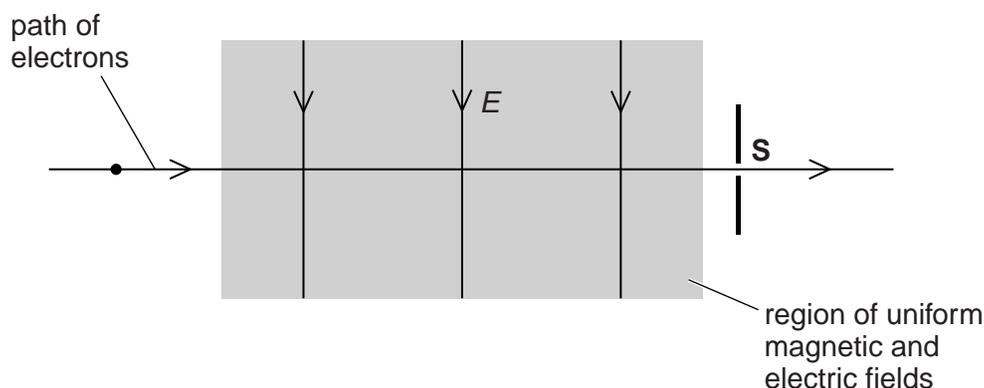

Fig. 3.2

The electric field strength of the electric field is E and its direction is shown in Fig. 3.2. The magnetic flux density of the magnetic field is B . The direction of the magnetic field is perpendicular to E and directed into the plane of the paper. B is increased until all the electrons pass through the slit **S** at a particular speed v . The path of the electrons is now horizontal as shown.

- (i) Derive an expression for v in terms of E and B .

[2]

- (ii) The magnetic flux density is increased further. The electric field strength is unchanged. Describe and explain what happens to the path of the electrons.

.....

.....

.....

[2]

[Total: 9]

2 (a) Fig. 3.1 shows two charged horizontal plates.



Fig. 3.1

The potential difference across the plates is 60V. The separation of the plates is 5.0mm.

- (i) On Fig. 3.1 draw the electric field pattern between the plates. [2]
- (ii) Calculate the electric field strength between the plates.

electric field strength =V m⁻¹ [1]

- (b) Positive ions are accelerated from rest in the horizontal direction through a potential difference of 400V. The charged plates in (a) are then used to deflect the ions in the vertical direction. Fig. 3.2 shows the path of these ions.

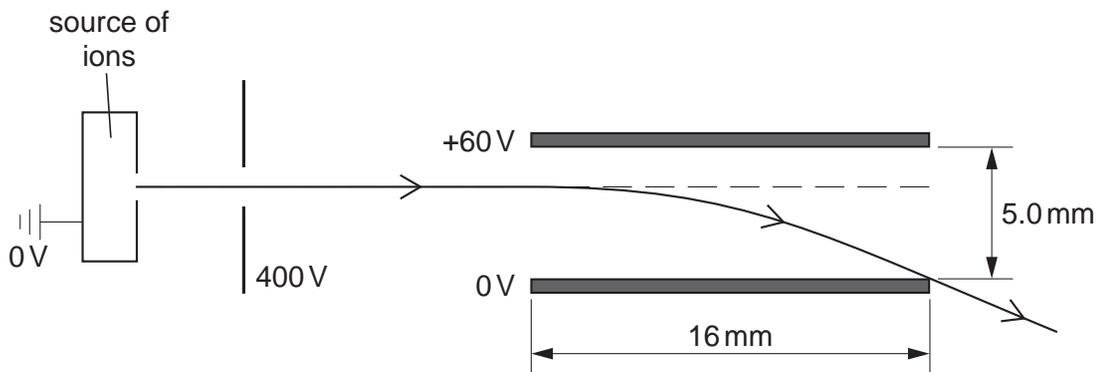

Fig. 3.2

Each ion has a mass of 6.6×10^{-27} kg and a charge of 3.2×10^{-19} C.

- (i) Show that the horizontal velocity of an ion after the acceleration by the 400V potential difference is 2.0×10^5 ms⁻¹.

[2]

- (ii) The ions enter at right angles to the uniform electric field between the plates. Calculate the vertical acceleration of an ion due to this electric field.

acceleration = ms⁻² [2]

- (iii) The length of each of the charged plates is 16 mm.

- 1 Show that an ion takes about 8.0×10^{-8} s to travel through the plates.

[1]

- 2 Calculate the vertical deflection of an ion as it travels through the plates.

deflection = m [2]

- (c) A uniform magnetic field is applied in the region between the plates in Fig. 3.2. The magnetic field is perpendicular to both the path of the ions and the electric field between the plates.

Calculate the magnitude of the magnetic flux density of field needed to make the ions travel horizontally through the plates.

magnetic flux density = T [3]

- (d) Ions of the same charge but greater mass are accelerated by the potential difference of 400V described in (b). Describe and explain the effect on the deflection of the ions after they have travelled between the plates using the same electric and magnetic fields of (c).

.....
.....
.....
..... [2]

[Total: 15]

3 A proton travelling at a high velocity is fired at a stationary proton. It stops momentarily at a distance of 2.0×10^{-15} m from the stationary proton.

(a) Calculate the electrostatic force acting on each proton when separated by 2.0×10^{-15} m.

force = N **[2]**

(b) The two protons fuse together. Explain how the protons are able to remain together.

.....
..... **[1]**

(c) Explain why the proton must have a very large velocity for the fusion to occur and the protons to remain together.

.....
.....
.....
..... **[2]**

[Total: 5]