

## Nuclear Structure and Particle Accelerators

Q1.

The diagram shows a model used to demonstrate alpha particle scattering. A ball bearing is set rolling on a wooden track. The track is positioned so that the ball bearing rolls onto a metal sheet with a curved surface known as a 'hill'.

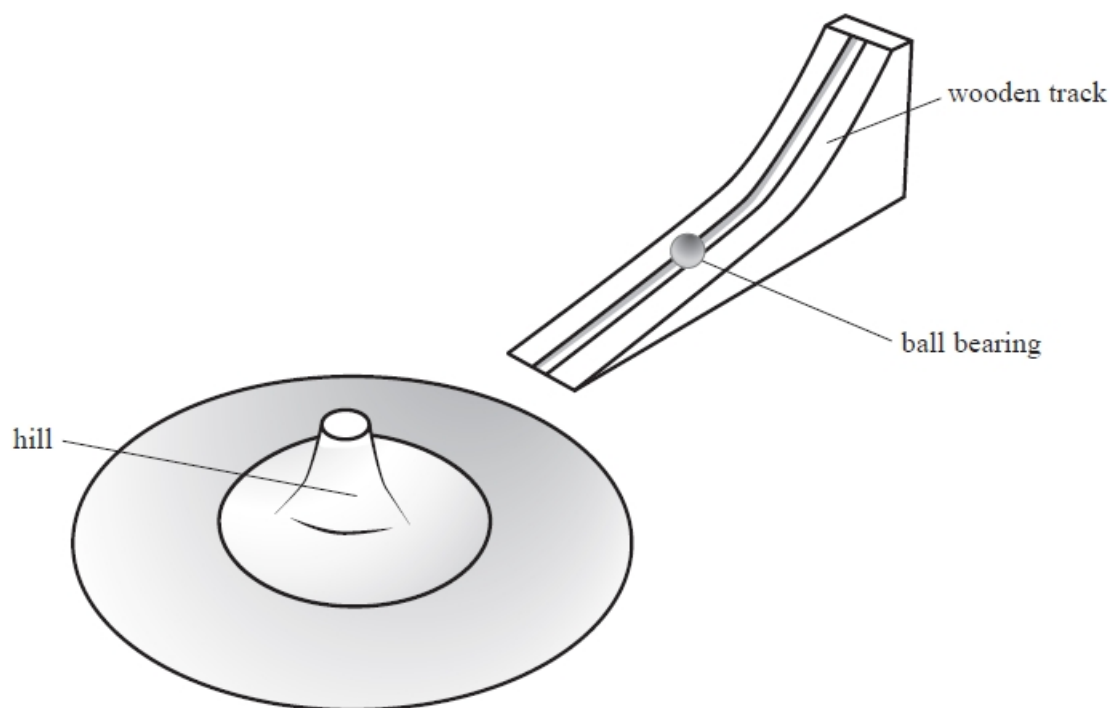

The diagram shows a vertical cross-section through the hill. The surface is curved so that the height of a point  $h$  on the curved surface is inversely proportional to the distance  $r$  from the centre of the hill.

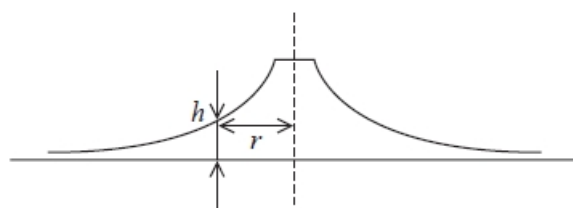

A plan view of the arrangement is shown.

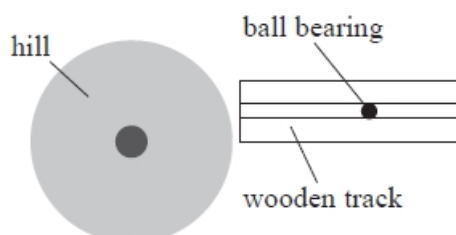

The wooden track is moved to different positions and the ball bearing is released.

Describe the results of the alpha particle scattering experiment and how these can be demonstrated by moving the wooden track to different positions.

(4)

.....

.....

.....

.....

.....

.....

.....

(Total for question = 4 marks)

**Q2.**

Alpha particle scattering investigations were first carried out in the early part of the 20th century.

An alpha particle with initial kinetic energy  $8.8 \times 10^{-13} \text{ J}$  approaches a nucleus of a gold  ${}_{79}^{197}\text{Au}$  atom.

Which of the following is an equation for the closest distance  $r$ , in metres, between the alpha particle and the nucleus?

A  $r = 8.99 \times 10^9 \left( \frac{2 \times 1.6 \times 10^{-19} \times 79 \times 1.6 \times 10^{-19}}{8.8 \times 10^{-13}} \right)$

B  $r = \frac{2 \times 1.6 \times 10^{-19} \times 197 \times 1.6 \times 10^{-19}}{8.99 \times 10^9 \times 8.8 \times 10^{-13}}$

C  $r = 8.99 \times 10^9 \left( \frac{8.8 \times 10^{-13}}{4 \times 1.6 \times 10^{-19} \times 79 \times 1.6 \times 10^{-19}} \right)$

D  $r = 8.99 \times 10^9 \left( \frac{2 \times 79}{8.8 \times 10^{-13}} \right)$

(Total for question = 1 mark)

**Q3.**

Alpha particle scattering investigations were first carried out in the early part of the 20th century.

Which of the following conclusions could **not** be made as a result of these investigations?

- A** The atom is mostly empty space.
- B** The atom is neutral.
- C** The nucleus is charged.
- D** The nucleus is very small compared to the atom.

**(Total for question = 1 mark)**

**Q4.**

The solid line shows the path of an alpha particle as it passes close to a nucleus.

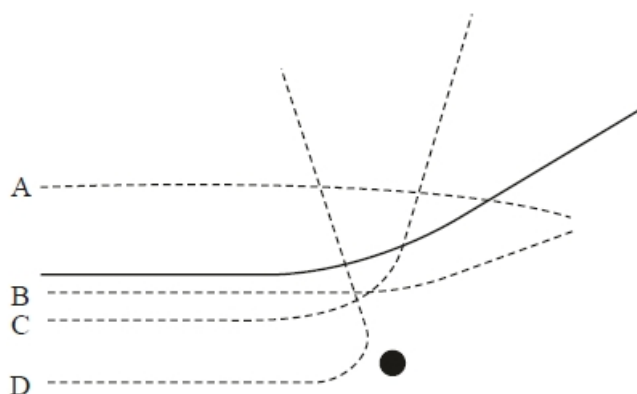

Another alpha particle approaches the nucleus with the same initial kinetic energy.

Which dashed path is possible for this alpha particle?

- A**
- B**
- C**
- D**

**(Total for question = 1 mark)**

**Q5.**

At the beginning of the 20th century, Rutherford carried out large-angle alpha particle scattering experiments using gold ( $^{197}_{79}\text{Au}$ ) foil.

The vast majority of the alpha particles went straight through the foil whilst a few were deflected straight back.

Describe how the model of the atom changed, as a consequence of these experiments.

(4)

.....

.....

.....

.....

.....

.....

.....

.....

**(Total for question = 4 marks)**

**Q6.**

At the beginning of the 20th century, Rutherford carried out large-angle alpha particle scattering experiments using gold ( $^{197}_{79}\text{Au}$ ) foil.

The vast majority of the alpha particles went straight through the foil whilst a few were deflected straight back.

In one experiment the alpha particles had an initial energy of 7.7 MeV.

Calculate the distance of closest approach of the alpha particles to the nucleus of a gold atom. Assume that the gold nucleus remains at rest.

(4)

.....

.....

.....

.....

.....

.....

.....

.....

Distance of closest approach = .....

**(Total for question = 4 marks)**

**Q7.**

At the end of the 19<sup>th</sup> century, J.J. Thompson used electric and magnetic fields to deflect beams of charged particles. A photograph of his apparatus is shown.



© Science Museum London

Electrons were accelerated through a potential difference to produce a beam of high-energy electrons. The beam was then deflected in perpendicular directions by the magnetic and electric fields. The final position of the beam on the screen was determined by the charge and mass of the electrons.

In his original experiments, Thompson determined the specific charge of a range of particles. His results indicated that the specific charge of an electron is about 2000 times bigger than that for a hydrogen ion.

Deduce what conclusion can be made from this information.

**(1)**

.....

.....

**(Total for question = 1 mark)**

**Q8.**

Cathode ray tubes are used in oscilloscopes.



The diagram shows a simplified cathode ray tube that can be used to determine the magnitude and polarity of a potential difference (p.d.).

The cathode ray tube consists of an electron gun, a pair of deflecting plates and a fluorescent screen.

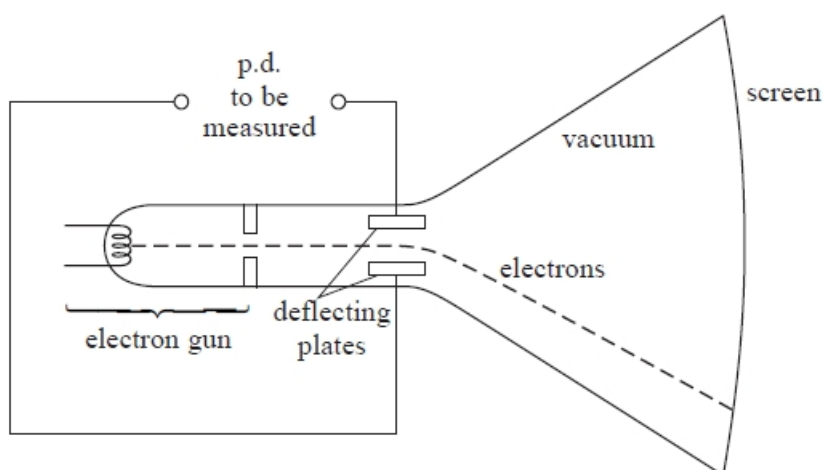

(a) The electron gun includes a filament. When this filament is heated, electrons are released and are accelerated by a p.d. of 1.5 kV to form an electron beam.

(i) Name the process by which electrons are released from the heated filament.

(1)

.....

(ii) Show that the maximum velocity of the electrons is about  $2 \times 10^7 \text{ m s}^{-1}$ .

(2)

.....

.....

.....

.....

(b) The electron beam then enters a uniform electric field between the two parallel horizontal deflecting plates. The magnitude and direction of the deflection is determined by the p.d.  $V$  that is applied across the plates.

The diagram shows one possible path of the electron beam as it passes between the plates.

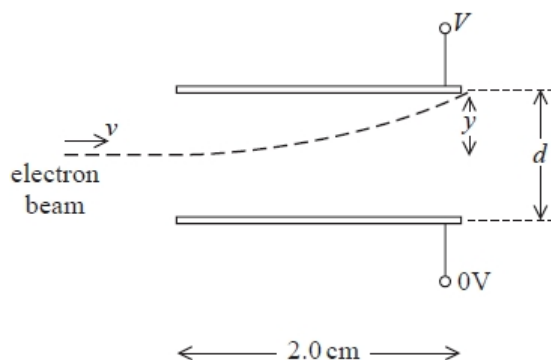

(i) Show that the acceleration of an electron, of mass  $m$  and charge  $Q$ , is given by

$$\frac{VQ}{dm}$$

(2)

.....

.....

.....

.....

(ii) Calculate the magnitude of the vertical deflection  $y$  of the beam as it leaves the plates.

$V = 50 \text{ V}$   
 $d = 0.01 \text{ m}$

(5)

.....

.....

.....

.....

.....

.....

.....

.....

.....

.....

$y = \text{.....}$

(c) A laboratory oscilloscope with the time base turned off operates in the same way as this simplified cathode ray tube. A student uses an oscilloscope in this way to monitor an alternating p.d. of  $53 \text{ V}_{\text{rms}}$

On the grid, draw the trace that would be seen on the screen.

(4)

.....  
 .....

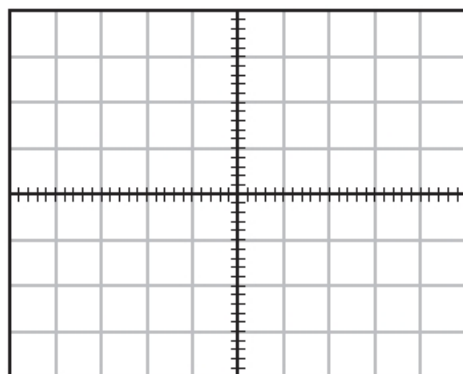

1 square = 25 V

(Total for question = 14 marks)

**Q9.**

A series of experiments was carried out in the 1970s to investigate the structure of protons using the linac at Stanford, USA.

\* Explain how an electron is accelerated in a linac.

(6)

.....  
 .....



.....

.....

.....

.....

.....

.....

.....

**(Total for question = 6 marks)**

**Q10.**

A series of experiments was carried out in the 1970s to investigate the structure of protons using the linac at Stanford, USA.

The electron leaves the accelerator with a high energy.

Explain why electrons need high energies to investigate the structure of a proton.

**(2)**

.....

.....

.....

.....

**(Total for question = 2 marks)**

**Q11.**

Proton beam therapy is being introduced in the UK as a new cancer treatment.

A beam of protons is accelerated by a cyclotron to an energy of 23 MeV and is then focused onto a tumour.

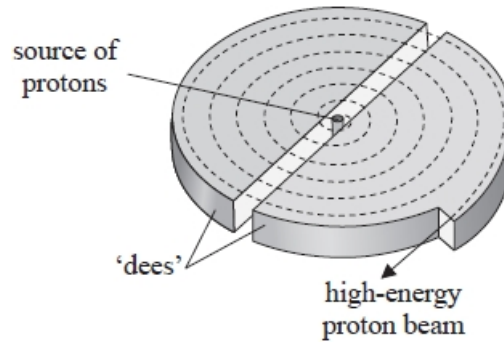

\* Explain how the cyclotron produces the high-energy proton beam.

(6)

.....

.....

.....

.....

.....

.....

.....

.....

.....

.....

.....

.....

.....

.....

.....

.....

.....

.....

.....

.....

**(Total for question = 6 marks)**

**Q12.**

The following extract is taken from a quote by Rutherford, speaking about the scattering of alpha particles by a thin gold foil.

We knew the alpha particle was a very fast, massive particle with a great deal of energy, and the chance of an alpha particle being scattered backward was very small. Then I remember two or three days later Geiger coming to me in great excitement and saying "We have been able to get some of the alpha particles coming backward ..." It was almost as incredible as if you fired a 15-inch shell at a piece of tissue paper and it came back and hit you.

(a) Rutherford compared the scattering of alpha particle through large angles to firing "a 15-inch shell at a piece of tissue paper and it came back and hit you."

Explain, with reference to the properties of the alpha particle, why a relatively large force is needed to deflect alpha particles through a large angle.

(2)

.....

.....

.....

.....

(b) Before the alpha particle scattering experiment, scientists believed that the mass and charge of an atom were uniformly distributed throughout the atom in a radius of about  $1.4 \times 10^{-10}$  m. Following the scattering experiments, a model of the atom was developed in which there was a concentrated centre of charge called the nucleus.

Assess the validity of this model of the atom given that the magnitude of the force required to scatter these alpha particles by a large angle is about 2.0 N. You should include a calculation in your answer.

proton number of gold = 79

(5)

.....

.....

.....

.....

.....

.....

.....

.....



**Q14.**

A negatively charged pion decays into a muon and an antineutrino. The diagram shows tracks in a particle detector formed in such an event.

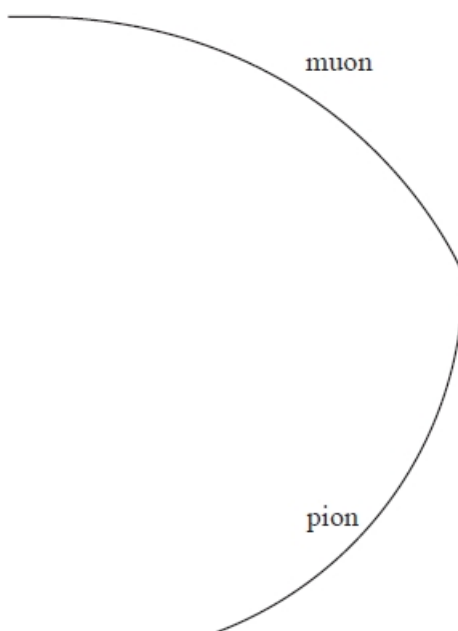

The momentum of the pion just before it decays is  $9.1 \times 10^{-20} \text{ N s}$ .

Determine the magnetic flux density of the magnetic field which acts in the detector and state its direction.

Scale of diagram 1 cm represents 10 cm

pion charge =  $-1.6 \times 10^{-19} \text{ C}$

(4)

.....

.....

.....

.....

.....

.....

.....

.....

Magnetic flux density = .....

Direction of magnetic field = .....

**(Total for question = 4 marks)**

**Q15.**

The diagram shows a model used to demonstrate alpha particle scattering. A ball bearing is set rolling on a wooden track. The track is positioned so that the ball bearing rolls onto a metal sheet with a curved surface known as a 'hill'.

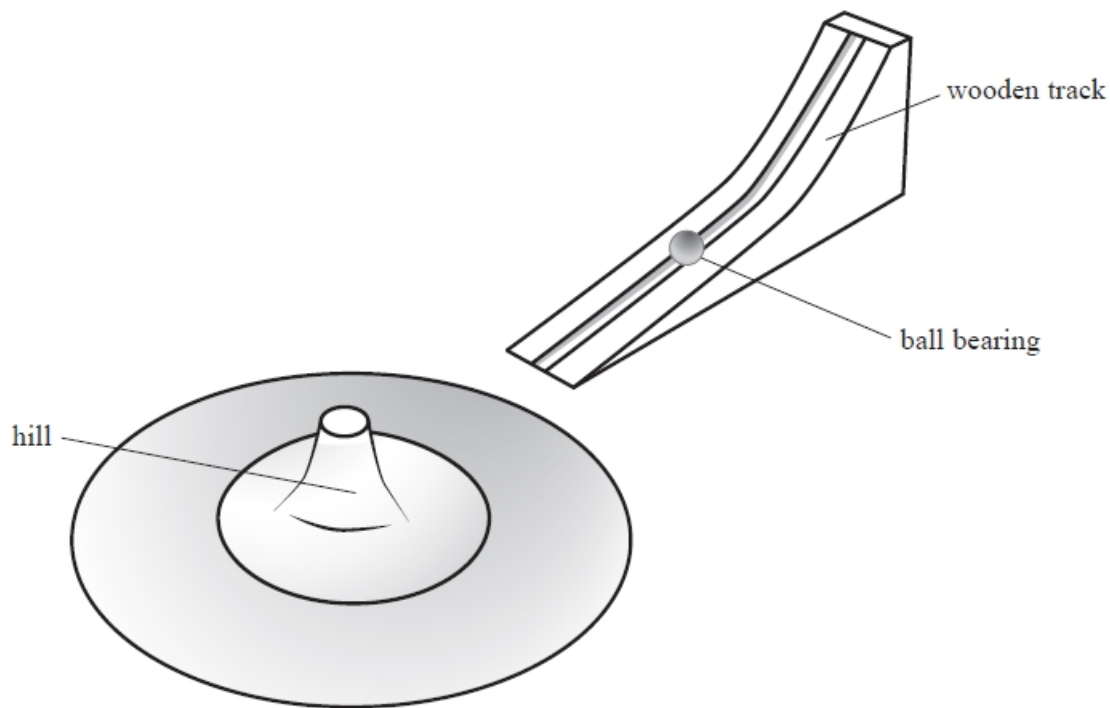

The diagram shows a vertical cross-section through the hill. The surface is curved so that the height of a point  $h$  on the curved surface is inversely proportional to the distance  $r$  from the centre of the hill.

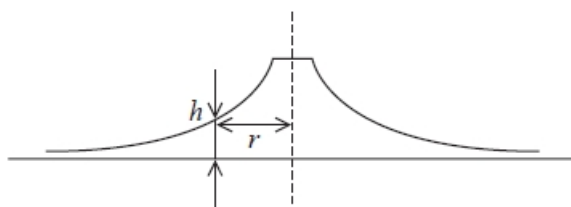

Explain why the hill is suitable as a model for the electric field surrounding the nucleus of an atom.

(3)

.....

.....

.....

.....

.....

**(Total for question = 3 marks)**

**Q16.**

The alpha particle scattering experiment led to a number of observations and conclusions.

Which row in the table gives a correct observation and corresponding conclusion from the alpha particle scattering experiment?

(1)

	Observation	Conclusion
<input type="checkbox"/> A	Most alpha particles come straight back.	The nucleus is charged.
<input type="checkbox"/> B	Most alpha particles come straight back.	The atom is mainly empty space.
<input type="checkbox"/> C	Most alpha particles go straight through.	The atom is mainly empty space.
<input type="checkbox"/> D	Most alpha particles go straight through.	The nucleus is charged.

**(Total for question = 1 mark)****Q17.**

Electric and magnetic fields can be used in particle accelerators.

Which row in the table correctly describes the use of electric and magnetic fields in the particle accelerator indicated?

	Particle accelerator	Magnetic field	Electric field
<input type="checkbox"/> A	cyclotron	not used	used to accelerate particles
<input type="checkbox"/> B	cyclotron	used to accelerate particles	used to accelerate particles
<input type="checkbox"/> C	linac	used to accelerate particles	not used
<input type="checkbox"/> D	linac	used to accelerate particles	used to accelerate particles

**(Total for question = 1 mark)**

**Q18.**

Rutherford's alpha-scattering experiment gave evidence that changed our understanding of the structure of the atom. Alpha particles were fired at a thin sheet of gold foil and their paths observed.

Explain how the observations of the different paths taken by the alpha particles as they passed through the gold foil led to a new model of the atom.

.....

.....

.....

.....

.....

.....

.....

.....

.....

.....

**(Total for question = 4 marks)**

**Q19.**

The number of neutrons in a nucleus of  ${}_{92}^{238}\text{U}$  is

- A** 92
- B** 146
- C** 238
- D** 330

**(Total for question = 1 mark)**



**Q20.**

At the end of the 19<sup>th</sup> century, J.J. Thompson used electric and magnetic fields to deflect beams of charged particles. A photograph of his apparatus is shown.



© Science Museum London

Electrons were accelerated through a potential difference to produce a beam of high-energy electrons. The beam was then deflected in perpendicular directions by the magnetic and electric fields. The final position of the beam on the screen was determined by the charge and mass of the electrons.

Explain how electrons from the source become a beam of high-energy electrons.

(2)

.....

.....

.....

.....

**(Total for question = 2 marks)**

## Mark Scheme – Nuclear Structure and Particle Acceleration

Q1.

Question Number	Acceptable answers	Additional guidance	Mark
	<p>Maximum of 4 marks for MP1,3,5 and any one of MP2,4 or 6</p> <ul style="list-style-type: none"> <li>• a few alpha's reflect straight back (1)</li> <li>• can be represented by the ball bearing being directly aimed at the centre of the "hill" (1)</li> <li>• some alpha's slightly deflected/through small angles (1)</li> <li>• can be represented by the ball bearing being aimed close to the centre line of the hill (1)</li> <li>• Many/most alpha's undeflected (1)</li> <li>• can be shown by aiming the ball bearing so that it touches/misses the edge of the hill (1)</li> </ul>	<p>accept deflect through large angles/more than <math>90^\circ</math></p> <p>MP2 dependent on being linked to MP1</p> <p>MP4 dependent on being linked to MP3</p> <p>MP6 dependent on being linked to MP5</p>	<b>4 Max</b>

Q2.

Question Number	Acceptable answers	Additional guidance	Mark
	<p><b>The only correct answer is A</b>  <i>B is not correct because the charge on an Au nucleus is <math>79 \times 1.6 \times 10^{-19}C</math></i>  <i>C is not correct because the charge on an alpha particle is <math>2 \times 1.6 \times 10^{-19}C</math></i>  <i>D is not correct because the charges have not been converted to C</i></p>		<b>1</b>

Q3.

Question Number	Acceptable answers	Additional guidance	Mark
	<p><b>The only correct answer is B</b>  <i>A is not correct because it is a correct conclusion</i>  <i>C is not correct because it is a correct conclusion</i>  <i>D is not correct because it is a correct conclusion</i></p>		<b>1</b>

Q4.

Question Number	Acceptable answers	Additional guidance	Mark
	C		1

Q5.

Question Number	Acceptable answers	Additional guidance	Mark
	<p>Before scattering experiment:</p> <ul style="list-style-type: none"> <li>atom containing equally distributed mass/charge (1)</li> </ul> <p>After experiment:</p> <ul style="list-style-type: none"> <li>very small nucleus containing (almost all) the mass of the atom (1)</li> <li>atom mainly empty space (1)</li> <li>nucleus is charged (1)</li> </ul>	alt: reference to 'plum pudding model'	4

Q6.

Question Number	Acceptable answers	Additional guidance	Mark
	<ul style="list-style-type: none"> <li>Use of <math>V = Q/4\pi\epsilon_0 r</math> (1)</li> <li>Conversion MeV to J (1)</li> <li>Use of <math>V = W/Q</math> (1)</li> <li><math>r = 3.0 \times 10^{-14} \text{m}</math> (1)</li> </ul>	<p>allow for <math>Q = 2</math> or <math>79</math>, accept <math>V = kQ/r</math></p> <p>Must use <math>e = 1.6 \times 10^{-19} \text{C}</math> to convert atomic number to C</p> <p><u>Example of calculation:</u></p> $7.7 \times 10^6 \text{eV} \times 1.6 \times 10^{-19} \text{J eV}^{-1}$ $= 8.99 \times 10^9 \text{N m}^2 \text{C}^{-2} \times 2 \times 79 \times$ $(1.6 \times 10^{-19} \text{C})^2 \div r$ $r = 2.27 \times 10^{-7} \div 7.7 \times 10^6$ $r = 2.95 \times 10^{-14} \text{m}$	4

Q7.

Question Number	Acceptable Answer	Additional Guidance	Mark
	<ul style="list-style-type: none"> <li>The hydrogen ion must be (about 2000 times) more massive than the electron</li> <li>Or the electron must be (about 2000 times) less massive than the hydrogen ion</li> </ul> <p style="text-align: right;">(1)</p>	Accept "proton" for "hydrogen ion"	1

Q8.

Question Number	Answer	Additional guidance	Mark
(a)(i)	thermionic emission		(1)

Question Number	Acceptable Answer	Additional guidance	Mark
(a)(ii)	<ul style="list-style-type: none"> <li>equate <math>\frac{1}{2}mv^2</math> and <math>VQ</math> (1)</li> <li><math>v = 2.3 \times 10^7 \text{ m s}^{-1}</math> (1)</li> </ul>	<p><u>Example of calculation:</u>  <math>E = 1500 \text{ V} \times 1.6 \times 10^{-19} \text{ C} = 2.4 \times 10^{-16} \text{ J}</math></p> $v = \sqrt{\frac{2 \times 2.4 \times 10^{-16} \text{ J}}{9.11 \times 10^{-31} \text{ kg}}} = 2.3 \times 10^7 \text{ m s}^{-1}$	(2)

Question Number	Acceptable Answer	Additional guidance	Mark
(b)(i)	<ul style="list-style-type: none"> <li>use of <math>F = EQ</math> and <math>E = \frac{v}{d}</math> (1)  OR see <math>F = \frac{vQ}{d}</math></li> <li>equate <math>F = ma</math> and <math>F = EQ</math> (1)</li> </ul>		(2)

Question Number	Acceptable Answer	Additional guidance	Mark
(b)(ii)	<ul style="list-style-type: none"> <li>• use of speed = distance/time (1)</li> <li>• <math>t = 8.7 \times 10^{-10}</math> (s) (1)</li> <li>• use of <math>a = \frac{vQ}{dm}</math> (1)</li> <li>• use of <math>s = ut + \frac{1}{2}at^2</math> (1) with <math>u = 0</math> and vertical acceleration to find <math>s</math></li> <li>• <math>s = 3.3 \times 10^{-4}</math> m (1)</li> </ul>	<p><u>Example of calculation:</u></p> $t = \frac{0.02 \text{ m}}{2.3 \times 10^7 \text{ m s}^{-1}} = 8.7 \times 10^{-10} \text{ s}$ $s = \frac{1}{2} \times \left( \frac{50 \text{ V} \times 1.6 \times 10^{-19} \text{ C}}{0.01 \text{ m} \times 9.11 \times 10^{-31} \text{ kg}} \right) \times (8.7 \times 10^{-10} \text{ s})^2$ $s = 3.3 \times 10^{-4} \text{ m}$	(6)

Question Number	Acceptable Answer	Additional guidance	Mark
(c)	<ul style="list-style-type: none"> <li>• use of <math>V = V_0 / \sqrt{2}</math> (1)</li> <li>• vertical line (1)</li> <li>• positive and negative deflection shown (1)</li> <li>• maximum deflection 75 V (1)</li> </ul>	<p><u>Example of calculation:</u></p> $V_0 = 53 \text{ V} \times \sqrt{2} = 75 \text{ V}$	(4)

Q9.

Question Number	Acceptable answers	Additional guidance				Mark																																
	<p>This question assesses a student's ability to show a coherent and logically structured answer with linkages and fully-sustained reasoning.</p> <p>Marks are awarded for indicative content and for how the answer is structured and shows lines of reasoning.</p> <p>The following table shows how the marks should be awarded for indicative content.</p> <p>Indicative content:</p> <p>IC1: set of (metal drift) tubes (in a line)</p> <p>IC2: electrons accelerated by electric field/potential difference</p> <p>IC3: acceleration takes place in the gaps between tubes</p> <p>IC4: adjacent tubes connected to opposite terminals of a power supply or opposite charge/polarity</p>	<table border="1"> <thead> <tr> <th>IC points</th> <th>IC mark</th> <th>Max linkage mark available</th> <th>Max final mark</th> </tr> </thead> <tbody> <tr> <td>6</td> <td>4</td> <td>2</td> <td>6</td> </tr> <tr> <td>5</td> <td>3</td> <td>2</td> <td>5</td> </tr> <tr> <td>4</td> <td>3</td> <td>1</td> <td>4</td> </tr> <tr> <td>3</td> <td>2</td> <td>1</td> <td>3</td> </tr> <tr> <td>2</td> <td>2</td> <td>0</td> <td>2</td> </tr> <tr> <td>1</td> <td>1</td> <td>0</td> <td>1</td> </tr> <tr> <td>0</td> <td>0</td> <td>0</td> <td>0</td> </tr> </tbody> </table>	IC points	IC mark	Max linkage mark available	Max final mark	6	4	2	6	5	3	2	5	4	3	1	4	3	2	1	3	2	2	0	2	1	1	0	1	0	0	0	0				6
IC points	IC mark	Max linkage mark available	Max final mark																																			
6	4	2	6																																			
5	3	2	5																																			
4	3	1	4																																			
3	2	1	3																																			
2	2	0	2																																			
1	1	0	1																																			
0	0	0	0																																			
	<p>IC5: power supply/p.d./electric field is alternating (so that as electron emerges from one tube the next tube is positive)</p> <p>IC6: time spent in each tube must be the same so as the electrons travel faster the tubes must</p>																																					
	be longer / gaps between get longer																																					

Q10.

Question Number	Acceptable answers	Additional guidance	Mark
	<ul style="list-style-type: none"> <li>High energy electrons will have a short (de Broglie) wavelength (1)</li> <li>The wavelength needs to be comparable/smaller than proton size (1)</li> </ul>		2

Q11.

Question Number	Acceptable answers	Additional guidance	Mark																												
*	<p>This question assesses a student's ability to show a coherent and logical structured answer with linkage and fully-sustained reasoning. Marks are awarded for indicative content and for how the answer is structured and shows lines of reasoning. The following table shows how the marks should be awarded for indicative content.</p> <table border="1"> <thead> <tr> <th>Number of indicative points seen in answer</th> <th>Number of marks awarded for indicative points</th> </tr> </thead> <tbody> <tr> <td>6</td> <td>4</td> </tr> <tr> <td>5-4</td> <td>3</td> </tr> <tr> <td>3-2</td> <td>2</td> </tr> <tr> <td>1</td> <td>1</td> </tr> <tr> <td>0</td> <td>0</td> </tr> </tbody> </table> <p><b>Indicative content</b></p> <ul style="list-style-type: none"> <li>• There is an alternating p.d./E-field</li> <li>• P.d./E-field accelerates protons between dees</li> <li>• Magnetic field perpendicular to plane of dees</li> <li>• Proton path curved by magnetic field</li> <li>• As velocity of protons increases radius of path in dees increases</li> <li>• The time for which a proton is in a dee remains constant Or the frequency of p.d./E-field is constant</li> </ul>	Number of indicative points seen in answer	Number of marks awarded for indicative points	6	4	5-4	3	3-2	2	1	1	0	0	<p>Guidance on how the mark scheme should be applied: The mark for The following table shows how the marks should be awarded for structure and lines of reasoning</p> <table border="1"> <thead> <tr> <th></th> <th>Number of marks awarded for structure and lines of reasoning</th> </tr> </thead> <tbody> <tr> <td>Answer shows a coherent and logical structure with linkage and fully sustained lines of reasoning demonstrated throughout</td> <td>2</td> </tr> <tr> <td>Answer is partially structured with some linkages and lines of reasoning</td> <td>1</td> </tr> <tr> <td>Answer has no linkage between points and is unstructured</td> <td>0</td> </tr> </tbody> </table> <table border="1"> <thead> <tr> <th>Number of IC points</th> <th>Possible linkage marks</th> </tr> </thead> <tbody> <tr> <td>0, 1</td> <td>0</td> </tr> <tr> <td>2, 3</td> <td>1</td> </tr> <tr> <td>4, 5, 6</td> <td>2</td> </tr> </tbody> </table> <p>IC2 accept 'in the gap' for between dees. Accept increases <math>E_k</math> for accelerates</p> <p>IC3 accept vertical or upwards for perpendicular to plane.</p> <p>IC5 accept reference to <math>r = p/BQ</math></p>		Number of marks awarded for structure and lines of reasoning	Answer shows a coherent and logical structure with linkage and fully sustained lines of reasoning demonstrated throughout	2	Answer is partially structured with some linkages and lines of reasoning	1	Answer has no linkage between points and is unstructured	0	Number of IC points	Possible linkage marks	0, 1	0	2, 3	1	4, 5, 6	2	6
Number of indicative points seen in answer	Number of marks awarded for indicative points																														
6	4																														
5-4	3																														
3-2	2																														
1	1																														
0	0																														
	Number of marks awarded for structure and lines of reasoning																														
Answer shows a coherent and logical structure with linkage and fully sustained lines of reasoning demonstrated throughout	2																														
Answer is partially structured with some linkages and lines of reasoning	1																														
Answer has no linkage between points and is unstructured	0																														
Number of IC points	Possible linkage marks																														
0, 1	0																														
2, 3	1																														
4, 5, 6	2																														

## Q12.

Question Number	Acceptable Answer	Additional guidance	Mark
<b>(a)</b>	<p>An explanation that makes reference to the following:</p> <ul style="list-style-type: none"> <li>• due to the large mass and speed <u>OR</u> large momentum <u>OR</u> large energy (1)</li> <li>• the alpha particle would have a large <u>change</u> in momentum when deflected through large angles which requires a large force (1)</li> </ul>		<b>(2)</b>

Question Number	Acceptable Answer	Additional guidance	Mark
<b>(b)</b>	<ul style="list-style-type: none"> <li>• use of <math>F = \frac{Q_1 Q_2}{4\pi\epsilon_0 r^2}</math> (1)</li> <li>• charge of alpha = <math>2 \times 1.6 \times 10^{-19}</math> (C) (1)</li> <li>• <math>r = 1.3 \times 10^{-13}</math> (m) (1)</li> <li>• comparison of the two distances (1)</li> <li>• conclusion that the alpha particle must reach a closer distance to give a larger force and relates this to the model (1)</li> </ul>	<p>Accept calculating a force for <math>r = 1.4 \times 10^{-10}</math> and comparing forces</p> <p><u>Example of calculation:</u></p> $r = \sqrt{8.99 \times 10^9 \text{ N m}^2 \text{C}^{-2} \times \frac{(79 \times 2)(1.6 \times 10^{-19} \text{ C})^2}{2}}$ <p><math>r = 1.3 \times 10^{-13} \text{ m}</math></p>	<b>(5)</b>



## Q13.

Question Number	Acceptable Answer	Additional guidance	Mark
	<p>An explanation that makes reference to the following points:</p> <p><u>Pion/ positron</u></p> <ul style="list-style-type: none"> <li>• radius decreasing (1) indicates speed/momentum is decreasing</li> <li>• smaller radius (1) indicates positron has smaller momentum than the pion</li> <li>• direction of deflection (1) indicates a positive charge by LH rule</li> </ul> <p><u>OR</u> compares direction of deflection between positron and pion to conclude they have the same charge</p> <p><u>Anti-muon</u></p> <ul style="list-style-type: none"> <li>• short path – short lived (1)</li> </ul>		<b>(6)</b>
	<ul style="list-style-type: none"> <li>• conservation of charge indicates it has same charge as pion (1)</li> </ul> <p><u>Muon neutrino OR electron neutrino</u></p> <ul style="list-style-type: none"> <li>• no path visible (1) indicates no charge</li> </ul>		

## Q14.

Question Number	Acceptable answers	Additional guidance	Mark
	<ul style="list-style-type: none"> <li>measures radius (allow between 4 cm and 6 cm) (1)</li> <li>Use of <math>p = Bqr</math> (1)</li> <li><math>B = 1.1</math> T (range 0.95 T – 1.42 T) (1)</li> <li>direction: out of page (1)</li> </ul>	Allow use of their measured radius in MP2 <u>Example of calculation:</u> $9.1 \times 10^{-20} \text{ N s} = B \times 1.6 \times 10^{-19} \text{ C} \times 0.52 \text{ m}$ $B = 1.09 \text{ T}$	4

## Q15.

Question Number	Acceptable answers	Additional guidance	Mark
	<ul style="list-style-type: none"> <li>The curved surface is (analogous to) a radial field (1)</li> <li>(as <math>h \propto 1/r</math> then) potential (energy) <math>\propto 1/r</math> (1)</li> <li>compares with <math>V \propto 1/r</math> around a point charge (1)</li> </ul>		3

## Q16.

Question Number	Acceptable answers	Additional guidance		Mark
	C	Most alpha particles go straight through.	The atom is mainly empty space.	1
	A the observation is incorrect B the observation is incorrect D the observation is correct but this is not the corresponding conclusion			

Q17.

Question Number	Acceptable answers	Additional guidance	Mark
	<p>The only correct answer is B</p> <p><i>A is not correct because a cyclotron uses a magnetic field</i></p> <p><i>C is not correct because a LINAC uses an electric field</i></p> <p><i>D is not correct because a LINAC does not use a magnetic field</i></p>	Cyclotron accelerated	1

Q18.

Question number	Acceptable answers	Additional guidance	Mark
	<p>An explanation that makes reference to:</p> <ul style="list-style-type: none"> <li>• Most alpha particles pass through undeflected (1) OR some deflected through a small angle (1)</li> <li>• A very small number are deflected through an angle greater than 90° (1)</li> <li>• This suggests that the alpha particles are deflected by a charged nucleus that has a very small diameter compared to that of the atom rather than the charge being distributed throughout the atom (1)</li> <li>• and that most of the mass of the atom is concentrated in the nucleus rather than distributed throughout the atom (1)</li> </ul>		4

Q19.

Question Number	Answer	Mark
	B	1

Q20.

Question Number	Acceptable Answer	Additional Guidance	Mark
	<p>An explanation that makes reference to the following points:</p> <ul style="list-style-type: none"> <li>• The potential difference creates an electric field (1)</li> <li>• An (electric) field/force does work on the electrons (increasing their kinetic energy) Or an (electric) field/force accelerates the electrons (increasing their velocity) (1)</li> </ul>		2