

## Electric Fields

Q1.

The graph shows how the potential  $V$  varies with distance  $d$  in an electric field.

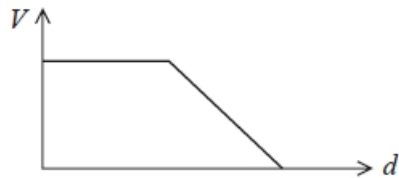

Which of the following shows the corresponding variation in electric field strength  $E$ ?

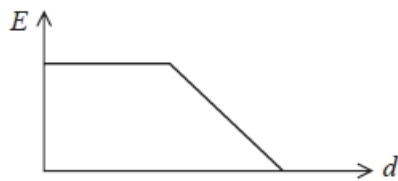

A

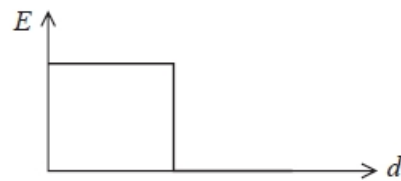

B

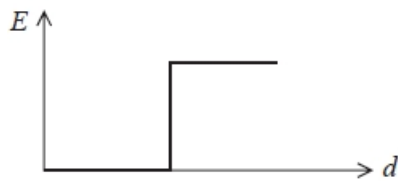

C

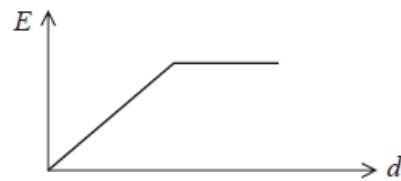

D

(Total for question = 1 mark)

**Q2.**

A point object has a charge +Q.

Which of the following diagrams shows equipotential lines differing by a constant potential difference, and electric field lines around the object?

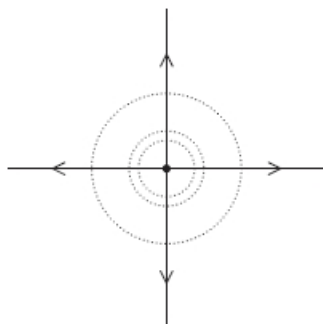
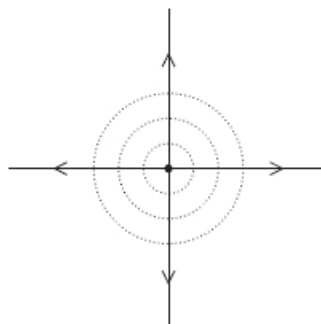
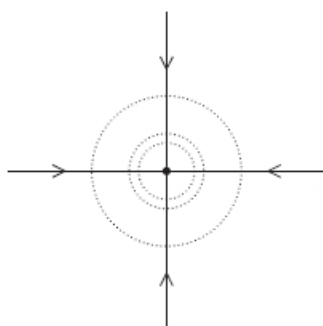
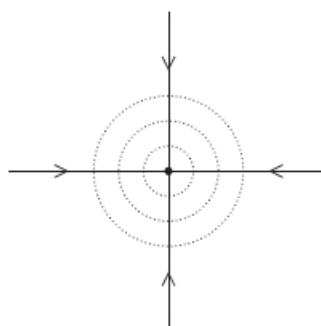
 **A**

 **B**

 **C**

 **D**

**(Total for question = 1 mark)**

**Q3.**

What is the acceleration of an electron at a point in an electric field where the electric field strength is  $2.0 \times 10^4 \text{ N C}^{-1}$ ?

- A**  $2.8 \times 10^{-16} \text{ m s}^{-2}$
- B**  $3.2 \times 10^{-15} \text{ m s}^{-2}$
- C**  $1.8 \times 10^{11} \text{ m s}^{-2}$
- D**  $3.5 \times 10^{15} \text{ m s}^{-2}$

**(Total for question = 1 mark)**

**Q4.**

In an experiment to determine the charge on an electron, negatively charged oil drops are allowed to fall between two parallel metal plates separated by a distance  $d$ .

A potential difference (p.d.) is applied across the plates. The diagram shows one oil drop between the plates.

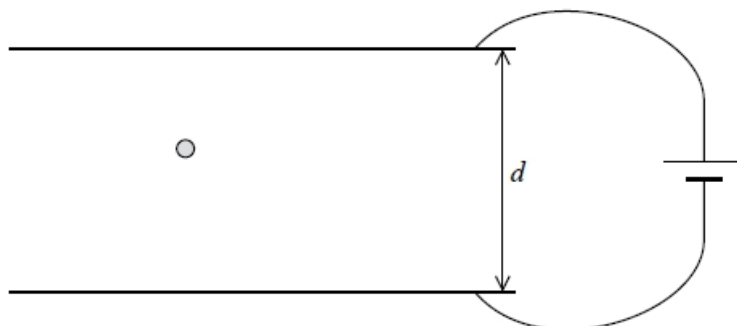

When the p.d. is 0 V the oil drop accelerates to terminal velocity. The p.d. is increased. It is observed that at a particular p.d.  $V$  the oil drop stops falling and remains stationary between the plates.

\* Explain the motion of the oil drop in terms of the forces acting on it as the p.d. is increased from 0 to  $V$ .

(6)

.....

.....

.....

.....

.....

.....

.....

.....

.....

.....

.....

.....

.....

.....

.....

.....

.....

.....

.....

.....

.....

.....

**(Total for question = 6 marks)**

**Q5.**

In an experiment to determine the charge on an electron, negatively charged oil drops are allowed to fall between two parallel metal plates separated by a distance  $d$ .

A potential difference (p.d.) is applied across the plates. The diagram shows one oil drop between the plates.

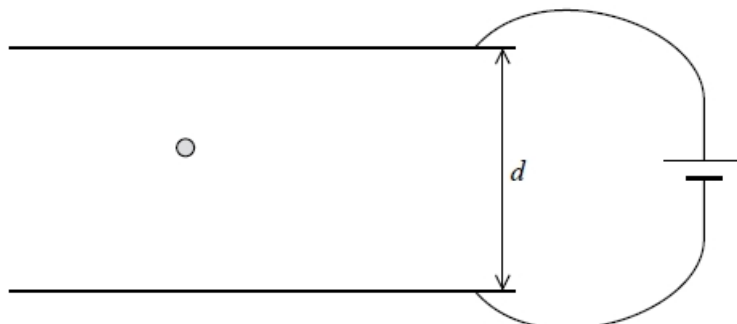

When the p.d. is 0 V the oil drop accelerates to terminal velocity. The p.d. is increased. It is observed that at a particular p.d.  $V$  the oil drop stops falling and remains stationary between the plates.

(a) The oil drop has a mass  $m$ . Show that the charge  $q$  on the oil drop is given by

$$q = \frac{mgd}{V}$$

(2)

.....

.....

.....

(b) Explain what would happen to the oil drop if the p.d. is increased further.

(2)

.....

.....

.....

.....

**(Total for question = 4 marks)**

**Q6.**

Some flowers are negatively charged and surrounded by an electric field. This helps to attract bees.

State what is meant by an electric field.

(1)

.....

.....

**(Total for question = 1 mark)**

**Q7.**

Sketch the electric field around a positive point charge.

(3)



**(Total for question = 3 marks)**

**Q8.**

Some flowers are negatively charged and surrounded by an electric field. This helps to attract bees.

When the bee is collecting nectar from the plant, the electric field strength decreases. It is thought that this warns other bees that the nectar supply is low.

State the effect of a decreased electric field strength on the equipotential lines.

(1)

.....

.....

**(Total for question = 1 mark)****Q9.**

Some flowers are negatively charged and surrounded by an electric field. This helps to attract bees.

The diagram shows lines of equipotential surrounding a flower.

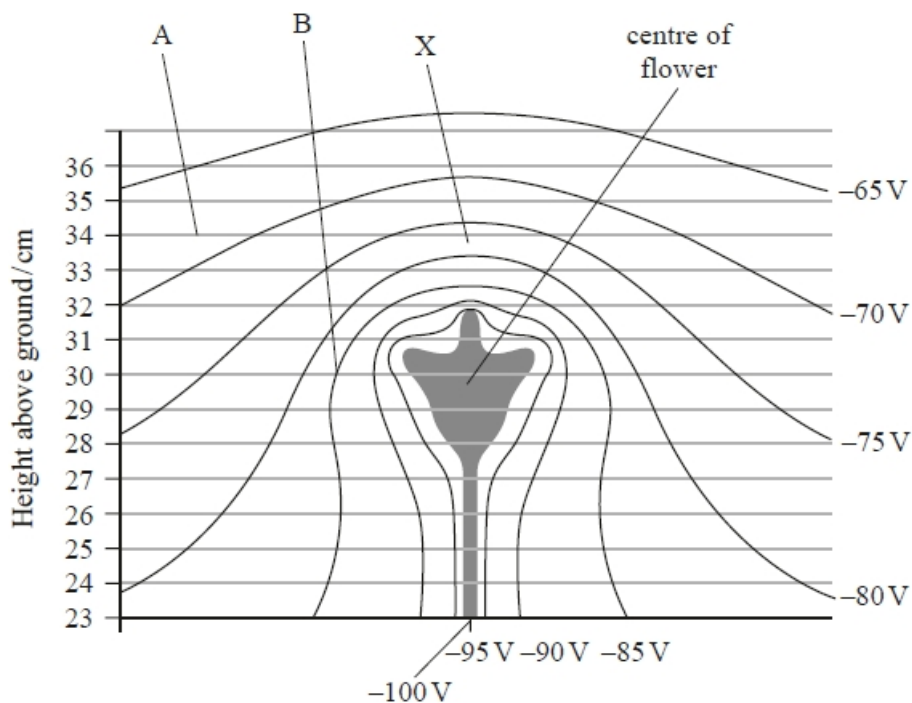

(i) Determine the electric field strength at X.

(3)

.....

.....

.....

.....

.....

.....

Electric field strength at X = .....

(ii) Draw the electric field line between point A and point B on the diagram.

(2)

(iii) An equation for electric potential  $V$  is

$$V = \frac{Q}{4\pi\epsilon_0 r}$$

This applies to a radial field.

Deduce whether the electric field in the region directly above the flower is radial.

You should take values from the diagram. A graphical method is not required.

(3)

.....

.....

.....

.....

.....

.....

.....

**(Total for question = 8 marks)**

**Q10.**

A potential difference is applied across two parallel plates. A particle carrying a charge of  $+0.1\text{ C}$  is placed between the plates and experiences a force  $F$ .

The distance between the plates is halved. The potential difference remains constant.

Which of the following is now equal to the electric field strength between the plates?

- A  $5F$
- B  $10F$
- C  $20F$
- D  $40F$

**(Total for question = 1 mark)**

**Q11.**

13 The diagram shows two parallel metal plates with a potential difference (p.d.) of  $100\text{ V}$  across them. Three equipotential lines are shown.

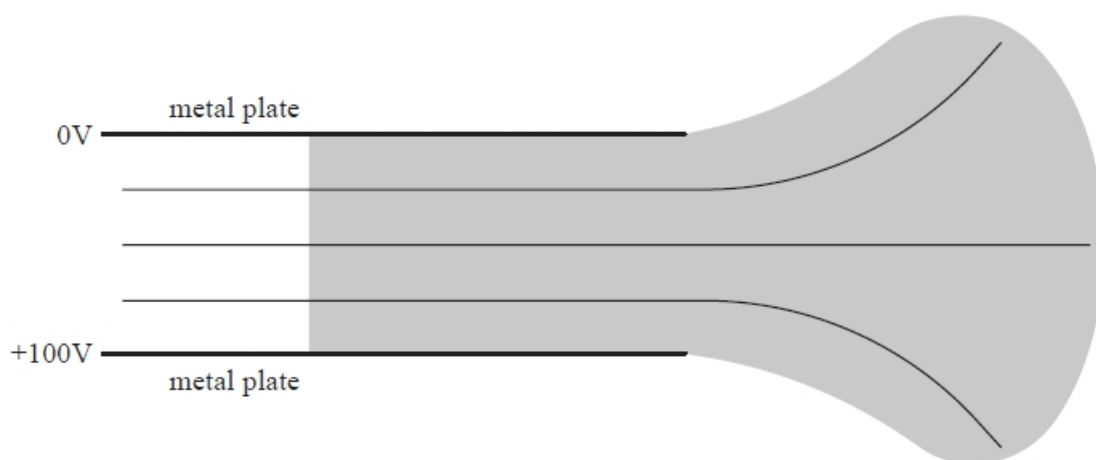

Draw lines to represent the electric field in the shaded area.

**(4)**

**(Total for question = 4 marks)**



**Q12.**

The graph shows how an electric potential  $V$  varies with distance  $x$ .

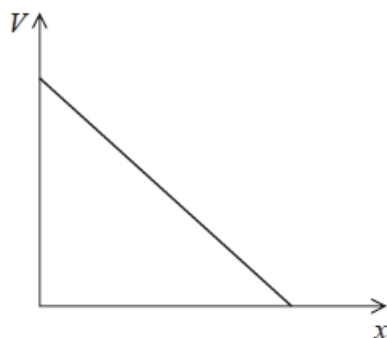

Which of the following shows the corresponding variation of electric field strength  $E$  with  $x$ ?

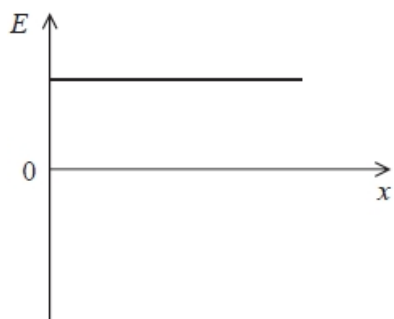
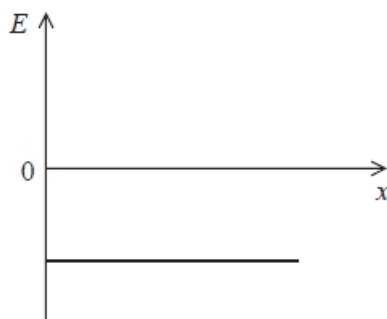
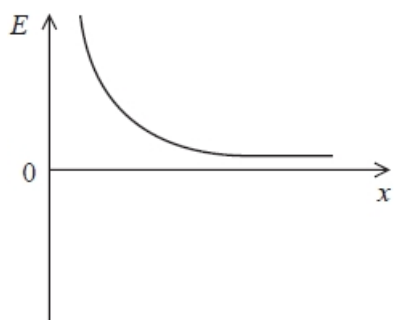
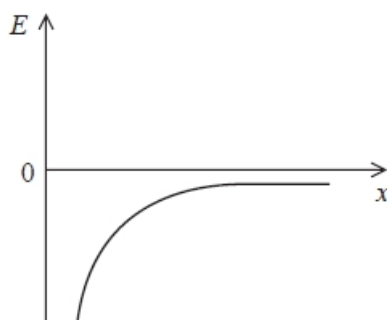
 A B C D

(Total for question = 1 mark)

**Q13.**

A potential difference  $V$  is applied across two parallel plates. An electron midway between the two plates at point X experiences an electric force  $F$ .

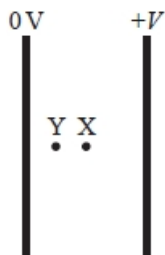

The electron moves to point Y which is halfway between point X and the left-hand plate.

Which of the following is the electric force experienced by the electron at Y?

- A  $2F$
- B  $F$
- C  $\frac{F}{2}$
- D  $\frac{F}{4}$

(Total for question = 1 mark)

**Q14.**

The distance between a proton and an electron is  $r$ . The electrostatic force is  $F$ .

The distance between the proton and electron is doubled.

Which of the following is equal to the electrostatic force at this separation?

- A  $2F$
- B  $\frac{F}{2}$
- C  $\frac{F}{3}$
- D  $\frac{F}{4}$

(Total for question = 1 mark)

**Q15.**

The force between two identical point charges, X and Y, is  $F$ .

Charge X is doubled; charge Y remains the same.

Which row of the table gives the force on each charge?

	X	Y
<input type="checkbox"/> A	$F$	$F$
<input type="checkbox"/> B	$F$	$2F$
<input type="checkbox"/> C	$2F$	$F$
<input type="checkbox"/> D	$2F$	$2F$

**(Total for question = 1 mark)**

**Q16.**

A simple model of the hydrogen atom consists of an electron moving in a circular path around a proton.

(i) In this simple model it is the electrostatic force, rather than the gravitational force, that is responsible for keeping the electron in a circular path.

By means of calculations justify this statement.

radius  $r$  of the hydrogen atom =  $5.3 \times 10^{-11}$  m

**(4)**

.....

.....

.....

.....

.....

(ii) Ignoring the gravitational force, calculate the velocity of the electron in this simple model of the hydrogen atom.

**(3)**

.....

.....

.....

.....

Velocity = .....

**(Total for question = 7 marks)**

**Q17.**

Some flowers are negatively charged and surrounded by an electric field. This helps to attract bees.

A bee has short hairs which are thought to carry charge.

State how the bee might use this to detect the electric field of a flower.

(1)

.....

.....

**(Total for question = 1 mark)**

**Q18.**

The graph shows how potential varies with distance from the centre of a charged sphere.

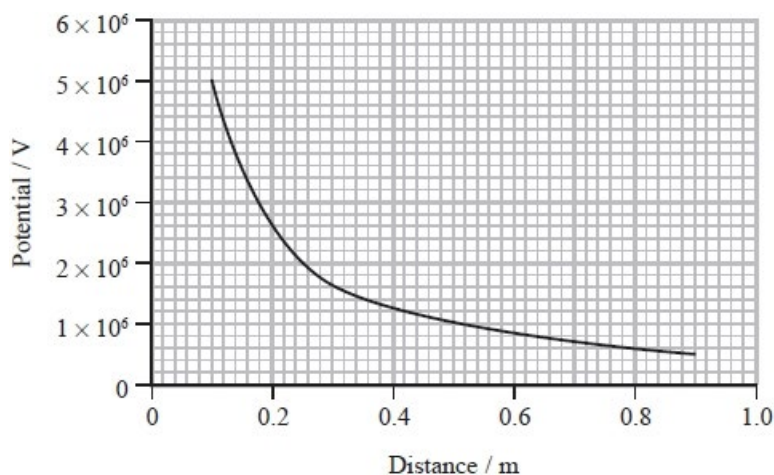

Air molecules will be ionised if the electric field strength exceeds  $3 \times 10^6 \text{ V m}^{-1}$ .

Deduce whether air molecules will be ionised at a distance of 30 cm from the centre of this sphere.

(4)

.....

.....

.....

.....

.....

.....

**(Total for question = 4 marks)**

**Q19.**

The photograph shows a statue of Buddha in Sri Lanka, which is protected by a lightning conductor.



© Valery Shanin/123RF

Give a reason why the lightning conductor should be taller than the statue.

(1)

.....

.....

**(Total for question = 1 mark)**

**Q20.**

Two small spheres L and M are attached to non-conducting threads and suspended from a point P. Each sphere is given an equal positive charge of  $4.0 \times 10^{-7}$  C. The spheres hang in equilibrium as shown in the diagram.

The mass of each sphere is 2.7 g.

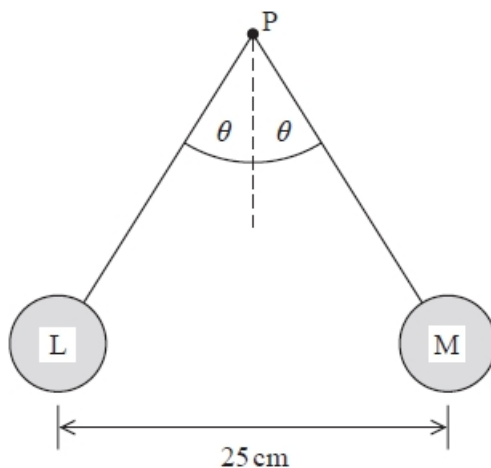

By considering the forces acting on one of the spheres, calculate the tension in the thread and the angle  $\theta$ .

(6)

.....

.....

.....

.....

.....

.....

.....

.....

.....

.....

.....

.....

.....

Tension = .....

$\theta$  = .....

## Mark Scheme - Electric Fields

Q1.

Question Number	Acceptable answers	Additional guidance	Mark
	<b>The only correct answer is C</b>		<b>1</b>
	<i>A is not correct because the E is equal to - gradient of the graph of V against r B is not correct because the E is equal to - gradient of the graph of V against r D is not correct because the E is equal to - gradient of the graph of V against r</i>		

Q2.

Question Number	Acceptable answers	Additional guidance	Mark
	<b>The only correct answer is A</b>		<b>1</b>
	<i>B is not correct because field direction is correct but equipotential lines will become further apart as distance increases as <math>V \propto 1/r</math> C is not correct because field direction is incorrect D is not correct because field direction is incorrect</i>		

Q3.

Question Number	Answer	Mark
	D	<b>1</b>

## Q4.

Question number	Acceptable answers	Additional guidance	Mark												
*	<p>This question assesses a student's ability to show a coherent and logically structured answer with linkages and fully-sustained reasoning.</p> <p>Marks are awarded for indicative content and for how the answer is structured and shows lines of reasoning.</p> <p>The following table shows how the marks should be awarded for indicative content.</p> <table border="1"> <thead> <tr> <th>Number of indicative marking points seen in answer</th> <th>Number of marks awarded for indicative marking points</th> </tr> </thead> <tbody> <tr> <td>6</td> <td>4</td> </tr> <tr> <td>5-4</td> <td>3</td> </tr> <tr> <td>3-2</td> <td>2</td> </tr> <tr> <td>1</td> <td>1</td> </tr> <tr> <td>0</td> <td>0</td> </tr> </tbody> </table>	Number of indicative marking points seen in answer	Number of marks awarded for indicative marking points	6	4	5-4	3	3-2	2	1	1	0	0	<p>Guidance on how the mark scheme should be applied:</p> <p>The mark for indicative content should be added to the mark for lines of reasoning. For example, an answer with five indicative marking points which is partially structured with some linkages and lines of reasoning scores 4 marks (3 marks for indicative content and 1 mark for partial structure and some linkages and lines of reasoning).</p> <p>If there are no linkages between points, the same five indicative marking points would yield an overall score of 3 marks (3 marks for indicative content and no marks for linkages).</p>	
Number of indicative marking points seen in answer	Number of marks awarded for indicative marking points														
6	4														
5-4	3														
3-2	2														
1	1														
0	0														

Question number	Acceptable answers	Additional guidance	Mark								
* (continued)	<p>The following table shows how the marks should be awarded for structure and lines of reasoning.</p> <table border="1"> <thead> <tr> <th></th> <th>Number of marks awarded for structure of answer and sustained line of reasoning</th> </tr> </thead> <tbody> <tr> <td>Answer shows a coherent and logical structure with linkages and fully sustained lines of reasoning demonstrated throughout</td> <td>2</td> </tr> <tr> <td>Answer is partially structured with some linkages and lines of reasoning</td> <td>1</td> </tr> <tr> <td>Answer has no linkages between points and is unstructured</td> <td>0</td> </tr> </tbody> </table>		Number of marks awarded for structure of answer and sustained line of reasoning	Answer shows a coherent and logical structure with linkages and fully sustained lines of reasoning demonstrated throughout	2	Answer is partially structured with some linkages and lines of reasoning	1	Answer has no linkages between points and is unstructured	0		
	Number of marks awarded for structure of answer and sustained line of reasoning										
Answer shows a coherent and logical structure with linkages and fully sustained lines of reasoning demonstrated throughout	2										
Answer is partially structured with some linkages and lines of reasoning	1										
Answer has no linkages between points and is unstructured	0										



Question number	Acceptable answers	Additional guidance	Mark
* (continued)	<p><b>Indicative content</b></p> <ul style="list-style-type: none"> <li>At terminal velocity the forces on the drop are balanced <b>OR</b> weight = drag</li> <li>The p.d. creates an electrostatic force acting upwards on the drop</li> <li>The electrostatic force increases as p.d. increases</li> <li>The net upward force causes the drop to have a negative acceleration</li> <li>As speed decreases the drag decreases</li> <li>The drop remains stationary when the forces are balanced <b>OR</b> until the drop remains stationary when weight = electrostatic force</li> </ul>		6

## Q5.

Question number	Acceptable answers	Additional guidance	Mark
(b)	<ul style="list-style-type: none"> <li>Equate the electric force and the gravitational force <b>(1)</b></li> <li>Use of <math>E=V/d</math> to obtain <math>q = mgd/V</math> <b>(1)</b></li> </ul>	$qE = mg$ $q(V/d) = mg$ $q = mgd/V$	2
(c)	<p>An explanation that makes reference to:</p> <ul style="list-style-type: none"> <li>Electrostatic/upward force (on drop) would be greater than the weight/downward force <b>(1)</b></li> <li>So drop would <u>accelerate</u> upwards <b>(1)</b></li> </ul>	Indication of which force is greater, unbalanced is insufficient.	2

## Q6.

Question Number	Acceptable answers	Additional guidance	Mark
	<ul style="list-style-type: none"> <li>A region where a charged particle experiences a force/acceleration <b>(1)</b></li> </ul>		<b>(1)</b>

## Q7.

Question number	Acceptable Answers	Additional guidance	Mark
	<ul style="list-style-type: none"> <li>At least 4 radial lines <b>(1)</b></li> <li>arrow pointing outwards <b>(1)</b></li> <li>straight, symmetrical and equally distributed <b>(1)</b></li> </ul>	Ignore dotted lines	3

Q8.

Question Number	Acceptable answers	Additional guidance	Mark
	<ul style="list-style-type: none"> <li>Equipotential lines would be further apart</li> </ul>	(1)	(1)

Q9.

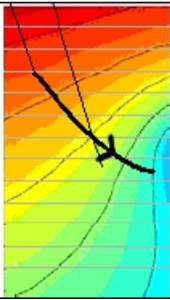
Question Number	Acceptable answers	Additional guidance	Mark
(i)	<ul style="list-style-type: none"> <li>States a value of <math>\Delta V</math></li> <li>Uses <math>\Delta V/\Delta d</math> with a difference in distance</li> <li><math>E = 560 \text{ V m}^{-1}</math> allow range 500-560 <math>\text{V m}^{-1}</math></li> </ul>	(1) (1) (1) Example of calculation: $E = \frac{(80-75)\text{V}}{0.009\text{m}} = 556 \text{ V m}^{-1}$ (Alt: $5.6 \text{ V cm}^{-1}$ )	(3)
(ii)	<ul style="list-style-type: none"> <li>Line perpendicular to a least 2 equipotential lines</li> <li>Arrow pointing towards flower</li> </ul>	(1) (1) 	(2)
(iii)	<ul style="list-style-type: none"> <li>States <math>V \times r = \text{constant}</math></li> <li>One corresponding pair of values of <math>V</math> and <math>r</math></li> <li>At least two pairs of values used to show that the product is not constant therefore not radial (MP3 dependent on MP2)</li> </ul>	(1) (1) (1) Example of calculation: Using $V = 95$ and $r = 2.0 - 2.2$ : $Vr = 190 - 209$ $V = 90$ and $r = 2.1 - 2.5$ : $Vr = 189 - 225$ $V = 85$ and $r = 2.5 - 2.8$ : $Vr = 212 - 238$ $V = 80$ and $r = 3.5 - 3.8$ : $Vr = 280 - 304$ $V = 75$ and $r = 4.3 - 4.7$ : $Vr = 323 - 353$ $V = 70$ and $r = 5.8 - 6.2$ : $Vr = 406 - 434$ Using $r = 3$ and $V = 82-83$ : $Vr = 246-249$ $r = 4$ and $V = 77-78$ : $Vr = 308-312$ $r = 5$ and $V = 72-73$ : $Vr = 360-365$	(3)

Q10.

Question Number	Acceptable answers	Additional guidance	Mark
	<p>The only correct answer is C</p> <p>A is not correct as <math>E_{\text{initial}} = F/Q = 10F</math>, if <math>d</math> halved then <math>E_{\text{after}} = 20F</math></p> <p>B is not correct as <math>E_{\text{initial}} = F/Q = 10F</math>, if <math>d</math> halved then <math>E_{\text{after}} = 20F</math></p> <p>D is not correct as <math>E_{\text{initial}} = F/Q = 10F</math>, if <math>d</math> halved then <math>E_{\text{after}} = 20F</math></p>		1

Q11.

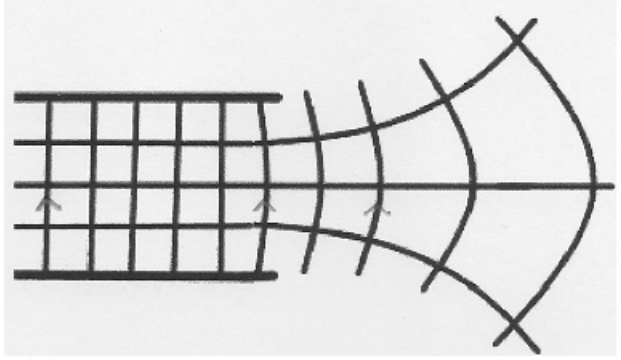
Question Number	Acceptable answers	Additional guidance	Mark
	<ul style="list-style-type: none"> <li>• Arrow upwards on at least one line. (1)</li> </ul> <p>Uniform section:</p> <ul style="list-style-type: none"> <li>• at least 3 parallel, perpendicular straight lines, equispaced (1)</li> </ul> <p>Non-uniform:</p> <ul style="list-style-type: none"> <li>• at least 2 lines perpendicular to equipotentials (1)</li> <li>• spacing getting larger (1)</li> </ul>		4

Q12.

Question Number	Acceptable answers	Additional guidance	Mark
	<p>The only correct answer is A</p> 	B, C and D are not the negative potential gradient	1

Q13.

Question Number	Acceptable answers	Additional guidance	Mark
	<p>The only correct answer is B</p> <p><i>A is not correct because this is a uniform field so F constant</i></p> <p><i>C is not correct because this is a uniform field so F constant</i></p> <p><i>D is not correct because this is a uniform field so F constant</i></p>	<i>F</i>	1

Q14.

Question Number	Acceptable answers	Additional guidance	Mark
	The only correct answer is D $\frac{F}{4}$	A,B and C do not show an inverse square	1

Q15.

Question Number	Acceptable answers	Additional guidance	Mark
	D		1

Q16.

Question number	Acceptable answers	Additional guidance	Mark
(i)	<ul style="list-style-type: none"> <li>• use of <math>F = Q_1Q_2/4\pi\epsilon_0r^2</math> (1)</li> <li>• use of <math>F = Gm_1m_2/r^2</math> (1)</li> <li>• Expresses forces as a ratio (1) OR calculates the individual forces <math>F_e=8.1 \times 10^{-8} \text{ N}</math> <math>F_g = 3.6 \times 10^{-47} \text{ N}</math> (1)</li> <li>• Ratio = <math>2 \times 10^{39}</math> or <math>5 \times 10^{40}</math> and identifies gravitational force as insignificant (1)</li> </ul>		4
(ii)	<ul style="list-style-type: none"> <li>• use of <math>F = mv^2/r</math> and <math>F = Q_1Q_2/4\pi\epsilon_0r^2</math> (1)</li> <li>• to derive <math>v = \sqrt{\frac{Q_1Q_2}{4\pi\epsilon_0rm}}</math> (1)</li> <li>• velocity = <math>2.2 \times 10^6 \text{ m s}^{-1}</math> (1)</li> </ul>	Example of calculation: $v = \sqrt{\frac{Q_1Q_2}{4\pi\epsilon_0rm}}$ $v = \sqrt{\frac{1.6 \times 10^{-19} \text{ C} \times 1.6 \times 10^{-19} \text{ C}}{4\pi \times 8.85 \times 10^{-12} \text{ Fm}^{-1} \times 5.3 \times 10^{-11} \text{ m} \times 9.1 \times 10^{-31} \text{ kg}}}$ $v = 2.185 \times 10^6 \text{ m s}^{-1}$	3

Q17.

Question Number	Acceptable answers	Additional guidance	Mark
	<ul style="list-style-type: none"> <li>• Charged particle/hair attracts/repels (1)</li> </ul> Or charged/hair experiences a force		(1)

Q18.

Question Number	Acceptable Answers	Additional guidance	Mark
	<ul style="list-style-type: none"> <li>tangent at correct point (1)</li> <li>triangle with base at least 0.4 m (1)</li> <li><math>5.3 \times 10^6 \text{ (Vm}^{-1}\text{)}</math> (range <math>4.9 \times 10^6</math> to <math>6.1 \times 10^6</math>) (1)</li> <li>So would ionise as value greater than <math>3 \times 10^6</math> (1)</li> </ul> <p>Alternative:</p> <ul style="list-style-type: none"> <li>Correct value of <math>V</math> at 30 cm (1)</li> <li>Use of <math>E = k \frac{Q}{r^2}</math> and <math>V = k \frac{Q}{r}</math> (1)</li> <li><math>5.3 \times 10^6 \text{ (Vm}^{-1}\text{)}</math> (1)</li> <li>So would ionise as value greater than <math>3 \times 10^6</math> (1)</li> </ul>	<p>Example of calculation:</p> <p>Gradient = <math>3200000 / 0.6</math></p> <p><math>E = 5.3 \times 10^6 \text{ V m}^{-1}</math></p> <p>MP4 to be consistent with calculated value</p> <p><math>V = 1.6 \times 10^6 \text{ V m}^{-1}</math></p>	4

Q19.

Question Number	Acceptable Answer	Additional Guidance	Mark
	<ul style="list-style-type: none"> <li>So that the lightning makes contact with the conductor rather than the statue (1)</li> </ul>		1

Q20.

Question Number	Answer	Mark
	Use of $F_E = kQ_1Q_2/r^2$	(1)
	Use of $W = mg$	(1)
	Resolve vertically $T \cos \theta = mg$ and Resolve horizontally $T \sin \theta = F_E$	(1)
	Attempt to combine components to give $\tan \theta$ ( $\tan \theta = F_E/mg$ )	(1)
	$\theta = 41^\circ$ to $42^\circ$	(1)
	$T = 0.035$ N	(1)
	<b>Or</b>	
	Use of $F_E = kQ_1Q_2/r^2$	(1)
	Use of $W = mg$	(1)
	Use of Pythagoras to find tension force	(1)
	$\tan \theta = F_E/mg$ Or $\cos \theta = mg/T$ Or $\sin \theta = F_E/T$	(1)
	$\theta = 41^\circ$ to $42^\circ$	(1)
	$T = 0.035$ N	(1)
	(if they halve the separation or halve the electric force they can still get MP1 and so could score MP1,2, 3 & 4 )	
	<u>Example of calculation</u>	
	Weight of sphere = $0.0027 \text{ kg} \times 9.81 \text{ N kg}^{-1} = 0.026 \text{ N}$	
	Electric force $F_E = kQ_1Q_2/r^2$	
	$= 8.99 \times 10^9 \text{ N m}^2 \text{ C}^{-2} \times (4.0 \times 10^{-7} \text{ C})^2 / 0.25^2 \text{ m}^2 = 0.023 \text{ N}$	
	Vertically $T \cos \theta = mg$	
	Horizontally $T \sin \theta = F_E$	
	$\tan \theta = F_E/mg = 0.023 \text{ N} / 0.026 \text{ N}$	
	$\theta = 41^\circ$	
	sub into vertical equation	
	$T = mg / \cos \theta = 0.026 \text{ N} / \cos 41$	
	$T = 0.034 \text{ N}$	
		6