

## Particle Nature of Light and The Wave-Particle Duality

### Q1.

In 1905 Einstein published his equation for the photoelectric effect.

In 1916 Millikan demonstrated that the maximum kinetic energy of photoelectrons is consistent with Einstein's equation.

Millikan's experiments involved using different frequencies of light. These were obtained using a mercury vapour lamp which produced an emission spectrum with a specific number of known frequencies.

The diagram shows some energy levels for a mercury atom.

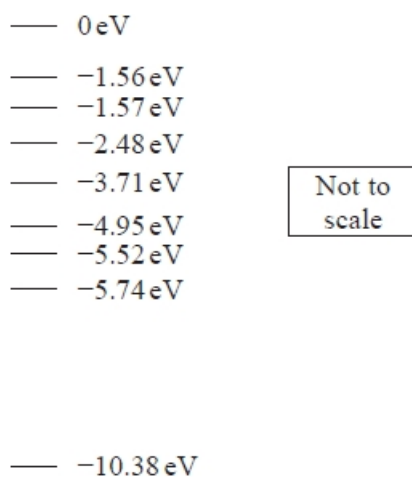

Determine which transition from the  $-3.71$  eV energy level would produce light of wavelength  $6.1 \times 10^{-7}$  m.

(4)

.....

.....

.....

.....

.....

.....

.....

.....

.....

.....

Transition from  $-3.71$  eV to .....

**(Total for question = 4 marks)**

**Q2.**

In a model of a hydrogen atom, it is assumed that the electron behaves like a wave with a de Broglie wavelength  $\lambda$ . The wave associated with the electron forms a standing wave whose wavelength is equal to the circumference of the circular path.

Calculate the velocity of the electron based on this model.

(3)

.....

.....

.....

.....

.....

Velocity = .....

**(Total for question = 3 marks)**

**Q3.**

Which of the following is the SI base unit for the Planck constant?

- A**  $\text{N m}^{-1} \text{s}^{-1}$
- B**  $\text{N m s}$
- C**  $\text{kg m}^2 \text{s}^{-1}$
- D**  $\text{kg m}^{-2} \text{s}$

**(Total for question = 1 mark)**

**Q4.**

Radiation of frequency  $f$  and wavelength  $\lambda$  is emitted when an electron falls from energy level  $E_2$  to energy level  $E_1$ .

$E_2 - E_1$  is equal to

- A  $\frac{hc}{f}$
- B  $\frac{hc}{\lambda}$
- C  $\frac{hf}{c}$
- D  $\frac{h\lambda}{c}$

**(Total for question = 1 mark)**

**Q5.**

In 1990, the Hubble Space Telescope (HST) was launched into a low Earth orbit above the Earth's atmosphere.

The transmission of electromagnetic radiation through the atmosphere is shown on the graph.

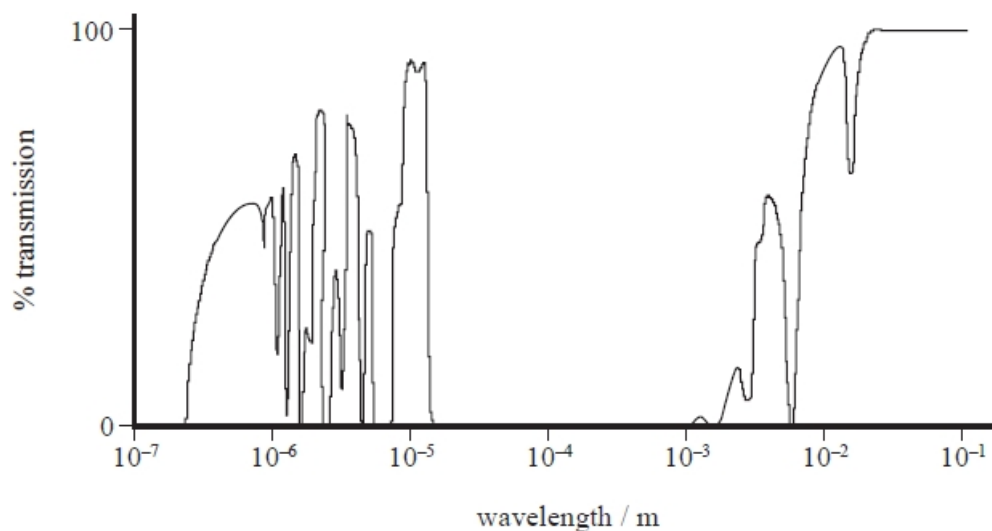

State one advantage shown by this graph of positioning a telescope above the atmosphere.

**(1)**

.....

.....

**(Total for question = 1 mark)**

**Q6.**

The Planck constant is an important universal constant used in the study of wave-particle duality.

In a demonstration of the photoelectric effect, ultraviolet radiation with a frequency of  $2.8 \times 10^{16}$  Hz is incident on the surface of clean zinc. Electrons are released from the surface of the zinc.

Calculate the maximum velocity of the released electrons.

work function of zinc =  $6.9 \times 10^{-19}$  J

(2)

.....

.....

.....

.....

.....

.....

Maximum velocity = .....

**(Total for question = 2 marks)**

**Q7.**

The idea of energy quantisation was used to explain the photoelectric effect, first observed by Heinrich Hertz.

When ultraviolet radiation is shone onto a metal surface, electrons may be released. A cadmium surface is illuminated with light of wavelength  $2.54 \times 10^{-7}$  m.

Calculate the maximum kinetic energy of the photoelectrons released from the surface.

Work function of cadmium = 4.07 eV

(4)

.....

.....

.....

.....

.....

.....  
 .....  
 .....

Maximum kinetic energy = ..... J

**(Total for question = 4 marks)**

**Q8.**

An optical microscope uses a beam of visible light. An electron microscope uses a beam of electrons.

A biologist looked at an animal cell using both microscopes. The two images are shown; both have the same magnification.

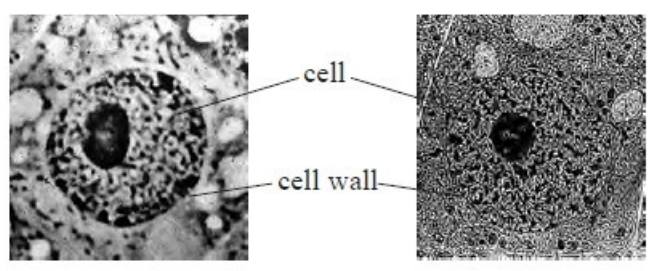

using optical microscope

using electron microscope

www.udel.edu

An electron in the beam of the electron microscope has a velocity of 2% of the speed of light. Calculate the de Broglie wavelength of the electron.

**(3)**

.....  
 .....  
 .....  
 .....  
 .....

de Broglie wavelength = .....

**(Total for question = 3 marks)**

**Q9.**

\* The behaviour of electromagnetic radiation can be described in terms of a photon model or a wave model.

In the photoelectric effect, electromagnetic radiation is incident on a metal plate and under certain conditions electrons are emitted.

It is observed that, for a given metal,

- no electrons are emitted if the frequency of the incident radiation is below a certain threshold frequency.
- electrons are emitted instantaneously if the frequency of the incident radiation is above a certain threshold frequency.
- the kinetic energy of the emitted electrons depends only on the frequency of the incident radiation.

Discuss how the photon model of electromagnetic radiation can explain these observations and why the wave model of electromagnetic radiation cannot.

(6)

.....

.....

.....

.....

.....

.....

.....

.....

.....

.....

.....

.....

.....

.....

.....

.....

.....

.....

.....

.....

.....

.....

.....

**(Total for question = 6 marks)**

**Q10.**

When the light from a star is dispersed to form a spectrum, dark lines are seen at a number of frequencies. This is known as an absorption spectrum and is caused by the presence of certain elements in the star.

Explain how the absorption spectrum is created.

(3)

.....

.....

.....

.....

.....

.....

.....

.....

.....

**(Total for question = 3 marks)**

**Q11.**

Read the following extract and then answer the questions that follow.

Powdery dust, the by-product of fearsome meteor storms that pounded the Moon, coats much of the lunar surface. A build-up of this dust could damage sensitive machinery.

Scientists theorise that lunar dust must be electrostatically charged by ultraviolet solar radiation from the Sun. When ultraviolet radiation hits the Moon's "day side", the half that faces the Sun, it knocks electrons out of atoms in the lunar soil.

(a) Describe the particle model of ultraviolet radiation that explains how it can "knock electrons out of atoms".

(3)

.....

.....

.....

.....

.....





(ii) The potential difference on the voltmeter is increased until the ammeter reading is zero.

The voltmeter reads 0.6 V at this instant.

State the maximum kinetic energy of the electrons in eV.

(1)

Maximum kinetic energy = ..... eV

(c) Discuss whether the photocell arrangement in part (b) gives a valid demonstration of how dust particles become charged on the Moon.

(4)

.....

.....

.....

.....

.....

.....

.....

.....

.....

.....

.....

.....

.....

.....

.....

.....

.....

**(Total for question = 11 marks)**

**Q12.**

In an investigation of the photoelectric effect, a metal plate is illuminated with light of different frequencies.

The graph shows the maximum kinetic energy of emitted electrons at different frequencies.

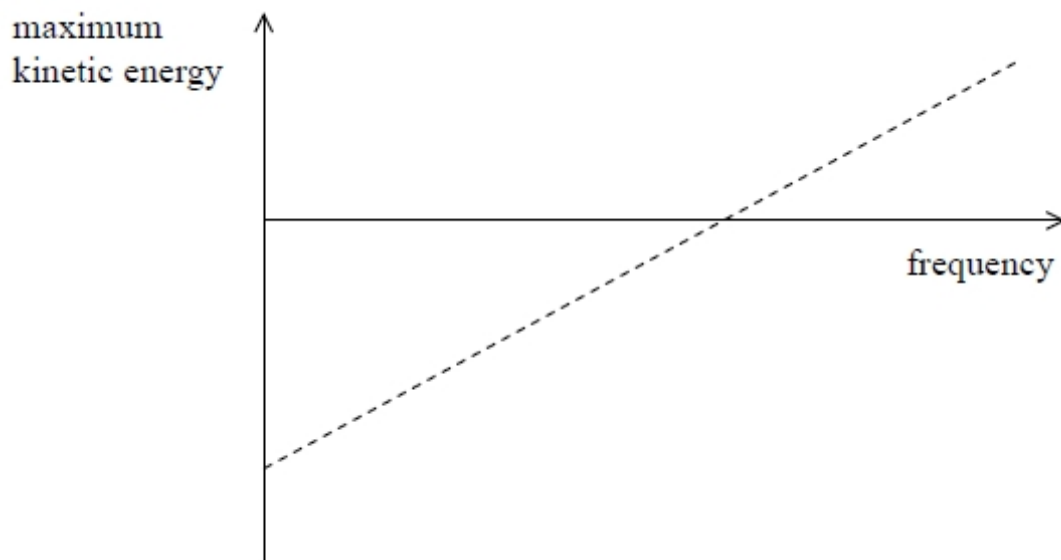

Which line of the table correctly shows the values given by the graph?

	<b><math>x</math> intercept</b>	<b>negative <math>y</math> intercept</b>
<input type="checkbox"/> A	Planck constant	work function
<input type="checkbox"/> B	threshold frequency	Planck constant
<input type="checkbox"/> C	threshold frequency	work function
<input type="checkbox"/> D	work function	threshold frequency

**(Total for question = 1 mark)**

**Q13.**

Read the passage and answer the question that follows.

Atoms can be promoted into an excited state when they absorb energy. This results in the release of radiation at a random time. When several atoms are close together a quantum effect can occur. When one atom emits radiation this affects all the other nearby excited atoms. The excess energy of many of the atoms is released simultaneously and an intense flash of light is produced. This effect is called superradiance and can be used to produce lasers that emit a narrower range of frequencies than conventional lasers.

Superradiance occurs when the distance between atoms is less than the wavelength of the emitted radiation.

An atom is in the ground state. The atom absorbs 6.2 eV of energy. The distance between neighbouring atoms is 140 nm.

Deduce whether superradiance can occur.

(3)

.....

.....

.....

.....

.....

**(Total for question = 3 marks)**

**Q14.**

Read the passage and answer the question that follows.

Atoms can be promoted into an excited state when they absorb energy. This results in the release of radiation at a random time. When several atoms are close together a quantum effect can occur. When one atom emits radiation this affects all the other nearby excited atoms. The excess energy of many of the atoms is released simultaneously and an intense flash of light is produced. This effect is called superradiance and can be used to produce lasers that emit a narrower range of frequencies than conventional lasers.

When superradiance occurs the atoms all absorb the same amount of energy.

Explain how this results in all the atoms emitting radiation of a particular frequency.

(5)

.....

.....

.....

.....

.....

.....

.....

.....

.....

.....

.....

.....

.....

.....

.....

.....

(Total for question = 5 marks)

**Q15.**

The image shows a diffraction pattern observed when a beam of electrons is fired at thin gold foil.



(Source: © The Reading Room/Alamy Stock Photo)

What property of electrons does this observation demonstrate?

- A** they exist in discrete energy levels
- B** they have a negative charge
- C** their small mass
- D** their wave nature

(Total for question = 1 mark)

**Q16.**

The Planck constant can be determined in a school laboratory using light emitting diodes (LEDs).

An LED emits light when the potential difference (p.d.) across it is large enough to transfer sufficient energy to an electron to result in the emission of a photon.

The electron must have energy greater than or equal to the photon energy.

The minimum p.d. required to produce light from LEDs emitting different frequencies was measured by increasing the p.d. from zero until light was first seen.

The graph shows the results.

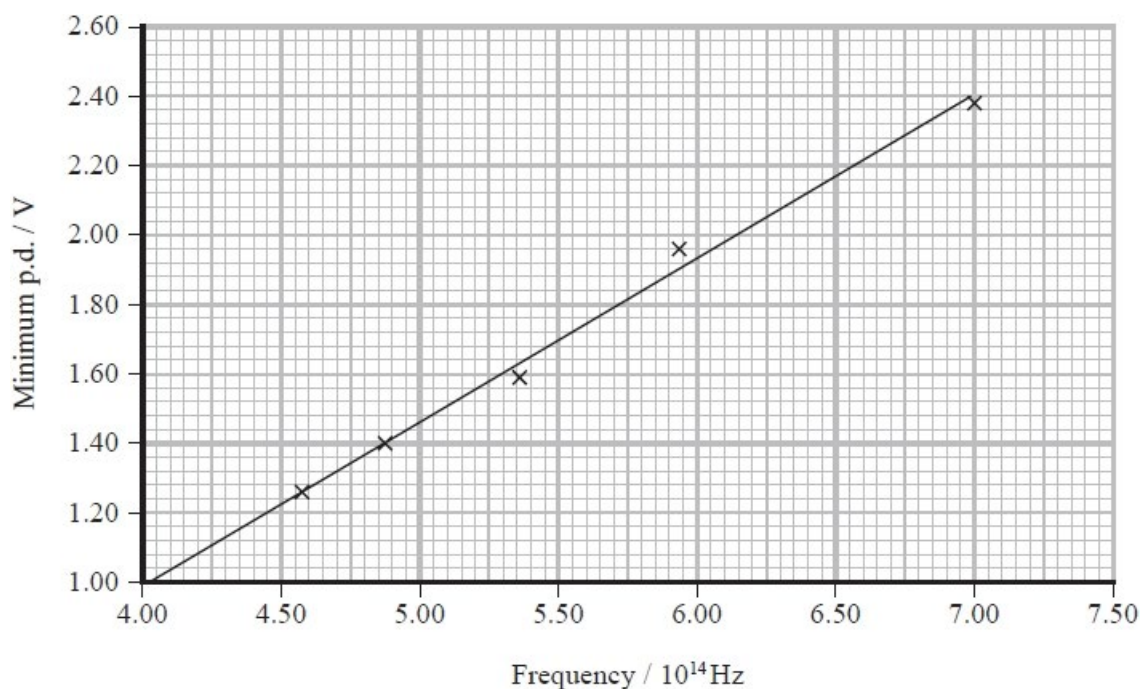

Determine the value of the Planck constant given by this graph.

(4)

.....

.....

.....

.....

.....

.....

.....

.....

Value of Planck constant given by graph = .....

**(Total for question = 4 marks)**

**Q17.**

(a) Solar sails are a form of propulsion for spacecraft. The sail is made of a thin sheet of reflective material. When photons of light from the Sun reflect from the material a force is exerted on the sail. The photons reflect with a momentum equal to their initial momentum but in the opposite direction.

(i) Show that a single photon of frequency  $1.5 \times 10^{15}$  Hz has a momentum of about  $3 \times 10^{-27}$  N s.

(2)

.....

.....

.....

.....

(ii) Hence determine the momentum transferred to the solar sail by this photon.

(1)

.....

Momentum transferred = .....

(b) An alternative method of producing a momentum change is being investigated. Researchers have suggested that 'larger changes in momentum could be produced by directing laser light at graphene oxide'. Electrons are emitted from the graphene oxide surface, resulting in a force being exerted on the graphene oxide in the opposite direction.

A researcher has suggested that one possible mechanism for the emission of the electrons is the photoelectric effect.

(i) Show that the maximum velocity for a photoelectron emitted after absorption of a photon of light of frequency  $1.5 \times 10^{15}$  Hz is about  $8 \times 10^5$  m s<sup>-1</sup>.  
work function of graphene oxide =  $6.7 \times 10^{-19}$  J

(3)

.....

.....

.....

.....

.....

.....

(ii) Hence calculate the momentum of the photoelectron.

(2)

.....

.....

.....

Momentum of photoelectron = .....

(c) Explain whether the suggestion in (b) that 'larger changes in momentum could be produced by directing laser light at graphene oxide' is true.

(2)

.....

.....

.....

.....

.....

.....

**(Total for question = 10 marks)**

**Q18.**

A solar panel uses electromagnetic radiation from the Sun to generate electricity. In one installation a sensor in the solar panel measures the intensity of radiation arriving from different directions. A motor rotates the solar panel so that it always faces the brightest part of the sky.

When light is incident on an LDR, electrons move to a higher energy level where they become conduction electrons. This causes the resistance of the LDR to decrease.

A student suggests that this is an example of the photoelectric effect. The student is not correct.

Compare and contrast the photoelectric effect with the effect of radiation incident on an LDR.

(6)

.....

.....

.....

.....

.....

.....

.....

.....

.....

.....

.....

**(Total for question = 6 marks)**

**Q19.**

In 1905 Einstein published his equation for the photoelectric effect.

In 1916 Millikan demonstrated that the maximum kinetic energy of photoelectrons is consistent with Einstein's equation.

Discuss the extent to which our current understanding of observations of the photoelectric effect supports the idea that light behaves as photons rather than as waves.

(6)

.....

.....

.....

.....

.....

.....

.....

.....

.....

.....

.....

.....

.....

.....

.....

.....

.....

.....

.....

.....

.....

.....

.....

(Total for question = 6 marks)

**Q20.**

The diagram shows apparatus that can be used to investigate the photoelectric effect.

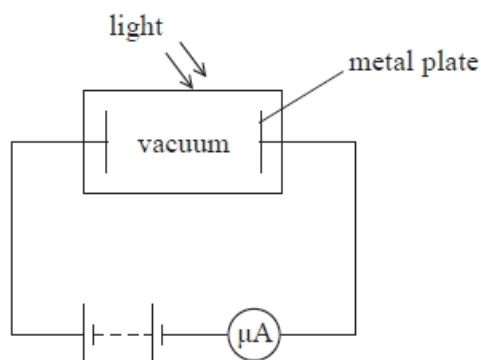



Light is shone onto the metal plate.

For a particular metal there will only be a current for frequencies of light greater than  $8.17 \times 10^{14}$  Hz.

If the applied potential difference is reversed and increased, the current will decrease and at a certain value of potential difference the current will be zero.

Calculate this potential difference when the frequency of the incident light is  $9.62 \times 10^{14}$  Hz.

(4)

.....

.....

.....

.....

.....

.....

.....

.....

Potential difference = .....

**Q21.**

The photoelectric effect provides evidence for the particle nature of electromagnetic radiation.

Which of the following observations of the photoelectric effect could also be explained using the wave nature of electromagnetic radiation?

- A** The emission of photoelectrons is instantaneous.
- B** The maximum kinetic energy of photoelectrons depends on frequency.
- C** The rate of emission of photoelectrons depends on intensity.
- D** There is a minimum frequency for emission of photoelectrons to occur.

**(Total for question = 1 mark)**

**Q22.**

A student has been learning about the photoelectric effect.

The student was asked by his teacher to explain the photoelectric effect. He gave the following explanation:

	Light above a certain threshold is able to free
	electrons from a metal, because the light gives
	energy to electrons in the metal.
	Some of this energy is used to release the
	electrons from the metal and the rest becomes
	kinetic energy of the freed electron.

Discuss whether the student's answer fully explains the photoelectric effect.

(4)

.....

.....

.....

.....

.....

.....

.....

.....

.....

.....

.....

.....

.....

.....

.....

.....

.....

.....

.....

.....

**(Total for question = 4 marks)**

**Q23.**

When light is incident on the surface of a metal, electrons may be emitted by the photoelectric effect. Observations of the photoelectric effect helped to establish that light can exhibit particle behaviour.

Which of the following observations of the photoelectric effect could also be explained by light behaving as a wave?

- A** Emission of photoelectrons occurs immediately the surface is illuminated.
- B** Photoelectrons are only emitted when the frequency of the light is more than a certain minimum value.
- C** The maximum kinetic energy of the photoelectrons is independent of the intensity of the incident light.
- D** When the intensity of the incident light increases, photoelectrons are emitted at a greater rate.

**(Total for question = 1 mark)**

**Q24.**

A student has been learning about the photoelectric effect.

This experiment demonstrates the particle nature of light.

Explain what is meant by the particle nature of light.

**(2)**

.....

.....

.....

.....

.....

**(Total for question = 2 marks)**

**Q25.**

Read the extract and answer the question that follows.

In the 17th century there were two proposed theories to explain the refraction of light. Using a wave model, Huygens stated that light slows down when it passes from air to water. Using a particle model, Newton stated that light speeds up when it passes from air to water. Newton's theory was more readily accepted until the speed of light in water was measured in the 19th century.

In the early 20th century, Einstein used observations from the photoelectric effect to provide evidence for the particle model of light.

Nowadays, both the wave model of light and the particle model of light are accepted, as each can be used to explain different aspects of the behaviour of light.

In a demonstration of the photoelectric effect, electromagnetic radiation is shone onto a clean metal surface. It can be shown that the metal loses negative charge when the radiation has a frequency above a certain threshold frequency.

Explain how the particle model of light is consistent with this observation.

(3)

.....

.....

.....

.....

.....

.....

**(Total for question = 3 marks)**

**Q26.**

Which of the following provides evidence for the particle model of electromagnetic radiation?

- A** diffraction
- B** interference
- C** polarisation
- D** visible line spectra

**(Total for question = 1 mark)**

**Q27.**

In 2016 the Breakthrough Starshot initiative was announced. This project intends to send a fleet of small probes to Proxima Centauri, the nearest star to the Sun. This journey would take about twenty years.

The composition of a star can be determined by analysis of its absorption spectrum.

Explain why there are certain specific frequencies missing from the spectrum.

(5)

.....

.....

.....

.....

.....

.....

.....

.....

.....

.....

**(Total for question = 5 marks)**

**Q28.**

When monochromatic light is incident on the surface of a metal, electrons are emitted by the photoelectric effect.

If other conditions are unchanged, the maximum kinetic energy of the electrons will be increased by

- A** increasing the frequency of the incident light.
- B** increasing the intensity of the incident light.
- C** using a metal with a higher threshold frequency.
- D** using a metal with a higher work function.

**(Total for question = 1 mark)**

**Q29.**

Some of the energy levels of an atom of a gas are shown.

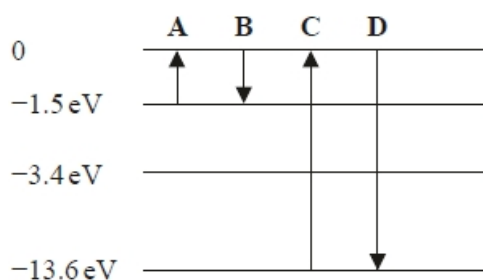

During which transition, A, B, C or D, is electromagnetic radiation with the shortest wavelength emitted?

- A
- B
- C
- D

(Total for question = 1 mark)

**Q30.**

An electron beam is directed onto crystalline graphite. A fluorescent screen on the other side of the crystal shows the pattern in Figure 1. The brighter areas correspond to higher electron intensity.

The speed of the electrons is increased and the resulting pattern is shown in Figure 2.

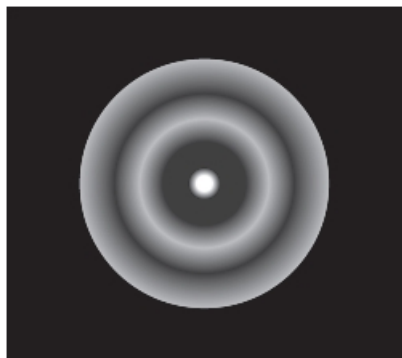

Figure 1



Figure 2



The spectrometer allows parallel rays of light to be passed through a diffraction grating and the resulting angles of diffraction to be measured.

The spectrometer and diffraction grating are used to analyse the light from a sodium lamp. In the sodium lamp, sodium is heated until it becomes a vapour and an electric current is passed through it. The vapour then emits light.

After the light passes through the diffraction grating a line spectrum is observed.

(i) Explain why only certain wavelengths are observed.

(6)

.....

.....

.....

.....

.....

.....

.....

.....

.....

.....

.....

.....

.....

.....

.....

.....

.....

.....

.....

.....

.....

.....

(ii) Diffraction gratings with the following spacings are available:

$d/10^{-6}$ m	1.0	1.7	2.0	3.3
---------------	-----	-----	-----	-----

Explain which would be the best spacing to use to measure the diffraction angle for the third order maximum for yellow light of wavelength 589 nm.

(3)

.....

.....

.....

.....

.....

.....

(Total for question = 9 marks)



**Q32.**

Barnard's star is a red dwarf star in the vicinity of the Sun. The wavelength of a line in the spectrum of light emitted from Barnard's star is measured to be 656.0 nm. The same light produced by a source in a laboratory has a wavelength of 656.2 nm.

Visible light from the star originates from the photosphere. In the photosphere of Barnard's star, hydrogen and helium atoms are at a temperature of 3100 K.

- (i) Calculate the mean kinetic energy of an atom in the photosphere at a temperature of 3100 K.

(2)

.....  
.....  
.....  
.....

Mean kinetic energy = .....

- (ii) Describe how these atoms emit visible light.

(2)

.....  
.....  
.....  
.....  
.....  
.....

**(Total for question = 4 marks)**

**Q33.**

A fine-beam tube is used for investigating properties of electrons.

An electron beam is produced inside a spherical glass bulb. The bulb contains neon gas at a very low pressure.

\* Interactions between electrons and the neon atoms in the tube make the beam visible. Part of the spectrum of visible light produced by these interactions is shown.



(Source: © MoFarouk/Shutterstock)

Explain the process that results in the emission of this spectrum. Your answer should include reference to energy levels in atoms.

(6)

.....

.....

.....

.....

.....

.....

.....

.....

.....

.....

.....

.....

.....

.....

.....

.....

.....

.....

.....

.....

.....

.....

**(Total for question = 6 marks)**

**Q34.**

Our understanding of the atom has developed over time, from early models in which atoms were considered to be hard incompressible spheres, through to the nuclear model of the atom and the ladder model in which electrons exist in a discrete number of allowed energy states.

In the energy ladder model of the atom, electrons exist in a discrete number of allowed energy states. The collision of electrons with gold atoms may lead to the production of high frequency electromagnetic radiation.

Explain how high frequency electromagnetic radiation may be produced when electrons collide with atoms in a metal.

(4)

.....

.....

.....

.....

.....

.....

.....

.....

.....

.....

**(Total for question = 4 marks)**

**Q35.**

Filament and fluorescent are two types of light bulb.

Filament light bulbs contain a tightly coiled wire filament, surrounded by an inert gas and encased in a thin glass bulb. When the potential difference (p.d.) across the bulb is sufficient, the filament heats up, emitting visible light.

Fluorescent light bulbs use a long tube of glass containing a small amount of mercury. When a sufficient p.d. is applied across the ends of the tube, electrons moving through the tube cause the mercury to become a vapour and emit photons in the ultraviolet part of the electromagnetic spectrum. The collisions of these photons with the phosphor coating of the tube result in the emission of photons of visible light.

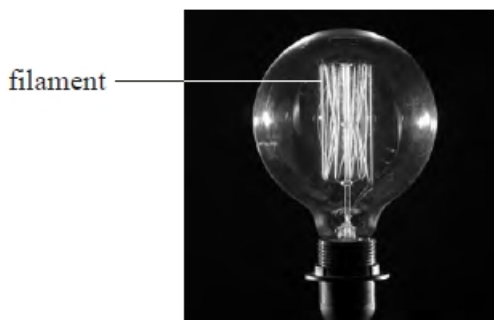

Filament bulb



Fluorescent bulb

(i) Explain how the wire in the filament lamp gets hot when a p.d. is applied.

(2)

.....

.....

.....

.....

.....

(ii) Explain how the fluorescent bulb emits photons when sufficient p.d is applied.

(2)

.....

.....

.....

.....

.....

**(Total for question = 4 marks)**

**Q36.**

An electron travels at a velocity  $v$ .

Which of the following is the correct expression for the de Broglie wavelength  $\lambda$  of the electron?

**A**  $\lambda = \frac{3.00 \times 10^8}{9.11 \times 10^{-31} \times v}$

**B**  $\lambda = \frac{9.11 \times 10^{-31} \times v}{3.00 \times 10^8}$

**C**  $\lambda = \frac{6.63 \times 10^{-34}}{9.11 \times 10^{-31} \times v}$

**D**  $\lambda = \frac{9.11 \times 10^{-31} \times v}{6.63 \times 10^{-34}}$

**(Total for question = 1 mark)**

**Q37.**

The diagram shows the lowest energy levels for a certain atom.

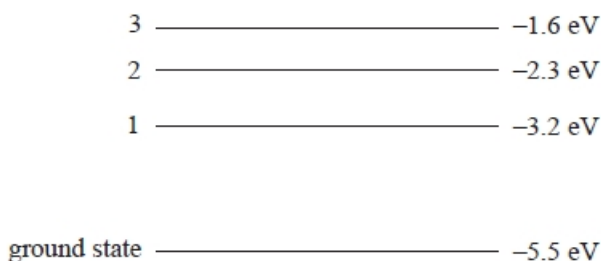

A photon with energy 3.2 eV is absorbed.

An electron could move from

(1)

- A** ground state to level 1.
- B** ground state to level 2.
- C** level 1 to ground state.
- D** level 2 to ground state.

**(Total for question = 1 mark)**

**Q38.**

In a spectrometer, light from a tube of hot gas is passed through a diffraction grating.

The diagram shows the zero order and the first order maxima for the line spectrum produced.

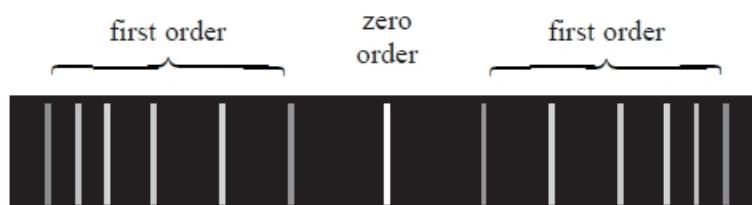

Explain why lines of different wavelengths are produced by the gas.

(4)

.....

.....

.....

.....

.....

.....

.....

.....

**Q39.**

When a large potential difference is applied to a discharge tube, the gas in the discharge tube emits coloured light. When this light is passed through a diffraction grating, an emission spectrum which is made up of a series of lines of different wavelengths may be seen.

The photographs show the spectra produced from a tube containing hydrogen and a tube containing helium.

Hydrogen:





**Q40.**

The energy level diagram shows four possible energy transitions for an electron in an atom.

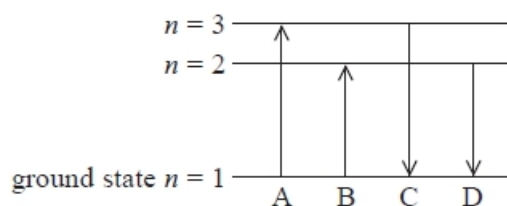

Which arrow shows the transition made by the electron when the atom emits radiation with the longest wavelength?

- A
- B
- C
- D

(Total for question = 1 mark)

**Q41.**

The diagram represents some of the energy levels for an atom.

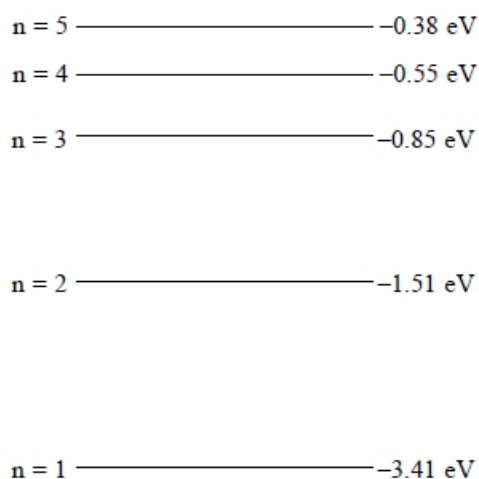



Calculate the lowest frequency of light that would be absorbed by an electron with energy  $-0.85$  eV in the atom shown.

(3)

.....

.....

.....

.....

.....

.....

.....

Frequency = .....

(Total for question = 3 marks)

**Q42.**

The photograph shows a school spectrometer.

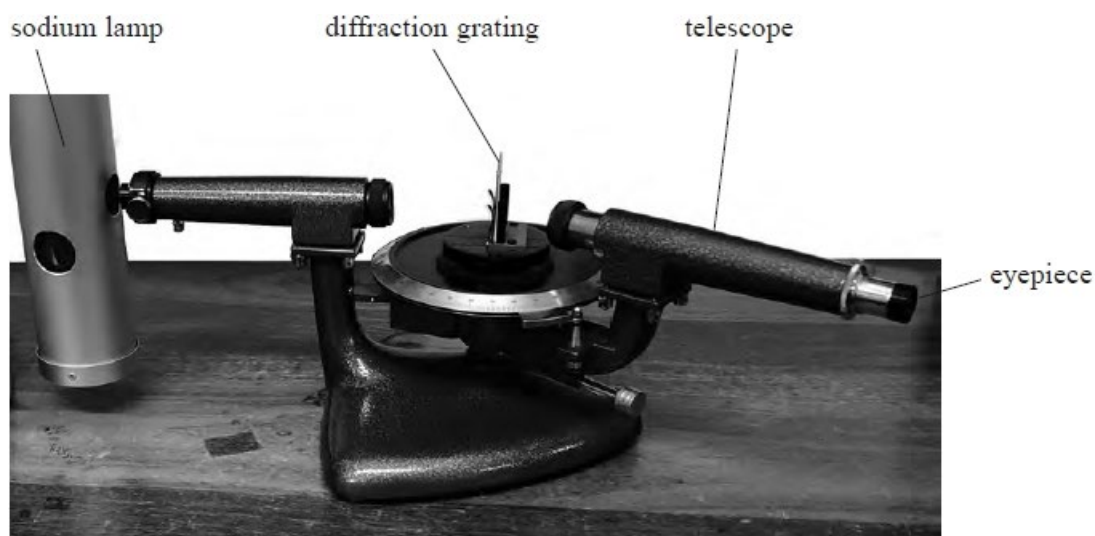

The spectrometer allows parallel rays of light to be passed through a diffraction grating and the resulting angles of diffraction to be measured.

The diagram shows some of the energy levels in a sodium atom.

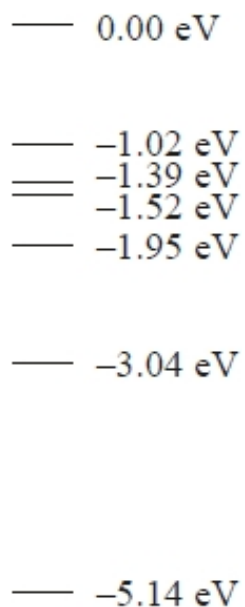

Add an arrow to the diagram to show the transition involved in the emission of yellow light of wavelength 589 nm.

Show your working below.

(4)

.....

.....

.....

.....

.....

.....

.....

.....

.....

.....

.....

(Total for question = 4 marks)

**Q43.**

An electron in its ground state absorbs electromagnetic radiation of wavelength  $\lambda$ . The energy level diagram represents the resulting energy transition of the electron.

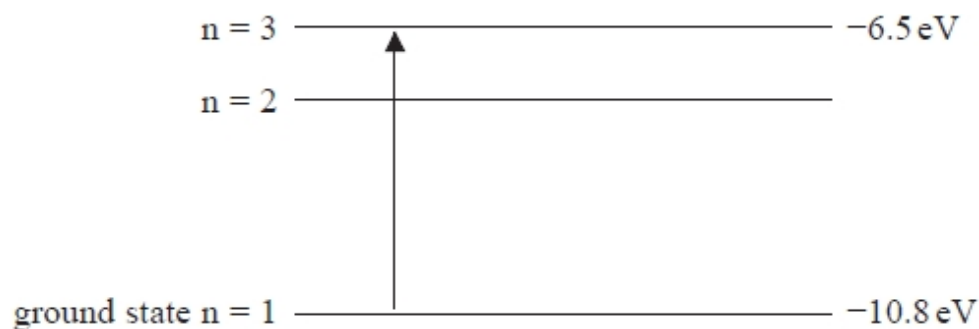

The electron eventually returns to its ground state.

Explain, with reference to the energy level diagram, how this may result in the emission of radiation with a longer wavelength than  $\lambda$ .

(3)

.....

.....

.....

.....

.....

.....

**(Total for question = 3 marks)**

**Q44.**

The diagram shows five energy levels in an atom.

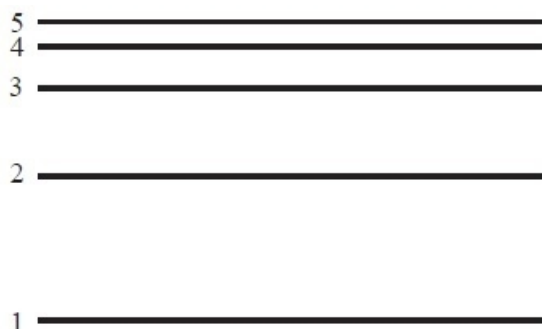

Electromagnetic radiation is incident on the atom.

Which transition would be caused by the absorption of the lowest frequency of radiation?

- A** 1 to 5
- B** 1 to 2
- C** 4 to 5
- D** 5 to 4

**(Total for Question = 1 mark)**

**Q45.**

Einstein's photoelectric equation states

$$hf = \phi + \frac{1}{2}mv_{\max}^2$$

The quantity denoted by  $\phi$  is the minimum

- A** amount of energy of a photon needed to release an electron.
- B** amount of energy of an electron needed to release a photon.
- C** frequency of a photon needed to release an electron.
- D** frequency of an electron needed to release a photon.

**(Total for question = 1 mark)**

**Q46.**

In 1965, Richard Feynman proposed a double slit experiment to investigate the wave properties of electrons.

The experiment was later carried out using the arrangement shown.

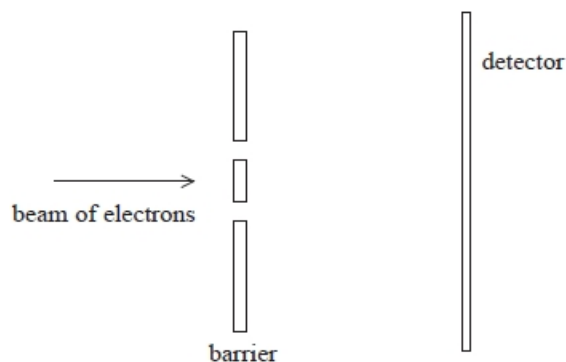

A beam of electrons was directed at a barrier with two slits.

The detector recorded the positions where electrons arrived after passing through the slits.

The following pattern was obtained. Black dots represent points where electrons were detected. A band where electrons were not detected has been labelled X and a band where electrons were detected has been labelled Y.

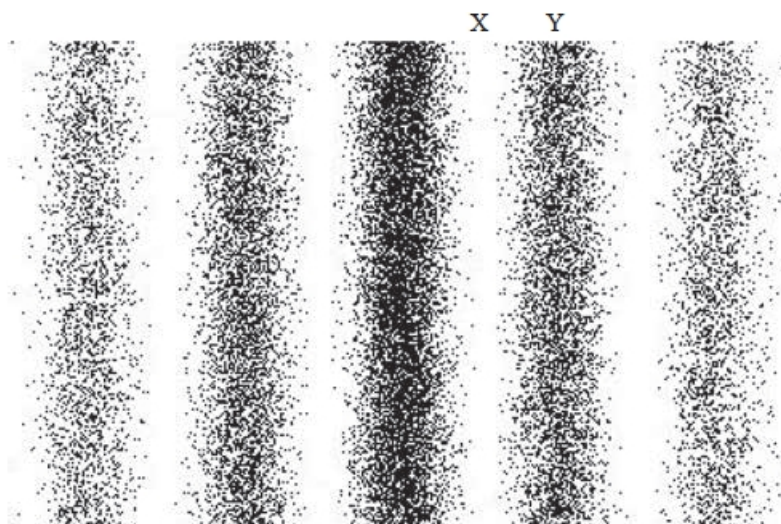

The path difference for electrons arriving at band X from the separate slits was  $2.5 \times 10^{-1}$  m. For electrons arriving at band Y the path difference was  $5.0 \times 10^{-1}$  m.

Explain why this pattern is observed when the electron energy is  $9.6 \times 10^{-1}$  J.

The electrons are travelling at non-relativistic speeds.

(6)

.....

.....

.....

.....

.....

.....

.....

.....

.....

.....

.....

.....

.....

.....

.....

.....

.....

.....

.....

.....

.....

.....

**(Total for question = 6 marks)**



**Q48.**

The photoelectric effect was discovered by Hertz who investigated the effect of ultraviolet radiation incident upon the surface of zinc. The effect was found to depend on the frequency of the radiation.

(a) State what is meant by threshold frequency.

(1)

.....  
.....  
.....

(b) Light of frequency  $8.9 \times 10^{14}$  Hz is incident upon the surface of a different metal. The photoelectrons have a maximum speed of  $6.7 \times 10^5$  m s<sup>-1</sup>.

Calculate the work function of the metal in eV.

(4)

.....  
.....  
.....  
.....  
.....  
.....  
.....  
.....  
.....  
.....  
.....

Work function = ..... eV

**(Total for question = 5 marks)**



**Q49.**

In the 19th century experiments with magnetic and electric field deflections were used to determine the charge to mass ratio of electrons.

Later experiments showed the diffraction of electrons as they passed through thin metal foils.

Deduce what these experiments tell us about electrons.

(3)

.....

.....

.....

.....

.....

.....

.....

.....

.....

.....

.....

.....

**(Total for question = 3 marks)**

**Q50.**

Read the extract and answer the question that follows.

In the 17th century there were two proposed theories to explain the refraction of light. Using a wave model, Huygens stated that light slows down when it passes from air to water. Using a particle model, Newton stated that light speeds up when it passes from air to water. Newton's theory was more readily accepted until the speed of light in water was measured in the 19th century.

In the early 20th century, Einstein used observations from the photoelectric effect to provide evidence for the particle model of light.

Nowadays, both the wave model of light and the particle model of light are accepted, as each can be used to explain different aspects of the behaviour of light.

In the 1920s, experiments demonstrating diffraction of electrons confirmed de Broglie's work on the wave nature of particles.

In one such experiment an electron had a momentum of  $4.8 \times 10^{-24} \text{ kg m s}^{-1}$ . Measurements confirmed that the de Broglie wavelength of the electron was  $1.40 \times 10^{-10} \text{ m}$ .

Deduce that these observations are consistent with the value of  $h$  given on the data sheet provided.

(3)

.....

.....

.....

.....

.....

.....

**(Total for question = 3 marks)**

**Q51.**

In 1905 Einstein published his equation for the photoelectric effect.

In 1916 Millikan demonstrated that the maximum kinetic energy of photoelectrons is consistent with Einstein's equation.

Millikan used his data to obtain a value of the Planck constant.

The following graph of maximum kinetic energy of photoelectrons against frequency was produced from his data for the photoelectric effect using lithium.

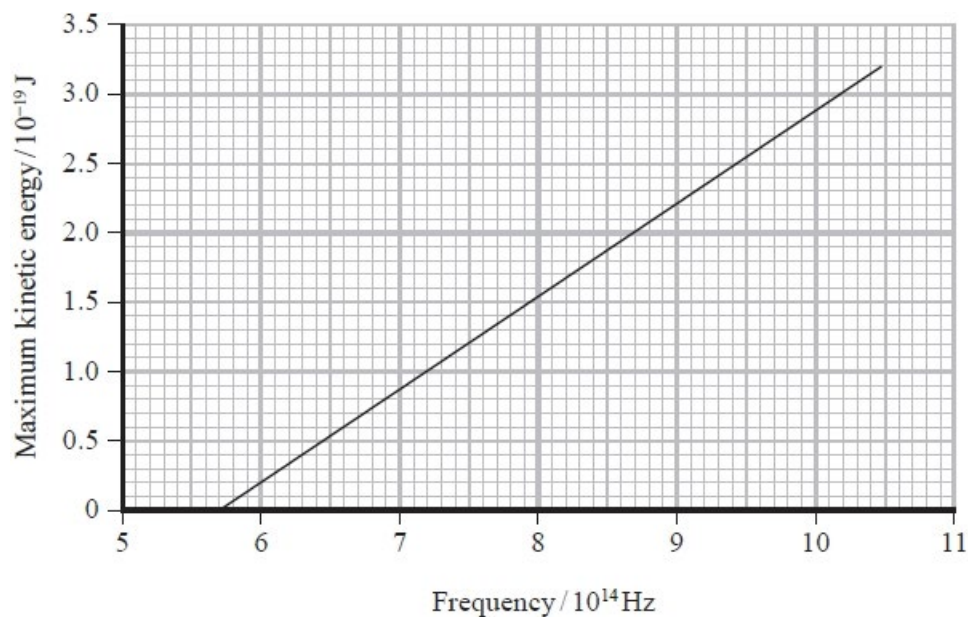

Millikan suggested that the uncertainty from his results for lithium was as little as 1%.

Determine whether the value of the Planck constant obtained from this graph is within 1% of the value stated on the data sheet for this examination paper.

(3)

.....

.....

.....

.....

.....

.....

.....

.....

.....

**(Total for question = 3 marks)**

**Q52.**

In the 1920s Louis de Broglie proposed that an electron could behave as a wave.

Calculate the wavelength of an electron that is travelling at a speed of  $2.2 \times 10^7 \text{ms}^{-1}$ .

(3)

.....

.....

.....

.....

.....

.....

Wavelength = .....

**(Total for question = 3 marks)**

**Q53.**

In 1925 Franck and Hertz were awarded the Nobel Prize in Physics "for their discovery of the laws governing the impact of an electron upon an atom".

In one of their experiments, a beam of high-speed electrons is fired through mercury vapour.

An electron in the beam collides with a mercury atom, which becomes excited. The atom returns to its initial state by emitting electromagnetic radiation of a single frequency.

Explain why excited atoms only emit certain frequencies of radiation.

(5)

.....

.....

.....

.....

.....

.....

.....

.....

.....

.....

.....

**(Total for question = 5 marks)**

**Q54.**

The Planck constant is an important universal constant used in the study of wave–particle duality.

Atomic electrons are confined within the atom. One model of atomic electrons suggests that the wave associated with an atomic electron forms a standing wave that fits exactly into the diameter  $d$  of the atom.

(i) The diagram shows the lowest frequency standing wave that fits into the diameter of the atom.

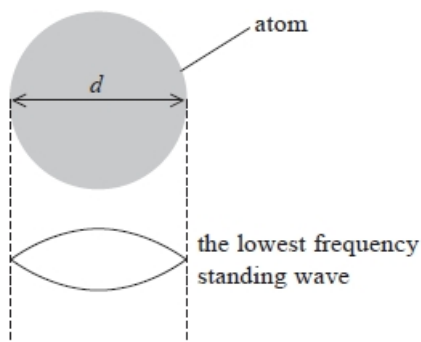

Calculate the momentum of the electron.

$d = 2.00 \times 10^{-10}\text{m}$

(3)

.....

.....

.....

.....

.....

Momentum = .....

(ii) Electrons in an atom can only exist at discrete energy levels.

Explain how this standing wave model can account for this.

(2)

.....

.....

.....

.....

.....

**(Total for question = 5 marks)**

**Q55.**

In an experiment to determine the wavelength of light, a diffraction grating is illuminated with light from a monochromatic source. A series of bright spots is observed.

The experiment is repeated and the distance between consecutive bright spots increases.

Select the row of the table that gives two changes to the experimental set up which would both cause the distance between consecutive bright spots to increase.

(1)

	Number of slits per mm in the diffraction grating	Wavelength of the light source
<input type="checkbox"/> A	Increased	Increased
<input type="checkbox"/> B	Increased	Decreased
<input type="checkbox"/> C	Decreased	Increased
<input type="checkbox"/> D	Decreased	Decreased

(Total for question = 1 mark)

**Q56.**

In an investigation of the photoelectric effect, electromagnetic radiation of frequency  $f$  was directed onto a metal plate. The maximum kinetic energy  $E$  of the photoelectrons emitted from the metal plate was determined. The procedure was repeated for a range of frequencies.

The graph shows how  $E$  depended upon  $f$ .

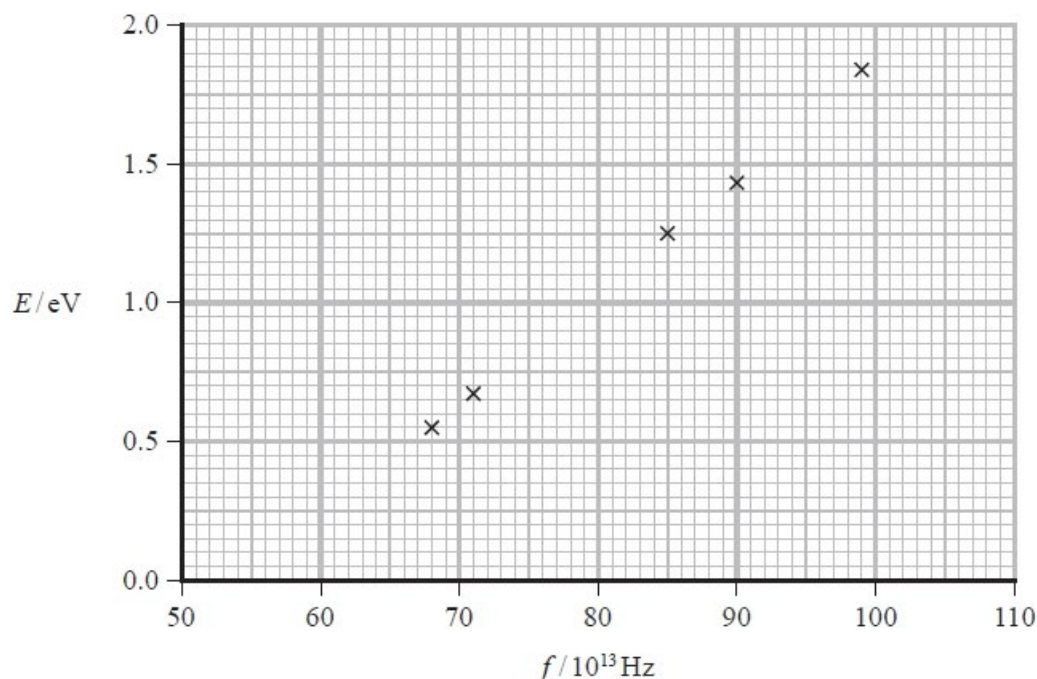

Determine a value for the Planck constant,  $h$ , in J s.

(4)

.....

.....

.....

.....

.....

.....

.....

.....

$h =$  ..... J s

(Total for question = 4 marks)

**Q57.**

In an investigation of the photoelectric effect, electromagnetic radiation of frequency  $f$  was directed onto a metal plate. The maximum kinetic energy  $E$  of the photoelectrons emitted from the metal plate was determined. The procedure was repeated for a range of frequencies.

The graph shows how  $E$  depended upon  $f$ .

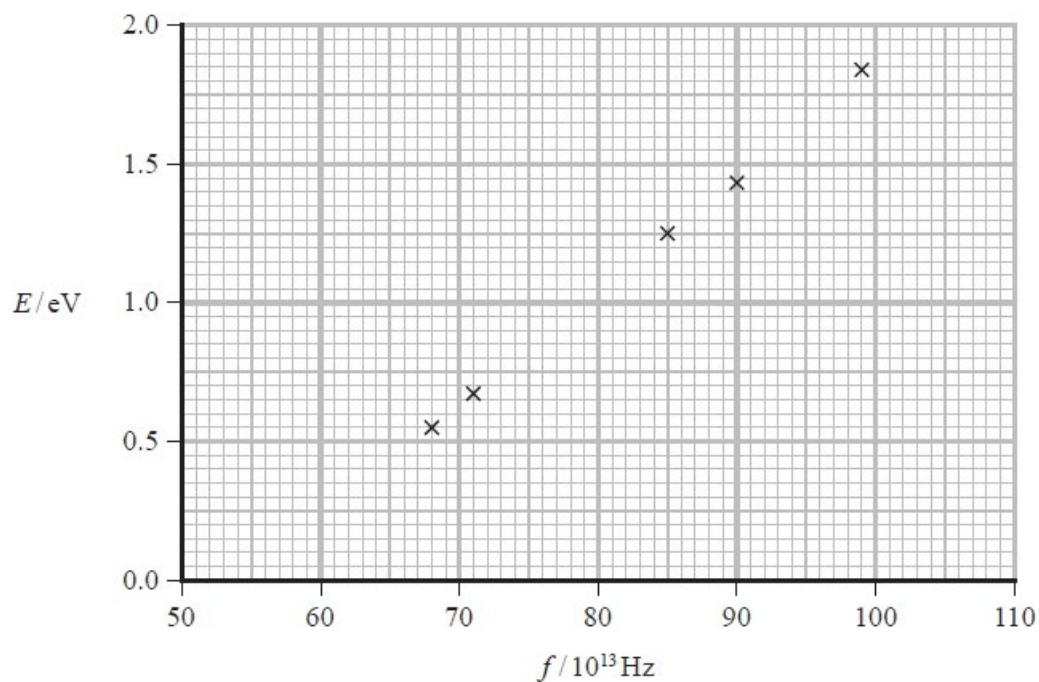

The table gives data for different metal surfaces.

Metal surface	Work function / eV
Caesium	2.0
Calcium	2.9
Magnesium	3.7

Deduce which metal was being used in the investigation.

(3)

.....

.....

.....

.....

.....

.....

.....

**(Total for question = 3 marks)**



## Mark Scheme – Particle Nature and The Wave-particle Duality

Q1.

Question Number	Acceptable answers	Additional guidance	Mark
	<ul style="list-style-type: none"> <li>Use of <math>E=hf</math> (1)</li> <li>Use of <math>c = f\lambda</math> (1)</li> <li>Apply conversion factor of <math>1.6 \times 10^{-19}</math> for photon energy from J to eV (1)</li> <li>Level = -5.74 (eV) (1)</li> </ul>	<p><u>Example of calculation</u></p> $f = 3.00 \times 10^8 \text{ m s}^{-1} / 6.1 \times 10^{-7} \text{ m}$ $= 4.91 \times 10^{14} \text{ Hz}$ $E = 6.63 \times 10^{-34} \text{ J s} \times 4.91 \times 10^{14} \text{ Hz}$ $= 3.26 \times 10^{-19} \text{ J}$ $3.26 \times 10^{-19} \text{ J} / 1.6 \times 10^{-19} \text{ C} = 2.04 \text{ eV}$ $\text{Level} = -3.71 \text{ eV} - 2.04 \text{ eV} = -5.75 \text{ eV}$	4

Q2.

Question number	Acceptable answers	Additional guidance	Mark
	<ul style="list-style-type: none"> <li>Calculates wavelength <math>\lambda</math> (circumference) (1)</li> <li>Use of <math>p = h/\lambda</math> (1)</li> <li><math>v = 2.2 \times 10^6 \text{ m s}^{-1}</math> (1)</li> </ul>	<p>Example of calculation:</p> $\lambda = 2\pi r = 2\pi \times 5.3 \times 10^{-11} \text{ m} = 3.33 \times 10^{-10} \text{ m}$ $\lambda = h/mv \text{ so } v = h/m\lambda$ $v = 6.63 \times 10^{-34} \text{ J s} / (9.1 \times 10^{-31} \text{ kg} \times 3.33 \times 10^{-10} \text{ m})$ $v = 2.188 \times 10^6 \text{ m s}^{-1}$	3

Q3.

Question Number	Answer	Mark
	<b>C</b> $\text{kg m}^2 \text{s}^{-1}$	1
	Incorrect Answers: <b>A</b> – N is not an SI base unit and incorrect arrangement <b>B</b> – N is not an SI base unit <b>D</b> – incorrect arrangement	

Q4.

Question Number	Answer	Mark
	B	1

Q5.

Question Number	Acceptable Answer	Additional Guidance	Mark
	<ul style="list-style-type: none"> <li>Stars emitting infra-red radiation can be detected above the atmosphere (1)</li> <li>Or Some visible wavelengths emitted by stars reduced to 50% intensity or less by the atmosphere</li> </ul>	Accept identified wavelength range	1

Q6.

Question Number	Acceptable Answers	Additional guidance	Mark
	<ul style="list-style-type: none"> <li>Use of <math>hf = \phi + \frac{1}{2}mv^2</math> (1)</li> <li><math>v = 6.3 \times 10^6 \text{ m s}^{-1}</math> (1)</li> </ul>	<p><u>Example of Calculation</u></p> $E_k = (6.63 \times 10^{-34} \text{ J s} \times 2.8 \times 10^{16} \text{ s}^{-1}) - 6.9 \times 10^{-19} \text{ (J)} = 1.78712 \times 10^{-17} \text{ J}$ $v = \sqrt{\frac{2 \times 1.78712 \times 10^{-17} \text{ J}}{9.11 \times 10^{-31} \text{ kg}}} = 6.26 \times 10^6 \text{ m s}^{-1}$	2

Q7.

Question Number	Acceptable answers	Additional guidance	Mark
	<ul style="list-style-type: none"> <li>Use of <math>c=f\lambda</math> and <math>E=hf</math> (1)</li> <li>Converts <math>eV</math> to J (1)</li> <li>Use of <math>E = W + KE_{max}</math> (1)</li> <li><math>KE_{max} = 1.3 \times 10^{-19} \text{ J}</math> (1)</li> </ul>	<p>Example of calculation:</p> $E = \frac{hc}{\lambda} = \frac{6.63 \times 10^{-34} \text{ J s} \times 3 \times 10^8 \text{ m s}^{-1}}{2.54 \times 10^{-7} \text{ m}} = 7.831 \times 10^{-19} \text{ J}$ <p>Work function = <math>6.51 \times 10^{-19} \text{ J}</math></p> $E = W + KE_{max}$ $KE_{max} = 7.83 \times 10^{-19} \text{ J} - 6.51 \times 10^{-19} \text{ J} = 1.32 \times 10^{-19} \text{ J}$	4

Q8.

Question Number	Acceptable Answers	Additional guidance	Mark
	<ul style="list-style-type: none"> <li>Use of <math>p = mv</math> with <math>m = 9.11 \times 10^{-31}</math> and <math>v = 0.02 \times 3.0 \times 10^8</math> (1)</li> <li>Use of <math>\lambda = \frac{h}{p}</math> (1)</li> <li><math>\lambda = 1.2 \times 10^{-10} \text{ m}</math> (1)</li> </ul>	<p><u>Example of calculation</u></p> $\lambda = \frac{6.63 \times 10^{-34} \text{ J s}}{9.11 \times 10^{-31} \text{ kg} \times 0.02 \times 3.0 \times 10^8 \text{ m s}^{-1}}$ $\lambda = 1.2 \times 10^{-10} \text{ m}$	3

Q9.

Question Number	Acceptable Answers	Additional Guidance	Mark																												
*	<p>This question assesses a student's ability to show a coherent and logical structured answer with linkage and fully-sustained reasoning. Marks are awarded for indicative content and for how the answer is structured and shows lines of reasoning. The following table shows how the marks should be awarded for indicative content.</p> <table border="1"> <thead> <tr> <th>Number of indicative points seen in answer</th> <th>Number of marks awarded for indicative points</th> </tr> </thead> <tbody> <tr> <td>6</td> <td>4</td> </tr> <tr> <td>5-4</td> <td>3</td> </tr> <tr> <td>3-2</td> <td>2</td> </tr> <tr> <td>1</td> <td>1</td> </tr> <tr> <td>0</td> <td>0</td> </tr> </tbody> </table> <p><b>Particle model</b></p> <ul style="list-style-type: none"> <li>One photon interacts with one electron</li> <li>And each photon has energy proportional to the frequency, Or reference to <math>E=hf</math></li> <li>The electron is emitted (instantly) only if the energy of the photon is greater than the work function (of the metal) Or The electron is emitted (instantly) only if the energy of the photon is greater than the energy needed for an electron to break free (from metal surface)</li> <li>Any photon energy over and above the work function is gained by the electron as kinetic energy</li> </ul> <p><b>Wave model</b></p> <ul style="list-style-type: none"> <li>It would be expected that the energy of the electron would build up and eventually be emitted.</li> <li>The (kinetic) energy of the (emitted) electrons would depend on the intensity of the wave (and not the frequency)</li> </ul>	Number of indicative points seen in answer	Number of marks awarded for indicative points	6	4	5-4	3	3-2	2	1	1	0	0	<p>The following table shows how the marks should be awarded for structure and lines of reasoning</p> <table border="1"> <thead> <tr> <th></th> <th>Number of marks awarded for structure and lines of reasoning</th> </tr> </thead> <tbody> <tr> <td>Answer shows a coherent and logical structure with linkage and fully sustained lines of reasoning demonstrated throughout</td> <td>2</td> </tr> <tr> <td>Answer is partially structured with some linkages and lines of reasoning</td> <td>1</td> </tr> <tr> <td>Answer has no linkage between points and is unstructured</td> <td>0</td> </tr> </tbody> </table> <p><b>Linkage marks</b></p> <table border="1"> <thead> <tr> <th>Indicative content points</th> <th>Possible linkage marks</th> </tr> </thead> <tbody> <tr> <td>0, 1</td> <td>0</td> </tr> <tr> <td>2, 3</td> <td>1</td> </tr> <tr> <td>4, 5, 6 with points from both models</td> <td>2</td> </tr> </tbody> </table>		Number of marks awarded for structure and lines of reasoning	Answer shows a coherent and logical structure with linkage and fully sustained lines of reasoning demonstrated throughout	2	Answer is partially structured with some linkages and lines of reasoning	1	Answer has no linkage between points and is unstructured	0	Indicative content points	Possible linkage marks	0, 1	0	2, 3	1	4, 5, 6 with points from both models	2	6
Number of indicative points seen in answer	Number of marks awarded for indicative points																														
6	4																														
5-4	3																														
3-2	2																														
1	1																														
0	0																														
	Number of marks awarded for structure and lines of reasoning																														
Answer shows a coherent and logical structure with linkage and fully sustained lines of reasoning demonstrated throughout	2																														
Answer is partially structured with some linkages and lines of reasoning	1																														
Answer has no linkage between points and is unstructured	0																														
Indicative content points	Possible linkage marks																														
0, 1	0																														
2, 3	1																														
4, 5, 6 with points from both models	2																														

## Q10.

Question Number	Acceptable Answers	Additional Guidance	Mark
	<p>An explanation that makes reference to:</p> <ul style="list-style-type: none"> <li>if photon energy equal to an energy level difference in the elements present (1)</li> <li>then the photon can be absorbed by an electron and the electron is excited/moves to higher level (1)</li> <li>so the absorption spectrum is created because the frequencies of the absorbed photons are missing from the continuous spectrum produced by the star (1)</li> </ul>	Accept references to re-emission in all directions.	3

## Q11.

Question Number	Acceptable answers	Additional guidance	Mark
(a)	<ul style="list-style-type: none"> <li>(UV radiation consists of) photons (1)</li> <li>One photon interacts with one electron (1)</li> <li>Or energy of photon depends on frequency (1)</li> <li>Electrons released if energy (of photon) greater than work function (1)</li> <li>Or frequency is greater than threshold frequency (1)</li> <li>Or <u>energy</u> supplied is sufficient to remove electron</li> </ul>	Accept quanta/packets of energy	3

Question Number	Acceptable answers	Additional guidance	Mark
(b)(i)	<ul style="list-style-type: none"> <li>when slider at the bottom - reading on voltmeter is zero (1)</li> <li>Or minimum resistance - reading on voltmeter is zero (1)</li> <li>When slider at the top – reading on voltmeter is 1.5 V (1)</li> <li>Or maximum resistance - reading on voltmeter is 1.5 V (1)</li> <li>Potential difference split between top and bottom part of resistor (either side of slider) (1)</li> <li>Or reading on voltmeter depends on the ratio of resistances (either side of slider)</li> <li>Or moving the slider changes the resistance that the voltmeter is across</li> </ul>		3

Question Number	Acceptable answers	Additional guidance	Mark
(b)(ii)	Maximum Kinetic Energy of electron = 0.6 (eV) (1)		1

Question Number	Acceptable answers	Additional guidance	Mark
(c)	<p><b>Max 4</b></p> <p>Valid because:</p> <ul style="list-style-type: none"> <li>• Moon and photocell both have vacuum (1)</li> <li>• Both demonstration and theory use photoelectric effect (1)</li> </ul> <p>Not valid because:</p> <ul style="list-style-type: none"> <li>• Different wavelengths in each case (1)</li> <li>• On the moon there is dust not metal (1)</li> <li>• Dust is free to move but the metal plate is fixed (1)</li> <li>• On the moon UV removes electrons from (individual) <u>atoms</u> and in the demo light removes electrons from metal <u>surface</u> (1)</li> <li>• Demonstration is based on photoelectric effect but effect on moon could be ionisation (1)</li> </ul>	<p>Full marks can only be scored if a correct link is made between at least one physics point and the demonstration being valid or not valid</p> <p>Accept the same concept for photoelectric effect</p> <p>Accept one uses light the other UV</p> <p>Accept different materials for MP4</p>	4

## Q12.

Question Number	Acceptable Answers	Additional Guidance	Mark
	C		1

## Q13.

Question Number	Acceptable Answers	Additional guidance	Mark
	<ul style="list-style-type: none"> <li>• Use of <math>E = hf</math> and <math>v = f\lambda</math> (1)</li> <li>• Converts between eV to J (1)</li> <li>• <math>\lambda = 2.0 \times 10^{-7}</math> (m) and conclusion that superradiance can occur (1)</li> </ul>	<p><u>Example of calculation</u>  <math>E = 6.2 \text{ eV} \times 1.6 \times 10^{-19} \text{ C}</math></p> $E = \frac{6.63 \times 10^{-34} \text{ Js} \times 3.0 \times 10^8 \text{ ms}^{-1}}{\lambda}$ <p><math>\lambda = 201 \text{ nm}</math> so superradiance can occur</p>	3

Q14.

Question Number	Acceptable Answers	Additional guidance	Mark
	<ul style="list-style-type: none"> <li>Atoms contain discrete energy levels (1)</li> <li>The atom/electron loses energy and falls back down energy levels emitting a <u>photon</u> (1)</li> <li>with energy equal to the difference in energy levels (1)</li> <li>Energy (of photon) is proportional to frequency (1)</li> <li>So emitted frequency of radiation corresponds to the difference in energy levels of a particular atom (1)</li> </ul>		5

Q15.

Question Number	Answer	Mark
	<b>D</b> their wave nature	<b>1</b>
	Incorrect Answers: <b>A</b> not demonstrated by this observation <b>B</b> not demonstrated by this observation <b>C</b> not demonstrated by this observation	

Q16.

Question Number	Acceptable answers	Additional guidance	Mark
	<ul style="list-style-type: none"> <li>Substitute <math>eV</math> for <math>\frac{1}{2}mv_{\max}^2</math> in <math>hf = \phi + \frac{1}{2}mv_{\max}^2</math> (1)</li> <li>Rearranges to identify gradient = <math>h/e</math> (1)</li> <li>Attempt to find gradient using large triangle (1)</li> <li><math>h = 7.6 \times 10^{-34} \text{ J s}</math> (range: <math>7.5 \times 10^{-34} \text{ J s}</math> to <math>7.7 \times 10^{-34} \text{ J s}</math>)</li> </ul>	<u>Example of calculation</u> $hf = \phi + \frac{1}{2}mv_{\max}^2$ $hf = \phi + eV$ $eV = hf - \phi$ $V = hf/e - \phi/e$ $\text{gradient} = h/e$ $\text{gradient} = (2.40 \text{ V} - 1.00 \text{ V}) \div (6.975 \times 10^{14} \text{ Hz} - 4.025 \times 10^{14} \text{ Hz})$ $\text{gradient} = 4.72 \times 10^{-34} \text{ V s}$ $h = 4.72 \times 10^{-34} \text{ V s} \times 1.6 \times 10^{-19} \text{ C}$ $h = 7.58 \times 10^{-34} \text{ J s}$	4

Q17.

Question Number	Acceptable answers	Additional guidance	Mark
(a)(i)	<ul style="list-style-type: none"> <li>Use of <math>\lambda = h/p</math> and <math>v = f\lambda</math> (1)</li> <li>Momentum of photon = <math>3.3 \times 10^{-27}</math> (N s) (1)</li> </ul>	<u>Example of calculation</u> Momentum of photon = $p = hf/c$ $= 6.63 \times 10^{-34} \text{ J s} \times 1.5 \times 10^{15} \text{ Hz} \div 3.00 \times 10^8 \text{ m s}^{-1}$ $= 3.315 \times 10^{-27} \text{ N s}$	2

Question Number	Acceptable answers	Additional guidance	Mark
(a)(ii)	<ul style="list-style-type: none"> <li>Momentum transfer = <math>6.6 \times 10^{-27}</math> (N s) (1)</li> </ul>	Ecf momentum from (i) in parts (a)(ii) and (c)	1

Question Number	Acceptable answers	Additional guidance	Mark
(b)(i)	<ul style="list-style-type: none"> <li>Use of <math>hf = \phi + \frac{1}{2} mv^2_{\text{max}}</math> (1)</li> <li>Use of <math>E_K = \frac{1}{2} mv^2</math> (1)</li> <li><math>v = 8.4 \times 10^5</math> (m s<sup>-1</sup>) (1)</li> </ul>	<u>Example of calculation</u> $hf = \phi + \frac{1}{2} mv^2_{\text{max}}$ $hf = 6.63 \times 10^{-34} \text{ J s} \times 1.5 \times 10^{15} \text{ Hz} = 9.95 \times 10^{-19} \text{ J}$ $hf - \phi = 9.95 \times 10^{-19} \text{ J} - 6.7 \times 10^{-19} \text{ J} = 3.25 \times 10^{-19} \text{ J}$ $3.25 \times 10^{-19} \text{ J} = \frac{1}{2} \times 9.11 \times 10^{-31} \text{ kg} \times v^2$ $v = 8.4 \times 10^5 \text{ m s}^{-1}$	3

Question Number	Acceptable answers	Additional guidance	Mark
(b)(ii)	<ul style="list-style-type: none"> <li>Use of <math>p = mv</math> (1)</li> <li>Momentum of photoelectron = <math>7.7 \times 10^{-25}</math> N s (1)</li> </ul>	<u>Example of calculation</u> $p = 9.11 \times 10^{-31} \text{ kg} \times 8.4 \times 10^5 \text{ m s}^{-1}$ Momentum of photoelectron = $7.68 \times 10^{-25} \text{ N s}$ MP2: Using show that value $p = 7.3 \times 10^{-25} \text{ N s}$	2

Question Number	Acceptable answers	Additional guidance	Mark
(c)	An explanation that refers to the following points: <ul style="list-style-type: none"> <li>the change in momentum of the graphene oxide is the same as the change in momentum of the photoelectron (1)</li> <li>so the (change in) momentum is much larger for the photoelectron than for the reflected photon (1)</li> </ul>	Accept converse statement and answer that is consistent with candidate's values in (a) and (b)	2

Q18.

Question Number	Acceptable Answers	Additional guidance	Mark
	<p><b>Max 6</b></p> <p><b>Similarities</b></p> <ul style="list-style-type: none"> <li>• An electron absorbs a photon Or electrons gain energy from a photon (1)</li> <li>• photons need a minimum amount of energy (1)</li> <li>• So light must be above a certain frequency (1)</li> <li>• increasing the light intensity increases the number of electrons (released per sec) (1)</li> <li>• Evidence for the particle model of light (1)</li> </ul> <p><b>Differences</b></p> <ul style="list-style-type: none"> <li>• In the photoelectric effect electrons are released from the surface (1)</li> <li>• But electrons remain within the LDR (1)</li> <li>• Photoelectric effect occurs in metals Or LDR is a semiconductor (1)</li> </ul>		<b>6</b>



## Q19.

Question Number	Acceptable answers	Additional guidance	Mark																																								
*	<p>This question assesses a student's ability to show a coherent and logically structured answer with linkages and fully-sustained reasoning.</p> <p>Marks are awarded for indicative content and for how the answer is structured and shows lines of reasoning.</p> <p>The following table shows how the marks should be awarded for indicative content.</p> <table border="1"> <thead> <tr> <th>Number of indicative marking points seen in answer</th> <th>Number of marks awarded for indicative marking points</th> <th>Max linkage mark available</th> <th>Max final mark</th> </tr> </thead> <tbody> <tr> <td>6</td> <td>4</td> <td>2</td> <td>6</td> </tr> <tr> <td>5</td> <td>3</td> <td>2</td> <td>5</td> </tr> <tr> <td>4</td> <td>3</td> <td>1</td> <td>4</td> </tr> <tr> <td>3</td> <td>2</td> <td>1</td> <td>3</td> </tr> <tr> <td>2</td> <td>2</td> <td>0</td> <td>2</td> </tr> <tr> <td>1</td> <td>1</td> <td>0</td> <td>1</td> </tr> <tr> <td>0</td> <td>0</td> <td>0</td> <td>0</td> </tr> </tbody> </table>	Number of indicative marking points seen in answer	Number of marks awarded for indicative marking points	Max linkage mark available	Max final mark	6	4	2	6	5	3	2	5	4	3	1	4	3	2	1	3	2	2	0	2	1	1	0	1	0	0	0	0	<p>The following table shows how the marks should be awarded for structure and lines of reasoning</p> <table border="1"> <thead> <tr> <th></th> <th>Number of marks awarded for structure and lines of reasoning</th> </tr> </thead> <tbody> <tr> <td>Answer shows a coherent and logical structure with linkage and fully sustained lines of reasoning demonstrated throughout</td> <td>2</td> </tr> <tr> <td>Answer is partially structured with some linkages and lines of reasoning</td> <td>1</td> </tr> <tr> <td>Answer has no linkage between points and is unstructured</td> <td>0</td> </tr> </tbody> </table> <p>Guidance on how the mark scheme should be applied: The mark for indicative content should be added to the mark for lines of reasoning. For example, an answer with five indicative marking points which is partially structured with some linkages and lines of reasoning scores 4 marks (3 marks for indicative content and 1 mark for partial structure and some linkages and lines of reasoning). If there are no linkages between points, the same five indicative marking points would yield an overall score of 3 marks (3 marks for indicative content and no marks for linkages).</p>		Number of marks awarded for structure and lines of reasoning	Answer shows a coherent and logical structure with linkage and fully sustained lines of reasoning demonstrated throughout	2	Answer is partially structured with some linkages and lines of reasoning	1	Answer has no linkage between points and is unstructured	0	
Number of indicative marking points seen in answer	Number of marks awarded for indicative marking points	Max linkage mark available	Max final mark																																								
6	4	2	6																																								
5	3	2	5																																								
4	3	1	4																																								
3	2	1	3																																								
2	2	0	2																																								
1	1	0	1																																								
0	0	0	0																																								
	Number of marks awarded for structure and lines of reasoning																																										
Answer shows a coherent and logical structure with linkage and fully sustained lines of reasoning demonstrated throughout	2																																										
Answer is partially structured with some linkages and lines of reasoning	1																																										
Answer has no linkage between points and is unstructured	0																																										
	<p>Indicative content</p> <p>Observations</p> <ul style="list-style-type: none"> <li>• Photoelectrons emitted instantaneously when radiation incident on surface</li> <li>• There is no photoemission below the threshold frequency</li> <li>• The maximum <math>k_e</math> of the photoelectrons is independent of the intensity of the incident radiation</li> <li>• The rate of photoemission is proportional to the intensity of the incident radiation</li> </ul> <p>Models</p> <ul style="list-style-type: none"> <li>• One photon is absorbed by one electron Or all of the energy of one photon is transferred to one electron</li> <li>• With waves, energy can be supplied to the electron continuously Or with waves, energy can 'build up'</li> </ul>	<p>There are 4 observations and 2 models. Linkage is demonstrated by linking observations and models.</p> <p>Two linkage marks can only be awarded if reference is made to both models and more than one observation</p>	6																																								

Q20.

Question Number	Acceptable Answer	Additional Guidance	Mark
	<ul style="list-style-type: none"> <li>work function = <math>hf_0</math> (1)</li> <li>use of <math>hf = \phi + \frac{1}{2}mv^2_{\max}</math> (1)</li> <li>division by <math>1.6 \times 10^{-19}</math> (1)</li> <li><math>V = 0.60 \text{ V}</math> (1)</li> </ul>	<p><u>Example of calculation</u></p> <p>work function = <math>hf_0</math></p> <p><math>= 6.63 \times 10^{-34} \text{ J s} \times 8.17 \times 10^{14} \text{ Hz}</math></p> <p><math>= 5.42 \times 10^{-20} \text{ J}</math></p> <p><math>\frac{1}{2}mv^2_{\max}</math></p> <p><math>= (6.63 \times 10^{-34} \text{ J s} \times 9.62 \times 10^{14} \text{ Hz}) - 5.42 \times 10^{-20} \text{ J}</math></p> <p><math>= 9.61 \times 10^{-20} \text{ J}</math></p> <p><math>V = 9.61 \times 10^{-20} \text{ J} / 1.6 \times 10^{-19} \text{ C}</math></p> <p><math>V = 0.60 \text{ V}</math></p>	(4)

Q21.

Question Number	Answer	Mark
	<p>The only correct answer is C because wave nature would predict a greater emission rate with a greater incident power</p> <p>A because instantaneous emission is only predicted by particle nature</p> <p>B because dependence of maximum kinetic energy on frequency is only predicted by particle nature</p> <p>D because minimum frequency for emission is only predicted by particle nature</p>	1

Q22.

Question Number	Acceptable Answer	Additional Guidance	Mark
	<p>The student's answer should</p> <ul style="list-style-type: none"> <li>Include the idea that 'threshold' refers to a (minimum) frequency (1)</li> <li>state that <u>photons</u> have an energy given by <math>hf</math> (1)</li> <li>recognise that the energy used to release electrons is called the <u>work function</u> (1)</li> <li>include the idea that one <u>photon</u> is absorbed by one electron (1)</li> </ul>	<p>For MP1, accept that wavelength has to be below a certain 'threshold'</p> <p><b>Max 3</b> if the response is not a discussion of the student's answer</p>	4

Q23.

Question Number	Acceptable answer	Additional guidance	Mark
	D	The only correct answer is D: a wave of greater intensity would still transfer energy at a greater rate which could release photoelectrons at a greater rate even if they could absorb energy continuously A is not correct because time would be required for absorption of sufficient wave energy B is not correct because absorption of sufficient wave energy would occur over time C is not correct because at higher intensities the waves would have higher amplitudes and energy could increase over time to higher values	1

Q24.

Question Number	Acceptable Answer	Additional Guidance	Mark
	<ul style="list-style-type: none"> <li>Light consists of (particles called) <u>photons</u> (1)</li> </ul>		
	<ul style="list-style-type: none"> <li>These particles: are discrete packets of energy Or are quanta of energy (1) Or have momentum</li> </ul>		2

Q25.

Question Number	Answer	Additional Guidance	Mark
	<ul style="list-style-type: none"> <li>one photon interacts with one electron (1)</li> <li>when the energy of the photon is equal to or greater than the work function (of the metal) an electron is released (1)</li> <li>energy of photon = <math>hf</math> so there is a minimum/threshold frequency (1)</li> </ul>		3

Q26.

Question Number	Answer	Mark
	<b>D visible line spectra</b>	1
	Incorrect Answers: A – wave model B – wave model C – wave model	

Q27.

Question Number	Acceptable Answers	Additional Guidance	Mark
	<ul style="list-style-type: none"> <li>atoms/electrons have fixed/discrete/specific energy levels (1)</li> <li>electrons get excited by absorbing <u>photons</u> (1)</li> <li>energy of <u>photon</u> absorbed = difference in energy levels (1)</li> <li>only certain transitions possible, so only certain <u>photon</u> energies absorbed so only certain frequencies missing (1)</li> <li>the set of frequencies absorbed depends on the element (1)</li> </ul>	Answers in terms of emission spectrum can be awarded MP1, 4 and 5	5

Q28.

Question Number	Acceptable answers	Additional guidance	Mark
	<p>The only correct answer is A because, using Einstein's photoelectric equation, <math>hf = \phi + \frac{1}{2}mv_{\max}^2</math>, since the work function is constant, an increase in frequency results in an increase in the maximum kinetic energy of the photoelectrons</p> <p>B is not correct because, using Einstein's photoelectric equation, <math>hf = \phi + \frac{1}{2}mv_{\max}^2</math>, intensity has no effect on the maximum kinetic energy of the photoelectrons, just the rate at which they are emitted</p> <p>C is not correct because, using Einstein's photoelectric equation, <math>hf = \phi + \frac{1}{2}mv_{\max}^2</math>, and since the work function is equal to (the Planck constant <math>\times</math> threshold frequency), a higher threshold frequency will lead to a lower maximum kinetic energy of the photoelectrons</p> <p>D is not correct because, using Einstein's photoelectric equation, <math>hf = \phi + \frac{1}{2}mv_{\max}^2</math>, a higher work function will lead to a lower maximum kinetic energy of the photoelectrons</p>		1

Q29.

Question Number	Answer	Mark
	<b>D</b>	<b>1</b>
	Incorrect Answers: A – absorption of the longest wavelength B – emission with the longest wavelength C – absorption of the shortest wavelength	

## Q30.

Question Number	Acceptable answers	Additional guidance	Mark																				
*	<p>This question assesses a student's ability to show a coherent and logically structured answer with linkages and fully-sustained reasoning.</p> <p>Marks are awarded for indicative content and for how the answer is structured and shows lines of reasoning.</p> <p>The following table shows how the marks should be awarded for indicative content.</p> <table border="1" data-bbox="355 786 743 1140"> <thead> <tr> <th>Number of indicative marking points seen in answer</th> <th>Number of marks awarded for indicative marking points</th> </tr> </thead> <tbody> <tr> <td>6</td> <td>4</td> </tr> <tr> <td>5 - 4</td> <td>3</td> </tr> <tr> <td>3 - 2</td> <td>2</td> </tr> <tr> <td>1</td> <td>1</td> </tr> <tr> <td>0</td> <td>0</td> </tr> </tbody> </table>	Number of indicative marking points seen in answer	Number of marks awarded for indicative marking points	6	4	5 - 4	3	3 - 2	2	1	1	0	0	<p>The following table shows how the marks should be awarded for structure and lines of reasoning</p> <table border="1" data-bbox="799 456 1262 976"> <thead> <tr> <th></th> <th>Number of marks awarded for structure of answer and sustained line of reasoning</th> </tr> </thead> <tbody> <tr> <td>Answer shows a coherent and logical structure with linkages and fully sustained lines of reasoning demonstrated throughout</td> <td>2</td> </tr> <tr> <td>Answer is partially structured with some linkages and lines of reasoning</td> <td>1</td> </tr> <tr> <td>Answer has no linkages between points and is unstructured</td> <td>0</td> </tr> </tbody> </table>		Number of marks awarded for structure of answer and sustained line of reasoning	Answer shows a coherent and logical structure with linkages and fully sustained lines of reasoning demonstrated throughout	2	Answer is partially structured with some linkages and lines of reasoning	1	Answer has no linkages between points and is unstructured	0	
Number of indicative marking points seen in answer	Number of marks awarded for indicative marking points																						
6	4																						
5 - 4	3																						
3 - 2	2																						
1	1																						
0	0																						
	Number of marks awarded for structure of answer and sustained line of reasoning																						
Answer shows a coherent and logical structure with linkages and fully sustained lines of reasoning demonstrated throughout	2																						
Answer is partially structured with some linkages and lines of reasoning	1																						
Answer has no linkages between points and is unstructured	0																						
	<p><b>Indicative content</b></p> <ul style="list-style-type: none"> <li>• This is a diffraction/interference pattern</li> <li>• Electrons behave as waves</li> <li>• As speed/momentum increases the circles get smaller</li> <li>• <math>n\lambda = d\sin\theta</math> used to justify that as <math>\theta</math> decreases <math>\lambda</math> decreases</li> <li>• Refers de Broglie equation (<math>\lambda = h/p</math>) to confirm that as speed/momentum increases, wavelength decreases.</li> <li>• Crystal has a regular/layered structure</li> </ul>	<p>PP2 Do not credit 'electrons behave as waves or particles' on its own PP3 accept circles get condensed for circles get smaller</p> <p>PP4 do not credit use of equation to justify <math>\lambda</math> same size as gaps in crystal or to measure the gaps in the graphite</p> <p>PP6 small gaps at uniform distances/lengths Or accept that graphite is made up of more than a single crystal</p>	6																				

## Q31.

Question Number	Acceptable answers	Additional guidance	Mark
(i)	<ul style="list-style-type: none"> <li>The electrons/atoms can only exist in discrete/specific energy levels (in the sodium atoms) (1)</li> <li>Electrons/atoms become excited Or Electrons/atoms move to higher energy levels (1)</li> <li>The electrons/atoms then move to lower energy levels, giving out energy in the form of <u>photons</u> (1)</li> <li>The energy of the photon is equal to the energy difference between the energy levels (1)</li> <li><math>E = hf</math> and <math>\lambda = c/f</math> so wavelength depends on the photon energy (1)</li> <li>There are only certain energy transitions possible (between discrete levels) so only certain frequencies/wavelengths are visible. (1)</li> </ul>	<p>accept <math>E = hc / \lambda</math></p> <p>MP6 – Allow reference to few or limited number for 'certain'. Allow reference to discrete differences in energy levels.</p>	6
(ii)	<ul style="list-style-type: none"> <li>Use of <math>n\lambda = d \sin \theta</math> (1)</li> <li><math>d = 1.77 \times 10^{-6} \text{ m}</math> (1)</li> <li>Choose <math>d = 2.0 \times 10^{-6} \text{ m}</math> as a smaller value than <math>d = 1.77 \times 10^{-6} \text{ m}</math> would cause greater diffraction angles so the third order would not be seen, but <math>3.3 \times 10^{-6} \text{ m}</math> would produce smaller angles than <math>2.0 \times 10^{-6} \text{ m}</math>, causing larger relative uncertainty in measurement (1)</li> </ul> <p>Or</p> <ul style="list-style-type: none"> <li>Use of <math>n\lambda = d \sin \theta</math></li> <li>A correct value of <math>\sin \theta</math> or <math>\theta</math>  <math>d = 1.0 \times 10^{-6} \text{ m} \rightarrow 1.77</math>  <math>d = 1.7 \times 10^{-6} \text{ m} \rightarrow 1.04</math>  <math>d = 2.0 \times 10^{-6} \text{ m} \rightarrow 0.88 \quad 62.^\circ</math>  <math>d = 3.3 \times 10^{-6} \text{ m} \rightarrow 0.535 \quad 32.^\circ</math> (1)</li> <li>Choose <math>d = 2.0 \times 10^{-6} \text{ m}</math>. <math>1.7 \times 10^{-6} \text{ m}</math> would give a sine value greater than 1, so no 3<sup>rd</sup> order is visible, and <math>3.3 \times 10^{-6} \text{ m}</math> would produce smaller angles than <math>2.0 \times 10^{-6} \text{ m}</math>, causing larger relative uncertainty in measurement (1)</li> </ul>	<p><u>Example of calculation</u>  <math>3 \times 5.89 \times 10^{-7} \text{ m} = d \sin 90^\circ</math>  <math>d = 1.77 \times 10^{-6} \text{ m}</math></p>	3

Q32.

Question Number	Acceptable Answer	Additional Guidance	Mark
(i)	<ul style="list-style-type: none"> <li>Use of <math>\frac{1}{2}m\langle c^2 \rangle = \frac{3}{2}kT</math> (1)</li> <li>mean kinetic energy = <math>6.4 \times 10^{-20} \text{ J}</math> (1)</li> </ul>	<p><u>Example of calculation:</u></p> $\frac{1}{2}m\langle c^2 \rangle = \frac{3}{2}kT$ $= \frac{3}{2} \times 1.38 \times 10^{-23} \text{ J K}^{-1} \times 3100 \text{ K} = 6.42 \times 10^{-20} \text{ J}$	2
Question Number	Acceptable Answer	Additional Guidance	Mark
(ii)	<ul style="list-style-type: none"> <li>There are electron transitions between energy levels in the atoms. (1)</li> <li>When electrons return to a lower level they emit energy in the form of <u>photons</u>. (1)</li> </ul>		2

Q33.

Question Number	Acceptable answers	Additional guidance	Mark																																																				
*	<p>This question assesses a student's ability to show a coherent and logically structured answer with linkages and fully-sustained reasoning. Total marks awarded is the sum of marks for indicative content and the marks for structure and lines of reasoning</p> <table border="1"> <thead> <tr> <th>IC points</th> <th>IC mark</th> <th>Max structure mark</th> <th>Max final mark</th> </tr> </thead> <tbody> <tr><td>6</td><td>4</td><td>2</td><td>6</td></tr> <tr><td>5</td><td>3</td><td>2</td><td>5</td></tr> <tr><td>4</td><td>3</td><td>1</td><td>4</td></tr> <tr><td>3</td><td>2</td><td>1</td><td>3</td></tr> <tr><td>2</td><td>2</td><td>0</td><td>2</td></tr> <tr><td>1</td><td>1</td><td>0</td><td>1</td></tr> <tr><td>0</td><td>0</td><td>0</td><td>0</td></tr> </tbody> </table> <p>Marks are awarded for indicative content and for how the answer is structured and shows lines of reasoning. The following table shows how the marks should be awarded for indicative content.</p> <table border="1"> <thead> <tr> <th>Number of indicative marking points seen in answer</th> <th>Number of marks awarded for indicative marking points</th> </tr> </thead> <tbody> <tr><td>6</td><td>4</td></tr> <tr><td>5-4</td><td>3</td></tr> <tr><td>3-2</td><td>2</td></tr> <tr><td>1</td><td>1</td></tr> <tr><td>0</td><td>0</td></tr> </tbody> </table> <table border="1"> <thead> <tr> <th></th> <th>Number of marks awarded for structure of answer and sustained line of reasoning</th> </tr> </thead> <tbody> <tr> <td>Answer shows a coherent and logical structure with linkages and fully sustained lines of reasoning demonstrated throughout</td> <td>2</td> </tr> <tr> <td>Answer is partially structured with some linkages and lines of reasoning</td> <td>1</td> </tr> <tr> <td>Answer has no linkages between points and is unstructured</td> <td>0</td> </tr> </tbody> </table> <p>IC5 and IC6 can be awarded if suitable equations with terms explained are used</p>	IC points	IC mark	Max structure mark	Max final mark	6	4	2	6	5	3	2	5	4	3	1	4	3	2	1	3	2	2	0	2	1	1	0	1	0	0	0	0	Number of indicative marking points seen in answer	Number of marks awarded for indicative marking points	6	4	5-4	3	3-2	2	1	1	0	0		Number of marks awarded for structure of answer and sustained line of reasoning	Answer shows a coherent and logical structure with linkages and fully sustained lines of reasoning demonstrated throughout	2	Answer is partially structured with some linkages and lines of reasoning	1	Answer has no linkages between points and is unstructured	0		6
IC points	IC mark	Max structure mark	Max final mark																																																				
6	4	2	6																																																				
5	3	2	5																																																				
4	3	1	4																																																				
3	2	1	3																																																				
2	2	0	2																																																				
1	1	0	1																																																				
0	0	0	0																																																				
Number of indicative marking points seen in answer	Number of marks awarded for indicative marking points																																																						
6	4																																																						
5-4	3																																																						
3-2	2																																																						
1	1																																																						
0	0																																																						
	Number of marks awarded for structure of answer and sustained line of reasoning																																																						
Answer shows a coherent and logical structure with linkages and fully sustained lines of reasoning demonstrated throughout	2																																																						
Answer is partially structured with some linkages and lines of reasoning	1																																																						
Answer has no linkages between points and is unstructured	0																																																						

Indicative content			
IC1	Electrons in neon atoms/molecules absorb <u>energy</u> due to electron collisions Or neon atoms/molecules absorb <u>energy</u> due to electron collisions		
IC2	Electrons in neon atoms/molecules move to higher energy levels/states Or Electrons in neon atoms/molecules are excited Or Neon atoms/molecules are excited		
IC3	A <u>photon</u> is released when an electron drops down energy levels Or A <u>photon</u> is released when an atoms/electron de-excites		
IC4	Electrons/atoms/molecules have discrete energy levels/states		
IC5	Frequency/wavelength (of emitted photon) is determined by difference in energy levels/states Or $E_2 - E_1 = hf$ where $f$ is frequency		
IC6	Limited number of possible energy levels/states, and so only certain/particular/specific frequencies/ wavelengths are emitted Or Only certain energy changes possible, and so only certain/particular/specific frequencies/ wavelengths are emitted		

## Q34.

Question Number	Acceptable Answer	Additional Guidance	Mark
	<ul style="list-style-type: none"> <li>Electrons are excited to higher energy states / levels (by incident electrons) (1)</li> <li>An electron returns to the lower energy state / level resulting in the emission of a <u>photon</u> (1)</li> <li>The energy of the photon is equal to the difference of the energy states / levels (1)</li> <li>Large difference in energy states / levels so as <math>E = hf</math>, radiation is high frequency (1)</li> </ul>	For MP1 and MP2 allow <ul style="list-style-type: none"> <li>Electrons knock electrons out of low energy levels</li> <li>Electrons cascade down to fill up the levels</li> </ul>	4



Q35.

Question Number	Acceptable answers	Additional guidance	Mark
(i)	<ul style="list-style-type: none"> <li>(Moving) electrons collide with lattice/ions (1)</li> <li>Transfer of energy to (lattice) ions so they vibrate with larger amplitude/speed (and the temperature increases) (1)</li> </ul>		2
(ii)	<ul style="list-style-type: none"> <li>Electrons/ions in the tube collide with mercury/phosphor atoms and excite electrons (in the mercury/phosphor atoms) (1)</li> <li>Energy is released in the form of photons as the electrons move back down (to the ground state) (1)</li> </ul>	Mention of work function scores 0  MP2 Allow de-excite for move back down	2

Q36.

Question Number	Answer	Mark
	C $\lambda = \frac{6.63 \times 10^{-34}}{9.11 \times 10^{-31} \times v}$	1
	Incorrect Answers: A Incorrect value for $h$ B Incorrect arrangement and incorrect value for $h$ D Incorrect arrangement	

Q37.

Question Number	Answer	Mark
	B ground state to level 2	1
	Incorrect Answers: A – incorrect change in energy C – incorrect change in energy and direction D – incorrect direction	

Q38.

Question Number	Acceptable Answer	Additional Guidance	Mark
	<ul style="list-style-type: none"> <li>• the atoms have discrete energy levels (1)</li> <li>• atoms gain energy and get excited / electrons move to higher energy levels (1)</li> <li>• atoms/electrons move to lower energy levels and emit energy as photons (1)</li> <li>• <u>different</u> energy changes cause photons with <u>different</u> frequencies/wavelengths (1)</li> </ul>		<b>(4)</b>

Q39.

Question Number	Acceptable answers	Additional guidance	Mark
*	<p>This question assesses a student's ability to show a coherent and logically structured answer with linkages and fully-sustained reasoning.</p> <p>Marks are awarded for indicative content and for how the answer is structured and shows lines of reasoning.</p> <p>The following table shows how the marks should be awarded for indicative content.</p>	<p>Guidance on how the mark scheme should be applied: The mark for indicative content should be added to the mark for lines of reasoning. For example, an answer with five indicative marking points which is partially structured with</p>	

Number of indicative marking points seen in answer	Number of marks awarded for indicative marking points
6	4
5 - 4	3
3 - 2	2
1	1
0	0

The following table shows how the marks should be awarded for structure and lines of reasoning.

	Number of marks awarded for structure of answer and sustained line of reasoning
Answer shows a coherent and logical structure with linkages and fully sustained lines of reasoning demonstrated throughout	2
Answer is partially structured with some linkages and lines of reasoning	1
Answer has no linkages between points and is unstructured	0

**Indicative content**

- electrons/atoms move to higher energy levels  
**Or** electrons/atoms are excited
- they then move to lower energy levels (accept ground state) and the energy (from the change) is given out in the form of a photon

some linkages and lines of reasoning scores 4 marks (3 marks for indicative content and 1 mark for partial structure and some linkages and lines of reasoning). If there are no linkages between points, the same five indicative marking points would yield an overall score of 3 marks (3 marks for indicative content and no marks for linkages).

(6)

	<ul style="list-style-type: none"> <li>• the energy levels are discrete <b>Or</b> only certain energy levels are possible</li> <li>• the energy of the photon is <u>equal</u> to the difference in energy levels <b>Or</b> <math>hf = E_2 - E_1</math> <b>Or</b> <math>hc/\lambda = E_2 - E_1</math></li> <li>• there are only a limited number of energy differences and only a corresponding set of frequencies/wavelengths</li> <li>• different elements have different energy level (differences), so they will produce different frequencies/wavelengths</li> </ul>	looking for energy differences /changes <b>not</b> energy levels	
--	--	---	--

Q40.

Question Number	Answer	Mark
	<b>D</b> shortest arrow pointing to ground state	<b>1</b>
	Incorrect Answers: A – shortest wavelength absorbed B – longest wavelength absorbed C – shortest wavelength emitted	

Q41.

Question Number	Acceptable Answers	Additional Guidance	Mark
	<ul style="list-style-type: none"> <li>• use of difference in energy levels in eV and use of <math>W = QV</math> for conversion to Joule (1)</li> <li>• use of <math>E = hf</math> (1)</li> <li>• frequency = <math>7.2 \times 10^{13}</math> Hz (1)</li> </ul>	Example of calculation:  difference in energy levels $= -0.55 \text{ eV} - (-0.85 \text{ eV}) = 0.3 \text{ eV}$ $= 0.3 \text{ V} \times 1.6 \times 10^{-19} \text{ C} = 4.8 \times 10^{-20} \text{ J}$ $f = 4.8 \times 10^{-20} \text{ J} / 6.63 \times 10^{-34} \text{ Js}$ $= 7.2 \times 10^{13} \text{ Hz}$	<b>3</b>

Q42.

Question Number	Acceptable answers	Additional guidance	Mark
	<ul style="list-style-type: none"> <li>• Use of <math>E = hf</math> and <math>c = f\lambda</math> (1)</li> <li>• Convert J to eV (1)</li> <li>• 2.1 eV (1)</li> <li>• Arrow drawn on diagram from -3.04 eV to -5.14 eV (1)</li> </ul>	<u>Example of calculation</u>  $E = 6.63 \times 10^{-34} \text{ Js} \times 3.00 \times 10^8 \text{ m s}^{-1} / 5.89 \times 10^{-7} \text{ m}$ $= 3.38 \times 10^{-19} \text{ J}$ $3.38 \times 10^{-19} \text{ J} / 1.60 \times 10^{-19} \text{ C} = 2.11 \text{ eV}$	<b>4</b>

Q43.

Question Number	Answer	Additional Guidance	Mark
	<p>electron falls back down energy levels emitting a photon (1)</p> <p>wavelength (of photon) is inversely proportional to the energy change (1)</p> <p>refers to energy transition <math>n=3</math> to <math>n=2</math> or <math>n=2</math> to <math>n=1</math> (1)</p>		3

Q44.

Question Number	Answer	Mark
	C	1

Q45.

Question Number	Answer	Mark
	<b>A – amount of energy of a photon needed to release an electron</b>	1
	<p>Incorrect Answers:</p> <p>B- an electron does not release a photon</p> <p>C – reference to frequency incorrect</p> <p>D - reference to frequency incorrect and electron does not release a photon</p>	

Q46.

Question Number	Acceptable answers	Additional guidance	Mark
	<ul style="list-style-type: none"> <li>Use of <math>E_K = p^2 / 2m</math> (1)</li> <li>Use of <math>\lambda = h/p</math> (1)</li> <li><math>\lambda = 5.0 \times 10^{-11}</math> (m) calculated from <math>E_K</math> (1) Or <math>E_K = 9.7 \times 10^{-17}</math> (J) calculated from <math>\lambda = 5.0 \times 10^{-11}</math> m Or <math>p = 1.3 \times 10^{-23}</math> (kg m s<sup>-1</sup>) calculated from <math>E_K</math> and <math>p = 1.3 \times 10^{-23}</math> (kg m s<sup>-1</sup>) calculated from <math>\lambda = 5.0 \times 10^{-11}</math> m</li> <li>path difference at X is <math>\lambda/2</math> Or path difference at Y is <math>\lambda</math> (1)</li> <li>(electron) waves at X are in antiphase Or (electron) waves at Y are in phase (1)</li> <li>at X destructive interference/superposition takes place Or at Y constructive interference/superposition takes place (1)</li> </ul>	<p>MP1 accept use of <math>p = mv</math> and Use of <math>E_k = \frac{1}{2} mv^2</math></p> <p>MP4 accept <math>(n + \frac{1}{2}) \lambda</math> or <math>n \lambda</math> respectively</p> <p><u>Example of calculation</u>  <math>p = \sqrt{(2 \times 9.11 \times 10^{-31} \text{ kg} \times 9.6 \times 10^{-17} \text{ J})}</math>  <math>p = 1.32 \times 10^{-23} \text{ kg m s}^{-1}</math>  <math>\lambda = 6.63 \times 10^{-34} \text{ Js} / 1.32 \times 10^{-23} \text{ kg m s}^{-1}</math>  <math>\lambda = 5.0 \times 10^{-11} \text{ m}</math></p>	6

Q47.

Question Number	Acceptable Answer	Additional Guidance	Mark
	<ul style="list-style-type: none"> <li>Photoelectric equation stated in words (1) Or <math>hf = \phi + \frac{1}{2} mv_{\text{max}}^2</math> with <math>\phi</math> defined</li> <li>Hence <math>eV_s = hf - \phi</math> (1) Or <math>E_{k \text{ max}} = hf - \phi</math> and <math>E_{k \text{ max}} = eV_s</math></li> <li>Compare with <math>y = mx + c</math> (1)</li> <li>So plot a graph of <math>V_s</math> against <math>f</math> (1) Or plot a graph of <math>eV_s</math> against <math>f</math></li> <li>Gradient = <math>\frac{h}{e}</math> (1) Or gradient = <math>h</math></li> </ul>	<p>MP1: Accept <math>hf_0</math> for <math>\phi</math> [with <math>f_0</math> defined], and <math>E_{k \text{ max}}</math> for <math>\frac{1}{2} mv_{\text{max}}^2</math></p> <p>MP2: <math>eV_s</math> does not have to be the subject of the equation</p> <p>MP5 is dependent upon MP4</p>	5

Q48.

Question Number	Acceptable answers	Additional guidance	Mark
(a)	the lowest frequency (of incident radiation) that will cause the emission of (photo)electrons (from the surface)		(1)
Question Number	Acceptable answers	Additional guidance	Mark
(b)	<ul style="list-style-type: none"> <li>• use of <math>\frac{1}{2} m v_{\max}^2</math> (1)</li> <li>• use of <math>\phi = hf - \text{max ke}</math> (1)</li> <li>• divides energy in joule by <math>1.6 \times 10^{-19} \text{ C}</math> (1)</li> <li>• <math>\phi = 2.4 \text{ eV}</math> (1)</li> </ul>	<p><u>Example of calculation:</u>  <math>E = 6.63 \times 10^{-34} \text{ J s} \times 8.9 \times 10^{14} \text{ Hz} = 5.9 \times 10^{-19} \text{ J}</math></p> $\frac{1}{2} m v_{\max}^2 = \frac{1}{2} \times 9.11 \times 10^{-31} \text{ kg} \times (6.7 \times 10^5 \text{ m s}^{-1})^2 = 2.045 \times 10^{-19} \text{ J}$ $\phi = 5.9 \times 10^{-19} \text{ J} - 2.045 \times 10^{-19} \text{ J} = 3.8 \times 10^{-19} \text{ J}$ $= 1.8 \times 10^{-19} \text{ J} \div 1.6 \times 10^{-19} \text{ C}$ $= 2.4 \text{ eV}$	(4)

Q49.

Question Number	Acceptable Answer	Additional Guidance	Mark
	<ul style="list-style-type: none"> <li>• The deflection/fields experiments indicate that electrons have a mass (and a charge) (1)</li> <li>Or the deflection/fields experiments indicate that electrons have particle behaviour. (1)</li> <li>• The diffraction experiments indicate that electrons must have a wave nature (1)</li> <li>• Idea that a model of electron behaviour must include wave-particle duality (1)</li> </ul>	In MP1 allow a description of deflection e.g. electrons are deflected by (electric and magnetic) fields indicating that they have a mass (and charge)	3

Q50.

Question Number	Answer	Additional Guidance	Mark
	<ul style="list-style-type: none"> <li>Use of <math>\lambda = \frac{h}{p}</math></li> </ul> <p>Either</p> <ul style="list-style-type: none"> <li><math>h = 6.7 \times 10^{-34}</math> (J s)</li> <li>compares answer to <math>6.63 \times 10^{-34}</math> (J s)</li> </ul> <p>Or</p> <ul style="list-style-type: none"> <li><math>\lambda = 1.38 \times 10^{-10}</math> (m)</li> <li>compares answer to <math>1.40 \times 10^{-10}</math> (m)</li> </ul>	<p><u>Example of calculation</u></p> $h = 1.4 \times 10^{-10} \text{ m} \times 4.8 \times 10^{-24} \text{ kg m s}^{-1}$ $h = 6.7 \times 10^{-34} \text{ J s} \approx 6.63 \times 10^{-34} \text{ J s}$	3

Q51.

Question Number	Acceptable answers	Additional guidance	Mark
	<ul style="list-style-type: none"> <li>Use of gradient (1)</li> <li><math>h</math> from graph = <math>6.74 \times 10^{-34}</math> J s (1)</li> <li>Suitable percentage calculation allowing comparison with 1% and conclusion (1)</li> </ul>	<p><u>Example of calculation</u></p> <p>gradient = <math>3.00 \times 10^{-19}</math> J ÷  <math>(10.15 \times 10^{14} \text{ Hz} - 5.70 \times 10^{14} \text{ Hz})</math>  <math>h = 6.74 \times 10^{-34}</math> J s</p> <p>percentage difference  <math>= (6.74 \times 10^{-34} \text{ J s} - 6.63 \times 10^{-34} \text{ J s})</math>  <math>/ 6.63 \times 10^{-34} \text{ J s} \times 100\%</math>  <math>= 1.66\%</math> which is greater than 1% so it is not within 1%</p> <p>Or  <math>6.63 \times 10^{-34} \text{ J s} \times 101\% = 6.70 \times 10^{-34} \text{ J s}</math>  which is smaller than <math>6.74 \times 10^{-34}</math> J s so it is not within 1%</p>	3

Q52.

Question Number	Acceptable Answers	Additional guidance	Mark
	<ul style="list-style-type: none"> <li>Use of <math>p = mv</math> using mass of electron (1)</li> <li>Use of <math>\lambda = \frac{h}{p}</math> (1)</li> <li><math>\lambda = 3.3 \times 10^{-11}</math> m (1)</li> </ul>	<p><u>Example of Calculation</u></p> $\lambda = \frac{6.63 \times 10^{-34} \text{ J s}}{9.11 \times 10^{-31} \text{ kg} \times 2.2 \times 10^7 \text{ m s}^{-1}}$ $\lambda = 3.3 \times 10^{-11} \text{ m}$	3



Q53.

Question Number	Acceptable Answers	Additional Guidance	Mark
	<ul style="list-style-type: none"> <li>• Electrons exist in discrete energy levels (1)</li> <li>• (After the mercury atom is excited) electrons move back to a lower energy level (1) Or (After the mercury atom is excited) electrons move back down from a higher energy level</li> <li>• Photons are emitted (1)</li> <li>• Frequency of emitted radiation / photons depends on the difference in energy between the energy levels (1) Or reference to <math>\Delta E = hf</math></li> <li>• Since there are only certain energy changes possible, only certain frequencies are possible (1)</li> </ul>	Accept excited state for higher energy level Accept ground state for lower energy state	5

Q54.

Question Number	Acceptable Answers	Additional guidance	Mark
(i)	<ul style="list-style-type: none"> <li>• Use of <math>\lambda = \frac{h}{p}</math> (1)</li> <li>• recognise <math>\lambda = 2 \times</math> diameter of atom (1)</li> <li>• <math>1.7 \times 10^{-24} \text{ kg m s}^{-1}</math> (1)</li> </ul>	<u>Example of calculation</u> $p = \frac{6.63 \times 10^{-24} \text{ (J s)}}{2 \times 2.0 \times 10^{-10} \text{ (m)}} = 1.67 \times 10^{-24} \text{ kg m s}^{-1}$	3
(ii)	<ul style="list-style-type: none"> <li>• A discrete number of half wavelengths fit into the diameter of an atom (1)</li> <li>• Reference to <math>E = \frac{hc}{\lambda}</math> to link wavelength to discrete energy levels (1)</li> </ul>		2

Q55.

Question Number	Answer	Mark				
	A Using $n\lambda = d \sin \theta$	1				
	<table border="1"> <tr> <td>Number of slits per mm in the diffraction grating</td> <td>Wavelength of the light source</td> </tr> <tr> <td>Increased</td> <td>Increased</td> </tr> </table>		Number of slits per mm in the diffraction grating	Wavelength of the light source	Increased	Increased
Number of slits per mm in the diffraction grating	Wavelength of the light source					
Increased	Increased					
	Incorrect Answers: B – wavelength decreasing would cause $d$ to decrease C – number of slits/mm decreasing would cause $d$ to decrease D – both decreasing causes $d$ to decrease					

Q56.

Question Number	Acceptable answers	Additional guidance	Mark
	<ul style="list-style-type: none"> <li>• Line of best fit drawn (1)</li> <li>• Gradient determined (1)</li> <li>• Applies eV to J conversion factor (1)</li> <li>• <math>h = 6.62 \times 10^{-34} \text{ J s}</math> (<math>6.4 \times 10^{-34} \text{ J s}</math> to <math>6.8 \times 10^{-34} \text{ J s}</math>) (1)</li> </ul> MP4 dependent on calculation from graph	<u>Example of calculation</u> Gradient = $4.14 \times 10^{-15}$ $h = 4.14 \times 10^{-15} \text{ eV s} \times 1.6 \times 10^{-19} \text{ J eV}^{-1}$ $h = 6.62 \times 10^{-34} \text{ J s}$	4

Q57.

Question Number	Acceptable answers	Additional guidance	Mark
	<ul style="list-style-type: none"> <li>• <math>x</math>-intercept determined (1)</li> <li>• Use of <math>\phi = hf_0</math> (1)</li> <li>• <math>\phi = 2.3 \text{ eV}</math>, so metal is (probably) caesium (allow ecf for <math>h</math> from (a)) (1)</li> </ul> OR <ul style="list-style-type: none"> <li>• Reads a pair of co-ordinates from graph</li> <li>• Use of <math>\phi = hf - E</math></li> <li>• <math>\phi = 2.3 \text{ eV}</math>, so metal is (probably) caesium (allow ecf for <math>h</math> from (a))</li> </ul>	MP2: allow use of standard value for $h$ or value of $h$ determined in (a)  <u>Example of calculation</u> $f_0 = 55 \times 10^{13} \text{ Hz}$ $\phi = 6.62 \times 10^{-34} \text{ J s} \times 55 \times 10^{13} \text{ Hz}$ $= 3.64 \times 10^{-19} \text{ J}$ $\phi = \frac{3.64 \times 10^{-19} \text{ J}}{1.6 \times 10^{-19} \text{ J eV}^{-1}} = 2.28 \text{ eV}$	3