

Interference and Diffraction

Q1.

In an experiment to determine the wavelength of light, a diffraction grating is illuminated with light from a monochromatic source. A series of bright spots is observed.

The experiment is repeated and the distance between consecutive bright spots increases.

Select the row of the table that gives two changes to the experimental set up which would both cause the distance between consecutive bright spots to increase.

(1)

	Number of slits per mm in the diffraction grating	Wavelength of the light source
<input type="checkbox"/> A	Increased	Increased
<input type="checkbox"/> B	Increased	Decreased
<input type="checkbox"/> C	Decreased	Increased
<input type="checkbox"/> D	Decreased	Decreased

(Total for question = 1 mark)

Q2.

In 1905 Einstein published his equation for the photoelectric effect.

In 1916 Millikan demonstrated that the maximum kinetic energy of photoelectrons is consistent with Einstein's equation.

Millikan used a device known as a monochromator to ensure that a single wavelength of light was used to illuminate the surface of the lithium.

A monochromator separates wavelengths using a diffraction grating.

Calculate the angle at which a diffraction grating would produce the most intense line at a single wavelength of 6.1×10^{-7} m.

number of lines per mm for grating = 600 mm^{-1}

(3)

.....

.....

.....

.....

.....

.....

Angle =

(Total for question = 3 marks)

Q3.

Read the extract and answer the question that follows.

In the 17th century there were two proposed theories to explain the refraction of light. Using a wave model, Huygens stated that light slows down when it passes from air to water. Using a particle model, Newton stated that light speeds up when it passes from air to water. Newton's theory was more readily accepted until the speed of light in water was measured in the 19th century.

In the early 20th century, Einstein used observations from the photoelectric effect to provide evidence for the particle model of light.

Nowadays, both the wave model of light and the particle model of light are accepted, as each can be used to explain different aspects of the behaviour of light.

Diffraction and interference can be explained using the wave model of light.

In an investigation to determine the wavelength of light from a laser, the light passed through a diffraction grating with 300 lines per millimetre.

A diffraction pattern consisting of a series of bright dots was observed on a screen.

The following data were recorded:

distance between grating and screen = 2.00 m

distance from central maximum to 2nd order maximum = 89.0 cm.

Calculate the wavelength of light from the laser.

(3)

.....

.....

.....

.....

.....

Wavelength =

(Total for question = 3 marks)

Q4.

Light from a laser pointer was passed through a diffraction grating. The light was perpendicular to the diffraction grating as shown. A diffraction pattern was produced on a screen.

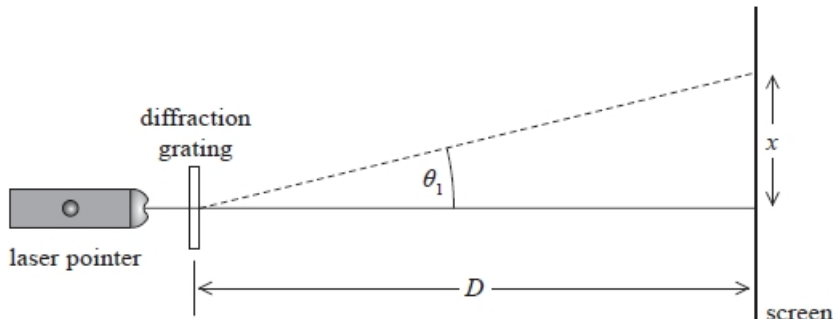

The distance between the first order maximum and the central maximum of the diffraction pattern was x . The distance between the diffraction grating and the screen was D .

Distance x was measured to be 0.500 m with a metre rule. The wavelength of light λ_1 from the laser pointer was 650 nm.

The laser pointer was replaced with one that produced light of a different wavelength. The new distance x was measured to be 0.400 m.

$D = 1.45 \text{ m}$

Calculate the wavelength λ_2 of the light emitted by the replacement laser pointer.

(5)

.....

.....

.....

.....

.....

.....

.....

.....

.....

.....

.....

$\lambda_2 = \dots\dots\dots$

(Total for question = 5 marks)

Q5.

In a spectrometer, light from a tube of hot gas is passed through a diffraction grating.

The diagram shows the zero order and the first order maxima for the line spectrum produced.

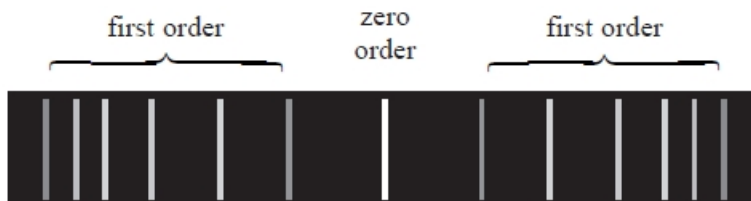

(a) The spectrometer measures the angles between the different lines and the zero order. One of the lines has a wavelength of 650 nm and is observed, in the first order spectrum, at an angle of 19.9° from the zero order.

Calculate the number of lines per metre of the diffraction grating.

(3)

.....

.....

.....

.....

.....

Number of lines per metre =

(b) Explain one precaution that could be taken to ensure the accuracy of the measurement of the angle.

(2)

.....

.....

.....

.....

Q6.

A beam of light from a laser is directed at a diffraction grating.

The diagram shows the positions of the central maximum and the first order maxima on a screen.

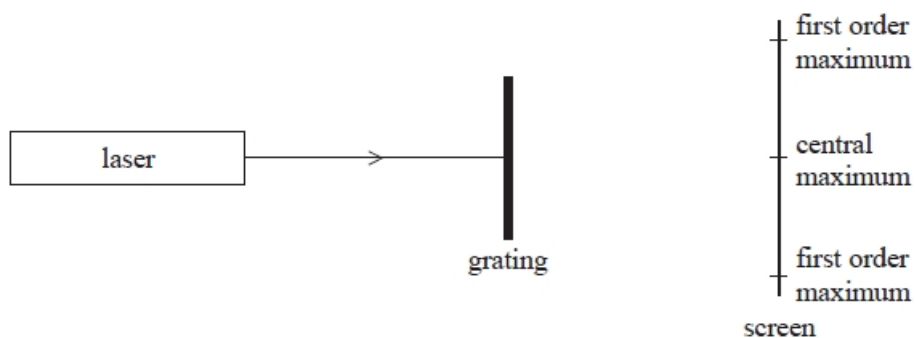

Which of the following would cause the first order maxima to be closer to the central maximum on the screen?

(1)

- A** moving the laser closer to the grating
- B** moving the screen further from the grating
- C** using a grating with more lines per metre
- D** using laser light with a higher frequency

(Total for question = 1 mark)

Q7.

For two waves of light to be coherent the waves must

(1)

- A** always have a phase difference equal to 0.
- B** oscillate in the same plane.
- C** have a similar amplitude.
- D** originate from one source.

(Total for question = 1 mark)

Q8.

The arrangement shown was used to determine the wavelength of light emitted by a laser.

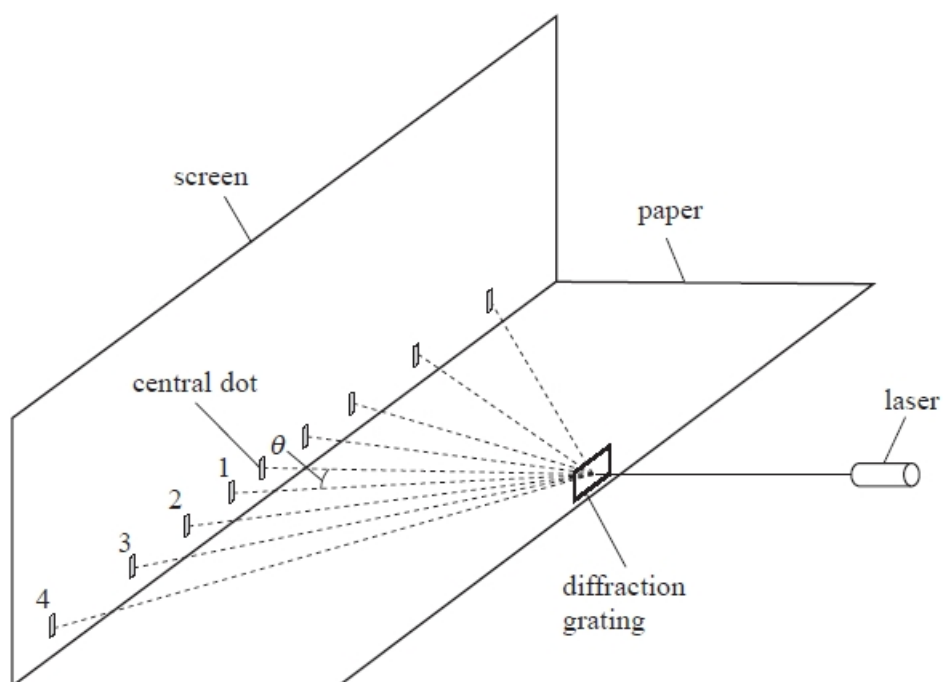

A laser light beam was shone at a diffraction grating. A series of dots of light was produced on a screen. The angles θ between the light ray to the central dot and the light rays to the dots labelled 1 to 4 were measured with a protractor.

n	$\theta / ^\circ$	$\sin \theta$
1	12	0.21
2	23	0.39
3	34	0.56
4	51	0.78

Describe how the angle θ could be determined without using a protractor.

(2)

.....

.....

.....

.....

(Total for question = 2 marks)

Q9.

The arrangement shown was used to determine the wavelength of light emitted by a laser.

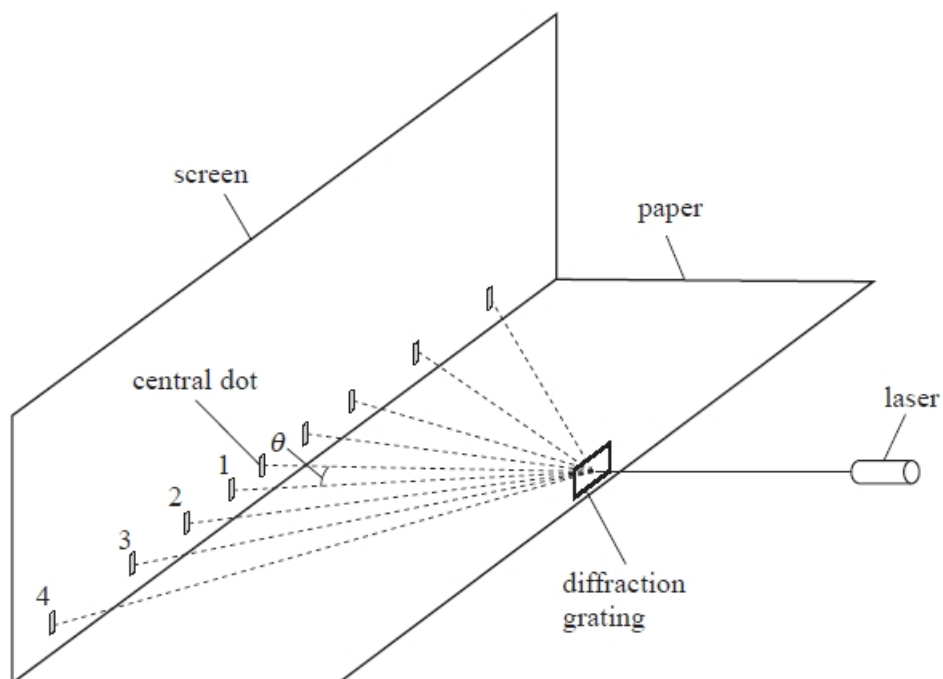

A laser light beam was shone at a diffraction grating. A series of dots of light was produced on a screen. The angles θ between the light ray to the central dot and the light rays to the dots labelled 1 to 4 were measured with a protractor.

n	$\theta / ^\circ$	$\sin \theta$
1	12	0.21
2	23	0.39
3	34	0.56
4	51	0.78

(a) Describe how the angle θ could be determined without using a protractor.

(2)

.....

.....

.....

.....

(b) Plot a graph of n against $\sin\theta$ on the grid below.

(4)

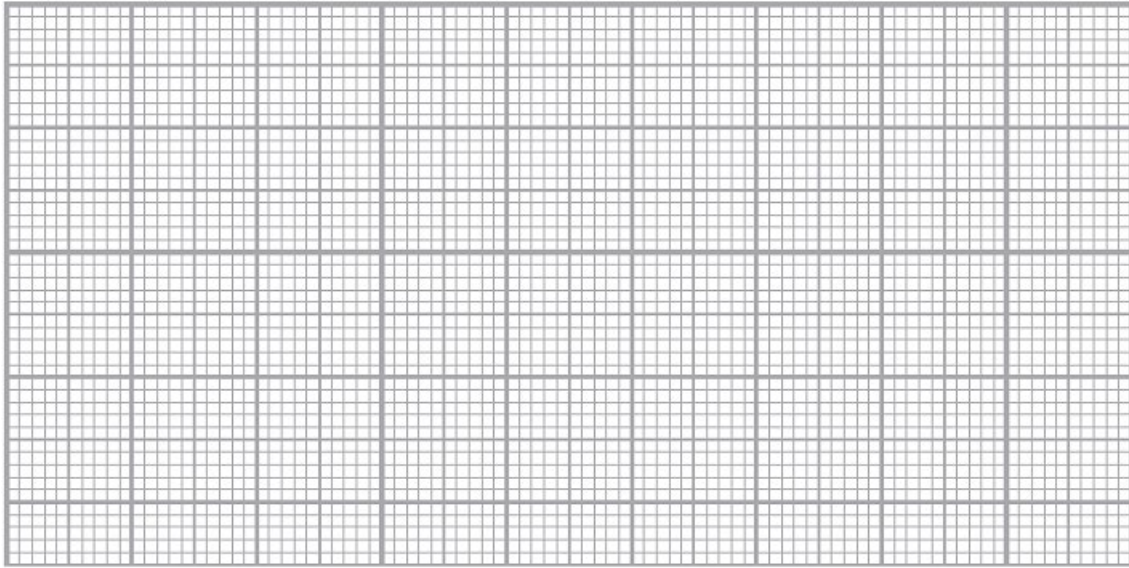

(c) The diffraction grating has $300 \text{ lines mm}^{-1}$.

Determine the wavelength of the laser light.

(4)

.....

.....

.....

.....

.....

.....

.....

.....

.....

.....

Wavelength =

(Total for question = 10 marks)

Q10.

The arrangement shown was used to determine the wavelength of light emitted by a laser.

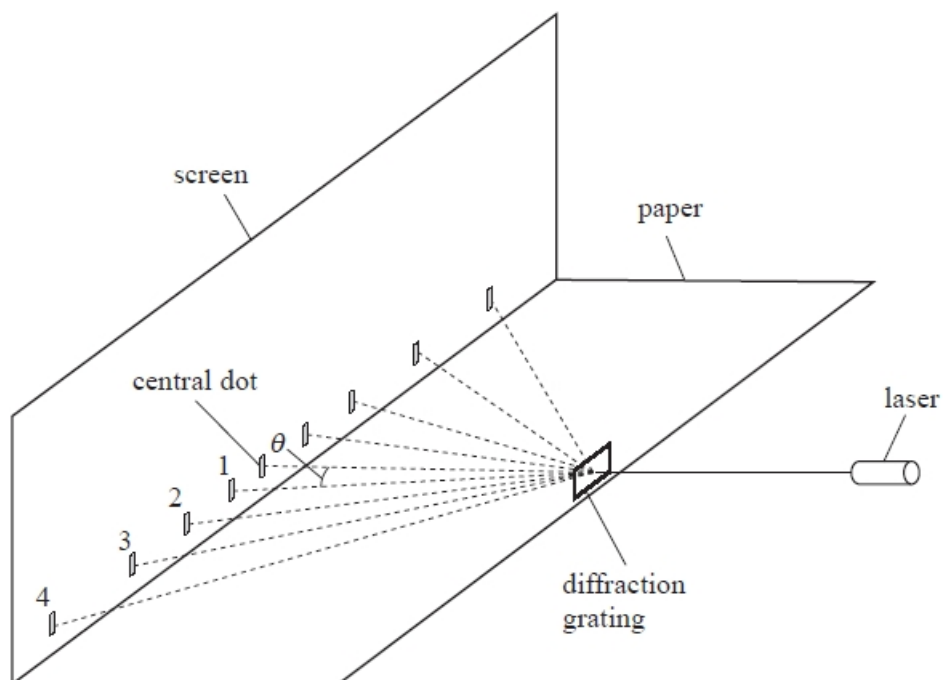

A laser light beam was shone at a diffraction grating. A series of dots of light was produced on a screen. The angles θ between the light ray to the central dot and the light rays to the dots labelled 1 to 4 were measured with a protractor.

n	$\theta / ^\circ$	$\sin \theta$
1	12	0.21
2	23	0.39
3	34	0.56
4	51	0.78

The diffraction grating has $300 \text{ lines mm}^{-1}$.

Determine the wavelength of the laser light.

(4)

.....

.....

.....

.....

.....

.....

.....

Wavelength =

(Total for question = 4 marks)

Q11.

The experiment was carried out with laser light of wavelength 600 nm. The diagram below shows two paths taken by the light after it has passed through the two slits A and B. The diagram is not to scale.

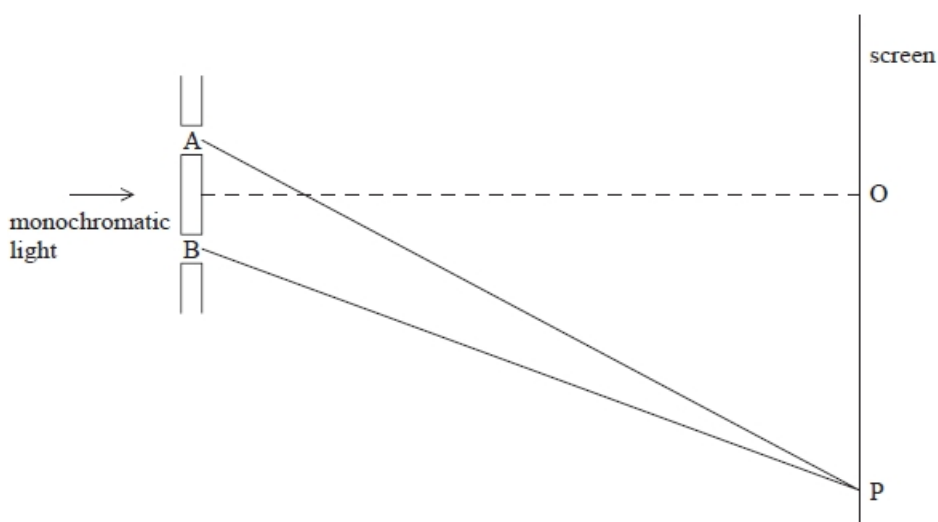

- (i) Point O is a point equidistant from the two slits.
 Explain why there is a bright line at this point.

(3)

.....

- (ii) The next bright line is observed on the screen at point P. Lines AP and BP show the path of the light from each slit to the screen at P.
 State the difference in the lengths of the paths AP and BP.

(1)

Difference in lengths of paths =

(Total for question = 4 marks)

Q12.

Barnard's star is a red dwarf star in the vicinity of the Sun. The wavelength of a line in the spectrum of light emitted from Barnard's star is measured to be 656.0 nm. The same light produced by a source in a laboratory has a wavelength of 656.2 nm.

A diffraction grating can be used to analyse the radiation emitted by a variety of sources.

(i) A diffraction grating of known grating spacing is used in a school laboratory to analyse the light emitted by a laser.

Describe how the diffraction grating is used and the measurements that should be taken.

(3)

.....

.....

.....

.....

.....

.....

.....

.....

.....

.....

(ii) A diffraction grating with grating spacing of 2.2×10^{-6} m is used to determine the difference in wavelength for the spectral line emitted by Barnard's star.

Comment on the suitability of using a diffraction grating with this spacing. You should include appropriate calculations.

(4)

.....

.....

.....

.....

.....

.....

.....

.....

.....

.....

(Total for question = 7 marks)

Q13.

In everyday life the effect of diffraction is more significant for sound than for light.

This is because

- A** light has a much shorter wavelength than sound.
- B** light is a transverse wave but sound is a longitudinal wave.
- C** light is an electromagnetic wave but sound is a mechanical wave.
- D** the speed of light in air is much higher than the speed of sound.

(Total for question = 1 mark)

Q14.

Sound waves can diffract around obstacles as shown in the diagram.

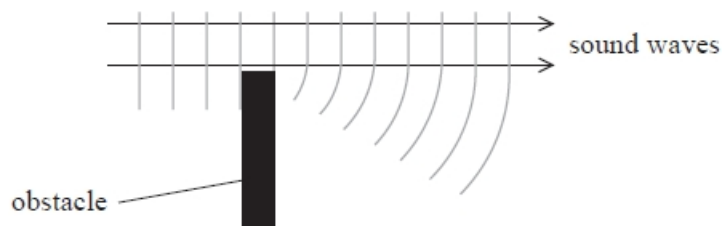

The diffraction effect is

- A** greater for large amplitude sound waves.
- B** greater for low frequency sound waves.
- C** independent of the frequency of the sound waves.
- D** independent of the speed of the sound waves.

(Total for question = 1 mark)

Q15.

A student obtains the following diffraction pattern on a wall by shining a red laser beam through a single narrow slit.

The corresponding graph of intensity against position is shown below.

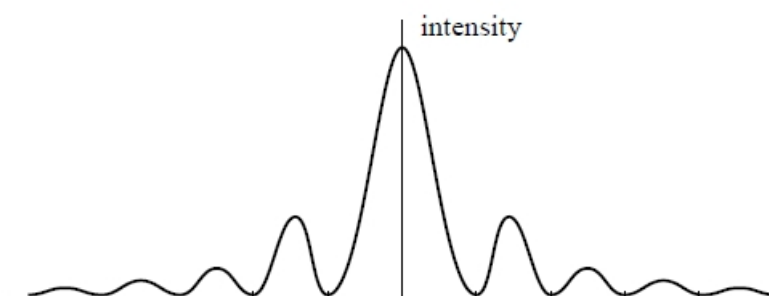
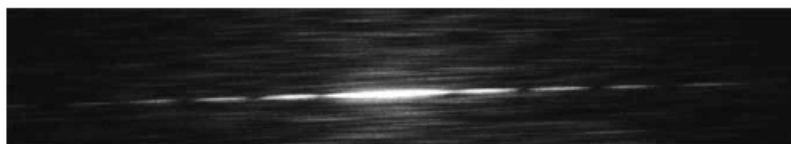

(a) Explain how the diffraction pattern is created.

(3)

.....

.....

.....

.....

.....

.....

(b) Explain how the pattern would differ if green laser light were used instead of red laser light.

(3)

.....

.....

.....

.....

.....

.....

(c) A student replaces the single slit with a diffraction grating and obtains the pattern shown in the photograph.



The photograph shows the zero order maximum and the first and second orders on either side.

The student takes measurements to determine the grating spacing.

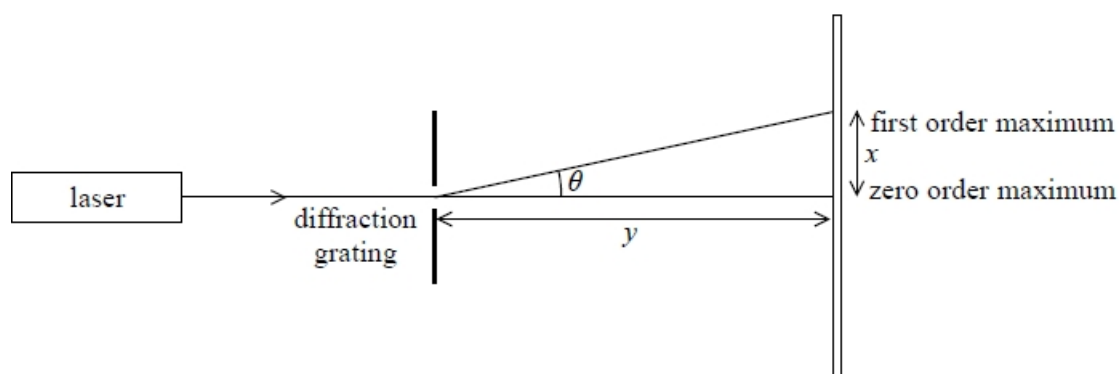

The student measures x , the distance between the zero order maximum and the first order maximum, and y , the distance between the slit and the screen.

$$x = 23 \text{ cm}$$

$$y = 1.5 \text{ m}$$

$$\text{Number of lines per millimetre} = 300$$

Calculate the wavelength of light from the laser.

(3)

.....

.....

.....

.....

.....

.....

Wavelength =

(Total for question = 9 marks)

Q16.

The diffraction of light provides evidence for the wave theory of light.

A student carried out an investigation to determine the wavelength of the light emitted from a laser pen.

He shone the light from the laser pen so that it was incident perpendicularly on a diffraction grating. The diffraction grating had 200 lines per mm. He observed the diffraction pattern on a screen 3.00 m away from the grating. The pattern consisted of a series of bright dots.



(i) Give a reason why a laser is a suitable source of light to produce a diffraction pattern.

(1)

.....

.....

(ii) The student measured a distance of 102 cm between the central maximum and the centre of a third order maximum.

The table shows the range of wavelengths for each colour of the visible spectrum.

Colour	Range of wavelength / nm
violet	380–450
blue	450–495
green	495–570
yellow	570–590
orange	590–620
red	620–750

Deduce the colour of the light emitted from the laser pen.

(5)

.....

.....

.....

.....

.....

.....

.....

.....

.....

.....

.....

(Total for question = 6 marks)

Q18.

A method to determine the wavelength of light using a converging lens was first proposed by Sir Isaac Newton.

A converging lens is placed on a plane glass plate. The lens is illuminated from above with a parallel beam of monochromatic light, as shown.

Some of the light is reflected from the upper surface of the lower glass plate and some from the lower surface of the lens. Interference between these two reflected waves produces circular fringes. The pattern is viewed through a microscope.

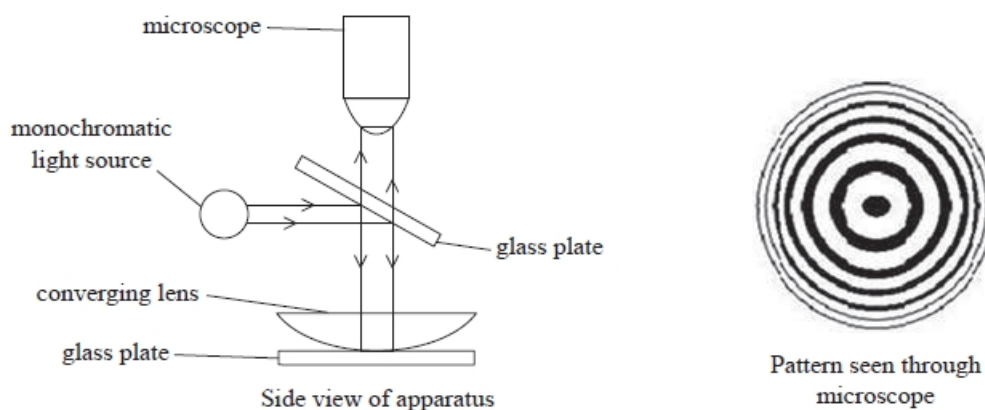

When considering the principles of this experiment, a student suggests that interference fringes would only be produced with monochromatic light. This is because interference requires coherent light waves.

Discuss the validity of the student's suggestion.

(4)

.....

.....

.....

.....

.....

.....

.....

.....

.....

.....

.....

(Total for question = 4 marks)

Q19.

The diagram shows a coherent beam of light incident on a metal ball bearing.

A dark shadow is seen on a screen behind the ball bearing. There is a small spot of light in the centre of the shadow. This spot of light is known as the Arago spot.

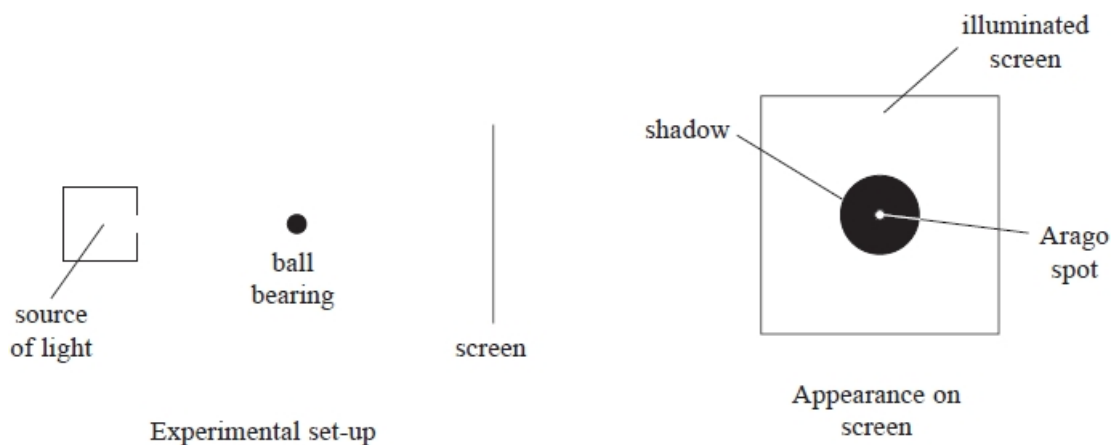

(a) Use Huygens' construction to explain the behaviour of light as it travels past the edge of the ball bearing.

(2)

.....

.....

.....

.....

(b) Explain why a spot of light is produced at the centre of the shadow.

(3)

.....

.....

.....

.....

.....

.....

(Total for question = 5 marks)

Q20.

Light can be modelled as a wave.

Diffraction provides evidence for the wave nature of light.

Use Huygens' construction to describe what happens to light waves after passing through a narrow gap.

(3)

.....

.....

.....

.....

.....

(Total for question = 3 marks)

Q21.

Read the extract and answer the question that follows.

In the 17th century there were two proposed theories to explain the refraction of light. Using a wave model, Huygens stated that light slows down when it passes from air to water. Using a particle model, Newton stated that light speeds up when it passes from air to water. Newton's theory was more readily accepted until the speed of light in water was measured in the 19th century.

In the early 20th century, Einstein used observations from the photoelectric effect to provide evidence for the particle model of light.

Nowadays, both the wave model of light and the particle model of light are accepted, as each can be used to explain different aspects of the behaviour of light.

A ray of light travelling in air is incident on some water with an angle of incidence of 35° . The angle of refraction is 26° .

Deduce whether this is consistent with Huygens' statement about the speed of light as it passes from air to water. Your answer should include a calculation.

(3)

.....

.....

.....

.....

.....

.....

(Total for question = 3 marks)

Q22.

Read the extract and answer the question that follows.

In the 17th century there were two proposed theories to explain the refraction of light. Using a wave model, Huygens stated that light slows down when it passes from air to water. Using a particle model, Newton stated that light speeds up when it passes from air to water. Newton's theory was more readily accepted until the speed of light in water was measured in the 19th century.

In the early 20th century, Einstein used observations from the photoelectric effect to provide evidence for the particle model of light.

Nowadays, both the wave model of light and the particle model of light are accepted, as each can be used to explain different aspects of the behaviour of light.

Give two reasons why Huygens' theory for the refraction of light eventually became accepted.

(2)

.....

.....

.....

.....

.....

.....

(Total for question = 2 marks)

Q23.

Details supplied with a school microwave transmitter and receiver include the following information:

<p>Transmitter supplies a 10 GHz polarised EM wave.</p> <p>Receiver detects EM waves in a single plane containing the direction of propagation, producing an audible output proportional to the microwave intensity.</p>
--

A student uses the microwave transmitter and receiver to investigate interference using the set-up shown.

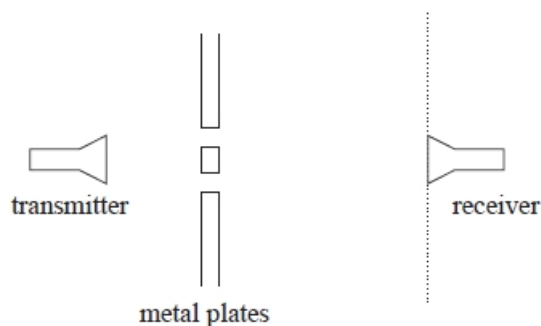

As the receiver is moved along the dotted line, alternate points of maximum and minimum intensity are detected.

Explain why points of maximum and minimum intensity are detected.

(4)

.....

.....

.....

.....

.....

.....

.....

.....

.....

.....

.....

(Total for question = 4 marks)

Q24.

Plane wavefronts pass through a gap in a barrier. The gap is much smaller than the wavelength of the wave.

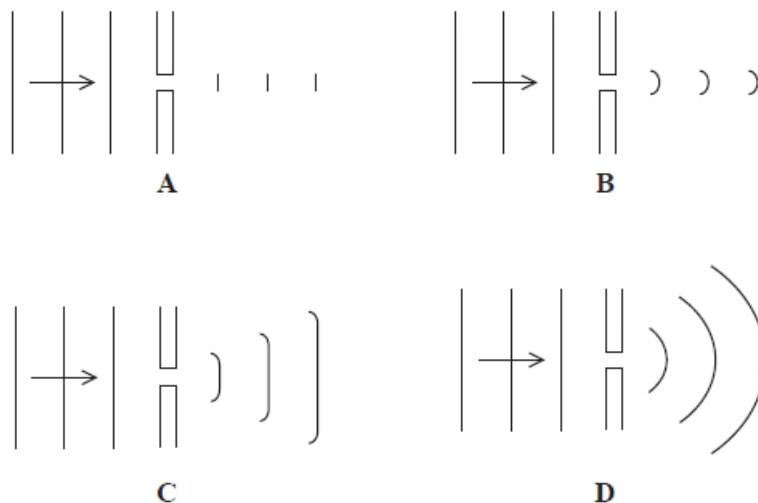

Which diagram best shows the resultant shape of the wavefronts?

- A
- B
- C
- D

(Total for question = 1 mark)

Q25.

In a concert hall, sound waves produced by an instrument are reflected from different parts of the hall. Two coherent sound waves meet at a point where their phase difference is π .

What is the smallest possible path difference to produce this phase difference?

- A $\lambda / 4$
- B $\lambda / 2$
- C $3 \lambda / 4$
- D λ

(Total for question = 1 mark)

Q26.

A stationary interference pattern is created by the superposition of waves from two sources which are close together.

For this to occur the waves must

- A** be in phase with each other.
- B** be transverse.
- C** have the same amplitude.
- D** have the same frequency.

(Total for question = 1 mark)

Q27.

Huygens' principle states that every point on a wavefront is a source of wavelets which spread out at the same speed.

State what is meant by a wavefront.

(1)

.....

.....

(Total for question = 1 mark)

Q28.

A monochromatic beam of light of wavelength λ from a laser is directed at a diffraction grating of line spacing d .

A student calculates the value of d/λ in order to determine the expected number of visible maxima.

The calculated value of d/λ is 4.7

How many maxima are visible?

- A** 4
- B** 5
- C** 9
- D** 11

(Total for question = 1 mark)

Q29.

Read the passage and answer the question that follows.

Atoms can be promoted into an excited state when they absorb energy. This results in the release of radiation at a random time. When several atoms are close together a quantum effect can occur. When one atom emits radiation this affects all the other nearby excited atoms. The excess energy of many of the atoms is released simultaneously and an intense flash of light is produced. This effect is called superradiance and can be used to produce lasers that emit a narrower range of frequencies than conventional lasers.

Superradiant lasers are highly monochromatic.

Explain why a monochromatic light source is important in diffraction experiments.

(3)

.....

.....

.....

.....

.....

(Total for question = 3 marks)

Q30.

In an experiment to determine the speed of sound in air a student connected two microphones to an oscilloscope, as shown.

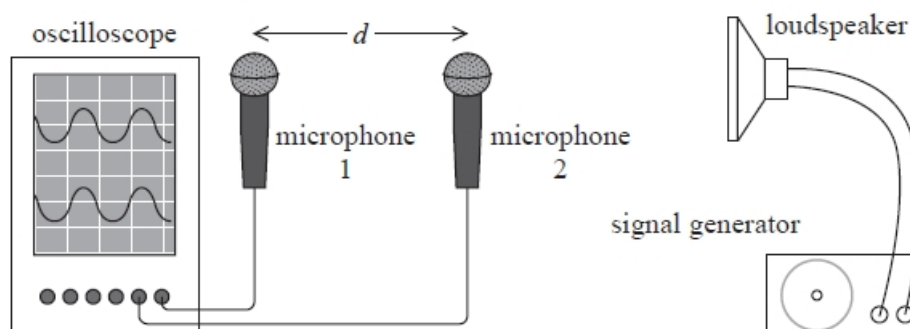

The microphones detect sound from the loudspeaker, converting it to an electrical signal. The signal is displayed on the oscilloscope screen.

Both microphones were initially positioned the same distance from the loudspeaker. The two signals were in phase on the oscilloscope screen. The student slowly moved microphone 2 towards the loudspeaker, until the two signals on the oscilloscope were in phase again. He then measured the distance d between the microphones to determine the wavelength λ of the sound waves.

$d = 20.5\text{cm}$

The oscilloscope trace for the signal from microphone 1 is shown below.

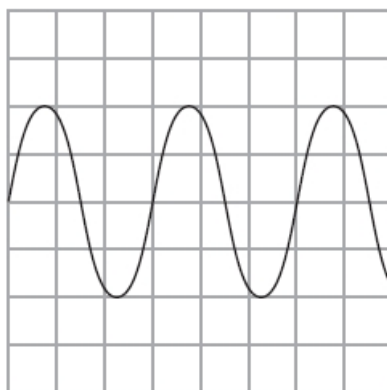

The time base of the oscilloscope was set to 0.20 ms div^{-1} .

Determine a value for the speed of sound in air.

(5)

.....

.....

.....

.....

.....

.....

.....

.....

.....

.....

.....

Speed of sound =

(Total for question = 5 marks)

Q31.

The photograph shows an ultrasonic mouse repeller used in a house.



The mouse repeller produces ultrasound that repels mice but cannot be heard by humans. The mouse hears ultrasound directly and by reflection from the walls.

The mouse repeller produces ultrasound of frequency 26.0 kHz.

speed of sound = 340 m s^{-1}

A student makes the following suggestion.

"If the ultrasound reflects off a wall directly opposite the mouse repeller a standing wave is formed, so there will be areas in the room where the mice will not hear the ultrasound."

Evaluate this suggestion.

(6)

.....

.....

.....

.....

.....

.....

.....

.....

.....

.....

.....

.....

.....

.....

.....

.....

.....

.....

.....

.....

.....

(Total for question = 6 marks)

Q32.

A student used a diffraction grating to determine the wavelength of the light emitted by a laser. Light from the laser passed through the diffraction grating and the student observed a pattern on a wall 4 m away. The pattern consisted of a central maximum and 1st and 2nd order maxima as shown.

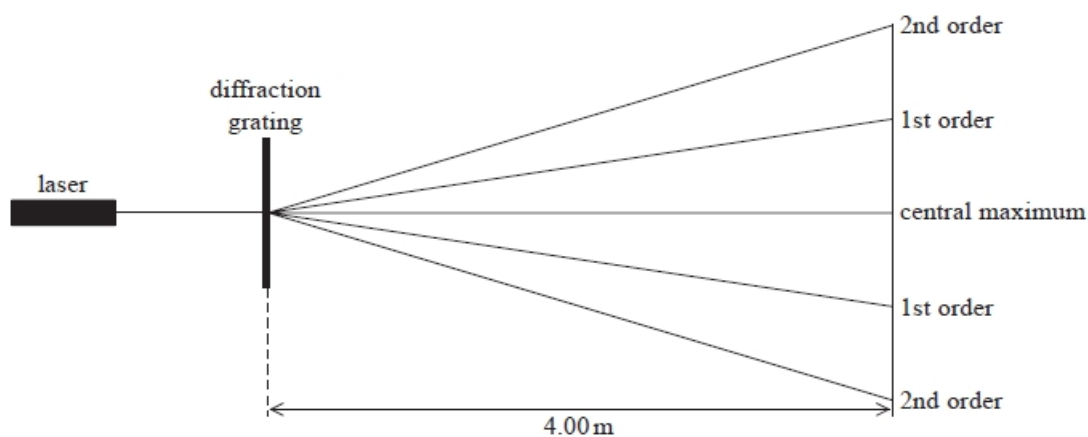

The student measured the distance between the central and a 2nd order maximum as 1350 mm. The diffraction grating had 300 slits mm^{-1} .

Measuring the distance between the two 2nd order maxima would produce a smaller percentage uncertainty in the value of wavelength.

Give a reason why.

(1)

.....

.....

.....

(Total for question = 1 mark)

Q33.

Read the following press release and then answer the question that follows.

"Lockheed Martin Demonstrates Weapons Grade High Power Fiber Laser

BOTHELL, Wash., Jan. 28, 2014 – Lockheed Martin has demonstrated a 30-kilowatt electric fiber laser, the highest power ever documented while retaining beam quality and electrical efficiency.

The internally funded research and development program culminated in this demonstration, which was achieved by combining many fiber lasers into a single, near-perfect quality beam of light – all while using approximately 50 percent less electricity than alternative solid-state laser technologies. The unique process, called Spectral Beam Combining, sends beams from multiple fiber laser modules, each with a unique wavelength, into a combiner that forms a single, powerful, high quality beam."

(Source: Lockheed Martin Demonstrates Weapons Grade High Power Fiber Laser Wash Bothell, Jan 28, 2014)

Traditional solid state lasers convert about 20% of electrical input energy to light output.

The high power laser uses Spectral Beam Combining involving several beams with different wavelengths instead of a system using coherent beams.

Explain how combining coherent beams could lead to zero intensity in some parts of the combined beam.

(3)

.....

.....

.....

.....

.....

.....

(Total for question = 3 marks)

Q34.

A two-beam oscilloscope is used to display signals from two microphones as shown.

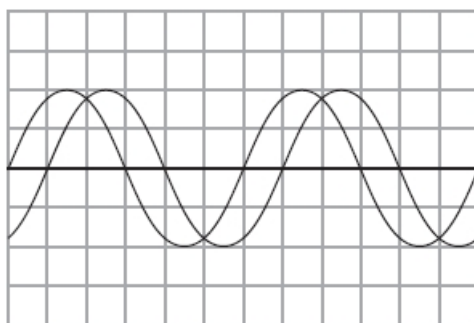

Which of the following could be the phase difference in radians between the traces?

- A $\frac{\pi}{6}$
- B $\frac{\pi}{4}$
- C $\frac{\pi}{3}$
- D $\frac{\pi}{2}$

(Total for question = 1 mark)

Q35.

* The photograph shows a pipe organ in a concert hall.



(Source: www.yucatanliving.com/article-photos/news/01042010/pipe-organ.jpg)

When the organ is played, sound travels through the air to a person in the audience as a wave. It is found that there are some positions in the concert hall where particular frequencies are quieter than others.

Explain why this might be the case and give an action that could be taken to eliminate this problem.

.....

.....

.....

.....

.....

.....

.....

.....

.....

.....

.....

(Total for question = 6 marks)

Q36.

The photograph shows an ultrasonic mouse repeller used in a house.



The mouse repeller produces ultrasound that repels mice but cannot be heard by humans. The mouse hears ultrasound directly and by reflection from the walls.

The mouse repeller produces ultrasound of frequency 26.0 kHz.

speed of sound = 340 m s^{-1}

State what is meant by superposition of waves.

(2)

.....

.....

.....

.....

(Total for question = 2 marks)

Q37.

Light from a laser pointer was passed through a diffraction grating. The light was perpendicular to the diffraction grating as shown. A diffraction pattern was produced on a screen.

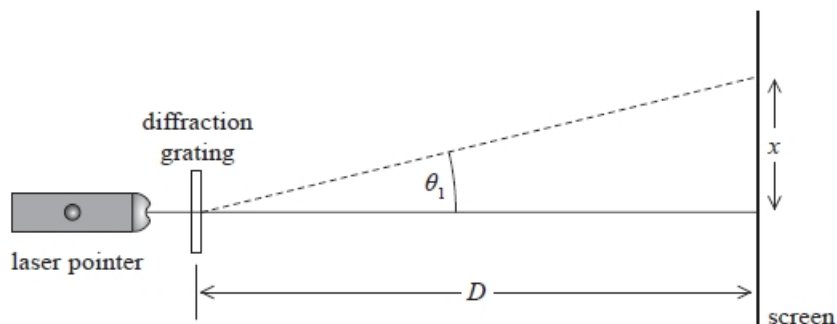

The distance between the first order maximum and the central maximum of the diffraction pattern was x . The distance between the diffraction grating and the screen was D .

In another experiment, the light from the laser pointer was not quite perpendicular to the screen.

Explain how this would change the diffraction pattern produced on the screen.

(3)

.....

.....

.....

.....

.....

.....

(Total for question = 3 marks)

Q38.

Light from a laser pointer was passed through a diffraction grating. The light was perpendicular to the diffraction grating as shown. A diffraction pattern was produced on a screen.

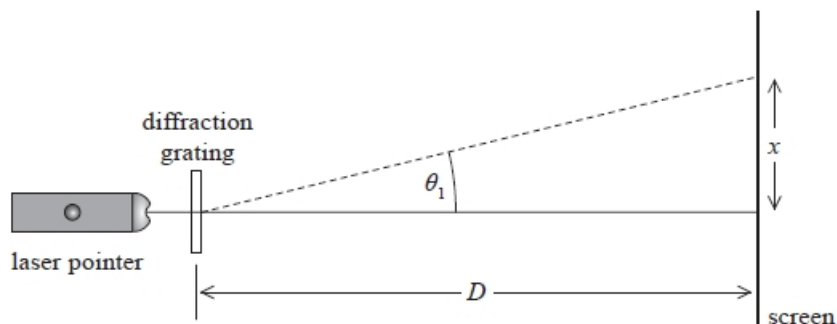

The distance between the first order maximum and the central maximum of the diffraction pattern was x . The distance between the diffraction grating and the screen was D .

Distance x was measured to be 0.500 m with a metre rule. The wavelength of light λ_1 from the laser pointer was 650 nm.

The laser pointer was replaced with one that produced light of a different wavelength. The new distance x was measured to be 0.400 m.

$$D = 1.45 \text{ m}$$

Explain one modification to this method that would decrease the uncertainty in the calculated value of λ_2 .

(2)

.....

.....

.....

.....

.....

(Total for question = 2 marks)

Q39.

The diagram shows a coherent beam of light incident on a metal ball bearing.

A dark shadow is seen on a screen behind the ball bearing. There is a small spot of light in the centre of the shadow. This spot of light is known as the Arago spot.

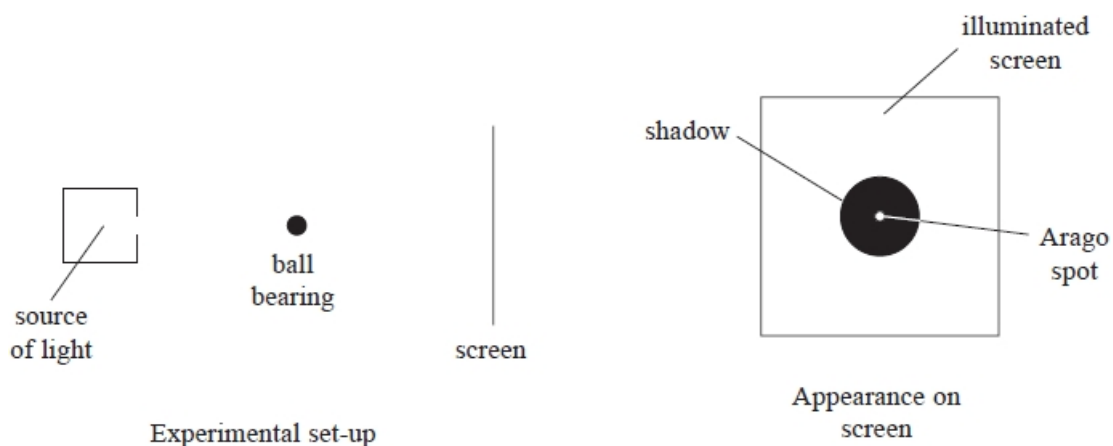

François Arago first demonstrated this experiment in 1818 for a group of eminent scientists, to show the behaviour of light.

State the model for the behaviour of light that this experiment demonstrated and explain why the scientific community accepted this model.

(3)

.....

.....

.....

.....

.....

(Total for question = 3 marks)

Q40.

The diffraction of light provides evidence for the wave theory of light.

The diagram represents wavefronts of light, incident at a single slit. The points labelled A, B and C are points on the wavefront that has just passed through the gap.

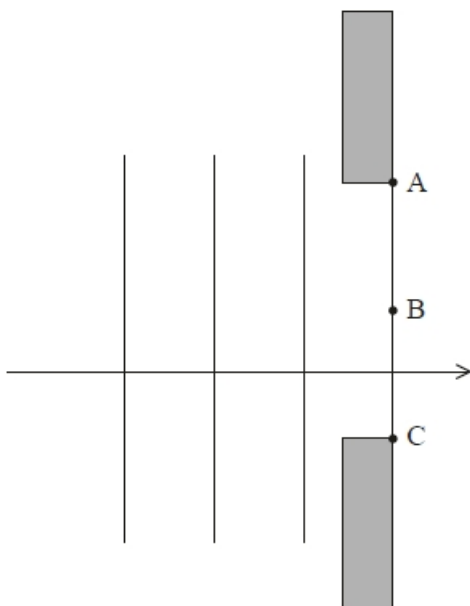

(i) Describe what is meant by a wavefront.

(1)

.....

.....

(ii) Add to the diagram to show how Huygens' construction can be used to determine the shape of the next wavefront, after the wave has passed through the gap.

(3)

(Total for question = 4 marks)

Q41.

A student used a diffraction grating to determine the wavelength of the light emitted by a laser. Light from the laser passed through the diffraction grating and the student observed a pattern on a wall 4 m away. The pattern consisted of a central maximum and 1st and 2nd order maxima as shown.

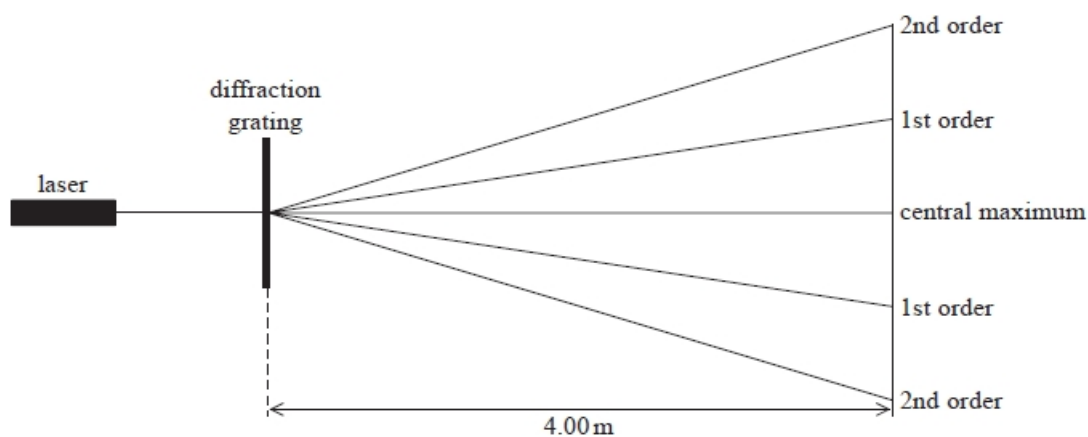

The student measured the distance between the central and a 2nd order maximum as 1350 mm. The diffraction grating had $300 \text{ slits mm}^{-1}$.

The colours and corresponding wavelengths of light emitted by commonly used lasers are given in the table.

blue	450–490 nm
green	520–560 nm
red	635–700 nm

Deduce the colour of the laser light the student used in this experiment.

(4)

.....

.....

.....

.....

.....

.....

.....

.....

(Total for question = 4 marks)

Mark Scheme – Interference and Diffraction

Q1.

Question Number	Answer	Mark				
	A Using $n\lambda = d \sin \theta$	1				
	<table border="1"> <tr> <td>Number of slits per mm in the diffraction grating</td> <td>Wavelength of the light source</td> </tr> <tr> <td>Increased</td> <td>Increased</td> </tr> </table>		Number of slits per mm in the diffraction grating	Wavelength of the light source	Increased	Increased
Number of slits per mm in the diffraction grating	Wavelength of the light source					
Increased	Increased					
	Incorrect Answers: B – wavelength decreasing would cause d to decrease C – number of slits/mm decreasing would cause d to decrease D – both decreasing causes d to decrease					

Q2.

Question Number	Acceptable answers	Additional guidance	Mark
	<ul style="list-style-type: none"> Use of $d = 1 / \text{no of slits per metre}$ (1) Use of $n\lambda = d \sin \theta$ (1) $\theta = 21^\circ$ (1) 	<u>Example of calculation</u> $d = 1 / 600\,000 = 1.67 \times 10^{-6} \text{ m}^{-1}$ $n = 1$ $6.1 \times 10^{-7} \text{ m} = 1.67 \times 10^{-6} \text{ m}^{-1} \sin \theta$ $\theta = 21.47^\circ$	3

Q3.

Question Number	Answer	Additional Guidance	Mark
	<ul style="list-style-type: none"> calculates $\theta = 24^\circ$ and $d = 3.3 \times 10^{-6} \text{ m}$ use of $n\lambda = d \sin \theta$ $6.7 - 6.8 \times 10^{-7} \text{ m}$ 	<u>Example of calculation</u> $\tan \theta = \frac{0.89 \text{ m}}{2.0 \text{ m}} \quad \theta = 24^\circ$ $d = \frac{1 \times 10^{-3}}{300} = 3.3 \times 10^{-6} \text{ m}$ $\lambda = \frac{3.3 \times 10^{-6} \text{ m} \times \sin 24}{2} = 678 \text{ nm}$	3

Q4.

Question Number	Acceptable Answer	Additional Guidance	Mark
	<ul style="list-style-type: none"> Use of trigonometry to determine θ (1) Calculation of both angles (1) Use of $d \sin\theta = n\lambda_1$ to calculate d (1) Use of $d \sin\theta = n\lambda_2$ with d (1) $\lambda_2 = 5.3 \times 10^{-7} \text{ m}$ (530 nm) 	<p><u>Example of calculation</u></p> $\tan \theta = \frac{0.50 \text{ m}}{1.45 \text{ m}} \therefore \theta = 19.0^\circ$ $\tan \theta = \frac{0.40 \text{ m}}{1.45 \text{ m}} \therefore \theta = 15.4^\circ$ $d = \frac{650 \times 10^{-9} \text{ m}}{\sin 19.0^\circ} = 1.99 \times 10^{-6} \text{ m}$ $\lambda_2 = 1.99 \times 10^{-6} \text{ m} \times \sin 15.4^\circ = 5.29 \times 10^{-7} \text{ m}$	5

Q5.

Question Number	Acceptable Answer	Additional Guidance	Mark
(a)	<ul style="list-style-type: none"> use of $n\lambda = d \sin\theta$ (1) use of $1/d$ (1) 520 000 lines per metre (1) 	<p><u>Example calculation</u></p> $d = 650 \times 10^{-9} \text{ m} / \sin 19.9^\circ = 1.9 \times 10^{-6} \text{ m}$ $1 / 1.9 \times 10^{-6} \text{ m} = 520 \text{ 000 lines per metre}$	(3)

Question Number	Acceptable Answer	Additional Guidance	Mark
(b)	<ul style="list-style-type: none"> measure angle for first order on either side and divide by 2 (1) if there is a zero error it will be eliminated (1) <p><u>OR</u></p> <ul style="list-style-type: none"> measure a larger angle (1) this will reduce the percentage uncertainty (1) 		(2)

Q6.

Question Number	Answer	Mark
	D – using laser light with a higher frequency	1
	Incorrect Answers: A – this would have no effect B – this would make the maxima further from the central maximum C – this would make the maxima further from the central maximum	

Q7.

Question Number	Answer	Mark
	D originate from one source	1
	Incorrect Answers: A – coherence requires a constant phase difference not necessarily 0 B – planes not relevant C – amplitude not relevant	

Q8.

Question Number	Acceptable answers	Additional guidance	Mark
	<ul style="list-style-type: none"> measure distance from grating to screen l and from centre to dot x (1) use $\tan \theta = x / l$ to determine θ (1) 		2

Q9.

Question Number	Acceptable answers	Additional guidance	Mark
	<ul style="list-style-type: none"> measure distance from grating to screen l and from centre to dot x (1) use $\tan \theta = x / l$ to determine θ (1) 		2

Question Number	Acceptable answers	Additional guidance	Mark
	<ul style="list-style-type: none"> Axes with labels (1) scales (1) plots (1) line of best fit (1) 	MP2: scales only in 1,2,4,5 and must cover at least half of paper MP3: a 2 mm square tolerance, check all points	4

Question Number	Acceptable answers	Additional guidance	Mark
	<ul style="list-style-type: none"> calculation of a gradient (1) use gradient = d/λ (1) use $d = 0.001 / 300$ (1) wavelength = 6.3×10^{-7} m (1) 	<u>Example of calculation</u> $\text{gradient} = \frac{4.0}{0.76} = 5.26$ $\frac{0.001}{300} = 5.26 \times \lambda$ wavelength = 6.3×10^{-7} m	4

Q10.

Question Number	Acceptable answers	Additional guidance	Mark
	<ul style="list-style-type: none"> calculation of a gradient (1) use gradient = d/λ (1) use $d = 0.001 / 300$ (1) wavelength = 6.3×10^{-7} m (1) 	<p><u>Example of calculation</u></p> $\text{gradient} = \frac{4.0}{0.76} = 5.26$ $\frac{0.001}{300} = 5.26 \times \lambda$ <p>wavelength = 6.3×10^{-7} m</p>	4

Q11.

Question Number	Acceptable Answers	Additional guidance	Mark
(i)	<p>An explanation that makes reference to the following:</p> <ul style="list-style-type: none"> Path lengths (A-O and B-O) are equal Or Path difference is zero (1) Will arrive in phase Or phase difference is zero (1) (Bright line is position of) <u>constructive</u> interference/superposition (1) 		3
(ii)	<ul style="list-style-type: none"> 600 nm Or 600×10^{-9} m Or 6.0×10^{-7} m Or one wavelength Or λ (1) 	<p>Do not accept ($n\lambda$)</p> <p>Accept any correct equivalent value</p>	1

Q12.

Question Number	Acceptable Answer	Additional Guidance	Mark
(i)	<ul style="list-style-type: none"> • set up diffraction grating at right angles to light from laser (1) Or set up grating parallel to screen • measure the distance between the diffraction grating and the screen (1) • measure the distance between 1st order images on the screen (1) 	<p>An annotated diagram could score these marks</p> <p>MP3 accept between other correct specified orders.</p>	3

Question Number	Acceptable Answer	Additional Guidance	Mark
(ii)	<ul style="list-style-type: none"> • use of $d \sin \theta = n\lambda$ (1) • Calculation of one of the diffraction angles (for any n) (1) • Attempt to calculate a difference in the angles (1) Or statement that the two angles are very similar • So (accurate) measurement would be very difficult (1) Or the difference in wavelength could not be determined with this grating 	<p>MP4 dependent on MP3</p> <p><u>Example of calculation:</u></p> $\sin \theta_1 = \frac{656.2 \times 10^{-9} \text{ m}}{2.2 \times 10^{-6} \text{ m}}$ $\therefore \theta_1 = 17.354^\circ$ $\sin \theta_2 = \frac{656.0 \times 10^{-9} \text{ m}}{2.2 \times 10^{-6} \text{ m}}$ $\therefore \theta_2 = 17.348^\circ$ $\therefore \Delta\theta = 17.354^\circ - 17.348^\circ = 0.006^\circ$	4

Q13.

Question Number	Acceptable Answers	Additional Guidance	Mark
	A		1

Q14.

Question Number	Answers	Mark
	<p>The only correct answer is B</p> <p><i>A is incorrect because amplitude does not affect the diffraction effect</i></p> <p><i>C is incorrect because frequency affects the wavelength and hence the diffraction effect</i></p> <p><i>D is incorrect because the speed of sound affects the wavelength and hence the diffraction effect</i></p>	1

Q15.

Question Number	Acceptable Answers	Additional Guidance	Mark
(a)	<p>An explanation that makes reference to:</p> <ul style="list-style-type: none"> waves/light passing through a narrow gap spread/s out (1) light reaches the wall from each part of the slit with differing phase relationships (1) OR light reaches the wall from each part of the slit with differing path lengths (1) when the waves meet superposition takes place and if the waves are in antiphase it results in destructive interference so a dark spot is seen (1) OR when the waves meet superposition takes place and if the waves are in phase it results in constructive interference so a bright(er) region is seen (1) 	Accept relevant reference to Huygen's construction for first mark.	3
(b)	<p>An explanation that makes reference to:</p> <ul style="list-style-type: none"> green light has a shorter wavelength than red light (1) OR red light has a longer wavelength than green light (1) so green light diffracts less than red light or red light diffracts more than green light (1) so the dark points would be closer to the centre or more dark points would be seen in the same space on the wall or central fringe narrower (1) 	<p>Accept a diagram clearly to the same scale and showing a narrowed pattern.</p> <p>MP2 and MP3 may be awarded if reference is made to frequency difference rather than wavelength.</p>	3
(c)	<ul style="list-style-type: none"> use of trigonometrical functions to calculate θ (1) calculate diffraction grating spacing (1) wavelength = 5.1×10^{-7} m (1) 	<p>Example of calculation:</p> $\theta = \tan^{-1}(0.23 \text{ m}/1.5 \text{ m}) = 8.7^\circ$ $d = 10^{-3}/300 = 3.3 \times 10^{-6} \text{ m}$ $\lambda = 3.3 \times 10^{-6} \text{ m} \times \sin 8.7^\circ = 5.1 \times 10^{-7} \text{ m}$	3

Q16.

Question Number	Acceptable Answers	Additional guidance	Mark
(i)	<p>Any one</p> <ul style="list-style-type: none"> Monochromatic or small range of wavelength / frequencies Coherent Little divergence of wave over a distance Produces plane wavefronts 		1
(ii)	<ul style="list-style-type: none"> $d = 0.005$ mm or use of $d = \frac{1}{200 \text{ mm}^{-1}}$ (1) Use of \tan to find θ (1) Use of $n\lambda = d \sin \theta$ with $n = 3$ (1) $\lambda = 5.4 \times 10^{-7}$ (m) (1) Concludes that the laser light is green (1) Or conclusion consistent with their value of λ 	<p><u>Example of Calculation</u></p> $d = \frac{1}{200 \text{ mm}^{-1}} = 0.005 \text{ mm}$ $\theta = \tan^{-1}\left(\frac{1.02 \text{ m}}{3.0 \text{ m}}\right) = 18.8^\circ$ $\lambda = \frac{(5 \times 10^{-6} \text{ m}) \times \sin 18.8^\circ}{3} = 5.37 \times 10^{-7} \text{ m}$ <p>so light is green</p>	5

Q17.

Question Number	Acceptable Answer	Additional Guidance	Mark												
*	<p>This question assesses a student's ability to show a coherent and logically structured answer with linkages and fully-sustained reasoning.</p> <p>Marks are awarded for indicative content and for how the answer is structured and shows lines of reasoning.</p> <p>The following table shows how the marks should be awarded for indicative content.</p> <table border="1" data-bbox="347 770 807 1144"> <thead> <tr> <th>Number of indicative marking points seen in answer</th> <th>Number of marks awarded for indicative marking points</th> </tr> </thead> <tbody> <tr> <td>6</td> <td>4</td> </tr> <tr> <td>5 - 4</td> <td>3</td> </tr> <tr> <td>3 - 2</td> <td>2</td> </tr> <tr> <td>1</td> <td>1</td> </tr> <tr> <td>0</td> <td>0</td> </tr> </tbody> </table>	Number of indicative marking points seen in answer	Number of marks awarded for indicative marking points	6	4	5 - 4	3	3 - 2	2	1	1	0	0	<p>Guidance on how the mark scheme should be applied:</p> <p>The mark for indicative content should be added to the mark for lines of reasoning. For example an answer with five indicative marking points which is partially structured with some linkages and lines of reasoning scores 4 marks (3 marks for indicative content and 1 mark for partial structure and some linkages and lines of reasoning).</p> <p>If there are no linkages between points, the same five indicative marking points would yield an overall score of 3 marks (3 marks for indicative content and no marks for linkages).</p>	
Number of indicative marking points seen in answer	Number of marks awarded for indicative marking points														
6	4														
5 - 4	3														
3 - 2	2														
1	1														
0	0														

Question Number	Acceptable Answer	Additional Guidance	Mark								
* (continued)	<p>The following table shows how the marks should be awarded for structure and lines of reasoning.</p> <table border="1" data-bbox="360 1368 1046 1832"> <thead> <tr> <th></th> <th>Number of marks awarded for structure of answer and sustained line of reasoning</th> </tr> </thead> <tbody> <tr> <td>Answer shows a coherent and logical structure with linkages and fully sustained lines of reasoning demonstrated throughout</td> <td>2</td> </tr> <tr> <td>Answer is partially structured with some linkages and lines of reasoning</td> <td>1</td> </tr> <tr> <td>Answer has no linkages between points and is unstructured</td> <td>0</td> </tr> </tbody> </table>		Number of marks awarded for structure of answer and sustained line of reasoning	Answer shows a coherent and logical structure with linkages and fully sustained lines of reasoning demonstrated throughout	2	Answer is partially structured with some linkages and lines of reasoning	1	Answer has no linkages between points and is unstructured	0		
	Number of marks awarded for structure of answer and sustained line of reasoning										
Answer shows a coherent and logical structure with linkages and fully sustained lines of reasoning demonstrated throughout	2										
Answer is partially structured with some linkages and lines of reasoning	1										
Answer has no linkages between points and is unstructured	0										

Question Number	Acceptable Answer	Additional Guidance	Mark
* (continued)	<p>Indicative content</p> <ul style="list-style-type: none"> Analyses and interprets the text to conclude that diffraction occurs when light is reflected from the CD surface Each ring on the CD acts as a diffraction centre scattering light in all directions Interference occurs (superposition of light from the multiple light sources) In directions in which there is a phase difference equal to an even multiple of π rad constructive interference (reinforcement) occurs OR in directions in which there is a path difference equal to a whole number of wavelengths constructive interference (reinforcement) occurs White light is a range (mixture) of wavelengths Hence each wavelength of light reinforces in a different direction which explains why a spectrum is seen 		6

Q18.

Question Number	Acceptable Answer	Additional Guidance	Mark
	<ul style="list-style-type: none"> Coherent waves have a constant phase relationship (1) Coherent waves have the same frequency (1) However, for each frequency present the (two) reflected waves are coherent (1) Hence with a non-monochromatic source, a set of dark rings for each frequency would be produced (1) 	<p>MP2-4: accept wavelength for frequency</p> <p>MP4: hence with a white light source you would see a set of coloured rings</p>	4

Q19.

Question Number	Acceptable answers	Additional guidance	Mark
(a)	<p>An explanation that makes reference to the following:</p> <ul style="list-style-type: none"> The light is diffracted (1) (because) each point on wavefront acts as a source of secondary waves Or wavelets emitted (from points on the wavefront) (1) 	Marks may be shown on a clearly labelled diagram	2

Question Number	Acceptable answers	Additional guidance	Mark
(b)	<p>An explanation that makes reference to the following:</p> <ul style="list-style-type: none"> Path lengths (to centre of shadow from edge of ball) are equal (1) Or path difference (at spot) is zero Will arrive in phase Or phase difference is zero (1) (Bright spot is position of) <u>constructive interference/superposition</u> (1) 		3

Q20.

Question Number	Acceptable Answers	Additional Guidance	Mark
	<ul style="list-style-type: none"> The wave spreads out (after passing through a gap) (1) Each point on the wave acts as a source of (secondary) wavelets (1) That interfere/superpose (1) 		3

Q21.

Question Number	Answer	Additional Guidance	Mark
	<ul style="list-style-type: none"> • use of $n_1 \sin \theta_1 = n_2 \sin \theta_2$ and $n = \frac{c}{v}$ (1) • $v = 2.3 \times 10^8 \text{ m s}^{-1}$ (1) • conclusion comparing their answer to $3.0 \times 10^8 \text{ m s}^{-1}$ (1) 	<p>Accept use of $n_1 \sin \theta_1 = n_2 \sin \theta_2$ to establish that $n(\text{water}) > 1$ with conclusion referring to $n = \frac{c}{v}$</p> <p><u>Example of calculation</u> $n(\text{water}) = \frac{\sin 35}{\sin 26} = 1.3$ $v(\text{water}) = \frac{3.0 \times 10^8 \text{ m s}^{-1}}{1.3} = 2.3 \times 10^8 \text{ m s}^{-1}$</p>	3

Q22.

Question Number	Answer	Additional Guidance	Mark
	<ul style="list-style-type: none"> • Experimental evidence became available (eg speed of light in water) or wave model could be used to explain other properties of light or Huygens' construction could be used to explain interference/diffraction (1) • further support for wave theory by other scientists (eg Thomas Young) or (younger) scientists were willing to accept new ideas (1) 	<p>MP1 the idea of evidence MP2 the idea of further support</p>	2

Q23.

Question Number	Acceptable Answers	Additional guidance	Mark
	<ul style="list-style-type: none"> • Waves (from gaps) superpose/interference (1) • Constructive (interference) when waves are in phase Or path difference is $n\lambda$ (1) • Destructive (interference) when waves are in antiphase Or path difference is $(n + \frac{1}{2})\lambda$ (1) • Links constructive interference to maximum intensity Or links destructive interference with minimum/zero intensity (1) 	<p>Not superimpose MP3 Do not accept out of phase</p>	4

Q24.

Question Number	Answer	Additional guidance	Mark
	D		(1)

Q25.

Question Number	Answer	Additional guidance	Mark
	B	$(\lambda / 2)$	(1)

Q26.

Question Number	Answers	Additional Guidance	Mark
	D	have the same frequency	(1)

Q27.

Question Number	Acceptable Answers	Additional guidance	Mark
	<ul style="list-style-type: none"> Line/surface joining points on a wave that are in phase 	(1)	1

Q28.

Question Number	Acceptable answers	Additional guidance	Mark
	<p>The only correct answer is C because the maximum order reached corresponds to the highest integer value less than or equal to line spacing divided by wavelength, which is 4, and there are that many orders either side of the maximum plus a central order</p> <p>A is not correct because the maximum order reached corresponds to the highest integer value less than or equal to line spacing divided by wavelength, which is 4, and there are that many orders either side of the maximum plus a central order, but this answer only gives the number of orders on one side of the central order</p> <p>B is not correct because the maximum order reached corresponds to the highest integer value less than or equal to line spacing divided by wavelength, which is 4, but this order rounds 4.7 to 5 and doesn't consider the central maximum or that there are orders on either side</p> <p>D is not correct because the maximum order reached corresponds to the highest integer value less than or equal to line spacing divided by wavelength, which is 4, but this order rounds 4.7 to 5 and then adds the orders on the other side and the central maximum</p>		1

Q29.

Question Number	Acceptable Answers	Additional guidance	Mark
	<ul style="list-style-type: none"> • emits a very small range of frequencies/wavelengths (1) • so smaller variation at each diffraction angle (1) • producing a clearer/sharper interference pattern (1) 		3

Q30.

Question Number	Acceptable Answer	Additional Guidance	Mark
	<ul style="list-style-type: none"> • No of divisions read from oscilloscope trace (1) • Use of time base setting (1) • Use of $f = 1/T$ (1) • Use of $v = f\lambda$ (1) • $v = 340 \text{ m s}^{-1}$ (1) 	<p>MP1: Must be for a recognised part of wave</p> <p><u>Example of calculation</u></p> $T = 3 \times 0.20 \times 10^{-3} \text{ s} = 6.0 \times 10^{-4} \text{ s}$ $f = \frac{1}{6.0 \times 10^{-4} \text{ s}} = 1.67 \times 10^3 \text{ Hz}$ $v = 1.67 \times 10^3 \text{ s}^{-1} \times 0.205 \text{ m} = 342 \text{ m s}^{-1}$	5

Q31.

Question Number	Acceptable answers	Additional guidance	Mark
	<ul style="list-style-type: none"> • Wave and reflection will meet (1) • Superposition / interference occurs (1) • Where in antiphase, destructive interference (1) • Zero/minimum amplitude at nodes – so mice won't hear (1) <p>Either</p> <ul style="list-style-type: none"> • But node separation = $\frac{1}{2}$ wavelength = (about) 7 mm (1) • Too small a space for a mouse to avoid the ultrasound, so suggestion not correct (1) <p>Or (MP5 and 6)</p> <ul style="list-style-type: none"> • Wall absorbs some ultrasound so reflected wave has smaller amplitude than incident wave (1) • Incomplete cancellation, some ultrasound even at nodes, so suggestion (probably) incorrect (1) <p>Or (MP5 and 6)</p> <ul style="list-style-type: none"> • Waves also arrive from other walls/floor/ceiling/multiple reflection (1) • Complete cancellation unlikely so suggestion (probably) incorrect (1) <p>Or (MP5 and 6)</p> <ul style="list-style-type: none"> • A standing wave will only be formed if the length of the room is a whole number of half wavelengths (1) • Otherwise there will be no nodes so no silent spots where the mouse won't hear (1) 	<p><u>Example of calculation</u> $\lambda/2 = 0.013 \text{ m} / 2$ $= 0.0065 \text{ m}$</p>	6

Q32.

Question Number	Acceptable Answers	Additional guidance	Mark
	<ul style="list-style-type: none"> • The resolution would be the same but the distance measured is greater <p>Or</p> <ul style="list-style-type: none"> • The uncertainty would be the same but is divided by a greater length (1) 		1

Q33.

Question Number	Acceptable Answers	Additional Guidance	Mark
	<p>An explanation that makes reference to:</p> <ul style="list-style-type: none"> coherent means there is a constant phase relationship (1) for some parts of the beam the phase difference could be 180°/in antiphase (1) causing destructive interference and therefore zero amplitude (1) 		3

Q34.

Question Number	Answer	Mark
	C $\frac{\pi}{3}$	1
	<p>Incorrect Answers:</p> <p>A – incorrect</p> <p>B – incorrect</p> <p>D – incorrect</p>	

Q35.

Question number	Acceptable answers	Additional guidance	Mark												
*	<p>This question assesses a student's ability to show a coherent and logically structured answer with linkages and fully-sustained reasoning.</p> <p>Marks are awarded for indicative content and for how the answer is structured and shows lines of reasoning.</p> <p>The following table shows how the marks should be awarded for indicative content.</p> <table border="1"> <thead> <tr> <th>Number of indicative marking points seen in answer</th> <th>Number of marks awarded for indicative marking points</th> </tr> </thead> <tbody> <tr> <td>6</td> <td>4</td> </tr> <tr> <td>5-4</td> <td>3</td> </tr> <tr> <td>3-2</td> <td>2</td> </tr> <tr> <td>1</td> <td>1</td> </tr> <tr> <td>0</td> <td>0</td> </tr> </tbody> </table>	Number of indicative marking points seen in answer	Number of marks awarded for indicative marking points	6	4	5-4	3	3-2	2	1	1	0	0	<p>Guidance on how the mark scheme should be applied:</p> <p>The mark for indicative content should be added to the mark for lines of reasoning. For example, an answer with five indicative marking points which is partially structured with some linkages and lines of reasoning scores 4 marks (3 marks for indicative content and 1 mark for partial structure and some linkages and lines of reasoning).</p> <p>If there are no linkages between points, the same five indicative marking points would yield an overall score of 3 marks (3 marks for indicative content and no marks for linkages).</p>	
Number of indicative marking points seen in answer	Number of marks awarded for indicative marking points														
6	4														
5-4	3														
3-2	2														
1	1														
0	0														

Question number	Additional guidance	Mark								
* (continued)	<p>The following table shows how the marks should be awarded for structure and lines of reasoning.</p> <table border="1"> <thead> <tr> <th></th> <th>Number of marks awarded for structure of answer and sustained line of reasoning</th> </tr> </thead> <tbody> <tr> <td>Answer shows a coherent and logical structure with linkages and fully sustained lines of reasoning demonstrated throughout</td> <td>2</td> </tr> <tr> <td>Answer is partially structured with some linkages and lines of reasoning</td> <td>1</td> </tr> <tr> <td>Answer has no linkages between points and is unstructured</td> <td>0</td> </tr> </tbody> </table>		Number of marks awarded for structure of answer and sustained line of reasoning	Answer shows a coherent and logical structure with linkages and fully sustained lines of reasoning demonstrated throughout	2	Answer is partially structured with some linkages and lines of reasoning	1	Answer has no linkages between points and is unstructured	0	
	Number of marks awarded for structure of answer and sustained line of reasoning									
Answer shows a coherent and logical structure with linkages and fully sustained lines of reasoning demonstrated throughout	2									
Answer is partially structured with some linkages and lines of reasoning	1									
Answer has no linkages between points and is unstructured	0									

Question Number	Acceptable answers	Additional guidance	Mark
* (continued)	<p>Indicative content</p> <ul style="list-style-type: none"> • Sound waves incident upon surfaces within the concert hall will be reflected. • Some frequencies will arrive from different directions with a phase difference of (any odd multiple of) π radians (1) OR path difference is odd number of half wavelengths • Destructive superposition/interference will occur, causing the waves with those frequencies to be quieter than others. • Other frequencies arrive with a phase difference of zero or (any multiple of) 2π radians (1) OR a whole number of wavelengths • Constructive superposition/interference will occur, causing waves with those frequencies to be louder than others. • Problem arises due to reflections from walls, so use absorbing material on surfaces to reduce reflections. 		6

Question Number	Acceptable answers	Additional guidance	Mark
* (continued)	<p>Alternative approach based on standing waves:</p> <ul style="list-style-type: none"> • Sound waves incident upon surfaces within the concert hall will be reflected. • Reflections from walls set up standing waves (in room) • Nodes and antinodes are formed for certain frequencies of sound • Nodes are areas of zero/low amplitude so the frequencies of those sound waves will be quieter than others • Antinodes are areas of maximum amplitude so the frequencies of these sound waves will be louder than others • Problem arises due to reflections from walls, so use absorbing material on surfaces to reduce reflections 		

Q36.

Question Number	Acceptable answers	Additional guidance	Mark
	<ul style="list-style-type: none"> Two or more waves meet (1) The (resultant) displacement (at a point) is the sum of the individual displacements from the individual waves (1) 	Do not accept sum of amplitudes	2

Q37.

Question Number	Acceptable Answer	Additional Guidance	Mark
	<p>An explanation that makes reference to the following points:</p> <ul style="list-style-type: none"> Maxima on one side move closer to the central maximum (1) Maxima on the other side move further away from the central maximum (1) Intensity of maxima would be different on each side of central maximum (1) 	Allow 1 mark for spacing of maxima on screen will change	3

Q38.

Question Number	Acceptable Answer	Additional Guidance	Mark
	<p>An explanation that makes reference to the following points:</p> <ul style="list-style-type: none"> Measure the distance between the two 1st/2nd order maxima (1) Or measure the distance from the 2nd order to the central maximum (1) Or increase the distance from the grating to the screen This increases the distance measured on the screen (and reduce the % uncertainty) <p>MP2 dependent upon MP1</p>		2

Q39.

Question Number	Acceptable answers	Additional guidance	Mark
	<ul style="list-style-type: none"> Wave model (1) <p>Any two</p> <ul style="list-style-type: none"> (Demonstration) provided experimental evidence (in support of wave model) (1) (Demonstration) supported previous evidence (1) (This demonstration was) reproducible (1) Or (This demonstration) could be repeated by others (1) 		3

Q40.

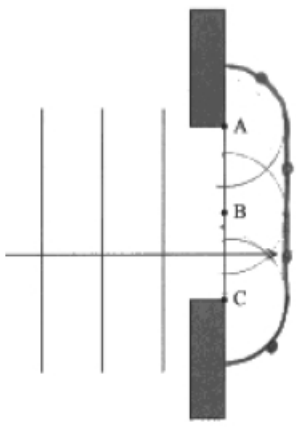
Question Number	Acceptable Answers	Additional guidance	Mark
(i)	<ul style="list-style-type: none"> A line/surface/plane along which all the points are in phase (1) 		1
(ii)	<ul style="list-style-type: none"> A wavelet drawn centred on any point on the line AC (1) Minimum of three wavelets drawn (extending to right hand side) with radii equal (by eye) to distance between incoming wavefronts (1) New wavefront drawn with correct shape and position along leading edge of wavelets (1) 	Accept curved line, arc, circle or semicircle for wavelets 	3

Q41.

Question Number	Acceptable Answers	Additional guidance	Mark
	<ul style="list-style-type: none"> Use of $\tan \theta = \frac{x}{D}$ (1) Use of $d = 1/300$ (1) Use of $n\lambda = d \sin \theta$ (1) $\lambda = 530$ (nm) with conclusion green (1) 	<p>Example of Calculation</p> $d = 1/(300 \times 10^3 \text{m}^{-1}) = 3.33 \times 10^{-6} \text{ m}$ $\theta = \tan^{-1} \frac{1.35}{4.0} = 18.65^\circ$ $\lambda = \frac{3.33 \times 10^{-6} \text{ m} \times \sin 18.65^\circ}{2} = 5.32 \times 10^{-7} \text{ m} = 532 \text{ nm}$ <p>Green</p>	4