

Q1.

8 (a) State three characteristics of an ideal operational amplifier (op-amp).

1.
2.
3. [3]

(b) An amplifier circuit for a microphone is shown in Fig. 8.1.

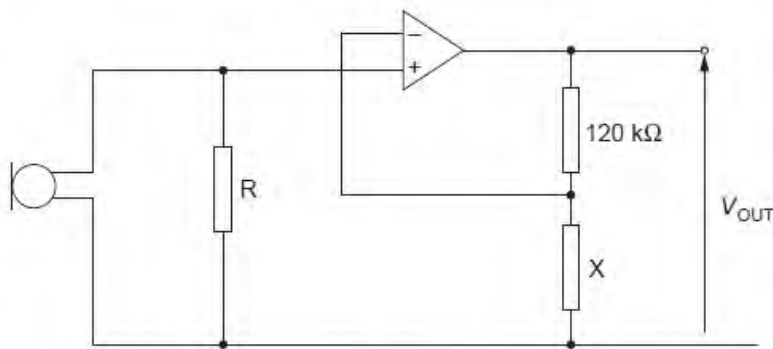

Fig. 8.1

(i) Name the type of feedback used with this op-amp.

..... [1]

(ii) The output potential difference V_{OUT} is 5.8V for a potential difference across the resistor R of 69 mV. Calculate

1. the gain of the amplifier circuit,

gain = [1]

2. the resistance of resistor X.

resistance = Ω [2]

(iii) State one effect on the amplifier output of reducing the resistance of resistor X.

.....
..... [1]

Q2.

9 A block diagram for an electronic sensor is shown in Fig. 9.1.



Fig. 9.1

(a) Complete Fig. 9.1 by labelling the remaining boxes. [2]

(b) A device is to be built that will emit a red light when its input is at +2 V. When the input is at -2V, the light emitted is to be green.

(i) On Fig. 9.2, draw a circuit diagram of the device.

input
either + 2V  —————
or - 2V



Fig. 9.2

[2]

(ii) Explain briefly the action of this device.

.....

.....

[1]

Q3.

10 (a) By reference to an amplifier, explain what is meant by *negative feedback*.

.....

 [2]

(b) An amplifier circuit incorporating an ideal operational amplifier (op-amp) is shown in Fig. 10.1.

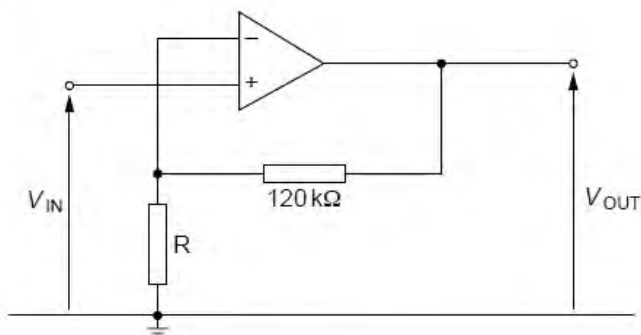

Fig. 10.1

The supply for the op-amp is $\pm 9.0\text{V}$.
 The amplifier circuit is to have a gain of 25.

Calculate the resistance of resistor R.

resistance = Ω [2]

(c) State the value of the output voltage V_{OUT} of the amplifier in (b) for input voltages V_{IN} of

(i) -0.08V ,

$V_{\text{OUT}} = \dots\dots\dots \text{V}$ [1]

(ii) $+0.4\text{V}$.

$V_{\text{OUT}} = \dots\dots\dots \text{V}$ [1]

Q4.

- 9 The circuit diagram of Fig. 9.1 is an amplifier circuit incorporating an operational amplifier (op-amp).

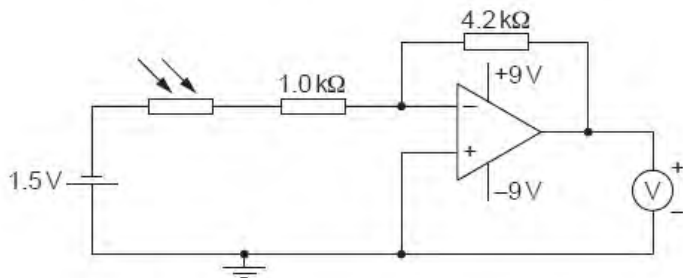

Fig. 9.1

- (a) (i) On Fig. 9.1, mark, with the letter X, the virtual earth. [1]

- (ii) Explain what is meant by a *virtual earth*.

.....

.....

.....

..... [3]

- (b) In bright sunlight, the light-dependent resistor (LDR) has resistance $200\ \Omega$.

- (i) Calculate, for the LDR in bright sunlight, the voltmeter reading.

reading = V [3]

- (ii) The sunlight incident on the LDR becomes less bright.
State and explain the effect on the voltmeter reading of this decrease in brightness.

F
Exar
L

.....

.....

.....

..... [3]

Q5.

- 9 (a) Negative feedback may be used in amplifier circuits. State

- (i) what is meant by *negative feedback*,

.....

.....

..... [2]

- (ii) two effects of negative feedback on an amplifier incorporating an operational amplifier (op-amp).

1.

.....

2.

..... [2]

(b) Fig. 9.1 is a circuit for an amplifier that is used with a microphone.

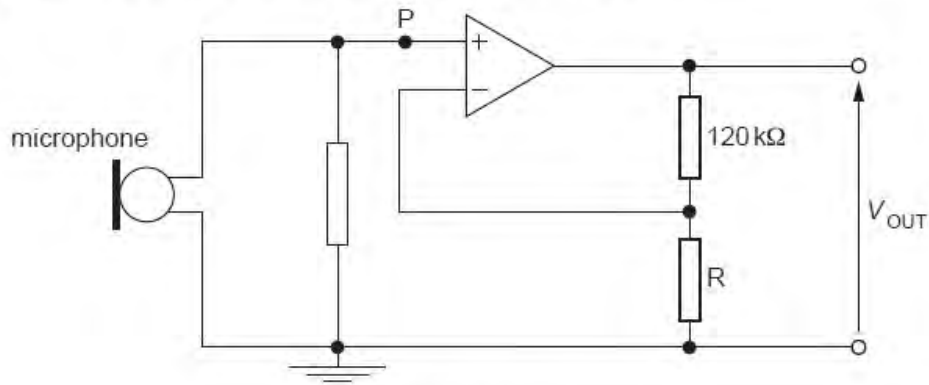

Fig. 9.1

The output potential difference V_{OUT} is 4.4V when the potential at point P is 62mV.

Determine

(i) the gain of the amplifier,

gain = [1]

(ii) the resistance of the resistor R.

resistance = Ω [2]

(c) The maximum potential produced by the microphone at point P on Fig. 9.1 is 95 mV.
The power supply for the operational amplifier may be either ± 5 V or ± 9 V.

State which power supply should be used. Justify your answer quantitatively.

.....
.....
.....
..... [3]

Q6.

10 (a) State the name of an electrical sensing device that will respond to changes in

(i) length,

..... [1]

(ii) pressure.

..... [1]

(b) A relay is sometimes used as the output of a sensing circuit.

The output of a particular sensing circuit is either +2V or -2V.

On Fig. 10.1, draw symbols for a relay and any other necessary component so that the external circuit is switched on only when the output from the sensing circuit is +2V.

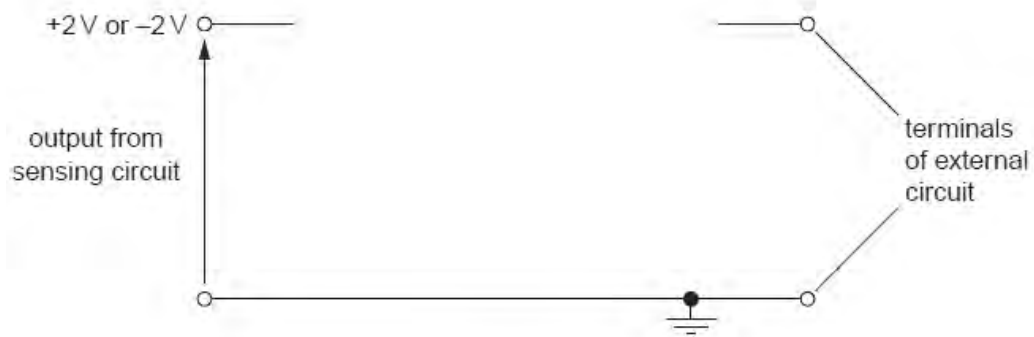

Fig. 10.1

[4]

Q7.

- 9 (a) An operational amplifier (op-amp) may be used as a comparator. State the function of a comparator.

.....

 [2]

- (b) The variation with temperature θ of the resistance R of a thermistor is shown in Fig. 9.1.

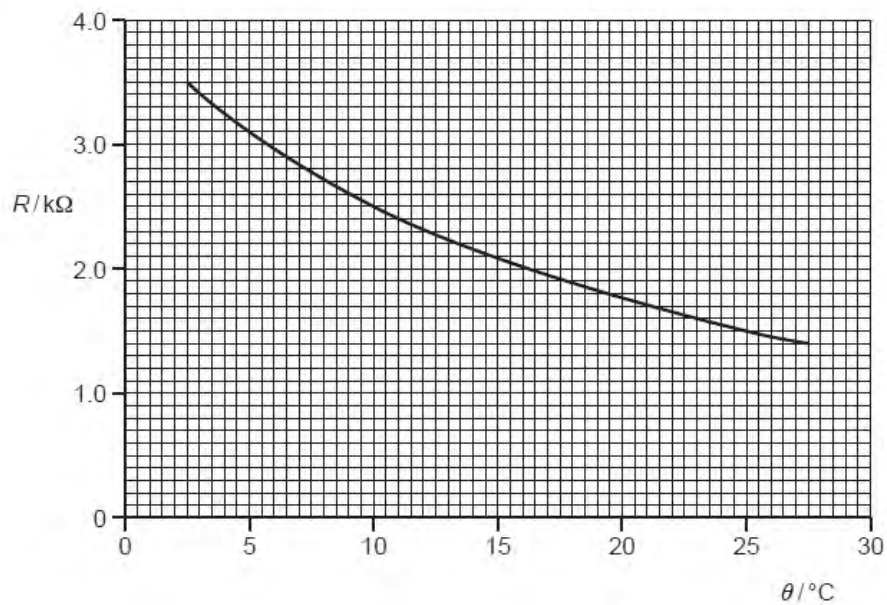

The thermistor is connected into the circuit of Fig. 9.2.

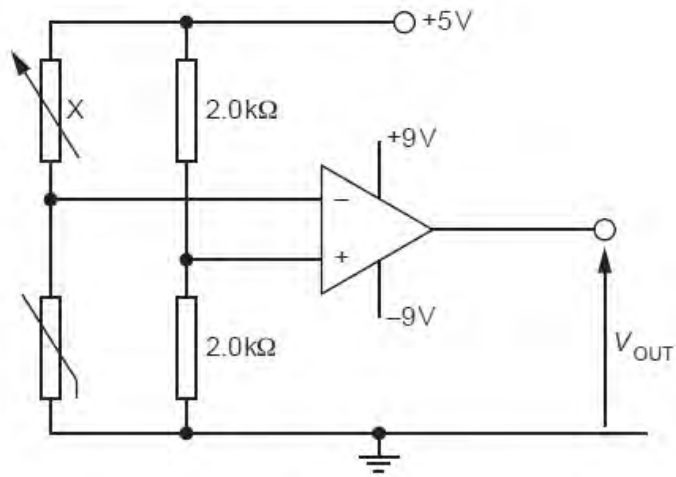

Fig. 9.2

The op-amp may be considered to be ideal.

- (i) The temperature of the thermistor is 10°C . Determine the resistance of the variable resistor X such that the output potential V_{OUT} is zero.

resistance = Ω [2]

- (ii) The resistance of the resistor X is now held constant at the value calculated in (i). Describe the change in the output potential V_{OUT} as the temperature of the thermistor is changed from 5°C to 20°C .

.....

.....

.....

.....

.....

..... [4]

Q8.

- 9 (a) Describe the structure of a metal wire strain gauge. You may draw a diagram if you wish.

.....

.....

.....

.....

..... [3]

- (b) A strain gauge S is connected into the circuit of Fig. 9.1.

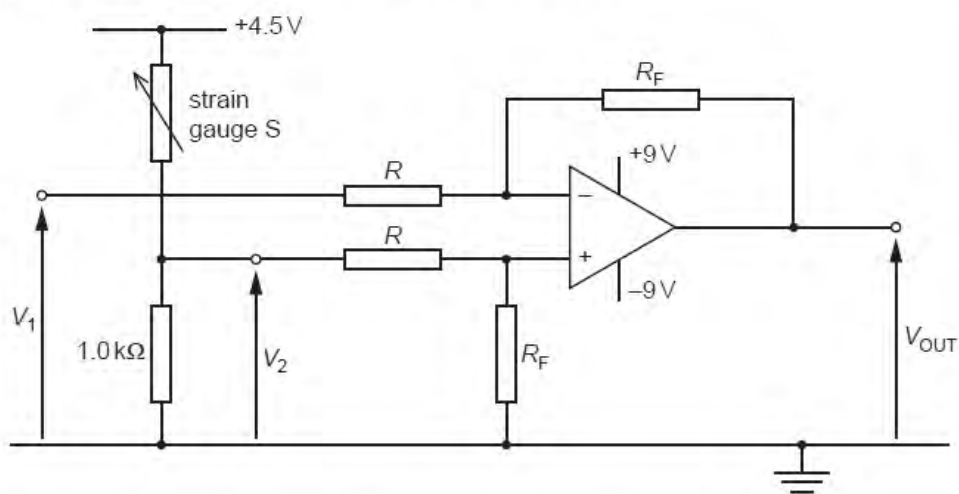

Fig. 9.1

The operational amplifier (op-amp) is ideal.

The output potential V_{OUT} of the circuit is given by the expression

$$V_{OUT} = \frac{R_F}{R} \times (V_2 - V_1).$$

- (i) State the name given to the ratio $\frac{R_F}{R}$.

..... [1]

- (ii) The strain gauge S has resistance 125Ω when not under strain.
Calculate the magnitude of V_1 such that, when the strain gauge S is not strained, the output V_{OUT} is zero.

For
Examin
Use

$$V_1 = \dots\dots\dots \text{ V [3]}$$

- (iii) In a particular test, the resistance of S increases to 128Ω . V_1 is unchanged.
The ratio $\frac{R_F}{R}$ is 12.
Calculate the magnitude of V_{OUT} .

$$V_{OUT} = \dots\dots\dots \text{ V [2]}$$

Q9.

- 10 A student designs an electronic sensor that is to be used to switch on a lamp when the light intensity is low. Part of the circuit is shown in Fig. 10.1.

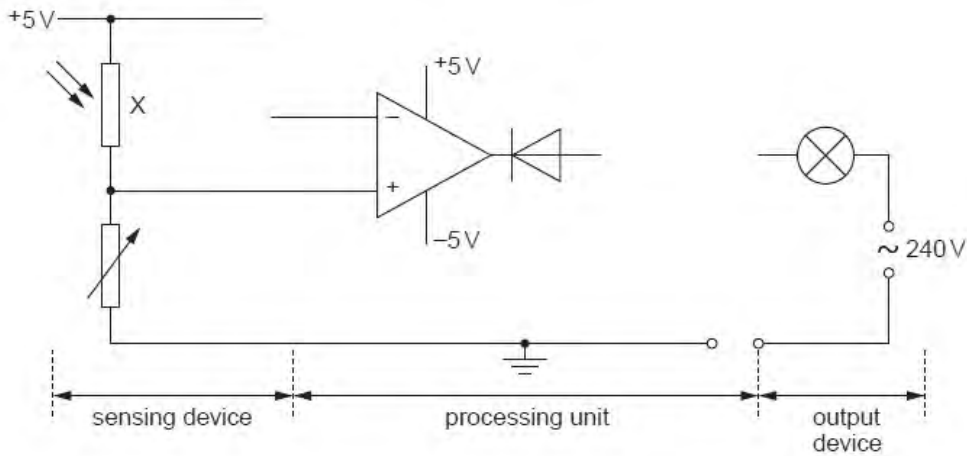

Fig. 10.1

- (a) State the name of the component labelled X on Fig. 10.1.

..... [1]

- (b) On Fig. 10.1, draw the symbols for

- (i) two resistors to complete the circuit for the sensing device, [2]
 (ii) a relay to complete the circuit for the processing unit. [2]

- (c) (i) State the purpose of the relay.

..... [1]

- (ii) Suggest why the diode is connected to the output of the operational amplifier (op-amp) in the direction shown.

..... [2]

Q10.

9 An operational amplifier (op-amp) may be used as part of the processing unit in an electronic sensor.

(a) State four properties of an ideal operational amplifier.

1.
2.
3.
4.

[4]

(b) A comparator circuit incorporating an ideal op-amp is shown in Fig. 9.1.

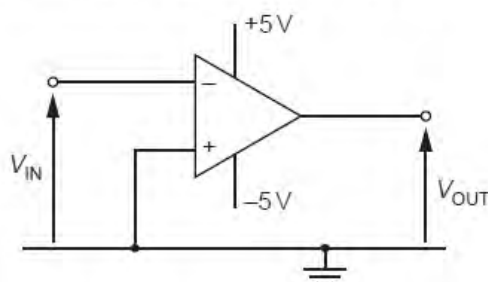

Fig. 9.1

The variation with time t of the input potential V_{IN} is shown in Fig. 9.2.

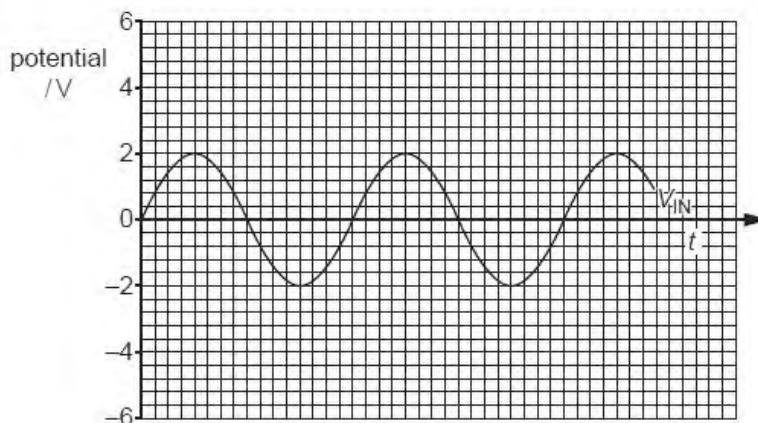

Fig. 9.2

On the axes of Fig. 9.2, draw a graph to show the variation with time t of the output potential V_{OUT} . [3]

- (c) The output potential V_{OUT} is to be displayed using two light-emitting diodes (LEDs). A diode emitting red light is to indicate when V_{OUT} is positive and a diode emitting green light is to be used to indicate when V_{OUT} is negative.

For
Examine
Use

Complete Fig. 9.3 to show the connections of the two LEDs to the output of the op-amp. Label each LED with the colour of light that it emits.

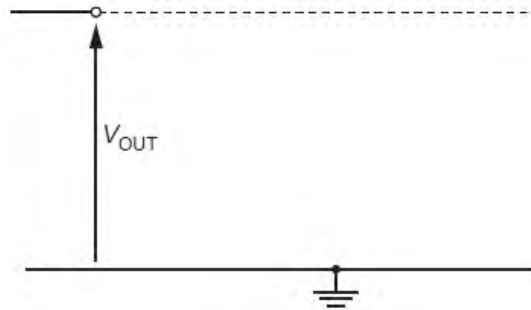

Fig. 9.3

[3]

Q11.

- 9 (a) Suggest electrical sensing devices, one in each case, that may be used to monitor changes in

(i) light intensity,

.....[1]

(ii) the width of a crack in a welded joint,

.....[1]

(iii) the intensity of an ultrasound beam.

.....[1]

- (b) A student designs the circuit of Fig. 9.1 to detect changes in temperature in the range 0°C to 100°C .

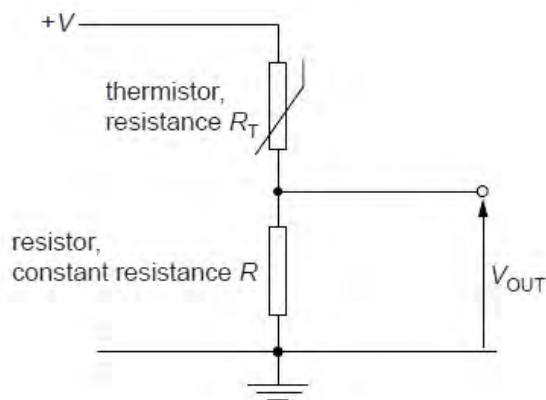

Fig. 9.1

The resistance of the thermistor is R_T and that of the resistor is R .
The student monitors the potential difference V_{OUT} .

State and explain

- (i) whether V_{OUT} increases or decreases as the temperature of the thermistor increases,

.....
.....
.....
..... [3]

- (ii) whether the change in V_{OUT} varies linearly with the change in temperature of the thermistor.

.....
.....
.....
..... [2]

Q12.

- 9 The volume of fuel in the fuel tank of a car is monitored using a sensing device. The device gives a voltage output that is measured using a voltmeter. The variation of voltmeter reading with the volume of fuel in the tank is shown in Fig. 9.1.

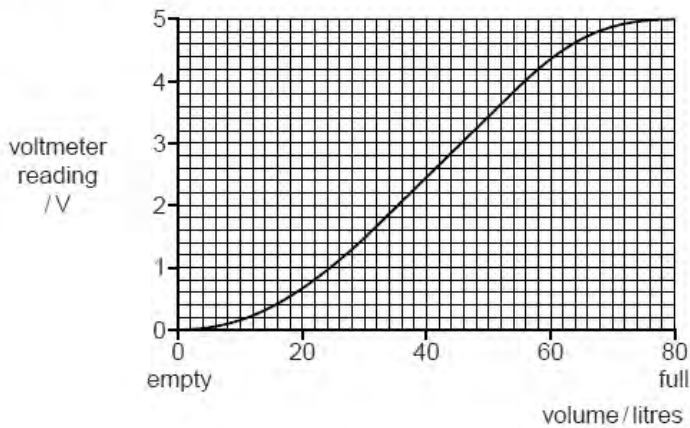

Fig. 9.1

- (a) Use Fig. 9.1 to determine the range of volume over which the volume has a linear relationship to the voltmeter reading.

from litres to litres [1]

- (b) Suggest why, comparing values from Fig. 9.1,

- (i) when the tank is nearly full, the voltmeter readings give the impression that fuel consumption is low,

.....

 [2]

- (ii) when the voltmeter first indicates that the tank is nearly empty, there is more fuel remaining than is expected.

.....

 [2]

Q13.

8 (a) Fig. 8.1 shows a circuit incorporating an ideal operational amplifier (op-amp).

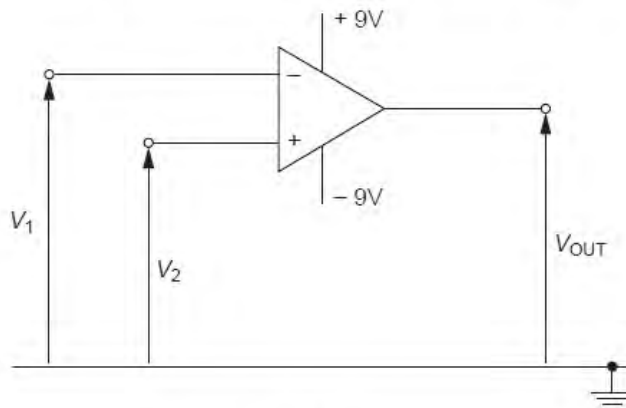

Fig. 8.1

The voltages applied to the inverting and the non-inverting inputs are V_1 and V_2 respectively.

State the value of the output voltage V_{OUT} when

(i) $V_1 > V_2$,

$$V_{OUT} = \dots\dots\dots \text{V}$$

(ii) $V_1 < V_2$.

$$V_{OUT} = \dots\dots\dots \text{V}$$

[1]

(b) The circuit of Fig. 8.2 is used to monitor the input voltage V_{IN} .

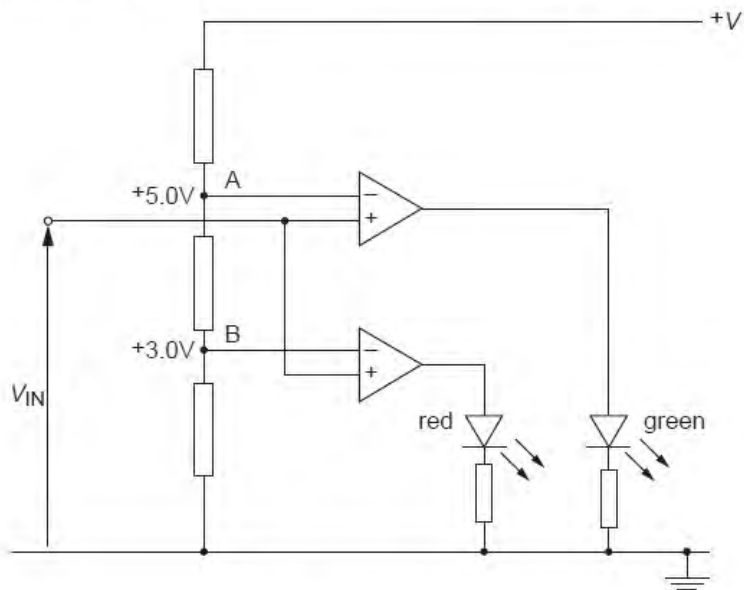

Fig. 8.2

At point A, a potential of 5.0V is maintained. At point B, a potential of 3.0V is maintained.

Complete Fig. 8.3 by indicating with a tick (✓) the light-emitting diodes (LEDs) that are conducting for the input voltages V_{IN} shown. Also, mark with a cross (✗) those LEDs that are not conducting.

| V_{IN} / V | red LED | green LED |
|--------------|---------|-----------|
| +2.0 | | |
| +4.0 | | |
| +6.0 | | |

Fig. 8.3

[3]

(c) The input voltage V_{IN} in (b) is provided by a sensor circuit.

(i) Complete Fig. 8.4 to show a sensor circuit that will provide a voltage output that increases as the temperature of the sensor decreases. Show clearly the output connections from the circuit. [2]

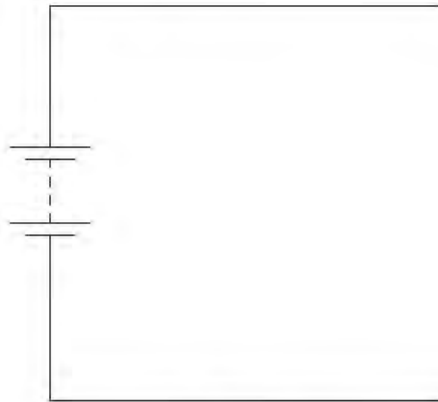

Fig. 8.4

(ii) Explain the operation of the sensor circuit.

.....

.....

.....

.....

.....

.....

.....

[3]

Q14.

- 10 (a) The circuit for an amplifier incorporating an ideal operational amplifier (op-amp) is shown in Fig. 10.1.

For
Examiner's
Use

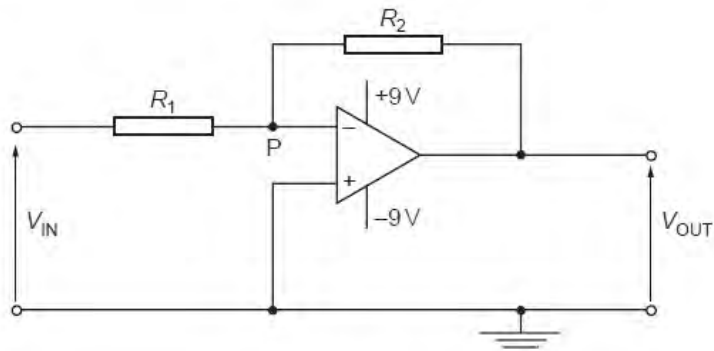

Fig. 10.1

- (i) State
1. the name of this type of amplifier circuit,

.....[1]

2. why the point P is referred to as a *virtual earth*.

.....

.....

.....

..... [3]

(ii) Show that the gain G of this amplifier circuit is given by the expression

$$G = -\frac{R_2}{R_1}.$$

Explain your working.

[4]

- (b) The circuit of Fig. 10.1 is modified by connecting a light-dependent resistor (LDR) as shown in Fig. 10.2.

For
Examiner
Use

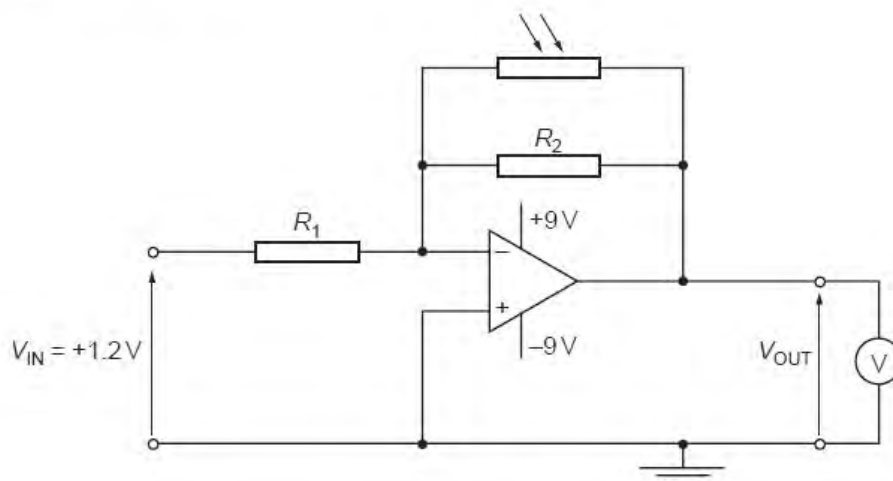

Fig. 10.2

The resistances R_1 and R_2 are $5.0\text{ k}\Omega$ and $50\text{ k}\Omega$ respectively.
The input voltage V_{IN} is $+1.2V$. A high-resistance voltmeter measures the output V_{OUT} .
The circuit is used to monitor low light intensities.

- (i) Determine the voltmeter reading for light intensities such that the LDR has a resistance of

1. $100\text{ k}\Omega$,

reading = V [3]

2. $10\text{ k}\Omega$.

reading = V [2]

- (ii) The light incident on the LDR is provided by a single lamp. Use your answers in (i) to describe and explain qualitatively the variation of the voltmeter reading as the lamp is moved away from the LDR.

Exa

.....

.....

.....

.....

.....

.....

.....

[3]

Q15.

- 9 A metal wire strain gauge is firmly fixed across a crack in a wall, as shown in Fig. 9.1, so that the growth of the crack may be monitored.

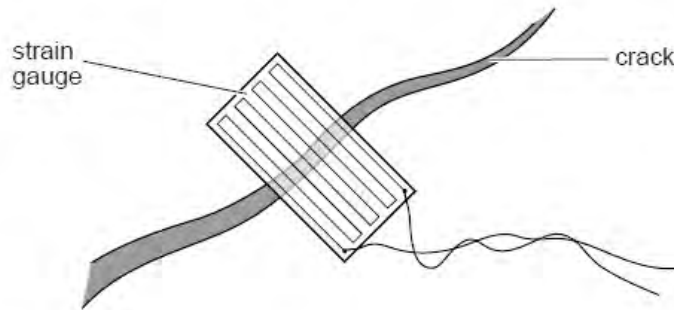

Fig. 9.1

- (a) Explain why, as the crack becomes wider, the resistance of the strain gauge increases.

.....

.....

.....

.....

.....

[3]

- (b) The strain gauge has an initial resistance of 143.0Ω and, after being fixed in position across the crack for several weeks, the resistance is found to be 146.2Ω .

The change in the area of cross-section of the strain gauge wire is negligible.

Calculate the percentage increase in the width of the crack. Explain your working.

increase = % [3]

Q16.

- 10 The circuit of Fig. 10.1 may be used to indicate temperature change.

For
Examine
Use

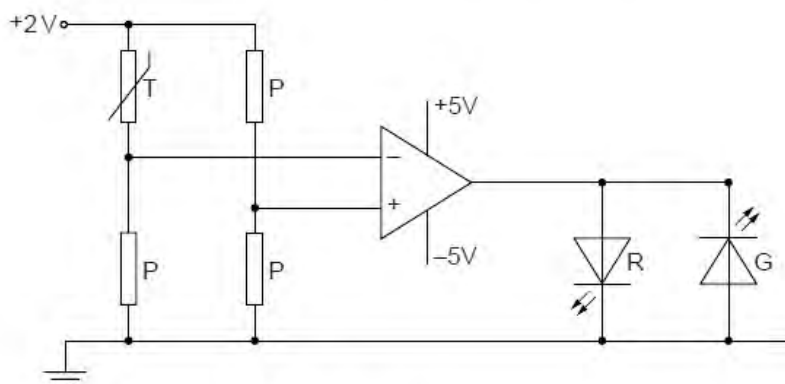

Fig. 10.1

The resistance of the thermistor T at 16°C is 2100Ω and at 18°C , the resistance is 1900Ω . Each resistor P has a resistance of 2000Ω .

Determine the change in the states of the light-emitting diodes R and G as the temperature of the thermistor changes from 16°C to 18°C.

.....
 [4]

Q17.

- 9 An amplifier incorporating an operational amplifier (op-amp) has three inputs A, B and C, as shown in Fig. 9.1.

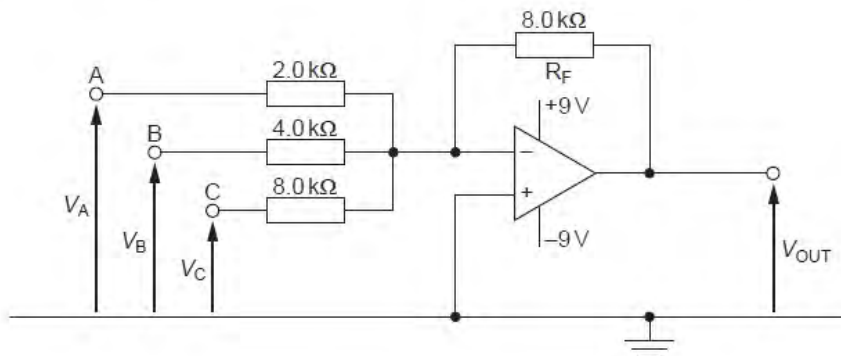

Fig. 9.1

Negative feedback is provided by the resistor R_F of resistance $8.0\text{ k}\Omega$.

For each of the inputs A, B and C, the amplifier may be considered as a single input amplifier. That is, each input is independent of the other two.

When the amplifier is not saturated, the output potential V_{OUT} is given by the expression

$$V_{OUT} = -(4V_A + GV_B + V_C),$$

where V_A , V_B and V_C are the input potentials of the inputs A, B and C respectively and G is a constant.

(a) State two effects of negative feedback on an amplifier.

1.

.....

2.

.....

[2]

(b) In the expression for the output potential V_{OUT} , the constant G is the gain associated with input B. Show that the numerical value of G is 2.

For
Examiner
Use

[1]

(c) The input potentials V_A , V_B and V_C are either zero or 1.0V.

The magnitudes of some output potentials for different combinations of V_A , V_B and V_C are shown in Fig. 9.2.

| V_A/V | V_B/V | V_C/V | V_{OUT}/V |
|---------|---------|---------|-------------|
| 0 | 0 | 1 | 1 |
| 0 | 1 | 0 | |
| 1 | 0 | 0 | 4 |
| 1 | 0 | 1 | 5 |
| 1 | 1 | 0 | |
| 1 | 1 | 1 | |

Fig. 9.2

(i) Complete Fig. 9.2 for the three remaining values of V_{OUT} . [1]

(ii) Suggest a use for this circuit.

..... [1]

Q18.

9 An amplifier circuit incorporating an operational amplifier (op-amp) is shown in Fig. 9.1.

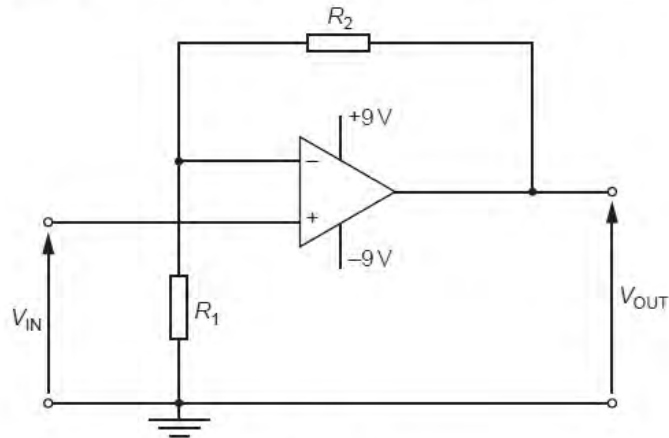

Fig. 9.1

(a) State

(i) the name of this type of amplifier circuit,

.....[1]

(ii) the gain G in terms of resistances R_1 and R_2 .

.....[1]

- (b) The value of R_1 is $820\ \Omega$. The resistor of resistance R_2 is replaced with a light-dependent resistor (LDR).
The input potential difference V_{IN} is 15mV .
Calculate the output potential difference V_{OUT} for the LDR having a resistance of

For
Examiner
Use

- (i) $100\ \Omega$ (the LDR is in sunlight),

$$V_{OUT} = \dots\dots\dots \text{ V [2]}$$

- (ii) $1.0\text{M}\Omega$ (the LDR is in darkness).

$$V_{OUT} = \dots\dots\dots \text{ V [1]}$$

Q19.

10 (a) State three properties of an ideal operational amplifier (op-amp).

1.
2.
3.

[3]

For
Examiner's
Use

(b) A circuit incorporating an ideal op-amp is to be used to indicate whether a door is open or closed. Resistors, each of resistance R , are connected to the inputs of the op-amp, as shown in Fig. 10.1.

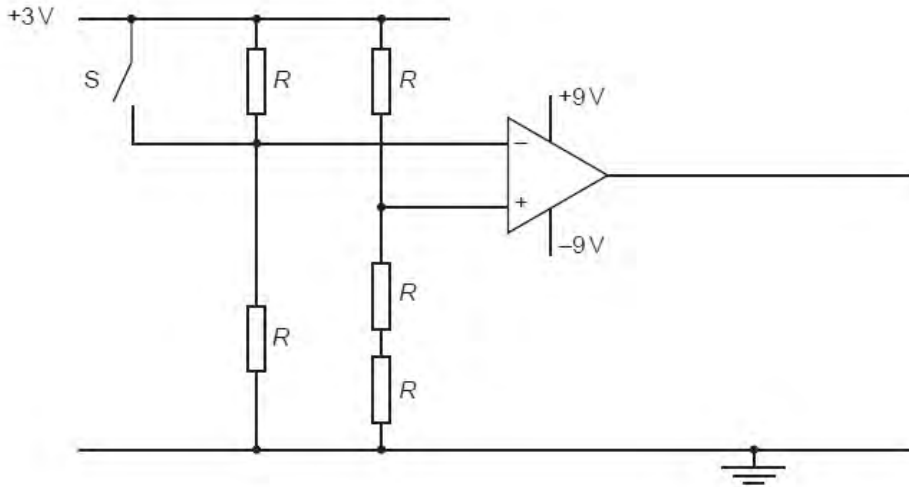

The switch S is attached to the door so that, when the door is open, the switch is open. The switch closes when the door is closed.

(i) Explain why the polarity of the output of the op-amp changes when the switch closes.

-
-
-
-
-

[3]

For
Examiner's
Use

(ii) A red light-emitting diode (LED) is to be used to indicate when the door is open. A green LED is to indicate when the door is closed.

On Fig. 10.1,

1. draw symbols for the LEDs to show how they are connected to the output of the op-amp, [1]
2. identify the green LED with the letter G. [1]

Q20.

- 9 (a) State two effects of negative feedback on the gain of an amplifier incorporating an operational amplifier (op-amp).

1.

 2.

[2]

- (b) An incomplete circuit diagram of a non-inverting amplifier using an ideal op-amp is shown in Fig. 9.1.

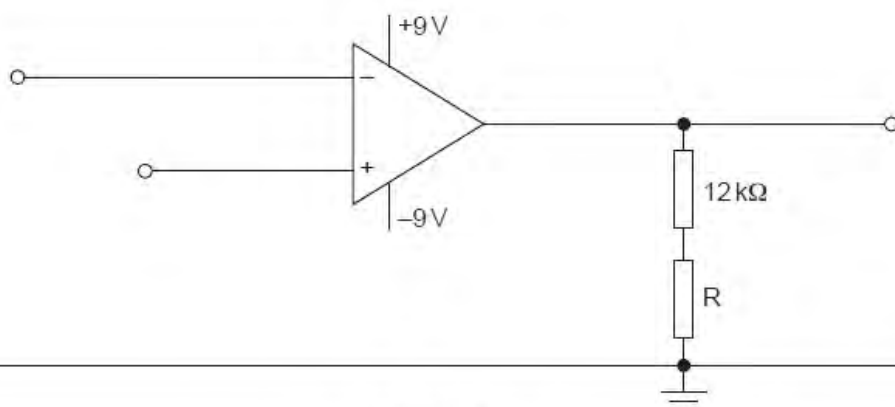

Fig. 9.1

- (i) Complete the circuit diagram of Fig. 9.1. Label the input and the output. [2]

- (ii) Calculate the resistance of resistor R so that the non-inverting amplifier has a voltage gain of 15.

resistance = Ω [2]

- (c) On Fig. 9.2, draw a graph to show the variation with input potential V_{IN} of the output potential V_{OUT} .
You should consider input potentials in the range 0 to +1.0V.

Exe

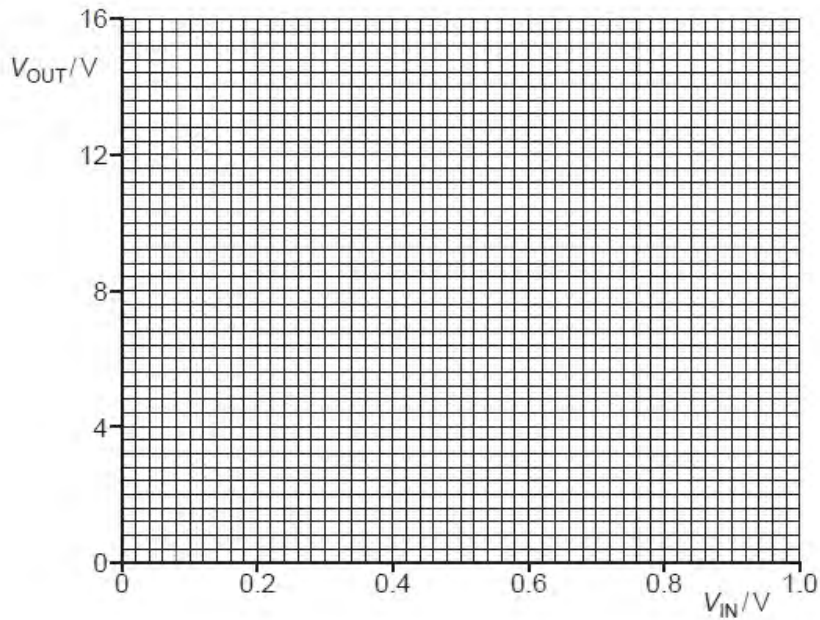

Fig. 9.2

[2]

- (d) The output of the amplifier circuit of Fig. 9.1 may be connected to a relay.
State and explain one purpose of a relay.

.....
.....
..... [2]

Q21.

- 9 (a) The resistance of a light-dependent resistor (LDR) is approximately $500\ \Omega$ in daylight. Suggest an approximate value for the resistance of the LDR in darkness.

resistance = Ω [1]

- (b) An electronic light-meter is used to warn when light intensity becomes low. A light-dependent resistor is connected into the circuit of Fig. 9.1.

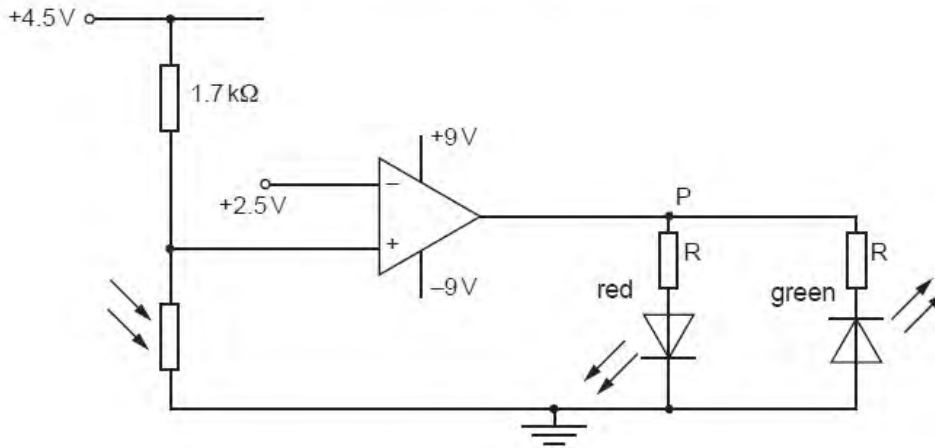

Fig. 9.1

The operational amplifier (op-amp) is ideal.

The resistors R are to ensure that the light-emitting diodes (LEDs) do not over-heat.

- (i) On Fig. 9.1, mark the polarity of the point P for the red LED to be emitting light. [1]
- (ii) The LDR is in daylight and has a resistance of $500\ \Omega$. State and explain which diode, red or green, will be emitting light.

.....

 [3]

- (iii) The intensity of the light decreases and the LDR is in darkness. State and explain the effect on the LEDs of this change in intensity.

.....

 [2]

Q22.

9 An operational amplifier (op-amp) may be used as part of the processing unit in an electronic sensor.

(a) State three properties of an ideal op-amp.

1.
2.
3.

[3]

(b) A comparator circuit incorporating an ideal op-amp is shown in Fig. 9.1.

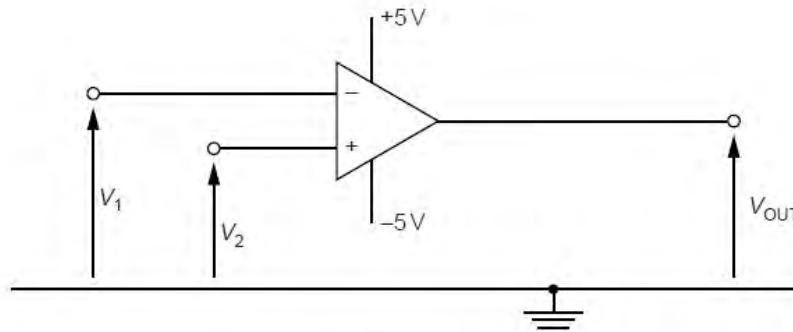

Fig. 9.1

(i) In one application of the comparator, V_2 is kept constant at +1.5V. The variation with time t of the potential V_1 is shown in Fig. 9.2. The potential V_2 is also shown.

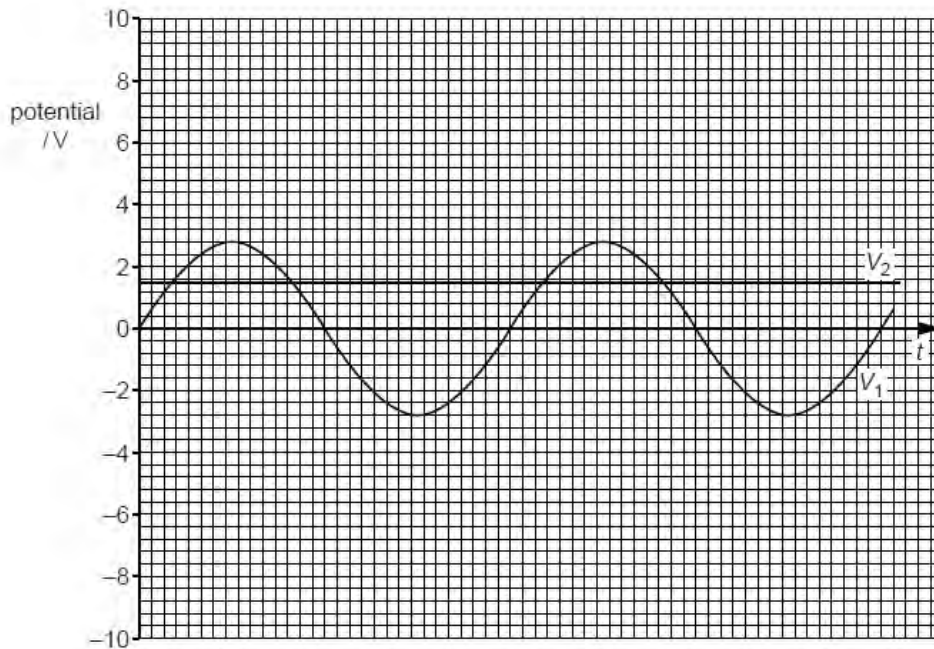

Fig. 9.2

On Fig. 9.2, show the variation with time t of the output potential V_{OUT} .

[4]

F
Exam
U

- (ii) Two light-emitting diodes (LEDs) R and G are connected to the output of the op-amp in Fig. 9.1 such that R emits light for a longer time than G.

On Fig. 9.1, draw the symbols for the two diodes connected to the output of the op-amp and label the diodes R and G. [3]

Q23.

- 9 A student designs an electronic sensor to monitor whether the temperature in a refrigerator is above or below a particular value. The circuit is shown in Fig. 9.1.

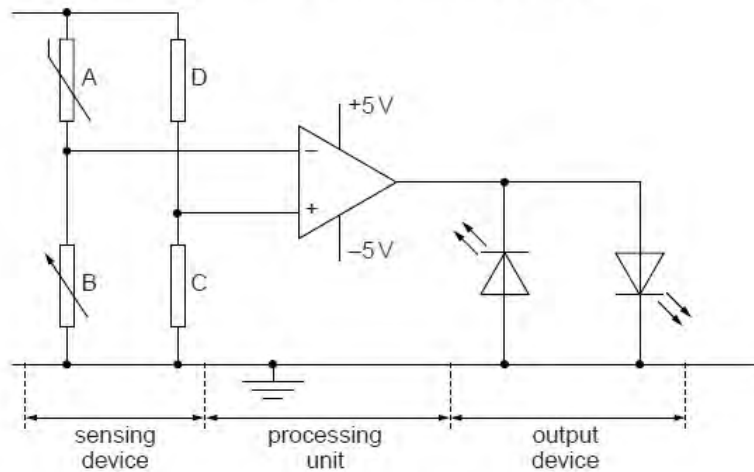

Fig. 9.1

- (a) Name the components used in the output device.

.....[1]

(b) An operational amplifier (op-amp) is used as the processing unit. Describe the function of this processing unit.

.....

 [2]

(c) State the function of

(i) the resistors C and D,

.....
 [1]

(ii) the resistor B.

.....
 [1]

(d) The output device of the circuit in Fig. 9.1 is changed so that the new output device may be used to switch on a high-voltage circuit.

(i) State the component that is used in the new output device.

.....
 [1]

(ii) Draw on Fig. 9.2 to show how the component in (i), together with a diode, are connected so that the high voltage may be switched on when the output of the op-amp is negative.

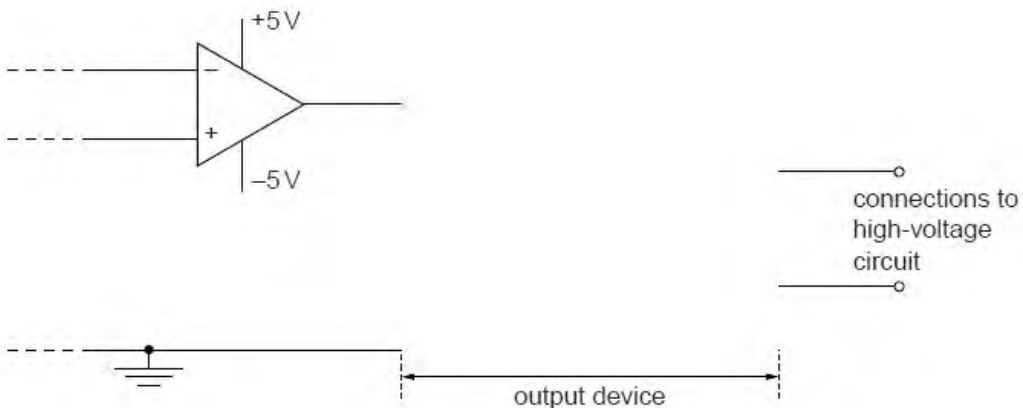

Fig. 9.2

[2]

Q24.

Fr
Exam
U

- 9 An electronic sensor may be represented by the block diagram of Fig. 9.1.

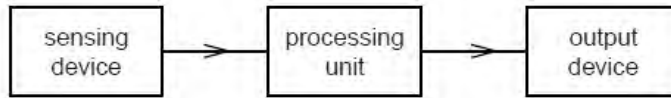

Fig. 9.1

- (a) State the function of the processing unit.

.....
.....
..... [2]

- (b) A student designs a sensing unit for temperature change. A 4V supply, a fixed resistor of resistance $2.5\text{ k}\Omega$ and a thermistor are available. The thermistor has resistance $3.0\text{ k}\Omega$ at 6°C and resistance $1.8\text{ k}\Omega$ at 20°C .

Complete the circuit diagram of Fig. 9.2 to show how the resistor and the thermistor are connected to provide an output that is greater than 2V at 6°C and less than 2V at 20°C . Mark clearly the output V_{OUT} .

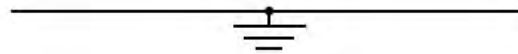

Fig. 9.2

[3]

- (c) Suggest two uses of a relay as part of an output device.

1.
.....
2.
.....

[2]

Q25.

9 (a) State three properties of an ideal operational amplifier (op-amp).

1.
2.
3.

[3]

(b) An amplifier circuit is shown in Fig. 9.1.

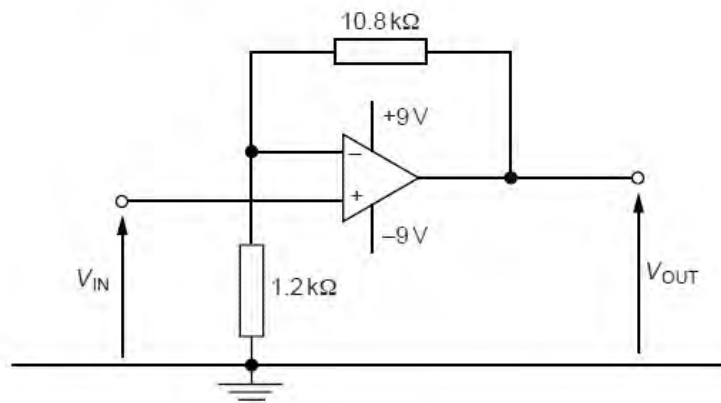

Fig. 9.1

(i) Calculate the gain of the amplifier circuit.

gain = [2]

(ii) The variation with time t of the input potential V_{IN} is shown in Fig. 9.2.

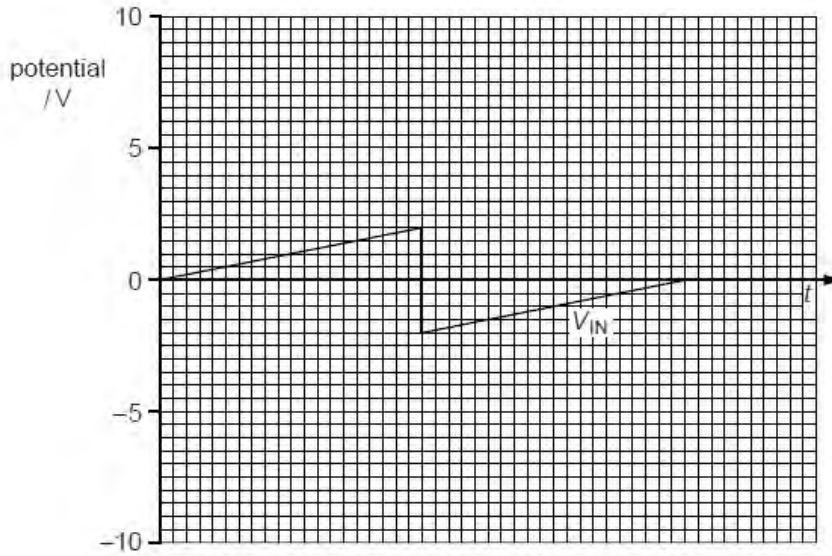

Fig. 9.2

On the axes of Fig. 9.2, show the variation with time t of the output potential V_{OUT} . [3]

For
Examiner's
Use

Q26.

11 (a) A circuit incorporating an ideal operational amplifier (op-amp) is shown in Fig. 11.1.

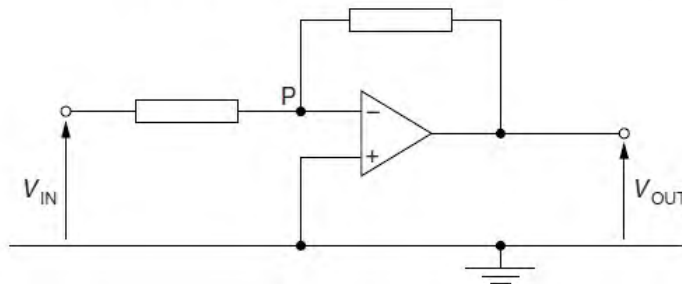

Fig. 11.1

(i) State the name of this circuit.

..... [1]

(ii) Explain why the point P is referred to as a *virtual earth*.

.....

 [3]

(b) The circuit of Fig. 11.1 is modified, as shown in Fig. 11.2.

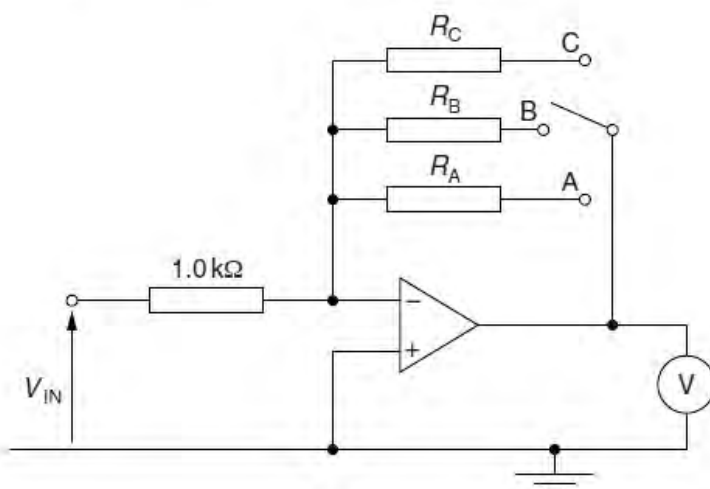

Fig. 11.2

The voltmeter has infinite resistance and its full-scale deflection is 1.0V.

The input potential to the circuit is V_{IN} .

The switch position may be changed in order to have different values of resistance in the circuit.

- (i) The input potential V_{IN} and the switch position are varied. For each switch position, the reading of the voltmeter is 1.0V. Complete Fig. 11.3 for the switch positions shown.

| switch position | V_{IN}/mV | resistance |
|-----------------|--------------------|----------------------------|
| A | 10 | $R_A = \dots\dots\dots$ |
| B | 100 | $R_B = \dots\dots\dots$ |
| C | $\dots\dots\dots$ | $R_C = 1.0\text{ k}\Omega$ |

Fig. 11.3

[3]

- (ii) By reference to your answers in (i), suggest a use for the circuit of Fig. 11.2.

.....

..... [1]

Q27.

- 10 (a) State the function of a comparator circuit incorporating an operational amplifier (op-amp).

.....

 [3]

- (b) An ideal op-amp is incorporated into the circuit of Fig. 10.1.

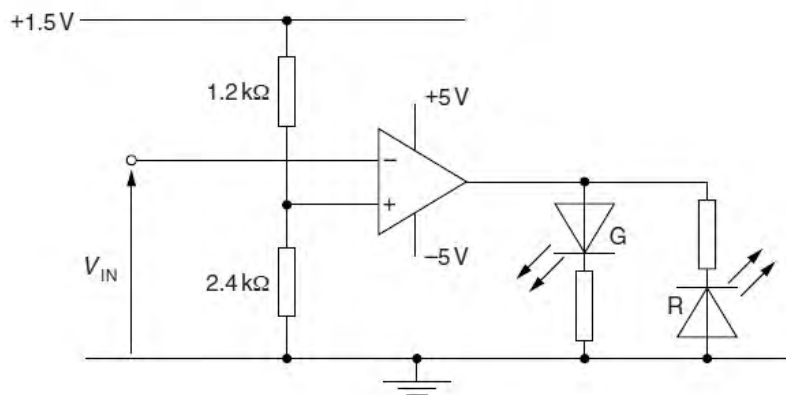

Fig. 10.1

- (i) On Fig. 10.1, draw a circle around the part of the circuit that is being used as an output device. [1]
- (ii) Show that the potential at the non-inverting input of the op-amp is 1.0V.

[1]

- (iii) The variation with time t of the potential V_{IN} at the inverting input of the op-amp is shown in Fig. 10.2.

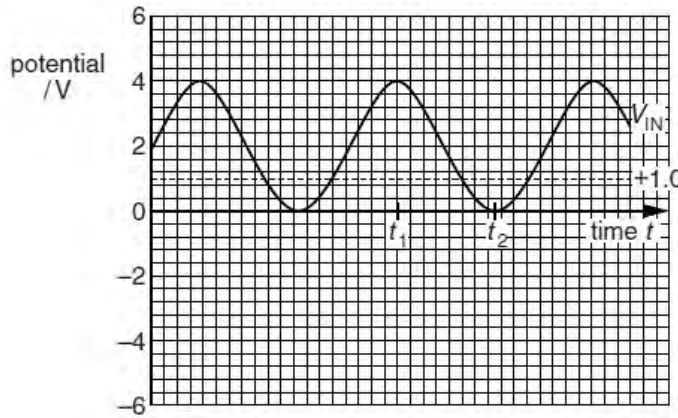

Fig. 10.2

- On the axes of Fig. 10.2, draw the variation with time t of the output potential of the op-amp. [3]
- State whether each diode is emitting light or is not emitting light at time t_1 and at time t_2 .

At time t_1 , diode R will and diode G will

At time t_2 , diode R will and diode G will

[2]

Q28.

- 10 (a) An ideal operational amplifier (op-amp) has infinite open-loop gain and infinite input resistance (impedance).

State three further properties of an ideal op-amp.

1.

.....

2.

.....

3.

.....

[3]

(b) The circuit of Fig. 10.1 is used to detect changes in temperature.

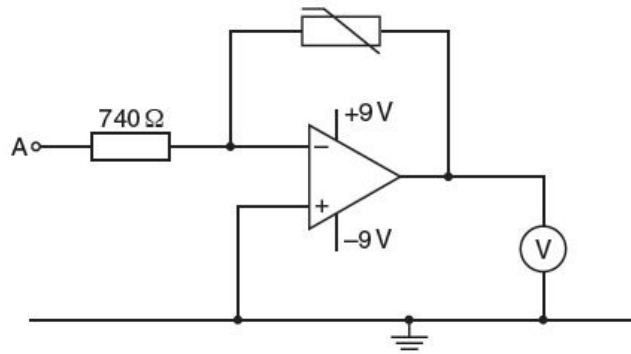

Fig. 10.1

The voltmeter has infinite resistance.

The variation with temperature θ of the resistance R of the thermistor is shown in Fig. 10.2.

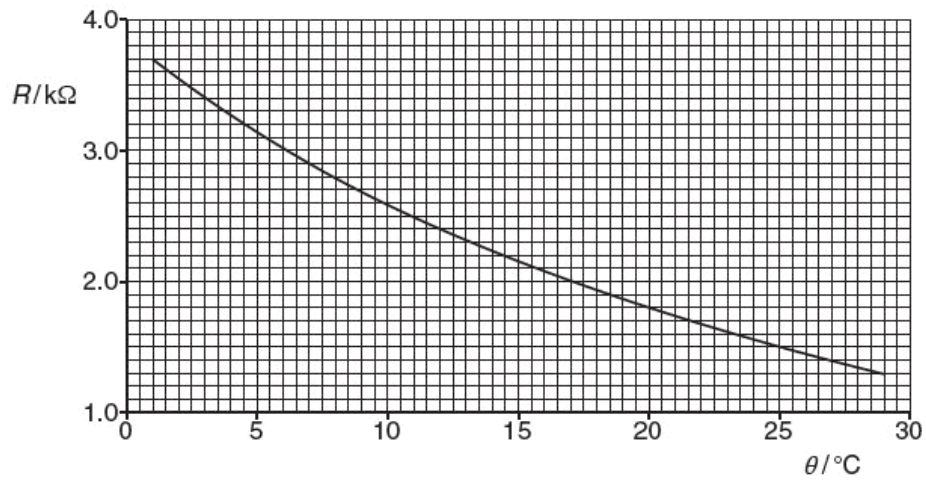

Fig. 10.2

- (i) When the thermistor is at a temperature of 1.0°C , the voltmeter reads $+1.0\text{ V}$.

Show that, for the thermistor at 1.0°C , the potential at A is -0.20 V .

[4]

- (ii) The potential at A remains at -0.20 V .

Determine the voltmeter reading for a thermistor temperature of 15°C .

voltmeter reading = V [2]

- (c) The voltmeter reading for a thermistor temperature of 29°C is 0.35 V .

- (i) Assuming a linear change of voltmeter reading with change of temperature over the range 1°C to 29°C , calculate the voltmeter reading at 15°C .

voltmeter reading = V [1]

- (ii) Suggest why your answers in (b)(ii) and (c)(i) are not the same.

.....
..... [1]

Q29.

10 An electronic sensor may be represented by the block diagram of Fig. 10.1.

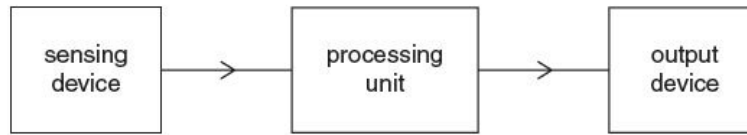

Fig. 10.1

(a) State suitable sensing devices, one in each case, for the detection of

(i) change of temperature,

..... [1]

(ii) pressure changes in a sound wave.

..... [1]

(b) The ideal operational amplifier (op-amp) shown in Fig. 10.2 is to be used as a processing unit.

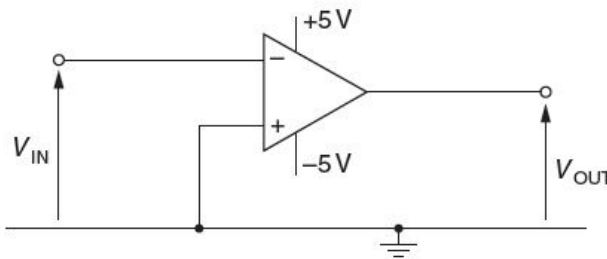

Fig. 10.2

(i) State the value of the output potential V_{OUT} for an input potential V_{IN} of +0.5V. Explain your answer.

.....
.....
.....
..... [3]

- (ii) A sensing device produces a variable potential V_{IN} . The variation with time t of V_{IN} is shown in Fig. 10.3.

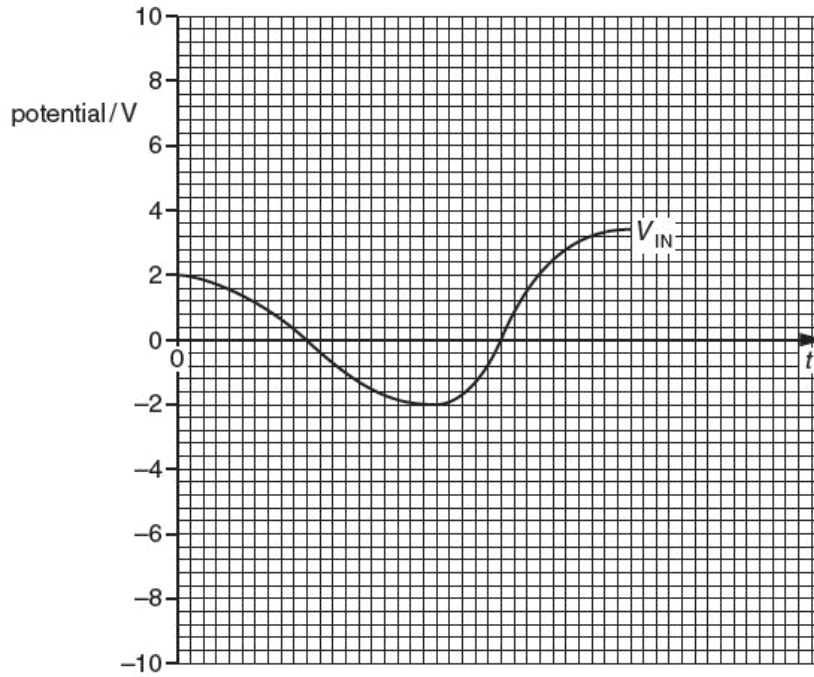

Fig. 10.3

On the axes of Fig. 10.3, sketch the variation with time t of the output potential V_{OUT} . [3]

