

Electricity

May 02

1. The graphs show the variation with potential difference V of the current I for three circuit elements.

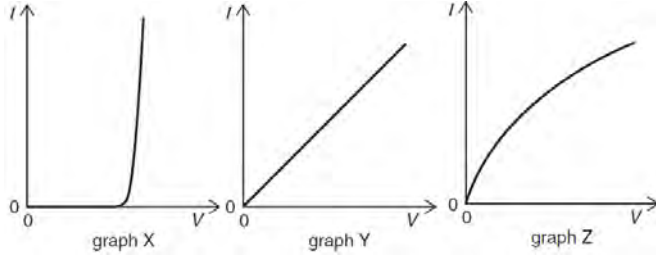

The three circuit elements are a metal wire at constant temperature, a semiconductor diode and a filament lamp. Which row of the table correctly identifies these graphs?

	metal wire at constant temperature	semiconductor diode	filament lamp
A	X	Z	Y
B	Y	X	Z
C	Y	Z	X
D	Z	X	Y

2. In the circuit below, the battery converts an amount E of chemical energy to electrical energy when charge Q passes through the resistor in time t .

Which expressions give the e.m.f. of the battery and the current in the resistor?

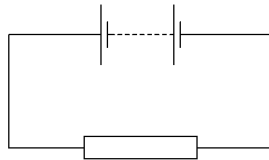

	e.m.f.	current
A	EQ	Q/t
B	EQ	Qt
C	E/Q	Q/t
D	E/Q	Qt

3. The filament of a 240 V, 100W electric lamp heats up from room temperature to its operating temperature. As it heats up, its resistance increases by a factor of 16. What is the resistance of this lamp at room temperature?

- A** 36Ω **B** 580Ω **C** 1.5 kΩ **D** 9.2 kΩ

4. The diagrams show connected wires which carry currents I_1 , I_2 , I_3 and I_4 . The currents are related by the equation $I_1 + I_2 = I_3 + I_4$. To which diagram does this equation apply?

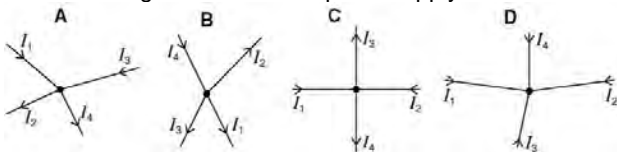

5. Which path shows a possible movement of an electron in the electric field shown?

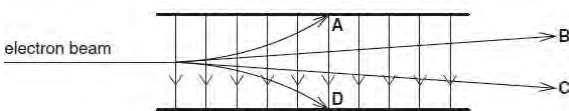

6. When four identical lamps P, Q, R and S are connected as shown in diagram 1, they have normal brightness.

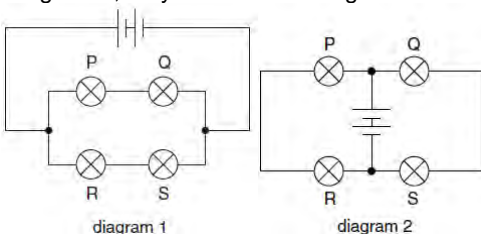

When the four lamps are connected as shown in diagram 2, which statement is correct?

- A** The lamps do not light.
B The lamps are less bright than normal.
C The lamps have normal brightness.
D The lamps are brighter than normal.

7. A potential divider is used to give outputs of 2 V and 3 V from a 5 V source, as shown.

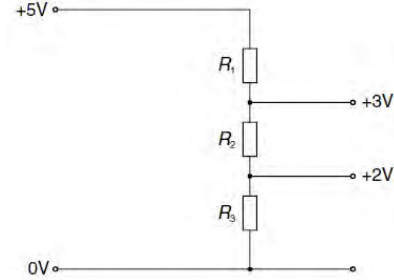

What are possible values for the resistances R_1 , R_2 and R_3 ?

	$R_1/k\Omega$	$R_2/k\Omega$	$R_3/k\Omega$
A	2	1	5
B	3	2	2
C	4	2	4
D	4	6	10

8. Two parallel conducting plates are connected to a battery, one plate to the positive terminal and the other plate to the negative. The plate separation is gradually increased, the plates remaining connected to the battery. Which graph shows how the electric field E between the plates depends on the plate separation x ?

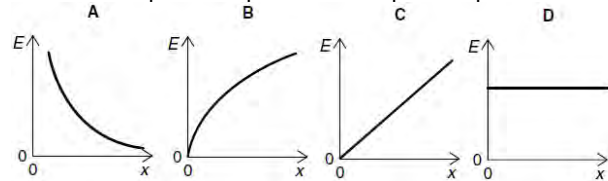

Nov 02

9. The combined resistance R_T of two resistors of resistances R_1 and R_2 connected in parallel is given by the formula

$$\frac{1}{R_T} = \frac{1}{R_1} + \frac{1}{R_2}$$

Which statement is used in the derivation of this formula?

- A** The currents through the two resistors are equal.
B The potential difference across each resistor is the same.
C The supply current is split between the two resistors in the same ratio as the ratio of their resistances.
D The total power dissipated is the sum of the powers dissipated in the two resistors separately.

10. The graph shows how the current through a lamp filament varies with the potential difference across it.

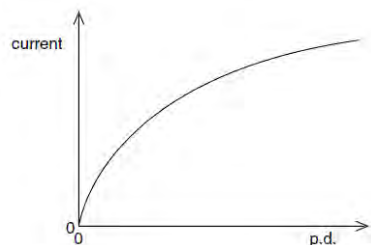

Which statement explains the shape of this graph?

- A** As the filament temperature rises, electrons can pass more easily through the filament.
B It takes time for the filament to reach its working temperature.
C The power output of the filament is proportional to the square of the current through it.
D The resistance of the filament increases with a rise in temperature.

11. The variation with potential difference V of the current I in a semiconductor diode is shown below.

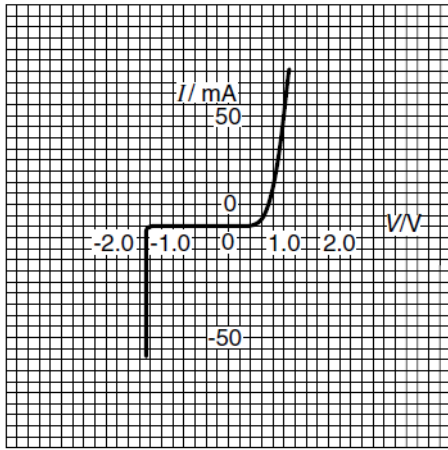

What is the resistance of the diode for applied potential differences of $+1.0\text{ V}$ and -1.0 V ?

	resistance	
	at $+1.0\text{ V}$	at -1.0 V
A	$20\ \Omega$	infinite
B	$20\ \Omega$	zero
C	$0.05\ \Omega$	infinite
D	$0.05\ \Omega$	zero

12. At a circuit junction, a current I divides into currents I_1 , I_2 & I_3 .

These currents are related by the equation $I = I_1 + I_2 + I_3$.

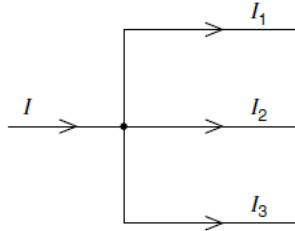

Which law does this statement illustrate and on what principle is the law based?

- A Kirchhoff's first law based on conservation of charge
- B Kirchhoff's first law based on conservation of energy
- C Kirchhoff's second law based on conservation of charge
- D Kirchhoff's second law based on conservation of energy

13. Which equation is used to define resistance?

- A power = (current)² x resistance
- B resistivity = resistance x area ÷ length
- C potential difference = current x resistance
- D energy = (current)² x resistance x time

14. In the potentiometer circuit below, the moveable contact is placed at N on the bare wire XY, such that the galvanometer shows zero deflection.

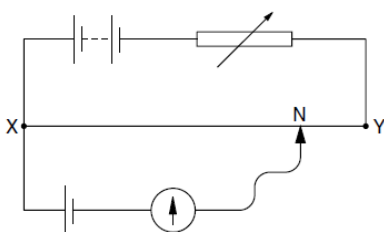

The resistance of the variable resistor is now increased. What is the effect of this increase on the potential difference across the wire XY and on the position of the moveable contact for zero deflection?

	potential difference across XY	position of moveable contact
A	increases	nearer to X
B	increases	nearer to Y
C	decreases	nearer to X
D	decreases	nearer to Y

15. Six resistors, each of resistance $5\ \Omega$, are connected to a 2 V cell of negligible internal resistance.

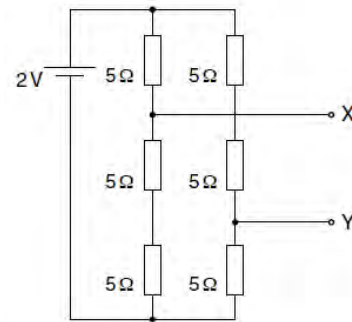

What is the potential difference between terminals X and Y?

- A $\frac{2}{3}\text{ V}$
- B $\frac{8}{9}\text{ V}$
- C $\frac{4}{3}\text{ V}$
- D 2 V

16. Which diagram shows the electric field pattern of an isolated negative point charge?

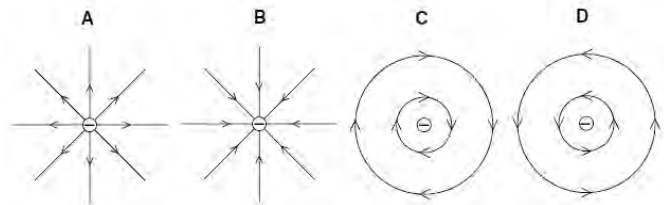

June 03

17. What physical quantity would result from a calculation in which a potential difference is multiplied by an electric charge?

- A electric current
- B electric energy
- C electric field strength
- D electric power

18. The current in a component is reduced uniformly from 100 mA to 20 mA over a period of 8.0 s .

What is the charge that flows during this time?

- A 160 mC
- B 320 mC
- C 480 mC
- D 640 mC

19. The sum of the electrical currents into a point in a circuit is equal to the sum of the currents out of the point.

Which of the following is correct?

- A This is Kirchhoff's first law, which results from the conservation of charge.
- B This is Kirchhoff's first law, which results from the conservation of energy.
- C This is Kirchhoff's second law, which results from the conservation of charge.
- D This is Kirchhoff's second law, which results from the conservation of energy.

20. The e.m.f. of the cell in the following circuit is 9.0 V . The reading on the high-resistance voltmeter is 7.5 V .

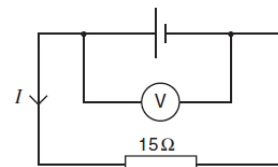

What is the current I ?

- A 0.1 A
- B 0.5 A
- C 0.6 A
- D 2.0 A

21. The diagram shows an arrangement of four resistors.

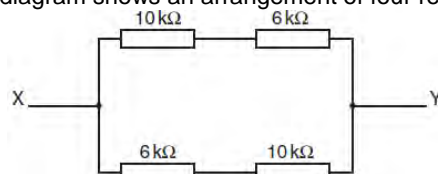

What is the resistance between X and Y?

- A $4\text{ k}\Omega$
- B $8\text{ k}\Omega$
- C $16\text{ k}\Omega$
- D $32\text{ k}\Omega$

22. The diagram shows a potential divider connected to a 9.0 V supply of negligible internal resistance.

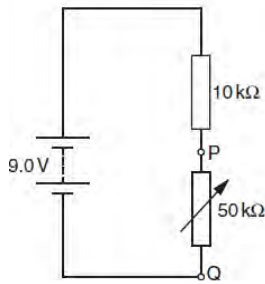

What range of voltages can be obtained between P and Q?
A zero to 1.5V **B** zero to 7.5V
C 1.5 V to 7.5V **D** 1.5 V to 9.0V

23. An electric field exists in the space between two charged metal plates.

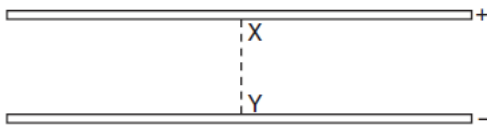

Which of the following graphs shows the variation of electric field strength E with distance d from X along the line XY?

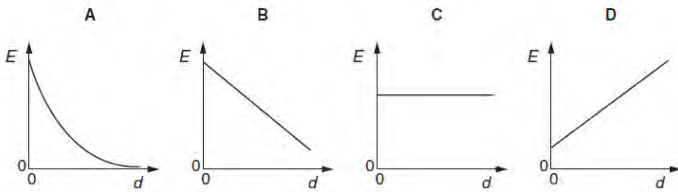

24. The diagram shows two metal plates P and Q between which there is a potential difference of 700V. Plate Q is earthed.

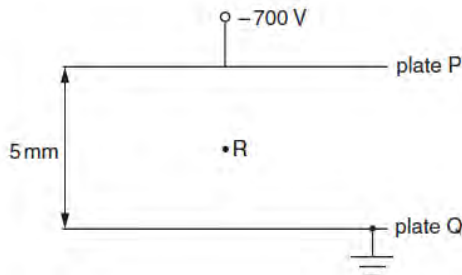

What is the magnitude and direction of the electric field at point R?
A $1.4 \times 10^2 \text{ NC}^{-1}$ from P towards Q
B $1.4 \times 10^2 \text{ NC}^{-1}$ from Q towards P
C $1.4 \times 10^5 \text{ NC}^{-1}$ from P towards Q
D $1.4 \times 10^5 \text{ NC}^{-1}$ from Q towards P

25. A positive charge and a negative charge of equal magnitude are placed a short distance apart.

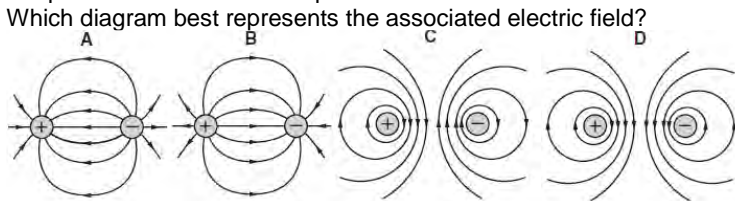

Nov 03

26. Which electrical quantity would be the result of a calculation in which energy is divided by charge?

A current **B** potential difference
C power **D** resistance

27. A wire carries a current of 2.0 amperes for 1.0 hour. How many electrons pass a point in the wire in this time?

A 1.2×10^{-15} **B** 7.2×10^3
C 1.3×10^{19} **D** 4.5×10^{22}

28. The diagram shows a circuit in which the battery has negligible internal resistance.

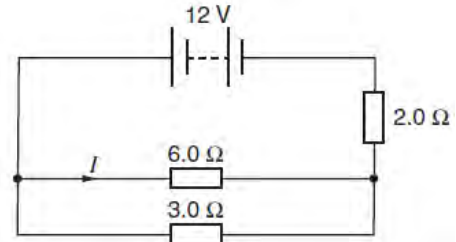

What is the value of the current I ?
A 1.0 A **B** 1.6 A **C** 2.0 A **D** 3.0A

29. The diagram shows currents I_1, I_2, I_3, I_4 and I_5 in different branches of a circuit.

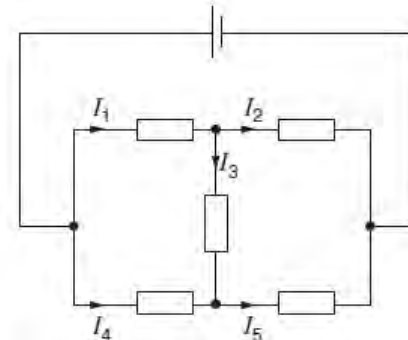

Which one of the following is correct?

A $I_1 = I_2 + I_3$ **B** $I_2 = I_1 + I_3$
C $I_3 = I_4 + I_5$ **D** $I_4 = I_5 + I_3$

30. Which diagram shows a potential divider circuit that can vary the voltage across the lamp?

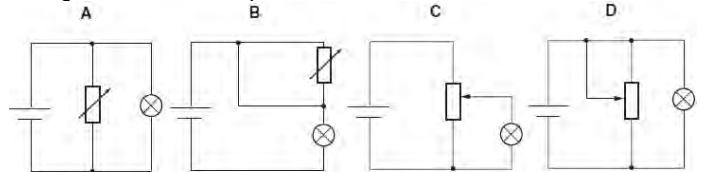

31. The diagram shows two circuits. In these circuits, only the internal resistances differ.

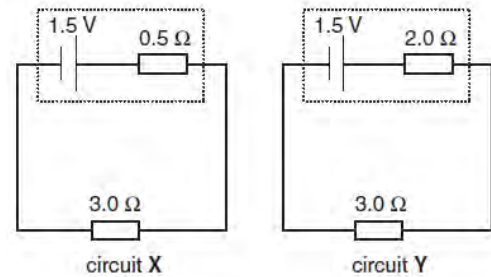

Which line in the table is correct?

	potential difference across 3.0Ω resistor	power dissipated in 3.0Ω resistor
A	greater in X than in Y	less in X than in Y
B	greater in X than in Y	greater in X than in Y
C	less in X than in Y	less in X than in Y
D	less in X than in Y	greater in X than in Y

32. Which diagram represents the electric field of a negative point charge $-q$?

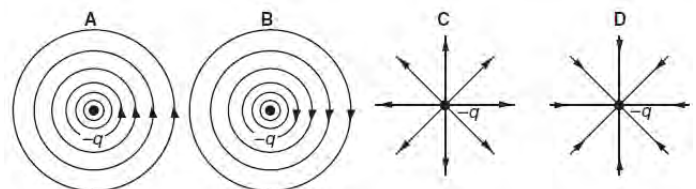

33. A potential difference V is applied between two parallel plates a small distance d apart, and produces an electric field of strength E between the plates.



What is the electric field strength between the plates when both V and d are doubled?

- A $E/4$ B E C $2E$ D $4E$

34. In the circuit below, the distance between the two parallel plates is 2.0×10^{-3} m. An electron is situated between the plates.

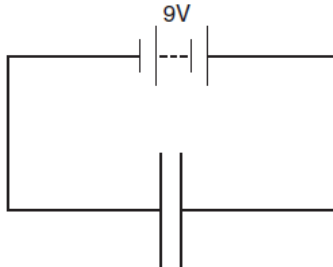

What is the force on the electron?

- A 3.2×10^{-22} N B 2.9×10^{-21} N
C 8.9×10^{-18} N D 7.2×10^{-16} N

June 04

35. The diagram shows an electron in a uniform electric field. In which direction will the field accelerate the electron.

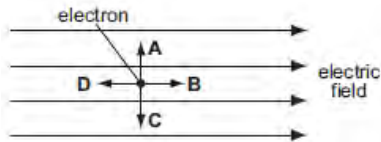

36. The diagram shows a thundercloud whose base is 500 m above the ground.

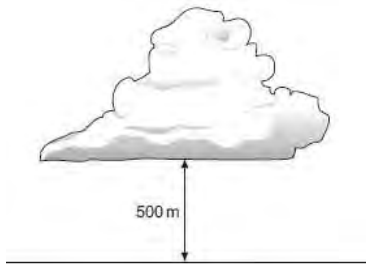

The potential difference between the base of the cloud and the ground is 200 MV. A raindrop with a charge of 4.0×10^{-12} C is in the region between the cloud and the ground.

What is the electrical force on the raindrop?
A 1.6×10^{-6} N B 8.0×10^{-4} N
C 1.6×10^{-3} N D 0.40 N

37. Two wires made of the same material and of the same length are connected in parallel to the same voltage supply. Wire P has a diameter of 2 mm. Wire Q has a diameter of 1 mm.

What is the ratio $\frac{\text{current in P}}{\text{current in Q}}$?

- A $\frac{1}{4}$ B $\frac{1}{2}$ C 2 D 4

38. What is an equivalent unit to 1 volt?

- A 1 J A^{-1} B 1 J C^{-1} C 1 W C^{-1} D 1 W s^{-1}

39. The terminal voltage of a battery is observed to fall when the battery supplies a current to an external resistor.

What quantities are needed to calculate the fall in voltage?

- A the battery's e.m.f. and its internal resistance
B the battery's e.m.f. and the current
C the current and the battery's internal resistance
D the current and the external resistance

40. The potential difference between point X and point Y is 20 V. The time taken for charge carriers to move from X to Y is 15 s, and, in this time, the energy of the charge carriers changes by 12 J. What is the current between X and Y?

- A 0.040 A B 0.11 A C 9.0 A D 25 A

41. The diagram shows a battery, a fixed resistor, an ammeter and a variable resistor connected in series. A voltmeter is connected across the fixed resistor.

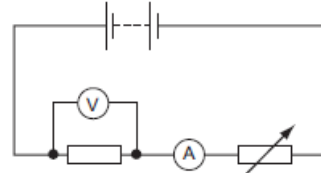

The value of the variable resistor is reduced. Which correctly describes the changes in the readings of the ammeter and of the voltmeter?

- | | ammeter | voltmeter |
|---|----------|-----------|
| A | decrease | decrease |
| B | decrease | increase |
| C | increase | decrease |
| D | increase | increase |

42. Kirchhoff's two laws for electric circuits can be derived by using conservation laws.

On which conservation laws do Kirchhoff's laws depend?

	Kirchhoff's first law	Kirchhoff's second law
A	charge	current
B	charge	energy
C	current	mass
D	energy	current

43. The diagram shows a parallel combination of three resistors. The total resistance of the combination is 3 Ω .

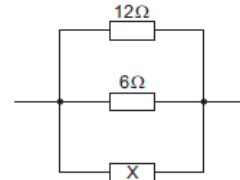

What is the resistance of resistor X?

- A 2 Ω B 3 Ω C 6 Ω D 12 Ω

Nov 04

44. An electron is situated in a uniform electric field, as shown in the diagram.

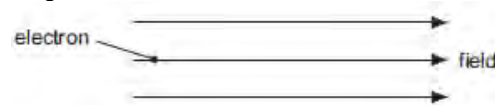

What is the direction of the electric force acting on the electron?
A downwards B to the left C to the right D upwards

45. Two parallel, conducting plates with air between them are placed close to one another. The top plate is given a negative charge and the bottom one is earthed.

Which diagram best represents the distribution of charges and the field in this situation?

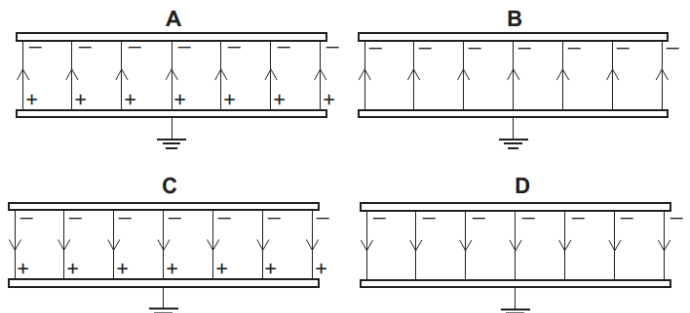

46. In a uniform electric field, which statement is correct?
 A All charged particles experience the same force.
 B All charged particles move with the same velocity.
 C All electric field lines are directed towards positive charges.
 D All electric field lines are parallel.

47. Which of the following describes the electric potential difference between two points in a wire that carries a current?
 A the force required to move a unit positive charge between the points
 B the ratio of the energy dissipated between the points to the current
 C the ratio of the power dissipated between the points to the current
 D the ratio of the power dissipated between the points to the charge moved

48. The diagram shows four heaters and the current in each. Which heater has the greatest power dissipation?

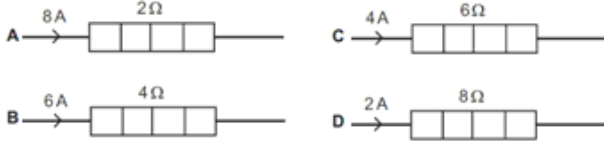

49. When a potential difference V is applied between the ends of a wire of diameter d and length l , the current in the wire is I . What is the current when a potential difference of $2V$ is applied between the ends of a wire of the same material of diameter $2d$ and the length $2l$? Assume that the temperature of the wire remains constant.

- A I B $2I$ C $4I$ D $8I$

50. The resistance of a thermistor decreases significantly as its temperature increases. The thermistor is kept in air. The air is at room temperature. Which graph best represents the way in which the current I in the thermistor depends upon the potential difference V across it?

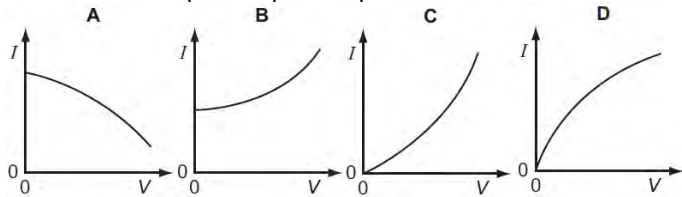

51. The diagram shows a junction in a circuit where three wires P, Q and R meet. The currents in P and Q are 1 A and 3 A respectively, in the directions shown.

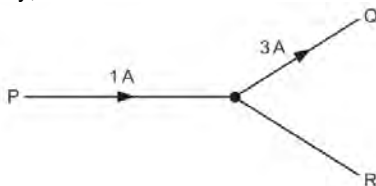

- How many coulombs of charge pass a given point in wire R in 5 s ?

- A 0.4 B 0.8 C 2 D 10

52. The diagram shows a potential divider circuit designed to provide a variable output p.d.

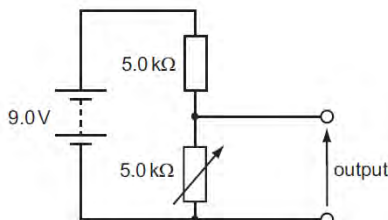

- Which gives the available range of output p.d.?

	maximum output	minimum output
A	3.0 V	0
B	4.5 V	0
C	9.0 V	0
D	9.0 V	4.5 V

53. In the circuit shown, the ammeters have negligible resistance and the voltmeters have infinite resistance.

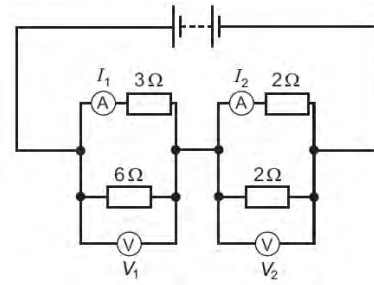

- The readings on the meters are I_1 , I_2 , V_1 and V_2 , as labelled on the diagram.

- Which is correct?

- A $I_1 > I_2$ and $V_1 > V_2$ C $I_1 < I_2$ and $V_1 > V_2$
 B $I_1 > I_2$ and $V_1 < V_2$ D $I_1 < I_2$ and $V_1 < V_2$

June 05

54. The diagram shows a pair of metal plates 4.0 mm apart connected to a 9.0 V battery.

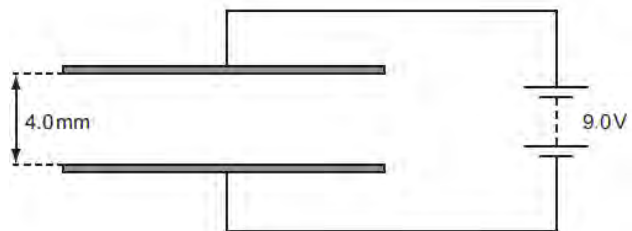

- What is the electric field between the plates?

- A $4.4 \times 10^{-4}\text{ N C}^{-1}$ B $3.6 \times 10^{-2}\text{ N C}^{-1}$
 C 36 N C^{-1} D $2.3 \times 10^3\text{ N C}^{-1}$

55. Which diagram represents the electric field in the vicinity of a positive electric charge of magnitude Q ?

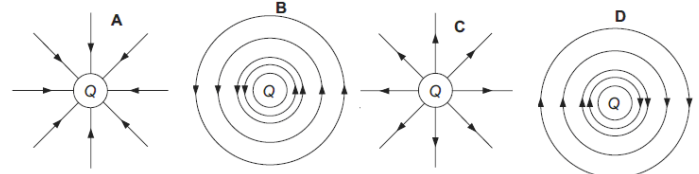

56. A copper wire of cross-sectional area 2.0 mm^2 carries a current of 10 A .

- How many electrons pass through a given cross-section of the wire in one second?

- A 1.0×10^{17} B 5.0×10^6 C 6.3×10^{19} D 3.1×10^{25}

57. A cylindrical piece of a soft, electrically-conducting material has resistance R . It is rolled out so that its length is doubled but its volume stays constant. What is its new resistance?

- A $\frac{R}{2}$ B R C $2R$ D $4R$

58. The I - V characteristics of two electrical components P and Q are shown below.

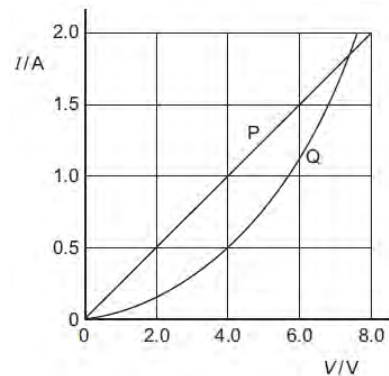

- Which statement is correct?

- A P is a resistor and Q is a filament lamp.
 B The resistance of Q increases as the current in it increases.
 C At 1.9 A the resistance of Q is approximately half that of P.
 D At 0.5 A the power dissipated in Q is double that in P.

59. Which electrical component is represented by the following symbol?

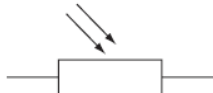

- A a diode B a LDR C a resistor D a thermistor

60. The diagram shows a circuit with four voltmeter readings V_1 , V_2 and V_3 .

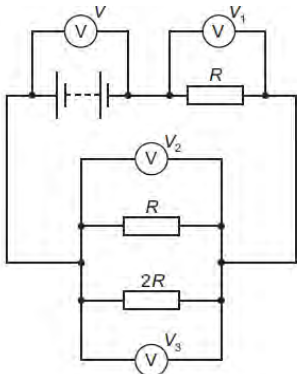

Which equation relating the voltmeter readings must be true?

- A $V = V_1 + V_2 + V_3$ C $V_3 = 2(V_2)$
 B $V + V_1 = V_2 + V_3$ D $V - V_1 = V_3$

61. In the circuit below, P is a potentiometer of total resistance 10Ω and Q is a fixed resistor of resistance 10Ω . The battery has an e.m.f. of 4.0 V and negligible internal resistance. The voltmeter has a very high resistance. The slider on the potentiometer is moved from X to Y and a graph of voltmeter reading V is plotted against slider position.

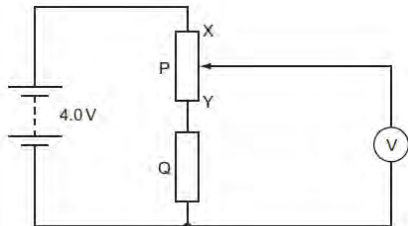

Which graph is obtained?

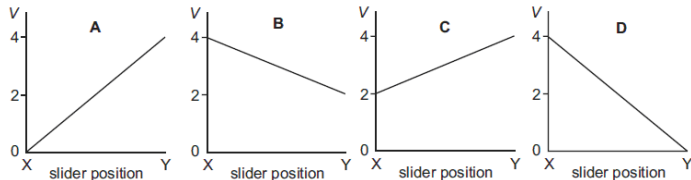

Nov 05

62. A positively charged particle is projected into a region of uniform electric field E . Which diagram represents the motion of the particle in the electric field?

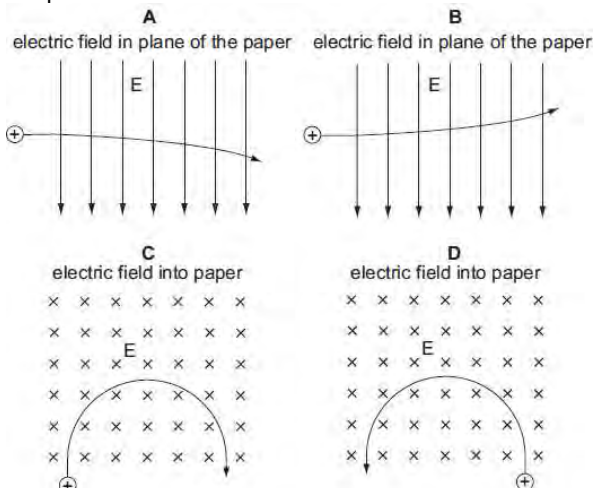

63. Two large parallel plates X and Z are placed 5.0 mm apart and connected as shown to the terminals of a 200 volt d.c. supply.

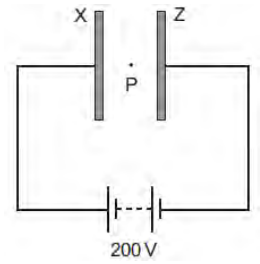

A small oil drop at P carries one excess electron.

What is the magnitude of the electrostatic force acting on the oil drop due to the electric field between the plates?

- A $6.4 \times 10^{-15} \text{ N}$ B $6.4 \times 10^{-18} \text{ N}$ C $1.6 \times 10^{-19} \text{ N}$ D $4.0 \times 10^{-24} \text{ N}$

64. In each arrangement of resistors, the ammeter has a resistance of 2Ω .

Which arrangement gives the largest reading on the ammeter when the same potential difference is applied between points P and Q?

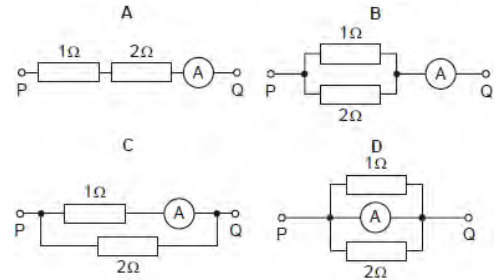

65. A source of e.m.f. of 9.0 mV has an internal resistance of 6.0Ω . It is connected across a galvanometer of resistance 30Ω .

What will be the current in the galvanometer?
 A $250 \mu\text{A}$ B $300 \mu\text{A}$ C 1.5 mA D 2.5 mA

66. The graphs show the variation with potential difference V of the current I for three circuit components.

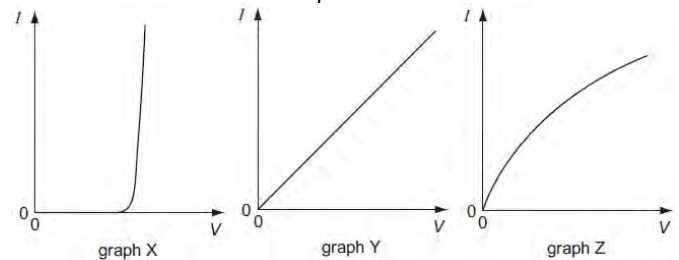

The components are a metal wire at constant temperature, a semiconductor diode and a filament lamp.

Which row of the table correctly identifies these graphs?

	metal wire at constant temperature	semiconductor diode	filament lamp
A	X	Z	Y
B	Y	X	Z
C	Y	Z	X
D	Z	X	Y

67. Tensile strain may be measured by the change in electrical resistance of a strain gauge. A strain gauge consists of folded fine metal wire mounted on a flexible insulating backing sheet. The strain gauge is firmly attached to the specimen, so that the strain in the metal wire is always identical to that in the specimen.

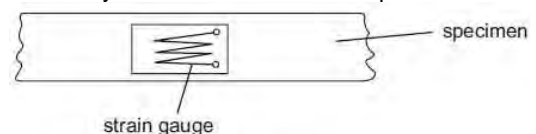

When the strain in the specimen is increased, what happens to the resistance of the wire?

- A It decreases, because the length decreases and the cross-sectional area increases.
 B It decreases, because the length increases and the cross-sectional area decreases.
 C It increases, because the length decreases and the cross-sectional area increases.
 D It increases, because the length increases and the cross-sectional area decreases.

68. The graph shows how the electric current I through a conducting liquid varies with the potential difference V across it. At which point on the graph does the liquid have the smallest resistance?

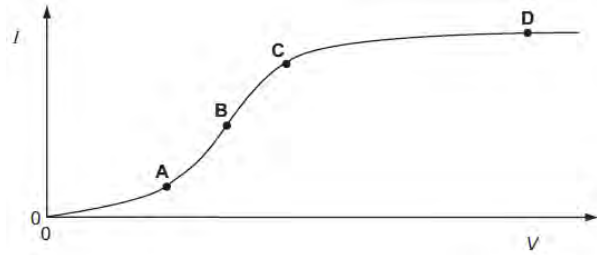

69. An electrical component has the following circuit symbol.

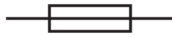

What does this symbol represent?

- A variable resistor (rheostat)
- B fuse
- C light-dependent resistor
- D thermistor

70. Three resistors are connected in series with a battery as shown in the diagram. The battery has negligible internal resistance.

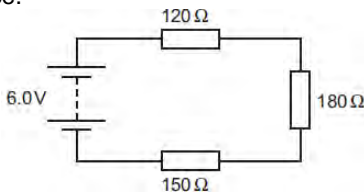

What is the potential difference across the 180 Ω resistor?

- A 1.6 V
- B 2.4 V
- C 3.6 V
- D 6.0 V

71. In the circuit below, the reading V_T on the voltmeter changes from high to low as the temperature of the thermistor changes. The reading V_L on the voltmeter changes from high to low as the level of light on the light-dependent resistor (LDR) changes.

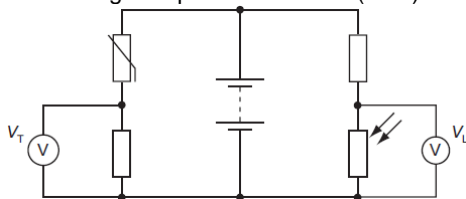

The readings on V_T and V_L are both high.

What are the conditions of temperature and light level?

	temperature	light level
A	low	low
B	low	high
C	high	low
D	high	high

June 06

72. Two parallel metal plates are at potentials of +800 V and +1300 V. Which diagram best shows the electric field between the metal plates?

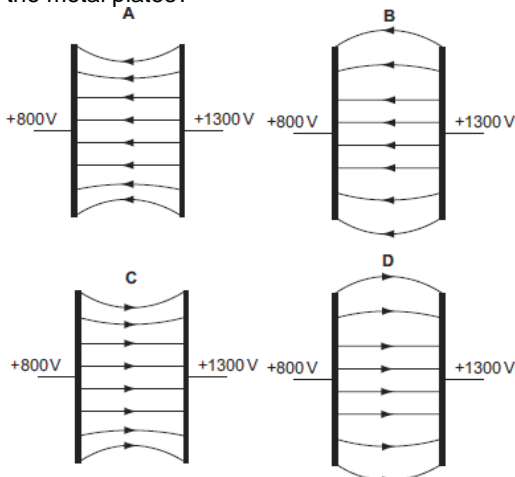

73. An electron of charge e is introduced between two metal plates a distance d apart. A potential difference V is applied to the plates as shown in the diagram.

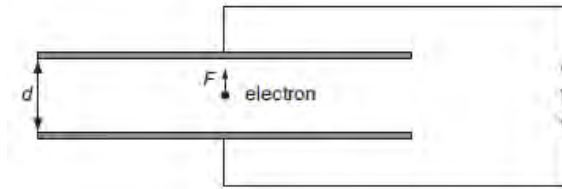

Which expression gives the electric force F on the electron?

- A $\frac{eV}{d}$
- B eVd
- C $\frac{V}{ed}$
- D $\frac{dV}{e}$

74. The current in the circuit is 4.8 A.

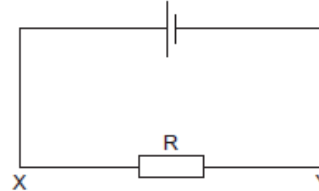

What is the rate of flow and the direction of flow of electrons through the resistor R ?

- A $3.0 \times 10^{19} \text{ s}^{-1}$ in direction X to Y
- B $6.0 \times 10^{18} \text{ s}^{-1}$ in direction X to Y
- C $3.0 \times 10^{19} \text{ s}^{-1}$ in direction Y to X
- D $6.0 \times 10^{18} \text{ s}^{-1}$ in direction Y to X

75. Which equation is used to define resistance?

- A energy = (current)² × resistance × time
- B potential difference = current × resistance
- C power = (current)² × resistance
- D resistivity = resistance × area ÷ length

76. A p.d. of 12 V is connected between P and Q.

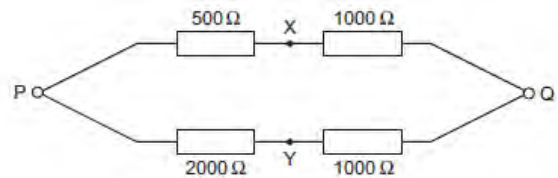

What is the p.d. between X and Y?

- A 0 V
- B 4 V
- C 6 V
- D 8 V

77. The diagram shows a low-voltage circuit for heating the water in a fish tank.

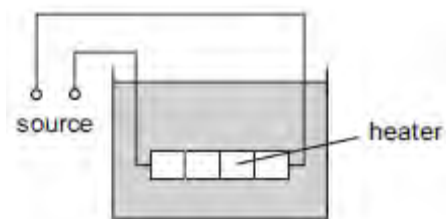

The heater has a resistance of 3.0 Ω. The voltage source has an e.m.f. of 12 V and an internal resistance of 1.0 Ω.

At what rate does the voltage source supply energy to the heater?

- A 27 W
- B 36 W
- C 48 W
- D 64 W

78. The diagram shows an arrangement of resistors.

Y

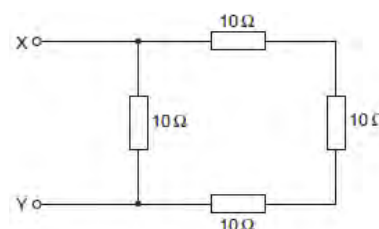

What is the total electrical resistance between X and Y?

- A less than 1 Ω
- B between 1 Ω and 10 Ω
- C between 10 Ω and 30 Ω
- D 40 Ω

79. When four identical lamps P, Q, R and S are connected as shown in diagram 1, they have normal brightness.

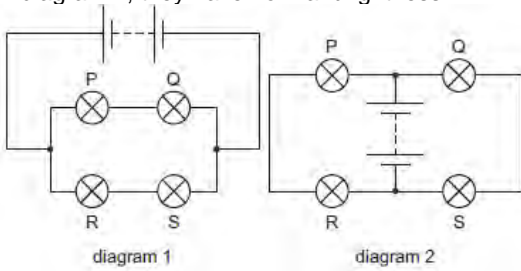

The four lamps and the battery are then connected as shown in diagram 2. Which statement is correct?

- A. The lamps do not light.
- B. The lamps are less bright than normal.
- C. The lamps have normal brightness.
- D. The lamps are brighter than normal.

80. The diagram shows a light-dependent resistor (LDR) and a thermistor forming a potential divider.

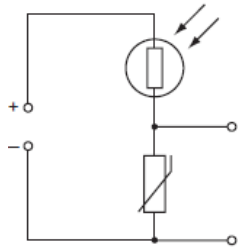

Under which set of conditions will the potential difference across the thermistor have the greatest value?

	illumination	temperature
A	low	low
B	high	low
C	low	high
D	high	high

Nov 06.

81. An electric railway locomotive has a maximum mechanical output power of 4.0 MW. Electrical power is delivered at 25 kV from overhead wires. The overall efficiency of the locomotive in converting electrical power to mechanical power is 80%. What is the current from the overhead wires when the locomotive is operating at its maximum power?

- A 130 A B 160 A C 200 A D 250 A

82. An electric field exists in the space between two charged metal plates.

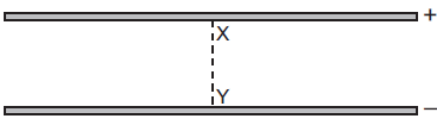

Which graph shows the variation of electric field strength E with distance d from X along the line XY?

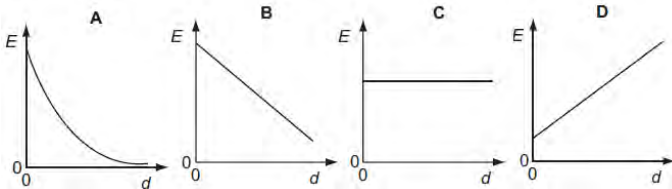

83. Four point charges, each of charge Q, are placed on the edge of an insulating disc of radius r. The frequency of rotation of the disc is f.

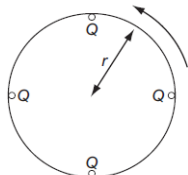

What is the equivalent electric current at the edge of the disc?

- A $4Qf$ B $\frac{4Q}{f}$ C $8\pi rQf$ D $\frac{2Qf}{\pi r}$

84. Which graph shows the I – V characteristic of a filament lamp?

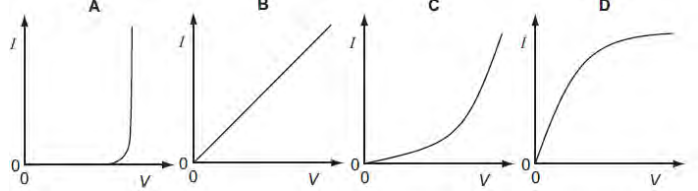

85. An electrical component has a potential difference V across it and a current I through it. A graph of I against V is drawn and is marked in three sections WX, XY and YZ.

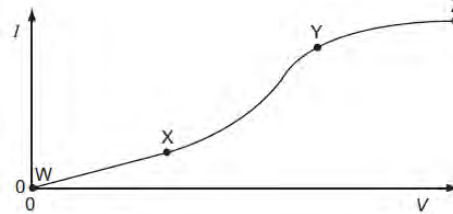

In which ways does the resistance of the component vary within each of the three sections?

	WX	XY	YZ
A	constant	decreases	increases
B	constant	increases	increases
C	increases	decreases	constant
D	increases	increases	decreases

86. The diagram shows a potentiometer and a fixed resistor connected across a 12 V battery of negligible internal resistance.

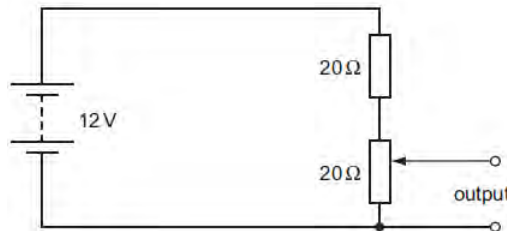

The fixed resistor and the potentiometer each have resistance 20 Ω. The circuit is designed to provide a variable output voltage. What is the range of output voltages?

- A 0 – 6 V B 0 – 12 V C 6 – 12 V D 12 – 20 V

87. The resistance of a device is designed to change with temperature. What is the device?

- A a light-dependent resistor B a potential divider
- C a semiconductor diode D a thermistor

88. The diagram represents a circuit.

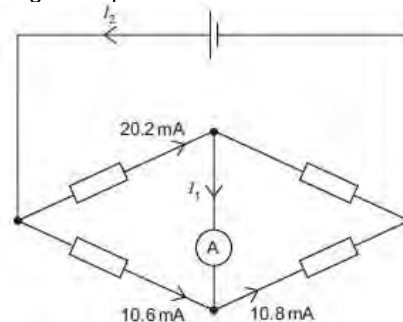

Some currents have been shown on the diagram. What are the currents I₁ and I₂?

	I ₁	I ₂
A	0.2 mA	10.8 mA
B	0.2 mA	30.8 mA
C	-0.2 mA	20.0 mA
D	-0.2 mA	30.8 mA

89. Which circuit has a resistance of $40\ \Omega$ between the terminals?

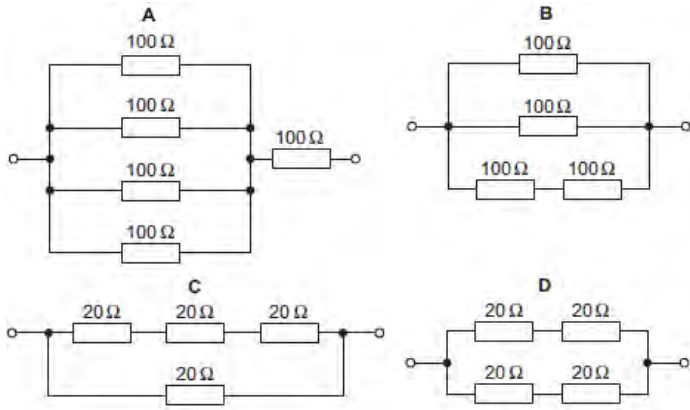

June 07

90. Which diagram represents the electric field of a negative point charge, shown by \bullet ?

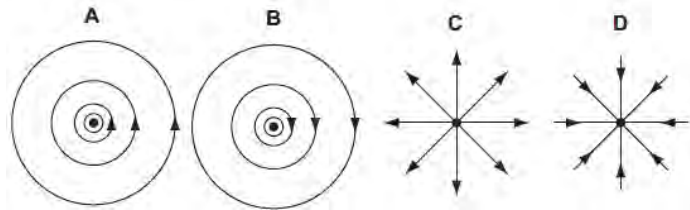

91. An electron, travelling horizontally at constant speed in a vacuum, enters a vertical electric field between two charged parallel plates as shown.

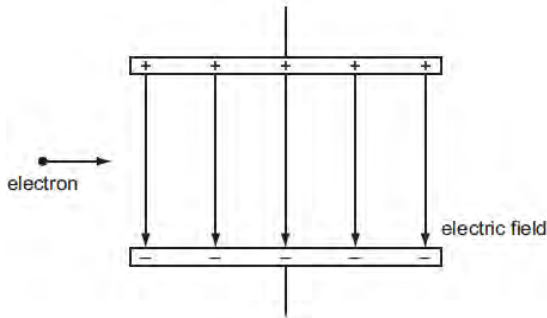

What are the horizontal and vertical components of the motion of this electron when it is in the field?

	horizontal component of motion	vertical component of motion
A	constant speed	acceleration upwards
B	constant speed	acceleration downwards
C	acceleration to the right	acceleration downwards
D	acceleration to the right	acceleration upwards

92. The electric field strength between a pair of parallel plates is E . The separation of the plates is doubled and the potential difference between the plates is increased by a factor of four. What is the new electric field strength?

- A E B $2E$ C $4E$ D $8E$

93. What is a correct statement of Ohm's law?

- A The potential difference across a component equals the current providing the resistance and other physical conditions stay constant.
- B The potential difference across a component equals the current multiplied by the resistance.
- C The potential difference across a component is proportional to its resistance.
- D The potential difference across a component is proportional to the current in it providing physical conditions stay constant.

94. The current in a resistor is $8.0\ \text{mA}$. What charge flows through the resistor in $0.020\ \text{s}$?
 A $0.16\ \text{mC}$ B $1.6\ \text{mC}$ C $4.0\ \text{mC}$ D $0.40\ \text{C}$

95. A cell of e.m.f. $2.0\ \text{V}$ and negligible internal resistance is connected to the network of resistors shown.

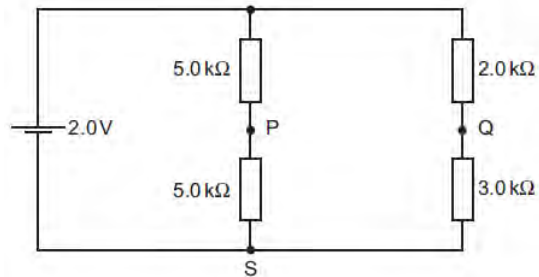

V_1 is the potential difference between S and P. V_2 is the potential difference between S and Q. What is the value of $V_1 - V_2$?
 A $+0.50\ \text{V}$ B $+0.20\ \text{V}$ C $-0.20\ \text{V}$ D $-0.50\ \text{V}$

96. A circuit is set up with an LDR and a fixed resistor as shown.

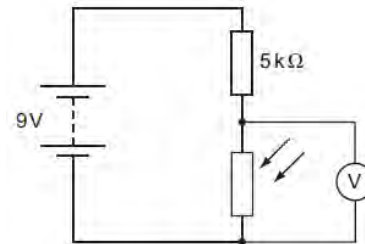

The voltmeter reads $4\ \text{V}$. The light intensity is increased. What is a possible voltmeter reading?

- A $3\ \text{V}$ B $4\ \text{V}$ C $6\ \text{V}$ D $8\ \text{V}$

97. In the circuit below, the battery converts an amount E of chemical energy to electrical energy when charge Q passes through the resistor in time t .

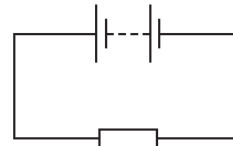

Which expressions give the e.m.f. of the battery and the current in the resistor?

	e.m.f.	current
A	EQ	Q/t
B	EQ	Qt
C	E/Q	Q/t
D	E/Q	Qt

98. A battery has an e.m.f. of $3.0\ \text{V}$ and an internal resistance of $2.0\ \Omega$.

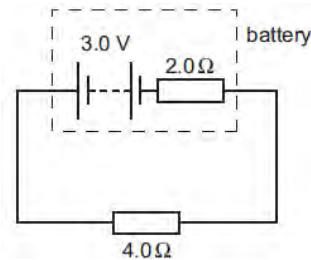

The battery is connected to a load of $4.0\ \Omega$. What are the terminal potential difference V and output power P ?

	V/V	P/W
A	1.0	0.50
B	1.0	1.5
C	2.0	1.0
D	2.0	1.5

99. A researcher has two pieces of copper of the same volume. All of the first piece is made into a cylindrical resistor P of length x .

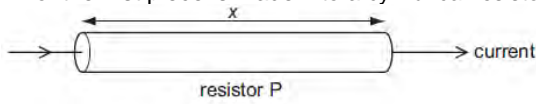

All of the second piece is made into uniform wires each of the same length x which he connects between two bars of negligible resistance to form a resistor Q.

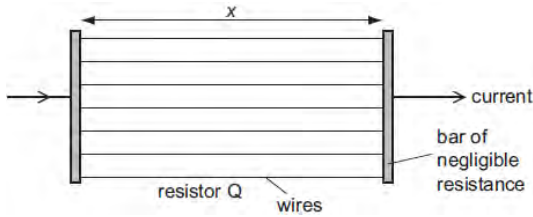

How do the electrical resistances of P and Q compare?

- A P has a larger resistance than Q.
- B Q has a larger resistance than P.
- C P and Q have equal resistance.
- D Q may have a larger or smaller resistance than P, depending on the number of wires made.

Nov 07

100. An electron is situated in a uniform electric field as shown in the diagram.

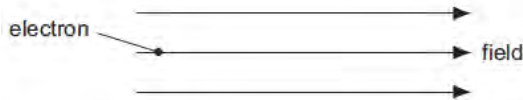

What is the direction of the electric force acting on the electron?
 A downwards into the paper B upwards out of the paper
 C to the left D to the right

101. Which diagram shows the electric field between a positively charged metal sphere and an earthed metal plate?

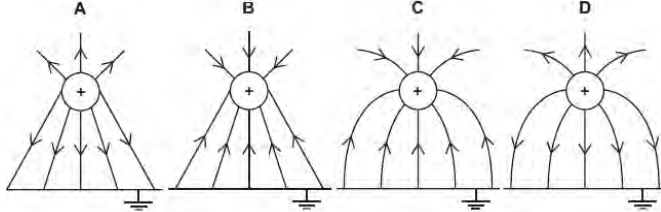

102. Which electrical quantity would be the result of a calculation in which energy transfer is divided by charge?
 A current B potential difference C power D resistance

103. Two heating coils X and Y, of resistance R_X and R_Y respectively, deliver the same power when 12 V is applied across X and 6 V is applied across Y. What is the ratio R_X / R_Y ?

- A $\frac{1}{4}$ B $\frac{1}{2}$ C 2 D 4

104. A battery of negligible internal resistance is connected to two 10Ω resistors in series.

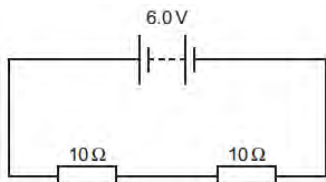

What charge flows through each of the 10Ω resistors in 1 minute?
 A 0.30 C B 0.60 C C 3.0 C D 18 C

105. Two wires P and Q have resistances R_P and R_Q respectively. Wire P is twice as long as wire Q and has twice the diameter of wire Q. The wires are made of the same material.

What is the ratio $\frac{R_P}{R_Q}$?

- A 0.5 B 1 C 2 D 4

106. A potential divider consists of a fixed resistor R and a light-dependent resistor (LDR).

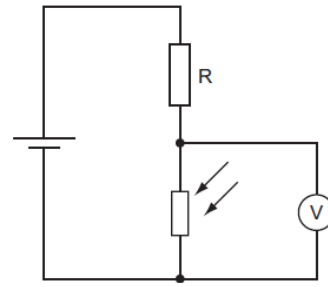

What happens to the voltmeter reading, and why does it happen, when the intensity of light on the LDR increases?

- A. The voltmeter reading decreases because the LDR resistance decreases.
- B The voltmeter reading decreases because the LDR resistance increases.
- C The voltmeter reading increases because the LDR resistance decreases.
- D The voltmeter reading increases because the LDR resistance increases.

107. The circuit is designed to trigger an alarm system when the input voltage exceeds some preset value. It does this by comparing V_{out} with a fixed reference voltage, which is set at 4.8 V.

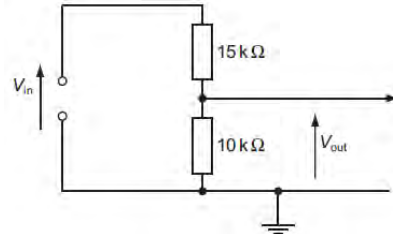

V_{out} is equal to 4.8 V. What is the input voltage V_{in} ?

- A 4.8 V B 7.2 V C 9.6 V D 12 V

108. A potentiometer is used as shown to compare the e.m.f.s of two cells.

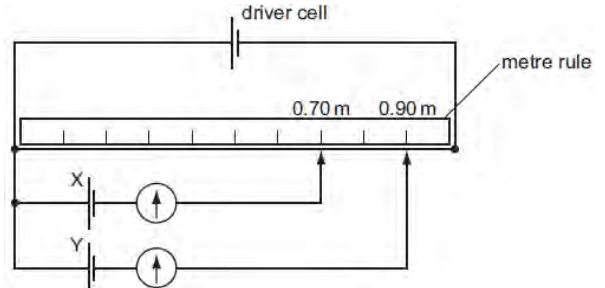

The balance points for cells X and Y are 0.70 m and 0.90 m respectively.

If the e.m.f. of cell X is 1.1 V, what is the e.m.f. of cell Y?

- A 0.69 V B 0.86 V C 0.99 V D 1.4 V

109. When four identical resistors are connected as shown in diagram 1, the ammeter reads 1.0 A and the voltmeter reads zero.

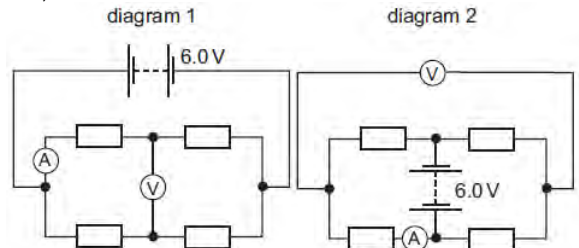

The resistors and meters are reconnected to the supply as shown in diagram 2. What are the meter readings in diagram 2?

	voltmeter reading / V	ammeter reading / A
A	0	1.0
B	3.0	0.5
C	3.0	1.0
D	6.0	0

June 08

110. An electron enters the space between two parallel charged plates with an initial velocity u .

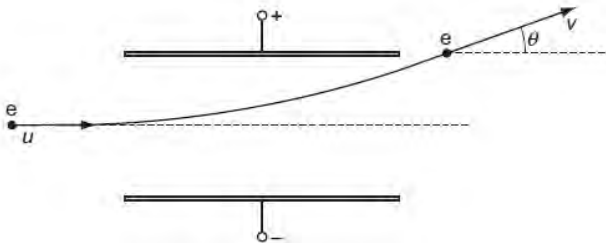

While in the electric field, its direction changes by θ and it emerges with a velocity v .
What is the relation between v and u ?

- A $v = \frac{u}{\cos \theta}$ B $v = u \cos \theta$ C $v = \frac{u}{\sin \theta}$ D $v = u \sin \theta$

111. The diagram shows an oil droplet that has become charged by gaining five electrons. The droplet remains stationary between charged plates.

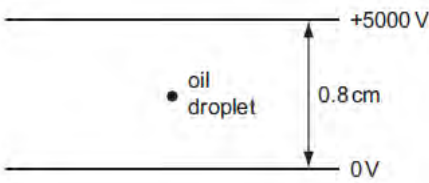

What is the magnitude and direction of the electrostatic force on the oil droplet?

- A 5.0×10^{-15} N upwards B 5.0×10^{-15} N downwards
C 5.0×10^{-13} N upwards D 5.0×10^{-13} N downwards

112. A power cable X has a resistance R and carries current I . A second cable Y has a resistance $2R$ and carries current $\frac{1}{2}I$.

What is the ratio $\frac{\text{power dissipated in Y}}{\text{power dissipated in X}}$?

- A. $\frac{1}{4}$ B. $\frac{1}{2}$ C. 2 D. 4

113. A total charge of 100 C flows through a 12 W light bulb in a time of 50 s.

What is the potential difference across the bulb during this time?
A 0.12 V B 2.0 V C 6.0 V D 24 V

114. Two copper wires X and Y have the same volume. Wire Y is four times as long as wire X.

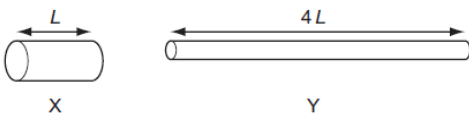

What is the ratio $\frac{\text{resistance of wire Y}}{\text{resistance of wire X}}$?

- A 4 B 8 C 16 D 64

115. The potential difference across a resistor is 12 V. The current in the resistor is 2.0 A. 4.0 C passes through the resistor. What is the energy transferred and the time taken?

	energy/J	time/s
A	3.0	2.0
B	3.0	8.0
C	48	2.0
D	48	8.0

116. A thermistor and another component are connected to a constant voltage supply. A voltmeter is connected across one of the components. The temperature of the thermistor is then reduced but no other changes are made.

In which circuit will the voltmeter reading increase?

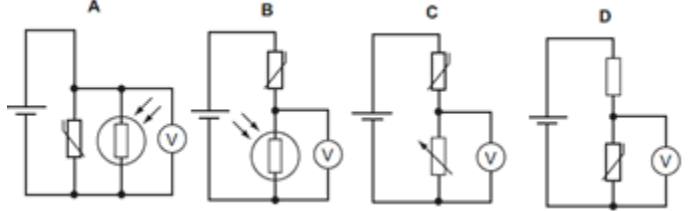

117. In the circuit shown, the 6.0 V battery has negligible internal resistance. Resistors R_1 and R_2 and the voltmeter have resistance 100 k Ω .

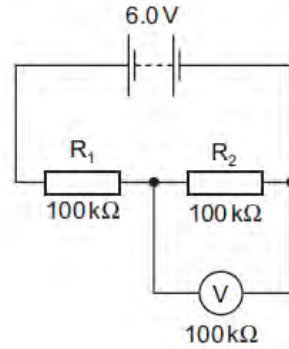

What is the current in the resistor R_2 ?
A 20 μ A B 30 μ A C 40 μ A D 60 μ A

118. The unknown e.m.f. E of a cell is to be determined using a potentiometer circuit. The balance length is to be measured when the galvanometer records a null reading.

What is the correct circuit to use?

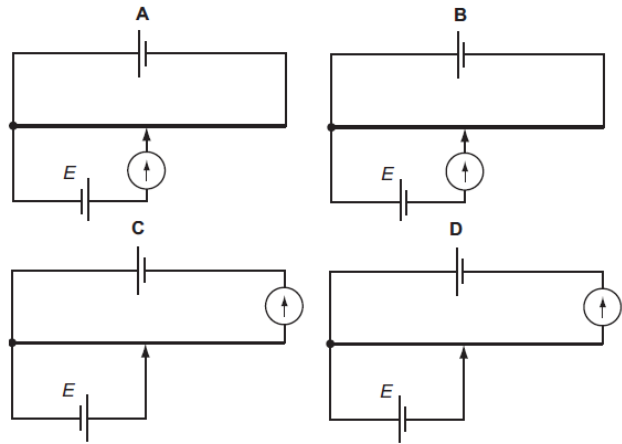

Nov 08

119. The diagram shows the electric field near a point charge and two electrons X and Y.

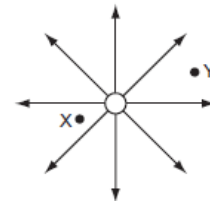

Which row describes the forces acting on X and Y?
direction of force magnitude of force on X

	direction of force	magnitude of force on X
A	radially inwards	less than force on Y
B	radially inwards	greater than force on Y
C	radially outwards	less than force on Y
D	radially outwards	greater than force on Y

120. A particle has a charge of $4.8 \times 10^{-19} \text{ C}$. The particle remains at rest between a pair of horizontal, parallel plates having a separation of 15 mm. The potential difference between the plates is 660 V.

What is the weight of the particle?
 A $2.1 \times 10^{-14} \text{ N}$ B $2.1 \times 10^{-15} \text{ N}$
 C $2.1 \times 10^{-17} \text{ N}$ D $1.1 \times 10^{-23} \text{ N}$

121. Two wires P and Q made of the same material and of the same length are connected in parallel to the same voltage supply. Wire P has diameter 2 mm and wire Q has diameter 1 mm.

What is the ratio $\frac{\text{current in P}}{\text{current in Q}}$?

A $\frac{1}{4}$ B $\frac{1}{2}$ C $\frac{2}{1}$ D $\frac{4}{1}$

122. An electric power cable consists of six copper wires c surrounding a steel core s.

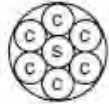

1.0 km of one of the copper wires has a resistance of 10Ω and 1.0 km of the steel core has a resistance of 100Ω .

What is the approximate resistance of a 1.0 km length of the power cable?

A 0.61Ω B 1.6Ω C 160Ω D 610Ω

123. Which graph best represents the way the current I through a filament lamp varies with the potential difference V across it?

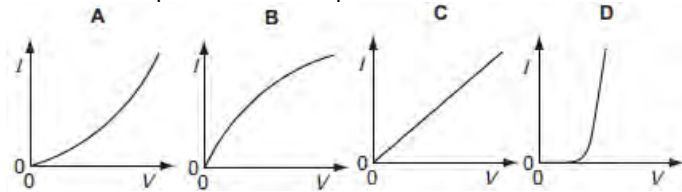

124. The charge that a fully-charged 12 V car battery can supply is 100 kC. The starter motor of the car requires a current of 200 A for an average period of 2.0 s. The battery does not recharge because of a fault.

What is the maximum number of times the starter motor of the car can be used?

A 21 B 25 C 42 D 250

125. The diagram shows a circuit containing three resistors in parallel.

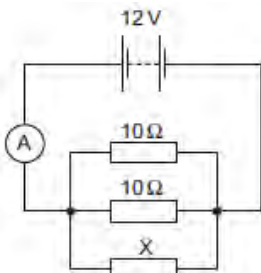

The battery has e.m.f. 12 V and negligible internal resistance.

The ammeter reading is 3.2 A. What is the resistance of X?

A 2.1Ω B 4.6Ω C 6.0Ω D 15Ω

126. The e.m.f. of the battery is 9.0 V. The reading on the high-resistance voltmeter is 7.5 V.

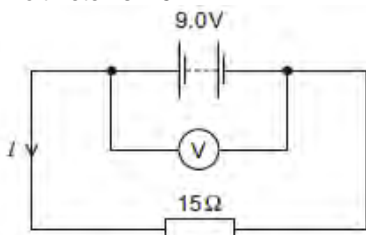

What is the current I ?

A 0.10 A B 0.50 A C 0.60 A D 2.0 A

127. The diagram shows a potentiometer circuit.

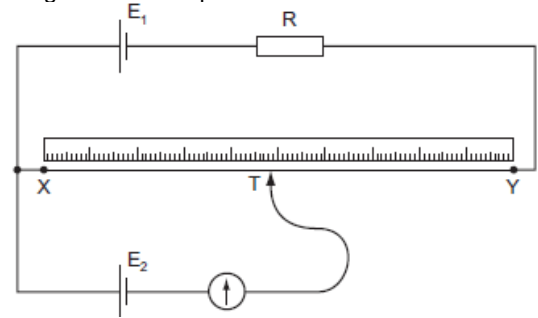

The contact T is placed on the wire and moved along the wire until the galvanometer reading is zero. The length XT is then noted.

In order to calculate the potential difference per unit length on the wire XY, which value must also be known?

A the e.m.f. of the cell E_1 B the e.m.f. of the cell E_2
 C the resistance of resistor R D the resistance of the wire XY

June 09

128. The diagram shows the paths of two charged particles, X and Y, during their passage between a pair of oppositely charged metal plates, P and Q.

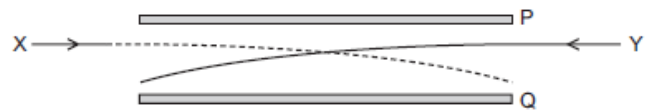

The plates are charged such that the electric field between them is directed from Q to P.

Which charges on X and Y will produce the observed paths?

	X	Y
A	-	-
B	-	+
C	+	-
D	+	+

129. There is a potential difference between a pair of parallel plates. Which values of potential difference and separation of the plates will produce an electric field strength of the greatest value?

	potential difference	separation
A	2V	2d
B	2V	$\frac{d}{2}$
C	$\frac{V}{2}$	2d
D	$\frac{V}{2}$	$\frac{d}{2}$

130. The diagram shows an electron, with charge e , mass m , and velocity v , entering a uniform electric field of strength E .

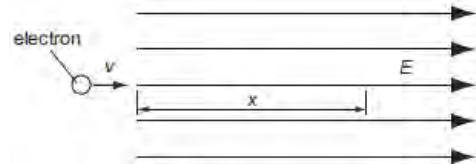

The direction of the field and the electron's motion are both horizontal and to the right. Which expression gives the distance x through which the electron travels before it stops momentarily?

A $x = \frac{mv}{E}$ B $x = \frac{mv}{Ee}$ C $x = \frac{mv^2}{2E}$ D $x = \frac{mv^2}{2Ee}$

131. Which amount of charge, flowing in the given time, will produce the largest current?

	charge / C	time / s
A	4	$\frac{1}{4}$
B	4	1
C	1	4
D	$\frac{1}{4}$	4

132. A 12 V battery is charged for 20 minutes by connecting it to a source of electromotive force (e.m.f.). The battery is supplied with 7.2×10^4 J of energy in this time.

How much charge flows into the battery?

- A 5.0 C B 60 C C 100 C D 6000 C

133. What is meant by the electromotive force (e.m.f.) of a cell?

- A The e.m.f. of a cell is the energy converted into electrical energy when unit charge passes through the cell.
 B The e.m.f. of a cell is the energy transferred by the cell in driving unit charge through the external resistance.
 C The e.m.f. of a cell is the energy transferred by the cell in driving unit charge through the internal resistance of the cell.
 D The e.m.f. of a cell is the amount of energy needed to bring a unit positive charge from infinity to its positive pole.

134. Two cells of e.m.f. 3.0 V and 1.2 V and negligible internal resistance are connected to resistors of resistance 9.0Ω and 18Ω as shown.

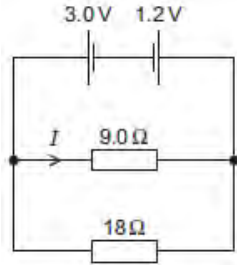

What is the value of the current I in the 9.0Ω resistor?

- A 0.10 A B 0.20 A C 0.30 A D 0.47 A

135. Six identical 12Ω resistors are arranged in two groups, one with three in series and the other with three in parallel.

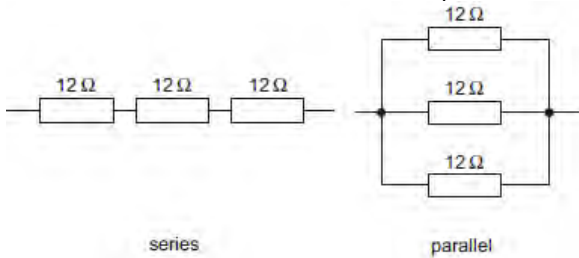

What are the combined resistances of each of these two arrangements?

	series	parallel
A	4.0Ω	0.25Ω
B	4.0Ω	36Ω
C	36Ω	0.25Ω
D	36Ω	4.0Ω

136. The diagrams show a light-dependent resistor in circuit P, and a thermistor in circuit Q.

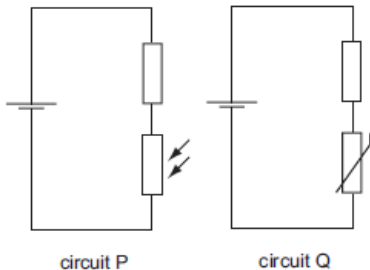

How does the potential difference across the fixed resistor in each circuit change when both the brightness of the light on the light-dependent resistor and the temperature of the thermistor are increased?

	circuit P	circuit Q
A	decrease	decrease
B	decrease	increase
C	increase	decrease
D	increase	increase

Nov 09

137. A small charge q is placed in the electric field of a large charge Q . Both charges experience a force F .

What is the electric field strength of the charge Q at the position of the charge q ?

- A $\frac{F}{Qq}$ B $\frac{F}{Q}$ C FqQ D $\frac{F}{q}$

138. The diagram shows two parallel horizontal metal plates held at a potential difference V .

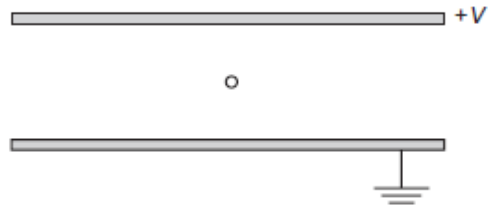

A small charged liquid drop, midway between the plates, is held in equilibrium by the combination of its weight and the electric force acting on it. The acceleration of free fall is g and the electric field strength is E .

What is the ratio of the charge to mass of the drop, and the polarity of the charge on the drop?

	charge mass	polarity
A	$\frac{q}{E}$	positive
B	$\frac{q}{E}$	negative
C	$\frac{E}{g}$	positive
D	$\frac{E}{g}$	negative

139. The electric field at a certain distance from an isolated alpha particle is $3.0 \times 10^7 \text{ N C}^{-1}$.

What is the force on an electron when at that distance from the alpha particle?

- A $4.8 \times 10^{-12} \text{ N}$ B $9.6 \times 10^{-12} \text{ N}$
 C $3.0 \times 10^7 \text{ N}$ D $6.0 \times 10^7 \text{ N}$

140. A cell is connected to a resistor.

At any given moment, the potential difference across the cell is less than its electromotive force.

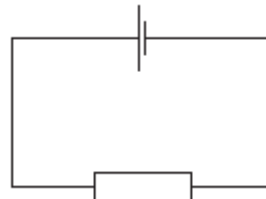

Which statement explains this?

- A The cell is continually discharging.
 B The connecting wire has some resistance.
 C Energy is needed to drive charge through the cell.
 D Power is used when there is a current in the resistor.

141. Which values of current and resistance will produce a rate of energy transfer of 16 J s^{-1} ?

	current / A	resistance / Ω
A	1	4
B	2	8
C	4	1
D	16	1

142. A cylindrical wire 4.0 m long has a resistance of 31Ω and is made of metal of resistivity $1.0 \times 10^{-6} \Omega \text{ m}$.

What is the radius of cross-section of the wire?

- A $1.0 \times 10^{-8} \text{ m}$ B $2.0 \times 10^{-8} \text{ m}$
 C $6.4 \times 10^{-8} \text{ m}$ D $2.0 \times 10^{-4} \text{ m}$

143. Each of Kirchhoff's two laws presumes that some quantity is conserved.

Which row states Kirchhoff's first law and names the quantity that is conserved?

	statement	quantity
A	the algebraic sum of currents into a junction is zero	charge
B	the algebraic sum of currents into a junction is zero	energy
C	the e.m.f. in a loop is equal to the algebraic sum of the product of current and resistance round the loop	charge
D	the e.m.f. in a loop is equal to the algebraic sum of the product of current and resistance round the loop	energy

144. The diagram shows the symbol for a wire carrying a current I .

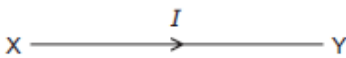

What does this current represent?

- A the amount of charge flowing past a point in XY per second
- B the number of electrons flowing past a point in XY per second
- C the number of positive ions flowing past a point in XY per second
- D the number of protons flowing past a point in XY per second

145. A potential divider consisting of resistors of resistance R_1 and R_2 is connected to an input potential difference of V_0 and gives an output p.d. of V .

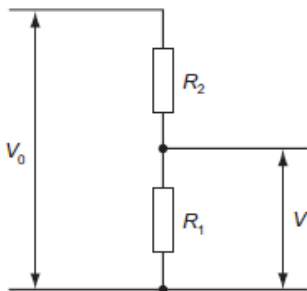

What is the value of V ?

- A $\frac{V_0 R_1}{R_2}$
- B $\frac{V_0 R_1}{R_1 + R_2}$
- C $\frac{V_0 R_2}{R_1 + R_2}$
- D $\frac{V_0 (R_1 + R_2)}{R_1}$

146. A network of resistors consists of two 3.0Ω resistors and three 6.0Ω resistors.

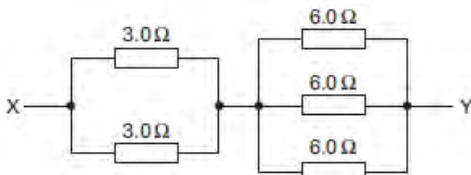

What is the combined resistance of this network between points X and Y?

- A 0.86Ω
- B 1.2Ω
- C 3.5Ω
- D 24Ω

June 10

147. Which row describes the circumstances under which forces act on a charged particle in a uniform electric field?

	charged particle	direction of force
A	moving charges only	parallel to the field
B	stationary charges only	perpendicular to the field
C	stationary and moving charges	parallel to the field
D	stationary and moving charges	perpendicular to the field

148. The diagram shows two points P and Q which lie, 90° apart, on a circle of radius r .

A positive point charge at the centre of the circle creates an electric field of magnitude E at both P and Q.

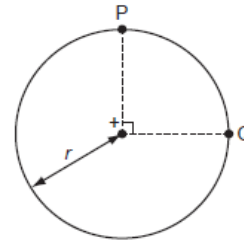

Which expression gives the work done in moving a unit positive charge from P to Q?

- A 0
- B $E \times r$
- C $E \times \left(\frac{\pi r}{2}\right)$
- D $E \times (\pi r)$

149. Two oppositely-charged parallel plates are arranged as shown.

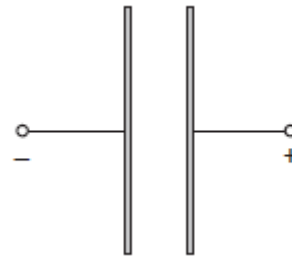

An electron is released from rest from the surface of the negatively-charged plate.

The electron travels from the negatively-charged plate towards the positively-charged plate.

Which graph shows how the force F on the electron varies with its distance x from the negative plate?

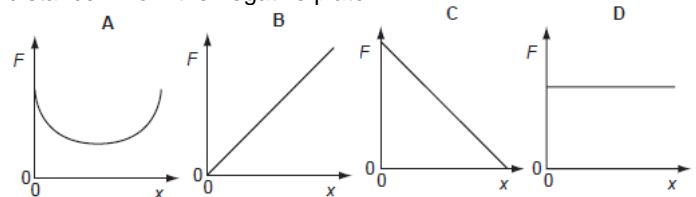

150. In the diagram, the shaded area represents a uniform electric field directed away from the observer (at right-angles into the plane of the paper).

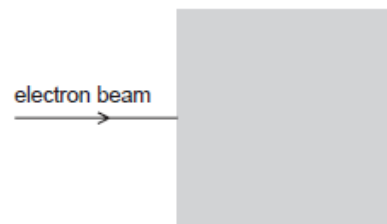

A horizontal beam of electrons enters the field, travelling from left to right.

In which direction is this beam deflected by the field?

- A upwards (in the plane of the paper)
- B downwards (in the plane of the paper)
- C away from the observer
- D towards the observer

151. In terms of energy transfer W and charge q , what are the definitions of potential difference (p.d.) and electromotive force (e.m.f.)?

	p.d.	e.m.f.
A	$\frac{W}{q}$	$\frac{W}{q}$
B	$\frac{W}{q}$	Wq
C	Wq	$\frac{W}{q}$
D	Wq	Wq

152. The resistance of a thermistor depends on its temperature, and the resistance of a light-dependent resistor (LDR) depends on the illumination.

Under which conditions will the resistance of both a thermistor and an LDR be highest?

	thermistor	LDR
A	highest temperature	highest illumination
B	highest temperature	lowest illumination
C	lowest temperature	highest illumination
D	lowest temperature	lowest illumination

153. The resistors P, Q and R in the circuit have equal resistance.

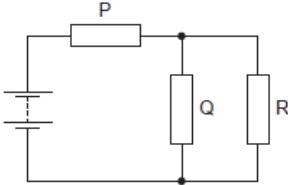

The battery, of negligible internal resistance, supplies a total power of 12 W.

What is the power dissipated by heating in resistor R?

- A 2 W B 3 W C 4 W D 6 W

154. In deriving a formula for the combined resistance of three different resistors in series, Kirchhoff's laws are used.

Which physics principle is involved in this derivation?

- A the conservation of charge
 B the direction of the flow of charge is from negative to positive
 C the potential difference across each resistor is the same
 D the current varies in each resistor, in proportion to the resistor value

155. What is the unit of resistivity?

- A $\Omega \text{ m}^{-2}$ B $\Omega \text{ m}^{-1}$ C Ω D $\Omega \text{ m}$

Answers:

1 b	27 d	53 a	79 c	105 a	131 a
2 c	28 a	54 d	80 b	106 a	132 d
3 a	29 a	55 c	81 c	107 d	133 a
4 c	30 c	56 c	82 c	108 d	134 b
5 a	31 b	57 d	83 a	109 a	135 d
6 c	32 d	58 d	84 d	110 a	136 d
7 c	33 b	59 b	85 a	111 d	137 d
8 a	34 d	60 d	86 a	112 b	138 b
9 b	35 d	61 b	87 d	113 c	139 a
10 d	36 a	62 a	88 b	114 c	140 c
11 a	37 d	63 a	89 b	115 c	141 c
12 a	38 b	64 d	90 d	116 d	142 d
13 c	39 c	65 a	91 a	117 a	143 a
14 d	40 a	66 b	92 b	118 b	144 a
15 a	41 d	67 d	93 d	119 b	145 b
16 b	42 b	68 c	94 a	120 a	146 c
17 b	43 d	69 b	95 c	121 d	147 c
18 c	44 b	70 b	96 a	122 b	148 a
19 a	45 a	71 c	97 c	123 b	149 d
20 b	46 d	72 b	98 c	124 d	150 d
21 b	47 c	73 a	99 c	125 d	151 a
22 b	48 b	74 c	100 c	126 b	152 d
23 c	49 c	75 b	101 d	127 b	153 a
24 d	50 c	76 b	102 b	128 a	154 a
25 b	51 d	77 a	103 d	129 b	155 d
26 b	52 b	78 b	104 d	130 d	