

Q1.When fully charged the 2.0 mF capacitor used as a backup for a memory unit has a potential difference of 5.0 V across it. The capacitor is required to supply a constant current of 1.0 μA and can be used until the potential difference across it falls by 10%. For how long can the capacitor be used before it must be recharged?

- A 10 s
- B 100 s
- C 200 s
- D 1000 s

(Total 1 mark)

Q2.A capacitor of capacitance 10 μF is charged through a resistor **R** to a potential difference (pd) of 20 V using the circuit shown.

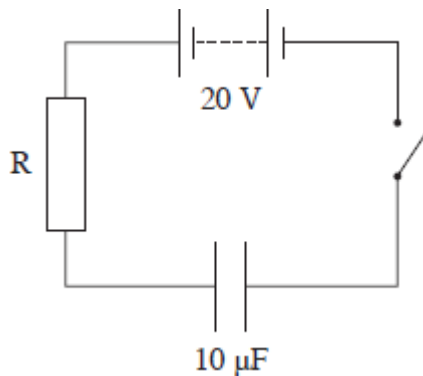

When the capacitor is fully charged which one of the following statements is **incorrect**?

- A The energy stored by the capacitor is 2 mJ.
- B The total energy taken from the battery during the charging process is 2 mJ.
- C The pd across the capacitor is 20 V.
- D The pd across the resistor is 0 V.

(Total 1 mark)

Q3.The diagram shows a rigidly-clamped straight horizontal current-carrying wire held mid-way between the poles of a magnet on a top-pan balance. The wire is perpendicular to the magnetic field direction.

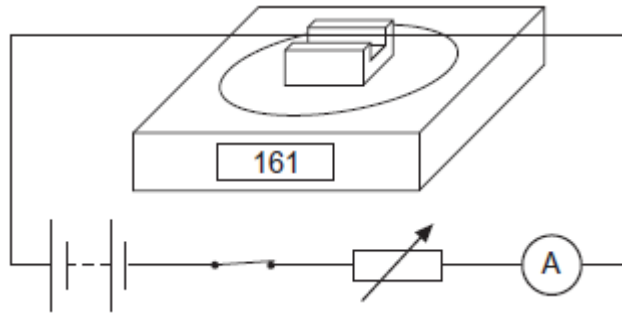

The balance, which was zeroed before the switch was closed, read 161 g after the switch was closed. When the current is reversed and doubled, what would be the new reading on the balance?

- A -322 g
- B -161 g
- C zero
- D 322 g

(Total 1 mark)

Q4.(a) The graph shows how the current varies with time as a capacitor is discharged through a 150Ω resistor.

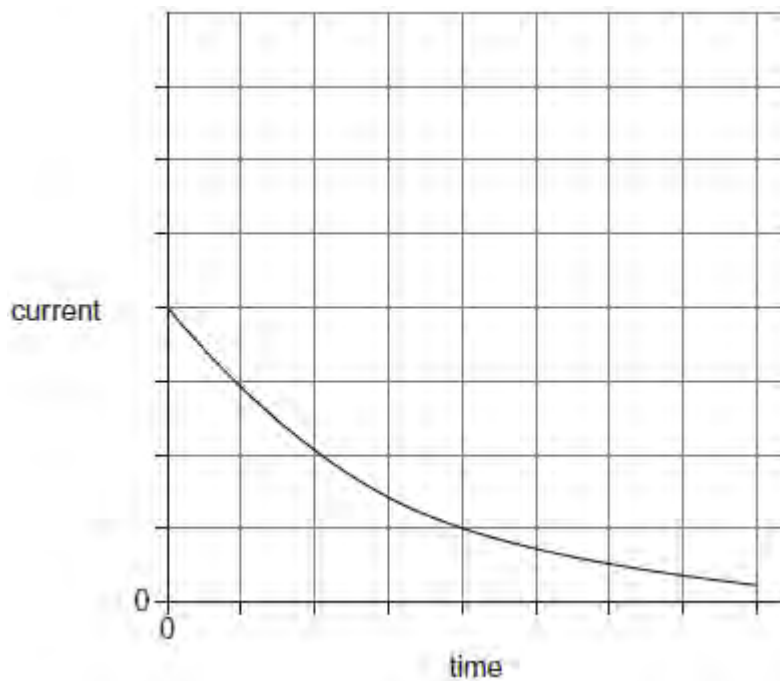

- (i) Explain how the initial charge on the capacitor could be determined from a

graph of current against time.

.....
.....
.....
.....

(1)

(ii) The same capacitor is charged to the same initial potential difference (pd) and then discharged through a 300 kΩ resistor. Sketch a second graph on the same axes above to show how the current varies with time in this case.

(3)

(b) In an experiment to show that a capacitor stores energy, a student charges a capacitor from a battery and then discharges it through a small electric motor. The motor is used to lift a mass vertically.

(i) The capacitance of the capacitor is 0.12 F and it is charged to a pd of 9.0 V. The weight of the mass raised is 3.5 N. Calculate the maximum height to which the mass could be raised. Give your answer to an appropriate number of significant figures.

maximum height m

(4)

(ii) Give **two** reasons why the value you have calculated in part (i) would not be achieved in practice.

1

.....

.....

.....

2

.....

.....

.....

(2)
(Total 10 marks)

Q5. The specification for a pacemaker requires a suitable charge to be delivered in 1.4 ms. A designer uses a circuit with a capacitor of capacitance $3.0 \mu\text{F}$ and a 2.5 V power supply to deliver the charge. The designer calculates that a suitable charge will be delivered to the heart as the capacitor discharges from a potential difference (pd) of 2.5 V to a pd of 1.2 V in 1.4 ms.

(a) (i) Calculate the charge on the capacitor when it is charged to a pd of 2.5 V.

charge C

(1)

(ii) Draw a graph showing how the charge, Q , on the capacitor varies with the pd, V , as it discharges through the heart. Include an appropriate scale on the charge axis.

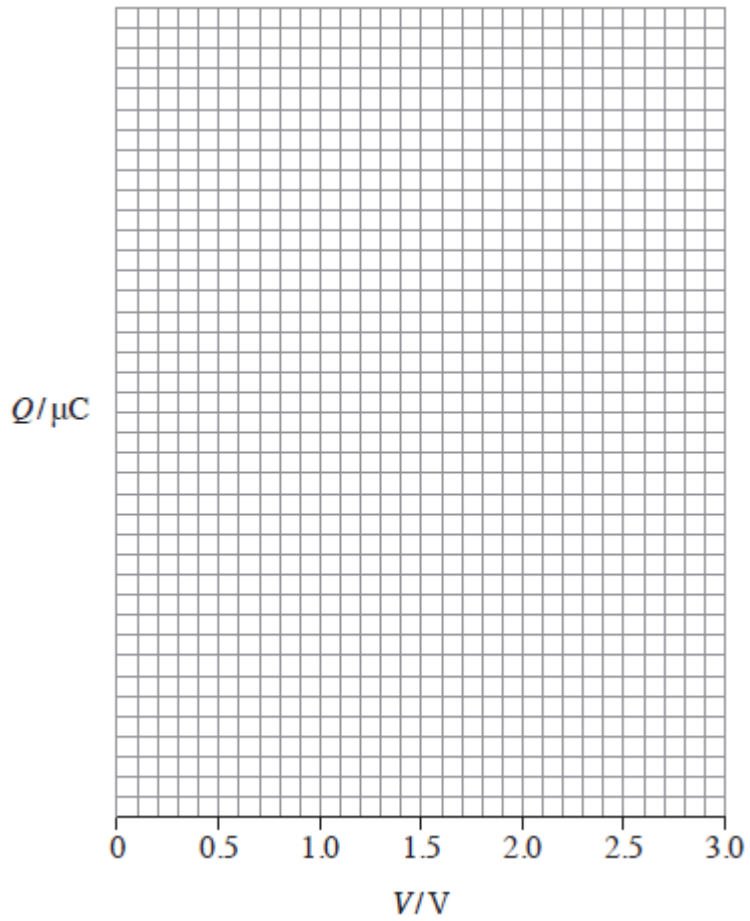

(3)

- (b) Calculate the energy delivered to the heart in a single pulse from the pacemaker when the capacitor discharges to 1.2 V from 2.5 V.

energy J

(3)

- (c) (i) Calculate the resistance of the heart that has been assumed in the design.

resistance Ω

(3)

- (ii) Explain why the rate of change of pd between the capacitor plates decreases as the capacitor discharges.

.....
.....
.....
.....
.....

(2)

(Total 12 marks)

Q6. The figure below shows a capacitor of capacitance 370 pF. It consists of two parallel metal plates of area 250 cm². A sheet of polythene that has a relative permittivity 2.3 completely fills the gap between the plates.

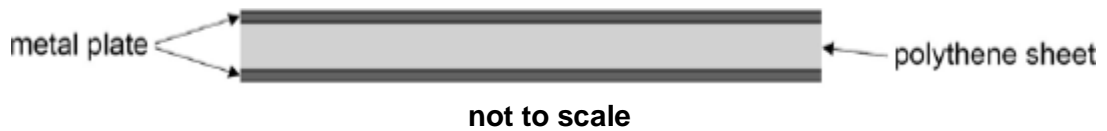

- (a) Calculate the thickness of the polythene sheet.

thickness = _____ m

(2)

- (b) The capacitor is charged so that there is a potential difference of 35 V between the plates. The charge on the capacitor is then 13 nC and the energy stored is 0.23 μ J.

The supply is now disconnected and the polythene sheet is pulled out from between the plates without discharging or altering the separation of the plates.

Show that the potential difference between the plates increases to about 80 V.

(2)

(c) Calculate the energy that is now stored by the capacitor.

energy stored = _____ μJ

(2)

(d) Explain why there is an increase in the energy stored by the capacitor when the polythene sheet is pulled out from between the plates.

.....
.....
.....
.....

(2)

(Total 8 marks)

Q7. Which of the following statements about a parallel plate capacitor is **incorrect**?

A The capacitance of the capacitor is the amount of charge stored by the capacitor when the pd across the plates is 1 V.

B A uniform electric field exists between the plates of the capacitor.

C The charge stored on the capacitor is inversely proportional to the pd across the plates.

- D The energy stored when the capacitor is fully charged is proportional to the square of the pd across the plates.



(Total 1 mark)

Q8. Initially a charged capacitor stores $1600 \mu\text{J}$ of energy. When the pd across it decreases by 2.0 V , the energy stored by it becomes $400 \mu\text{J}$.

What is the capacitance of this capacitor?

- A $100 \mu\text{F}$
- B $200 \mu\text{F}$
- C $400 \mu\text{F}$
- D $600 \mu\text{F}$

(Total 1 mark)

Q9. Switch S in the circuit is held in position 1, so that the capacitor C becomes fully charged to a pd V and stores energy E .

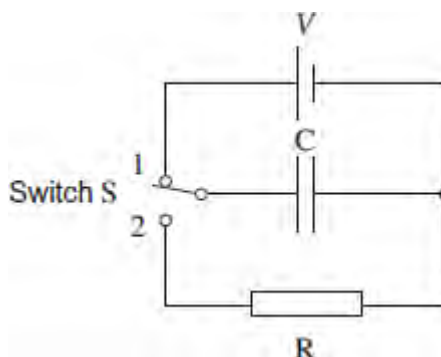

The switch is then moved quickly to position 2, allowing C to discharge through the fixed resistor R . It takes 36 ms for the pd across C to fall to $\frac{V}{2}$. What period of time must elapse, after the switch has moved to position 2, before the energy stored by C has fallen to $\frac{E}{16}$?

- A 51 ms
- B 72 ms
- C 432 ms

D 576 ms

(Total 1 mark)

Q10. A nuclear fusion device is required to deliver at least 1 MJ of energy using capacitors. If the largest workable potential difference is 10 kV, what is the minimum capacitance of the capacitors that should be used?

- A 0.01 F
- B 0.02 F
- C 2 F
- D 100 F

(Total 1 mark)

Q11. An initially uncharged capacitor of capacitance 20 μF is charged by a constant current of 80 μA . Which line, **A** to **D**, in the table gives the potential difference across, and the energy stored in, the capacitor after 50 s?

	potential difference / V	energy stored / J
A	4.0×10^{-3}	2.0×10^{-3}
B	4.0×10^{-3}	4.0×10^{-1}
C	2.0×10^2	2.0×10^{-3}
D	2.0×10^2	4.0×10^{-1}

(Total 1 mark)

Q12. Which one of the following statements about a parallel plate capacitor is **incorrect**?

- A The capacitance of the capacitor is the amount of charge stored by the capacitor when the pd across the plates is 1V.
- B A uniform electric field exists between the plates of the capacitor.
- C The charge stored on the capacitor is inversely proportional to the pd across the plates.

- D The energy stored when the capacitor is fully charged is proportional to the square of the pd across the plates.

(Total 1 mark)

- Q13. The graph shows the results of an experiment which was carried out to investigate the relationship between the charge Q stored by a capacitor and the pd V across it.

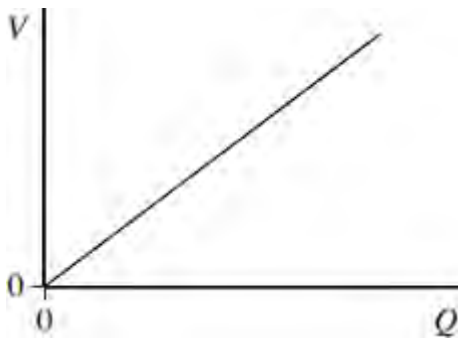

Which one of the following statements is **not** correct?

- A The energy stored can be calculated by finding the area under the line.
- B If a capacitor of smaller capacitance had been used the gradient of the graph would be steeper.
- C If Q were doubled, the energy stored would be quadrupled.
- D The gradient of the graph is equal to the capacitance of the capacitor.

(Total 1 mark)

- Q14. A $10\ \mu\text{F}$ capacitor is fully charged to a pd of $3.0\ \text{kV}$. The energy stored in the capacitor can be used to lift a load of $5.0\ \text{kg}$ through a vertical height h . What is the approximate value of h ?

- A $0.03\ \text{mm}$
- B $0.9\ \text{mm}$
- C $0.3\ \text{m}$
- D $0.9\ \text{m}$

(Total 1 mark)

Q15. A $400 \mu\text{F}$ capacitor is charged so that the voltage across its plates rises at a constant rate from 0 V to 4.0 V in 20 s . What current is being used to charge the capacitor?

- A** $5 \mu\text{A}$
- B** $20 \mu\text{A}$
- C** $40 \mu\text{A}$
- D** $80 \mu\text{A}$

(Total 1 mark)

Q16. A capacitor of capacitance C stores an amount of energy E when the pd across it is V . Which line, **A** to **D**, in the table gives the correct stored energy and pd when the charge is increased by 50% ?

	energy	pd
A	$1.5 E$	$1.5 V$
B	$1.5 E$	$2.25 V$
C	$2.25 E$	$1.5 V$
D	$2.25 E$	$2.25 V$

(Total 1 mark)