

Thursday 13 June 2013 – Afternoon

**A2 GCE PHYSICS A**

**G485/01** Fields, Particles and Frontiers of Physics

Candidates answer on the Question Paper.

**OCR supplied materials:**

- Data, Formulae and Relationships Booklet (sent with general stationery)

**Other materials required:**

- Electronic calculator

**Duration:** 2 hours



Candidate forename		Candidate surname	
--------------------	--	-------------------	--

Centre number						Candidate number				
---------------	--	--	--	--	--	------------------	--	--	--	--

**INSTRUCTIONS TO CANDIDATES**

- Write your name, centre number and candidate number in the boxes above. Please write clearly and in capital letters.
- Use black ink. HB pencil may be used for graphs and diagrams only.
- Answer **all** the questions.
- Read each question carefully. Make sure you know what you have to do before starting your answer.
- Write your answer to each question in the space provided. If additional space is required, you should use the lined page(s) at the end of this booklet. The question number(s) must be clearly shown.
- Do **not** write in the bar codes.

**INFORMATION FOR CANDIDATES**

- The number of marks is given in brackets [ ] at the end of each question or part question.
- The total number of marks for this paper is **100**.
- You are advised to show all the steps in any calculations.



Where you see this icon you will be awarded marks for the quality of written communication in your answer.

This means, for example, you should:

- ensure that text is legible and that spelling, punctuation and grammar are accurate so that meaning is clear;
- organise information clearly and coherently, using specialist vocabulary when appropriate.
- You may use an electronic calculator.
- This document consists of **24** pages. Any blank pages are indicated.

2

Answer **all** the questions.

- 1 (a) Fig. 1.1 shows an arrangement of capacitors.

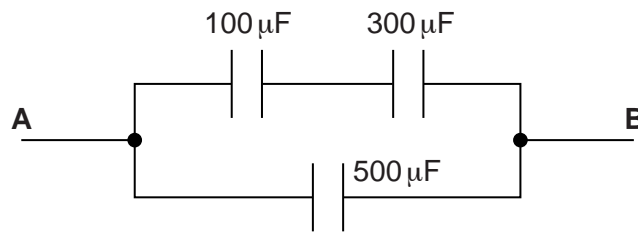
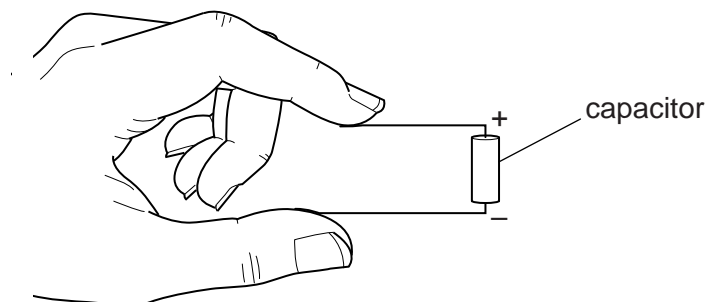

**Fig. 1.1**

Determine the total capacitance between **A** and **B**.

capacitance = .....  $\mu\text{F}$  [2]

- (b) A capacitor of capacitance  $500\ \mu\text{F}$  is charged to  $6.0\text{V}$ . A student places her thumb and first finger across the terminals of the capacitor as shown in Fig. 1.2. This provides a high resistance path across the terminals of the capacitor causing it to discharge.



**Fig. 1.2**

Fig. 1.3 shows the variation of potential difference  $V$  across the capacitor with time  $t$ .

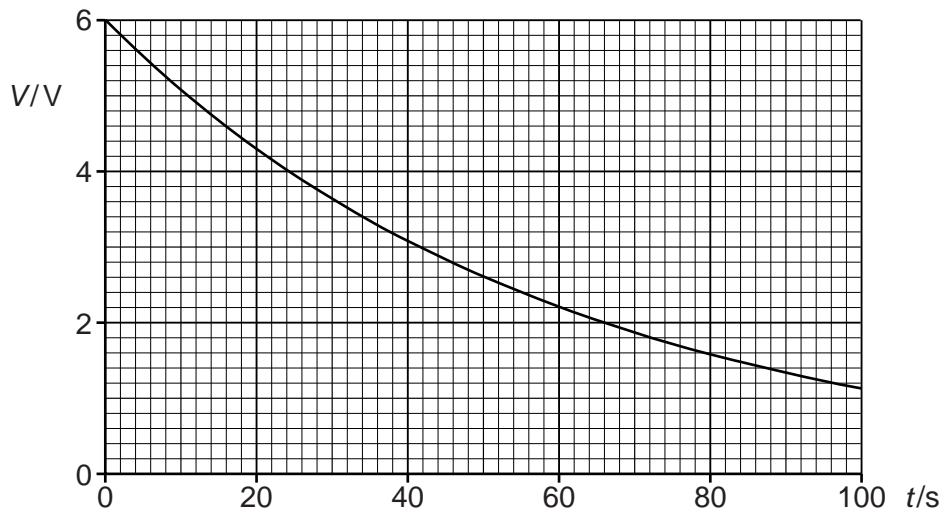

**Fig. 1.3**

- (i) Use Fig. 1.3 to calculate the resistance across the terminals of the capacitor.

resistance = .....  $\Omega$  [3]

- (ii) Calculate the energy lost by the capacitor from time  $t = 0$  to  $t = 30$  s.

energy lost = ..... J [3]

[Total: 8]

4

- 2 Fig. 2.1 shows two identical negatively charged conducting spheres.

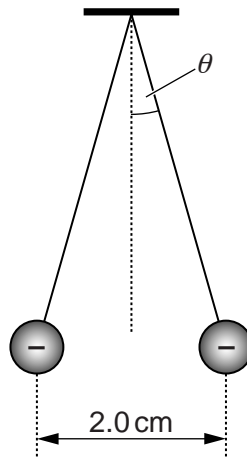

**Fig. 2.1**

The spheres are tiny and each is suspended from a nylon thread. Each sphere has mass  $6.5 \times 10^{-5} \text{ kg}$  and charge  $-2.8 \times 10^{-9} \text{ C}$ . The separation between the centres of the spheres is 2.0 cm.

- (a) Calculate the number of excess electrons on the surface of each sphere.

number = ..... [1]

- (b) Calculate the repulsive electrical force acting on each sphere.

force = ..... N [2]

5

- (c) (i) Each sphere is in equilibrium and experiences three forces. One of the forces acting on each sphere is the electrical force. State the other **two** forces acting on each sphere.

.....  
..... [1]

- (ii) Use your knowledge of vectors to determine the angle  $\theta$  made by each thread with the vertical.

$\theta = \dots\dots\dots^\circ$  [3]

[Total: 7]

6

- 3 Fig. 3.1 shows an arrangement used to accelerate electrons.

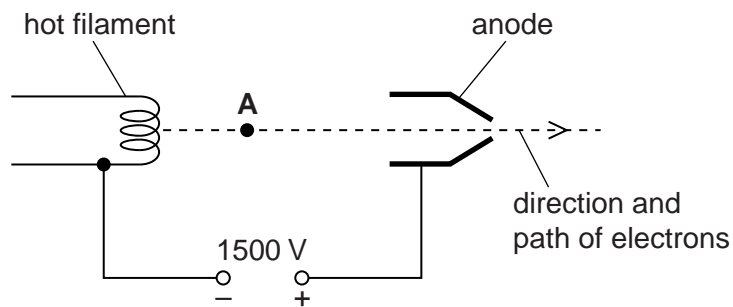

Fig. 3.1

- (a) Draw an arrow on Fig. 3.1 to show the direction of the electric field at point A. [1]
- (b) The potential difference between the filament and the anode is 1500V. The speed of an electron at the filament is negligible.
- (i) Determine the kinetic energy in electronvolts (eV) of an electron at the anode.

kinetic energy = ..... eV [1]

- (ii) Calculate the speed  $v$  of an electron at the anode.

$v = \dots\dots\dots \text{ms}^{-1}$  [3]

- (c) The electrons from the arrangement shown in Fig. 3.1 enter a region of space occupied by both uniform electric and magnetic fields, as shown in Fig. 3.2.

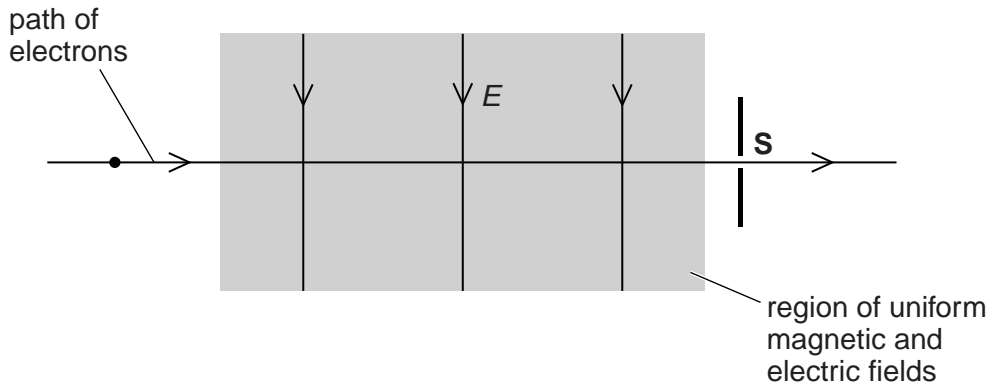

Fig. 3.2

The electric field strength of the electric field is  $E$  and its direction is shown in Fig. 3.2. The magnetic flux density of the magnetic field is  $B$ . The direction of the magnetic field is perpendicular to  $E$  and directed into the plane of the paper.  $B$  is increased until all the electrons pass through the slit **S** at a particular speed  $v$ . The path of the electrons is now horizontal as shown.

- (i) Derive an expression for  $v$  in terms of  $E$  and  $B$ .

[2]

- (ii) The magnetic flux density is increased further. The electric field strength is unchanged. Describe and explain what happens to the path of the electrons.

.....

.....

.....

..... [2]

[Total: 9]

4 (a) Define *magnetic flux*.

.....

.....

..... [1]

(b) Fig. 4.1 shows a solenoid connected to a battery and the magnetic field through it when the switch **S** is closed.

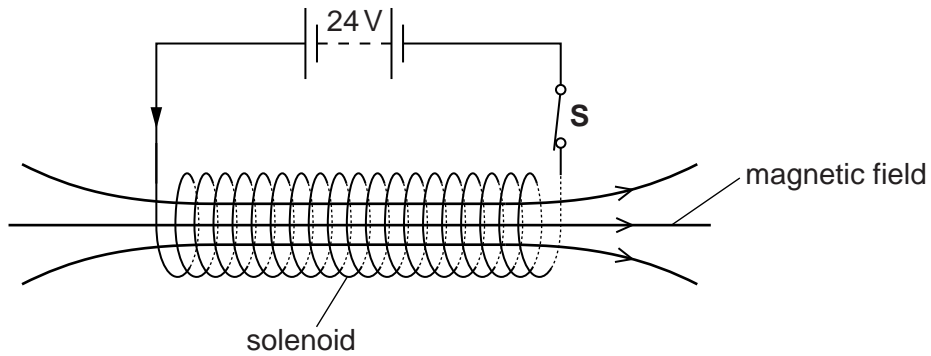

**Fig. 4.1**

(i) The battery has an e.m.f. of 24V and negligible internal resistance. The solenoid is made from copper wire. The wire has radius  $4.6 \times 10^{-4}$  m and total length 130 m. The resistivity of copper is  $1.7 \times 10^{-8} \Omega \text{ m}$ . Calculate the current in the solenoid.

current = ..... A [3]



9

- (ii) A tiny electrical spark is created between the contacts of the switch **S** as it is opened. The spark is produced because an e.m.f. is induced across the ends of the solenoid by the collapse of the magnetic flux linked with the solenoid.

The initial magnetic flux density within the solenoid is 0.090T and may be assumed to be uniform. The solenoid has 1100 turns and cross-sectional area  $1.3 \times 10^{-3} \text{m}^2$ .

The average e.m.f. induced across the ends of the solenoid is 150V. Estimate the time taken for the magnetic flux to collapse to zero.

time = ..... s [3]

[Total: 7]

10

5 (a) The diameter of a nucleus is about  $10^{-14}$  m.

(i) Complete the sentence below.

The diameter of a nucleus is ..... times smaller than the diameter of an atom. [1]

(ii) Very high-energy electrons are diffracted by the nucleus when they have a wavelength similar to the nuclear diameter.

1 Estimate the momentum of an electron with a de Broglie wavelength equal to the diameter of a nucleus.

momentum = .....  $\text{kg m s}^{-1}$  [2]

2 Suggest why the speed of these electrons cannot be calculated by dividing the answer to (ii)1 by the mass  $9.11 \times 10^{-31}$  kg.

.....  
.....  
.....  
..... [1]

11

- (b) The table of Fig. 5.1 shows some of the isotopes of phosphorus and, where they are unstable, the type of decay.

<b>Isotope</b>	$^{29}_{15}\text{P}$	$^{30}_{15}\text{P}$	$^{31}_{15}\text{P}$	$^{32}_{15}\text{P}$	$^{33}_{15}\text{P}$
<b>Type of decay</b>	$\beta^+$	$\beta^+$	stable	$\beta^-$	$\beta^-$

Fig. 5.1

- (i) State the difference between each of the isotopes shown in the table.

.....  
 ..... [1]

- (ii) Describe the structure of the proton in terms of up (u) and down (d) quarks.

..... [1]

- (iii) Describe what happens in a beta-plus ( $\beta^+$ ) decay using a quark model.

.....  
 .....  
 ..... [2]

- (iv) State **two** quantities conserved in a beta decay.

.....  
 ..... [1]

- (v) Examine the table of isotopes in Fig. 5.1 and suggest what determines whether an isotope emits  $\beta^+$  or  $\beta^-$ .

.....  
 .....  
 ..... [1]

[Total: 10]

6 (a) Explain what is meant by the statement below.

*Radioactivity is a random process.*

.....  
 ..... [1]

(b) Uranium-235 was present during the formation of the Solar System, including the Earth. The percentage of the original quantity of  ${}_{92}^{235}\text{U}$  found in rocks today is 1.1%. The half-life of  ${}_{92}^{235}\text{U}$  is  $7.1 \times 10^8$  years. Calculate the age, in years, of the Earth.

age = ..... y [3]

(c) Fig. 6.1 shows the variation of binding energy per nucleon against nucleon number  $A$ .

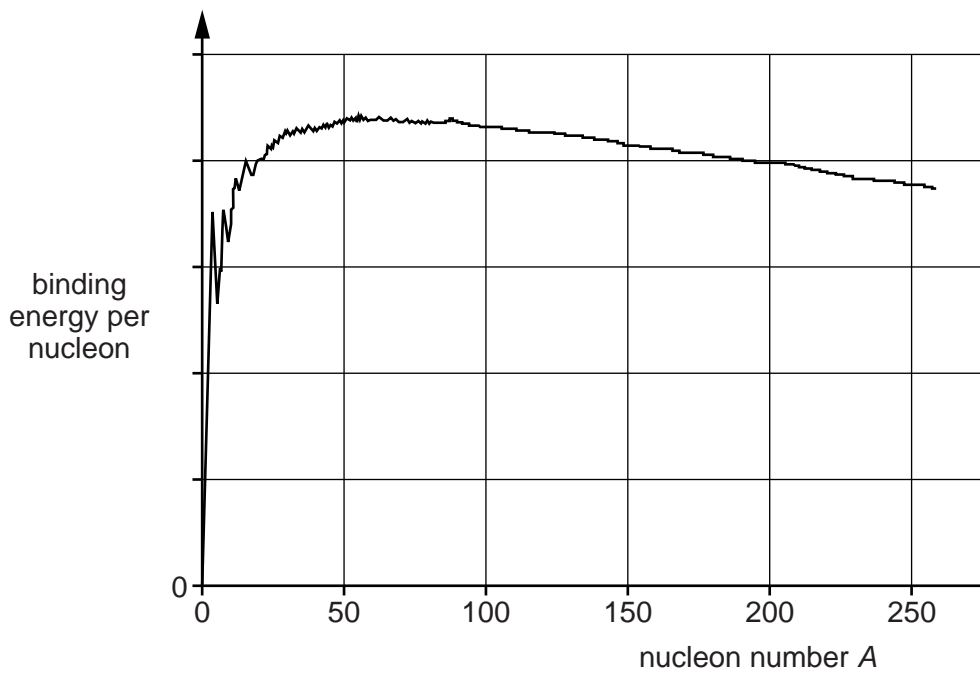

Fig. 6.1

## 13

- (i) Use Fig. 6.1 to estimate the value of the nucleon number of the most stable isotope.

..... [1]

- (ii) Use Fig. 6.1 to explain why nuclei of  ${}_{42}^{100}\text{Mo}$  cannot produce energy by **fusion**.

.....

.....

..... [1]

- (iii) The mass of a  ${}_{4}^{8}\text{Be}$  nucleus is  $1.329 \times 10^{-26}$  kg. Use data provided on the second page of the Data, Formulae and Relationships Booklet to determine the binding energy per nucleon for this nucleus.

binding energy per nucleon = ..... J [4]

**[Total: 10]**

7 (a) State **two** main properties of X-ray photons.

.....

.....

..... [2]

(b) Fig. 7.1 shows an X-ray photon interacting with an atom to produce an electron-positron pair in a process known as pair production.

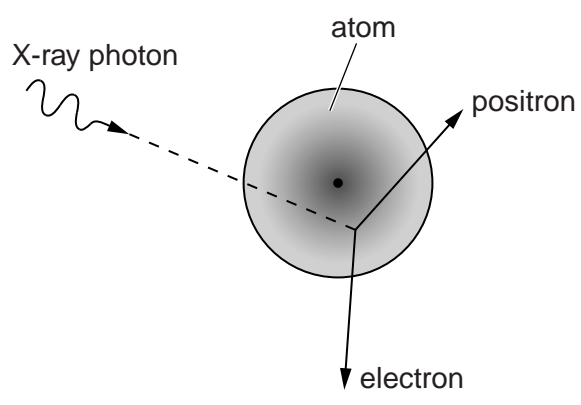

Fig. 7.1

Calculate the maximum wavelength of X-rays that can produce an electron-positron pair.

wavelength = ..... m [3]

(c) Name an element used as a contrast material in X-ray imaging. Explain why contrast materials are used in the diagnosis of stomach problems.

.....

.....

.....

.....

.....

..... [3]

[Total: 8]

## 15

- 8 Technetium-99m is a common medical tracer injected into patients before they have a scan with a gamma camera. Technetium-99m is a gamma emitter with a half-life of about 6 hours. Each gamma ray photon has energy  $2.2 \times 10^{-14}$  J.

A patient is given a dose with an initial activity of 500 MBq.

- (a) Explain what is meant by *activity*.

.....  
..... [1]

- (b) Calculate the initial rate of energy emission from the dose of technetium-99m.

rate of energy emission = .....  $\text{J s}^{-1}$  [2]

**Question 8 continues on page 16**





9 (a) State **two** main properties of ultrasound.

.....  
.....  
..... [2]

(b) Describe how the piezoelectric effect is used in an ultrasound transducer both to emit and receive ultrasound.

.....  
.....  
.....  
..... [2]

(c) Explain why a gel is used between the ultrasound transducer and the patient's skin during a scan.

.....  
.....  
.....  
.....  
..... [2]

(d) Explain a method using ultrasound to determine the speed of blood in an artery in the arm.

.....  
.....  
.....  
.....  
.....  
..... [4]

[Total: 10]

Turn over

10 (a) Calculate the distance of 1 light-year (ly) in metres.

distance = ..... m [1]

(b) Fig. 10.1 shows an incomplete diagram drawn by a student to show what is meant by a distance of 1 parsec (pc).

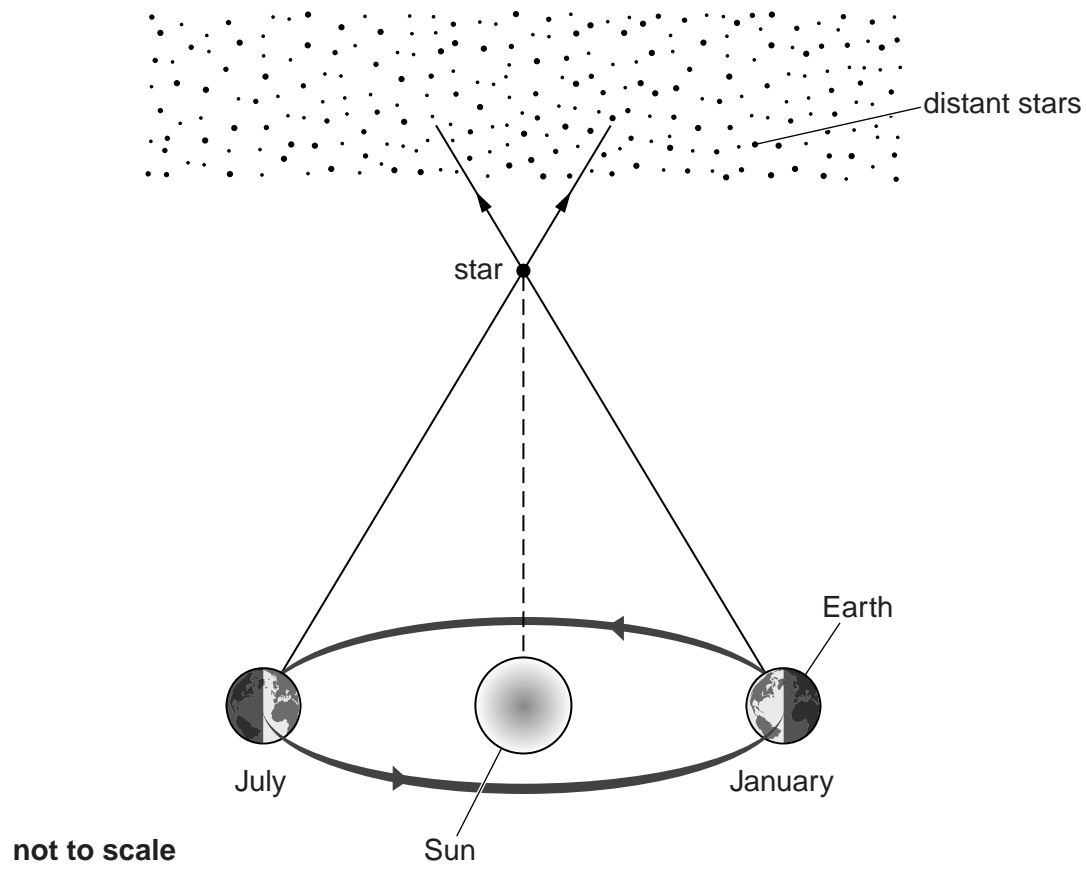

Fig. 10.1

Complete Fig. 10.1 by showing the distances of 1 pc and 1 AU, and the parallax angle of 1 second of arc (1"). [1]

19

(c) A recent supernova, SN2011fe, in the Pinwheel galaxy, M101, released  $10^{44}$  J of energy. The supernova is  $2.1 \times 10^7$  ly away.

(i) Calculate the distance of this supernova in pc.

$$1 \text{ pc} = 3.1 \times 10^{16} \text{ m}$$

distance = ..... pc [2]

(ii) Our Sun radiates energy at a rate of  $4 \times 10^{26}$  W. Estimate the time in years that it would take the Sun to release the same energy as the supernova SN2011fe.

time = ..... y [2]

(d) One of the possible remnants of a supernova event is a black hole. State **two** properties of a black hole.

.....

.....

.....

..... [2]

[Total: 8]

20

11 (a) One estimate of the age of the universe is  $13.7 \times 10^9$  years.

(i) Calculate the Hubble constant in  $\text{km s}^{-1} \text{Mpc}^{-1}$  using this age.

$$1 \text{ pc} = 3.09 \times 10^{16} \text{ m}$$

Hubble constant = .....  $\text{km s}^{-1} \text{Mpc}^{-1}$  [3]

(ii) The wavelength of the hydrogen-alpha spectral line in the laboratory is 656 nm. Calculate the observed wavelength of this spectral line in the spectrum of the galaxy NGC 7469, which is 50.0 Mpc away from the Earth.

wavelength = ..... nm [4]



- (c) Suggest how the microwave background radiation may evolve in the future.

.....

.....

.....

..... [2]

- (d) Recent observations of very distant supernovae have shown that the expansion of the universe may be accelerating. It is suggested that this is caused by *dark energy* which has the mysterious property of exerting a repulsive force on the universe. The universe may therefore be *open* rather than *flat* or *closed*.



Fig. 11.1

Complete Fig. 11.1 by sketching a suitable graph to illustrate an open universe. [1]

[Total: 15]

END OF QUESTION PAPER

**ADDITIONAL ANSWER SPACE**

If additional answer space is required, you should use the following lined page. The question number(s) must be clearly shown in the margins.

A large rectangular area with a solid vertical line on the left side and horizontal dotted lines extending across the page, providing space for writing answers.

**PLEASE DO NOT WRITE ON THIS PAGE**



**Copyright Information**

OCR is committed to seeking permission to reproduce all third-party content that it uses in its assessment materials. OCR has attempted to identify and contact all copyright holders whose work is used in this paper. To avoid the issue of disclosure of answer-related information to candidates, all copyright acknowledgements are reproduced in the OCR Copyright Acknowledgements Booklet. This is produced for each series of examinations and is freely available to download from our public website ([www.ocr.org.uk](http://www.ocr.org.uk)) after the live examination series.

If OCR has unwittingly failed to correctly acknowledge or clear any third-party content in this assessment material, OCR will be happy to correct its mistake at the earliest possible opportunity.

For queries or further information please contact the Copyright Team, First Floor, 9 Hills Road, Cambridge CB2 1GE.

OCR is part of the Cambridge Assessment Group; Cambridge Assessment is the brand name of University of Cambridge Local Examinations Syndicate (UCLES), which is itself a department of the University of Cambridge.