

Wednesday 23 January 2013 – Afternoon

A2 GCE PHYSICS A

G485/01 Fields, Particles and Frontiers of Physics

Candidates answer on the Question Paper.

OCR supplied materials:

- Data, Formulae and Relationships Booklet (sent with general stationery)

Other materials required:

- Electronic calculator

Duration: 2 hours



Candidate forename		Candidate surname	
-----------------------	--	----------------------	--

Centre number						Candidate number				
---------------	--	--	--	--	--	------------------	--	--	--	--

INSTRUCTIONS TO CANDIDATES

- Write your name, centre number and candidate number in the boxes above. Please write clearly and in capital letters.
- Use black ink. HB pencil may be used for graphs and diagrams only.
- Answer **all** the questions.
- Read each question carefully. Make sure you know what you have to do before starting your answer.
- Write your answer to each question in the space provided. If additional space is required, you should use the lined pages at the end of this booklet. The question number(s) must be clearly shown.
- Do **not** write in the bar codes.

INFORMATION FOR CANDIDATES

- The number of marks is given in brackets [] at the end of each question or part question.
- The total number of marks for this paper is **100**.
- You may use an electronic calculator.
- You are advised to show all the steps in any calculations.



Where you see this icon you will be awarded marks for the quality of written communication in your answer.

This means for example you should:

- ensure that text is legible and that spelling, punctuation and grammar are accurate so that meaning is clear;
- organise information clearly and coherently, using specialist vocabulary when appropriate.
- This document consists of **24** pages. Any blank pages are indicated.

Answer **all** the questions.

1 (a) Fig. 1.1 shows a circuit with a capacitor of capacitance C .

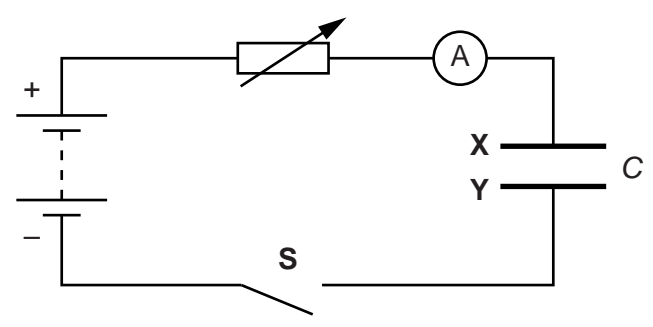

Fig. 1.1

The switch **S** is closed. The resistance of the variable resistor is manually adjusted so that the current in the circuit is kept **constant**.

(i) Explain in terms of movement of electrons how the capacitor plates **X** and **Y** acquire an equal but opposite charge.

.....

.....

.....

.....

.....

..... [2]

(ii) The initial charge on the capacitor is zero. After 100s, the potential difference across the capacitor is 1.6V. The constant current in the circuit is $40\mu\text{A}$.

1 Calculate the capacitance C of the capacitor.

$C = \dots\dots\dots \text{F}$ [3]

3

- 2 On Fig. 1.2, sketch a graph to show the variation of potential difference V across the capacitor with time t .

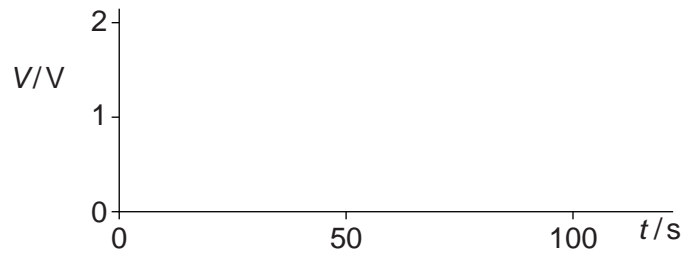

Fig. 1.2

[2]

- (b) Fig. 1.3 shows an arrangement used to determine the speed of a bullet.

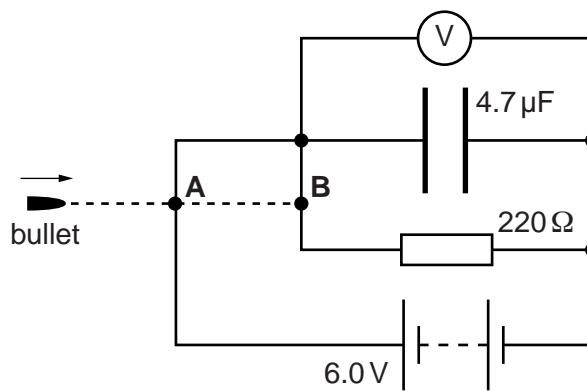

Fig. 1.3

The value of the resistance of the resistor and the value of the capacitance of the capacitor are shown in Fig. 1.3. The voltmeter reading is initially 6.0V. The bullet first breaks the circuit at **A**. The capacitor starts to discharge **exponentially** through the resistor. The capacitor stops discharging when the bullet breaks the circuit at **B**. The final voltmeter reading is 4.0V.

- (i) Calculate the time taken for the bullet to travel from **A** to **B**.

time = s [3]

- (ii) The separation between **A** and **B** is 0.10 m. Calculate the speed of the bullet.

speed = ms^{-1} [1]

[Total: 11]
Turn over

2 (a) Define *electric field strength* at a point in space.

.....
 [1]

(b) Fig. 2.1 shows an evenly spaced grid.

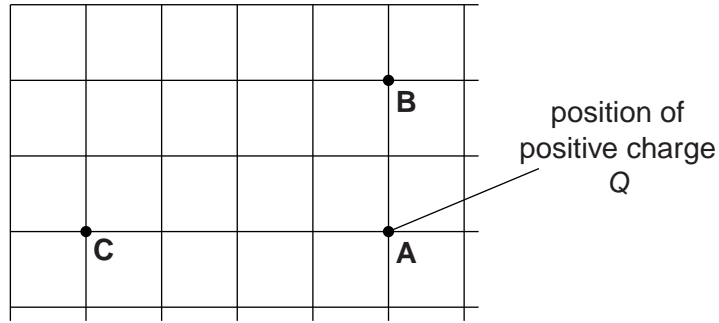

Fig. 2.1

A, **B** and **C** are points on the grid. A positive charge Q is placed on the grid at point **A**. The magnitude of the electric field strength at point **B** due to the charge Q is $8.0 \times 10^5 \text{ NC}^{-1}$.

(i) Apart from the magnitudes of the electric field strength, state another difference between the electric field at points **B** and **C**.

.....
 [1]

(ii) Determine the magnitude of the electric field strength at point **C**.

electric field strength = NC^{-1} [2]

5

(c) The simplest atom is that of hydrogen with one proton and one electron, see Fig. 2.2.

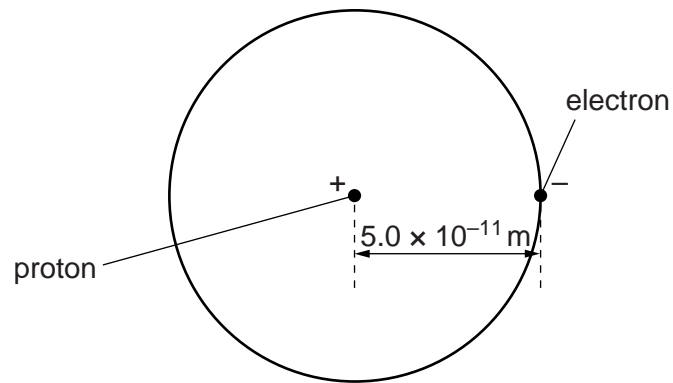

Fig. 2.2

The mean separation between the proton and the electron is shown in Fig. 2.2.

(i) Calculate the magnitude of the electrical force F_E acting on the electron.

$$F_E = \dots\dots\dots \text{N} \quad [3]$$

(ii) The gravitational force F_G acting on the electron due to the proton is very small compared with the electrical force F_E it experiences.

Calculate the ratio $\frac{F_E}{F_G}$.

$$\text{ratio} = \dots\dots\dots [2]$$

6

- (iii) A simplified model of the hydrogen atom suggests that the de Broglie wavelength of the electron is four times the mean separation between the proton and the electron shown in Fig. 2.2.

Estimate

- 1 the momentum p of the electron

$$p = \dots\dots\dots \text{kgms}^{-1} \quad [3]$$

- 2 the kinetic energy E_k of the electron.

$$E_k = \dots\dots\dots \text{J} \quad [3]$$

[Total: 15]

3 Fig. 3.1 shows a section through a mass spectrometer.

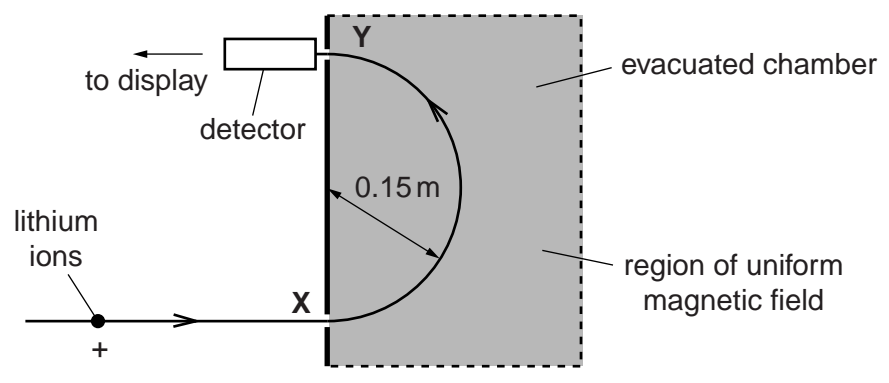

Fig. 3.1

A beam of positive lithium ions enter the evacuated chamber through the hole at X. The ions travel through a region of uniform magnetic field. The magnetic field is directed vertically into the plane of the diagram. The ions exit and are detected at Y.

(a) Name the rule that may be used to determine the direction of the force acting on the ions.
 [1]

(b) Explain why the speed of the ions travelling from X to Y in the magnetic field does not change despite the force acting on the ions.

 [1]

(c) The lithium-7 ions are detected at Y. All the ions have the same speed, $4.0 \times 10^5 \text{ ms}^{-1}$ and charge, $+1.6 \times 10^{-19} \text{ C}$. The radius of the semi-circular path of the ions in the magnetic field is 0.15 m. The mass of a lithium-7 ion is $1.2 \times 10^{-26} \text{ kg}$.

(i) Calculate the force acting on a lithium ion as it moves in the semi-circle.

force = N [2]

(ii) Calculate the magnitude of the magnetic flux density B .

$B = \dots\dots\dots$ T [2]

(iii) The current recorded by the detector at Y is 4.8×10^{-9} A. Calculate the number of lithium-7 ions reaching the detector per second.

number per second = $\dots\dots\dots$ s⁻¹ [2]

(d) Fig. 3.2 shows the variation of current I in the detector with magnetic flux density B .

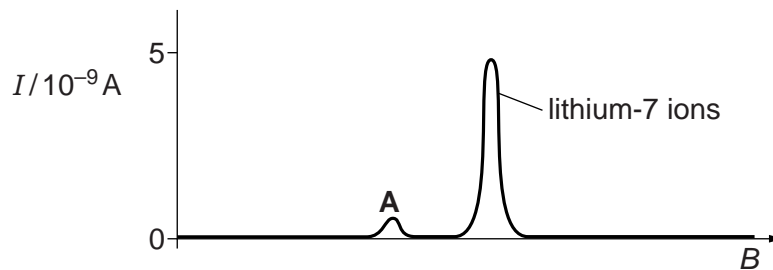

Fig. 3.2

The peak **A** is due to ions of another isotope of lithium. These ions have the same speed and charge as the lithium-7 ions. Explain the significance of the 'height' and position of peak **A**.

.....

.....

.....

.....

.....

..... [2]

[Total: 10]

Turn over

- 4 (a) In the core of a nuclear reactor, one of the many fission reactions of the uranium-235 nucleus is shown below.

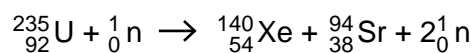

- (i) State **one** quantity that is conserved in this fission reaction.

..... [1]

- (ii) Fig. 4.1 illustrates this fission reaction.

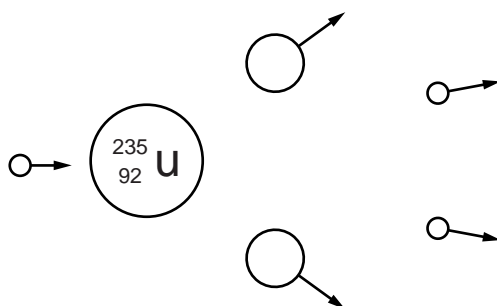
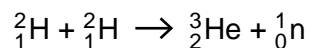

Fig. 4.1

Label all the particles in Fig. 4.1 and extend the diagram to show how a chain reaction might develop. [2]

- (b) Fusion of hydrogen nuclei is the source of energy in most stars. A typical reaction is shown below.



The ${}_{1}^{2}\text{H}$ nuclei repel each other. Fusion requires the ${}_{1}^{2}\text{H}$ nuclei to get very close and this usually occurs at very high temperatures, typically 10^9K .

11

- (i) Use the data below to calculate the energy released in the fusion reaction above.

$$\text{mass of } {}^2_1\text{H nucleus} = 3.343 \times 10^{-27} \text{ kg}$$

$$\text{mass of } {}^3_2\text{He nucleus} = 5.006 \times 10^{-27} \text{ kg}$$

$$\text{mass of } {}^1_0\text{n} = 1.675 \times 10^{-27} \text{ kg}$$

energy = J [3]

- (ii) State in what form the energy in (b)(i) is released.

..... [1]

- (iii) The ${}^2_1\text{H}$ nuclei in stars can be modelled as an ideal gas. Calculate the mean kinetic energy of the ${}^2_1\text{H}$ nuclei at 10^9K .

energy = J [2]

- (iv) Suggest why some fusion can occur at a temperature as low as 10^7K .

.....

 [1]

[Total: 10]

12

- 5 Fluorodeoxyglucose (FDG) is a radiopharmaceutical used for PET scans. It contains radioactive fluorine-18, which is a positron-emitter with a half-life of 6.6×10^3 s. A patient is injected with FDG which has an initial activity of 250 MBq.

(a) Calculate the decay constant of fluorine-18.

decay constant = s^{-1} [2]

(b) Show that the initial number of fluorine-18 nuclei in the FDG is about 2×10^{12} .

[1]

(c) About 9.9% of the mass of FDG is fluorine-18. Use your answer in (b) to determine the initial mass of FDG given to the patient. The molar mass of fluorine-18 is $0.018 \text{ kg mol}^{-1}$.

mass = kg [3]

- 6 (a) Describe briefly how X-rays are produced in an X-ray tube.

.....

 [2]

- (b) Describe the Compton Effect in terms of an X-ray photon.

.....

 [2]

- (c) A beam of X-rays of intensity $3.0 \times 10^9 \text{ W m}^{-2}$ is used to target a tumour in a patient. The tumour is situated at a depth of 1.7 cm in soft tissue. The attenuation (absorption) coefficient μ of soft-tissues is 6.5 cm^{-1} .

- (i) Show that the intensity of the X-rays at the tumour is about $5 \times 10^4 \text{ W m}^{-2}$.

[2]

- (ii) The cross-sectional area of the X-ray beam at the tumour is 5 mm^2 . The energy required to destroy the malignant cells of the tumour is 200 J. The tumour absorbs 10% of the energy from the X-rays. Calculate the total exposure time required to destroy the tumour.

time = s [3]

(b) An MRI scan can take a long time and it does produce an unpleasant loud noise. State one other disadvantage and one advantage of an MRI scan.

disadvantage

.....

advantage

..... [2]

[Total: 8]

19

- (i) The final evolutionary stage of the star is a white dwarf. Describe some of the characteristics of a white dwarf.

.....
.....
..... [2]

- (ii) Explain why, in its evolution, the star is brightest when at its coolest.

.....
.....
.....
..... [2]

[Total: 8]

20

- 9 (a) State Olbers' paradox and the two assumptions made about the Universe.

.....
.....
.....
.....
..... [3]

- (b) State Hubble's law and explain how it resolves Olbers' paradox.

.....
.....
.....
.....
..... [2]

- (c) A galaxy at a distance of 1.4×10^{25} m is observed to be receding from the Earth at a velocity of 3.4×10^7 ms⁻¹.

- (i) Calculate the Hubble constant H_0 based on this data.

$$H_0 = \dots\dots\dots \text{unit} \dots\dots\dots [3]$$

21

(ii) Estimate

1 the age in years of the Universe

$$1 \text{ year} = 3.2 \times 10^7 \text{ s}$$

age =years [2]

2 the maximum distance in parsec (pc) we can observe from the Earth.

$$1 \text{ pc} = 3.1 \times 10^{16} \text{ m}$$

distance = pc [2]

[Total: 12]

END OF QUESTION PAPER