

Write your name here

Surname	Other names
---------	-------------

**Pearson Edexcel**

**Level 3 GCE**

Centre Number

--	--	--	--	--

Candidate Number

--	--	--	--

**Physics**

**Advanced**

**Paper 2: Advanced Physics II**

Friday 8 June 2018 – Morning

**Time: 1 hour 45 minutes**

Paper Reference

**9PH0/02**

**You must have:**

Ruler

Total Marks

### Instructions

- Use **black** ink or ball-point pen.
- **Fill in the boxes** at the top of this page with your name, centre number and candidate number.
- Answer **all** questions.
- Answer the questions in the spaces provided – *there may be more space than you need.*

### Information

- The total mark for this paper is 90.
- The marks for **each** question are shown in brackets – *use this as a guide as to how much time to spend on each question.*
- You may use a scientific calculator.
- In questions marked with an **asterisk** (\*), marks will be awarded for your ability to structure your answer logically, showing how the points that you make are related or follow on from each other where appropriate.

### Advice

- Read each question carefully before you start to answer it.
- Try to answer every question.
- Check your answers if you have time at the end.
- You are advised to show your working in calculations, including units where appropriate.

Turn over ►

P52362A

©2018 Pearson Education Ltd.

1/1/1/1/1/1/



  
Pearson

Answer ALL questions.

All multiple choice questions must be answered with a cross  $\boxtimes$  in the box for the correct answer from A to D. If you change your mind about an answer, put a line through the box  $\boxtimes$  and then mark your new answer with a cross  $\boxtimes$ .

- 1 A system of lenses consists of a converging lens and a diverging lens in contact.

The magnitude of the power of the converging lens is 9.4 D and the magnitude of the power of the diverging lens is 4.2 D.

Which of the following is the power of this system of lenses?

- A 13.6 D  
 B 5.2 D  
 C -5.2 D  
 D -13.6 D

(Total for Question 1 = 1 mark)

- 2 A sample of an ideal gas has pressure  $p$ , volume  $V$  and absolute temperature  $T$ .

The volume of the gas is decreased to  $\frac{2}{3}V$  and the temperature increased to  $\frac{6}{5}T$ .

Which of the following is the new pressure of the gas?

- A  $\frac{5}{9}p$   
 B  $\frac{4}{5}p$   
 C  $\frac{5}{4}p$   
 D  $\frac{9}{5}p$

(Total for Question 2 = 1 mark)



3 A deforming force is applied to a sample of material.

Which row of the table shows the axes of a graph for which the gradient is stiffness  $k$ ?

	<b>y-axis</b>	<b>x-axis</b>
<input type="checkbox"/> A	extension	force
<input type="checkbox"/> B	force	length
<input type="checkbox"/> C	stress	strain
<input type="checkbox"/> D	strain	length

(Total for Question 3 = 1 mark)

4 For total internal reflection to take place, the angle of incidence must be

- A greater than or equal to the critical angle.
- B greater than the critical angle.
- C less than or equal to the critical angle.
- D less than the critical angle.

(Total for Question 4 = 1 mark)

5 Select the row of the table that describes the relative ionisation and relative penetration of nuclear radiations.

	<b>Most ionising</b>	<b>Most penetrating</b>
<input type="checkbox"/> A	$\alpha$	$\alpha$
<input type="checkbox"/> B	$\alpha$	$\gamma$
<input type="checkbox"/> C	$\gamma$	$\alpha$
<input type="checkbox"/> D	$\gamma$	$\gamma$

(Total for Question 5 = 1 mark)

DO NOT WRITE IN THIS AREA

DO NOT WRITE IN THIS AREA

DO NOT WRITE IN THIS AREA



- 6 When monochromatic light is incident on the surface of a metal, electrons are emitted by the photoelectric effect.

If other conditions are unchanged, the maximum kinetic energy of the electrons will be increased by

- A increasing the frequency of the incident light.
- B increasing the intensity of the incident light.
- C using a metal with a higher threshold frequency.
- D using a metal with a higher work function.

(Total for Question 6 = 1 mark)

- 7 A nucleus of protactinium,  ${}_{91}^{231}\text{Pa}$ , decays by emitting an  $\alpha$  particle.

The nucleus formed is

- A  ${}_{95}^{233}\text{Am}$
- B  ${}_{93}^{235}\text{Np}$
- C  ${}_{89}^{227}\text{Ac}$
- D  ${}_{87}^{229}\text{Fr}$

(Total for Question 7 = 1 mark)

DO NOT WRITE IN THIS AREA

DO NOT WRITE IN THIS AREA

DO NOT WRITE IN THIS AREA



- 8 The graph shows how the displacement of a simple harmonic oscillator varies with time.

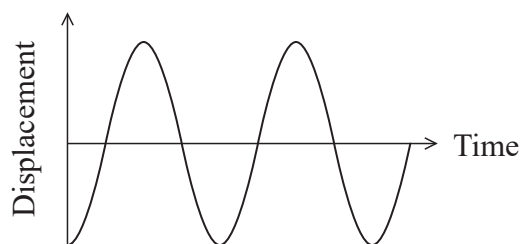

Which of the following graphs shows how velocity varies with time for the same oscillator, over the same time period?

A

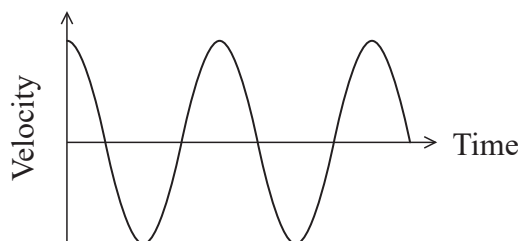

B

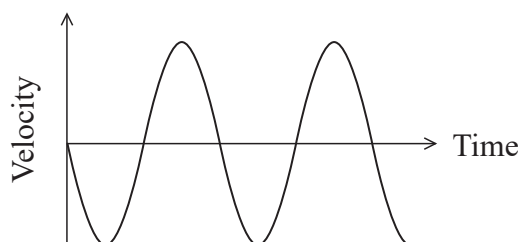

C

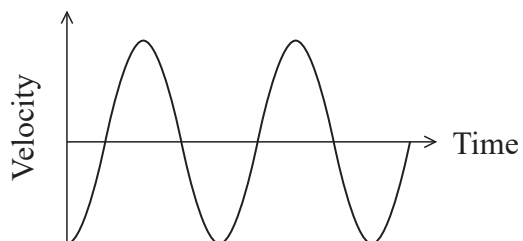

D

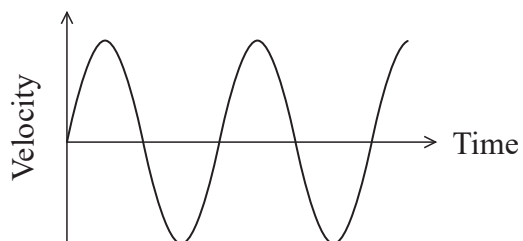

(Total for Question 8 = 1 mark)



- 9 An object is placed 6.5 cm from a lens of focal length 3.9 cm. An image is formed 9.8 cm behind the lens.

Which of the following expressions is equal to the magnification?

- A  $\frac{3.9}{6.5}$
- B  $\frac{6.5}{9.8}$
- C  $\frac{6.5}{3.9}$
- D  $\frac{9.8}{6.5}$

(Total for Question 9 = 1 mark)

- 10 A monochromatic beam of light of wavelength  $\lambda$  from a laser is directed at a diffraction grating of line spacing  $d$ .

A student calculates the value of  $d/\lambda$  in order to determine the expected number of visible maxima.

The calculated value of  $d/\lambda$  is 4.7

How many maxima are visible?

- A 4
- B 5
- C 9
- D 11

(Total for Question 10 = 1 mark)

DO NOT WRITE IN THIS AREA

DO NOT WRITE IN THIS AREA

DO NOT WRITE IN THIS AREA



- 11 (a) For an ideal gas  $pV = NkT$  and  $pV = \frac{1}{3}Nm \langle c^2 \rangle$ .

Use these relationships to show that the mean kinetic energy of a gas molecule is proportional to the absolute temperature.

(2)

.....

.....

.....

.....

.....

.....

- (b) The molecules in a sample of gas have a mass of  $5.0 \times 10^{-26}$  kg.

Calculate the root-mean-square speed of gas molecules in the gas at  $25^\circ\text{C}$ .

(3)

.....

.....

.....

.....

.....

.....

Root-mean-square speed = .....

(Total for Question 11 = 5 marks)

DO NOT WRITE IN THIS AREA

DO NOT WRITE IN THIS AREA

DO NOT WRITE IN THIS AREA



- 12 Infrared cameras are used to create images that show the infrared radiation emitted by objects.

The photographs show the same scene taken first with an ordinary camera and then with an infrared camera.

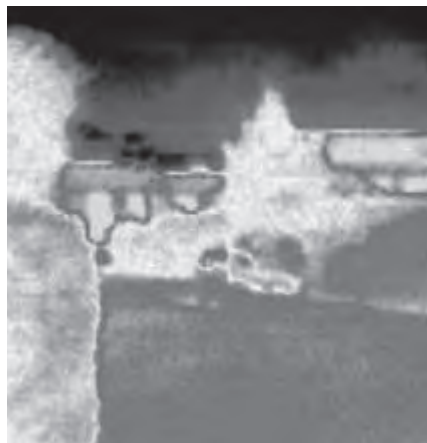

- (a) Deduce whether the objects shown in the photographs would be expected to have peak emissions at infrared wavelengths. Your answer should include a calculation.

(4)

longest wavelength of visible red light  $\approx 700 \text{ nm}$

.....

.....

.....

.....

.....

DO NOT WRITE IN THIS AREA

DO NOT WRITE IN THIS AREA

DO NOT WRITE IN THIS AREA





- (b) The photograph shows the result when someone tries to take an infrared photograph of the same scene through a window. The image does not show the outdoor scene but does show an image of the photographer.



State what can be concluded about glass and infrared radiation.

(2)

(Total for Question 12 = 6 marks)

DO NOT WRITE IN THIS AREA

DO NOT WRITE IN THIS AREA

DO NOT WRITE IN THIS AREA



13 Raindrops of different sizes fall with different terminal velocities through air.

The table shows the measured value of the terminal velocity for raindrops of different sizes.

Raindrop size	Drop diameter / mm	Terminal velocity / m s <sup>-1</sup>
small	0.5	2.1
medium	2.0	6.5
large	5.0	9.1

(a) Derive, using Stokes' law, the following expression for the terminal velocity  $v$  of a spherical raindrop in terms of its radius  $r$ .

$$v = \frac{2g\rho r^2}{9\eta}$$

where  $\rho$  is the density of rainwater and  $\eta$  is the viscosity of air.

You should ignore upthrust.

(2)

.....

.....

.....

.....

.....

DO NOT WRITE IN THIS AREA

DO NOT WRITE IN THIS AREA

DO NOT WRITE IN THIS AREA



(b) Show that the expression given in (a) produces a value of about  $800 \text{ m s}^{-1}$  for the terminal velocity of a large raindrop.

(2)

$$\rho = 1.0 \times 10^3 \text{ kg m}^{-3}$$

$$\eta = 1.8 \times 10^{-5} \text{ Pa s}$$

(c) Explain whether Stokes' law is suitable for calculating the terminal velocity of raindrops.

(3)

(Total for Question 13 = 7 marks)

DO NOT WRITE IN THIS AREA

DO NOT WRITE IN THIS AREA

DO NOT WRITE IN THIS AREA



14 In 1965, Richard Feynman proposed a double slit experiment to investigate the wave properties of electrons.

The experiment was later carried out using the arrangement shown.

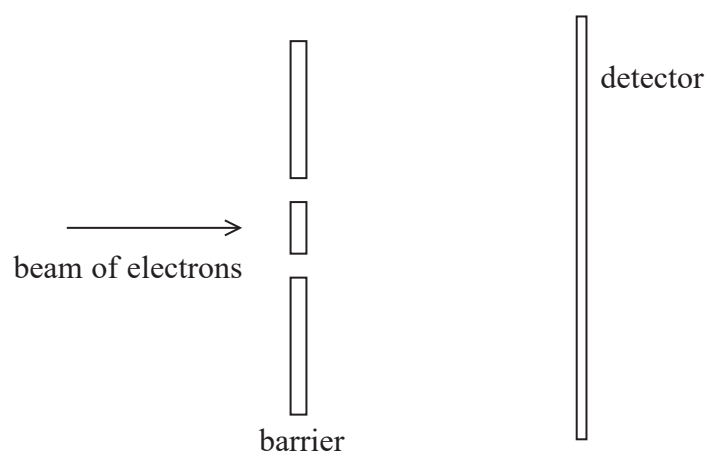

A beam of electrons was directed at a barrier with two slits.

The detector recorded the positions where electrons arrived after passing through the slits.

The following pattern was obtained. Black dots represent points where electrons were detected. A band where electrons were not detected has been labelled X and a band where electrons were detected has been labelled Y.

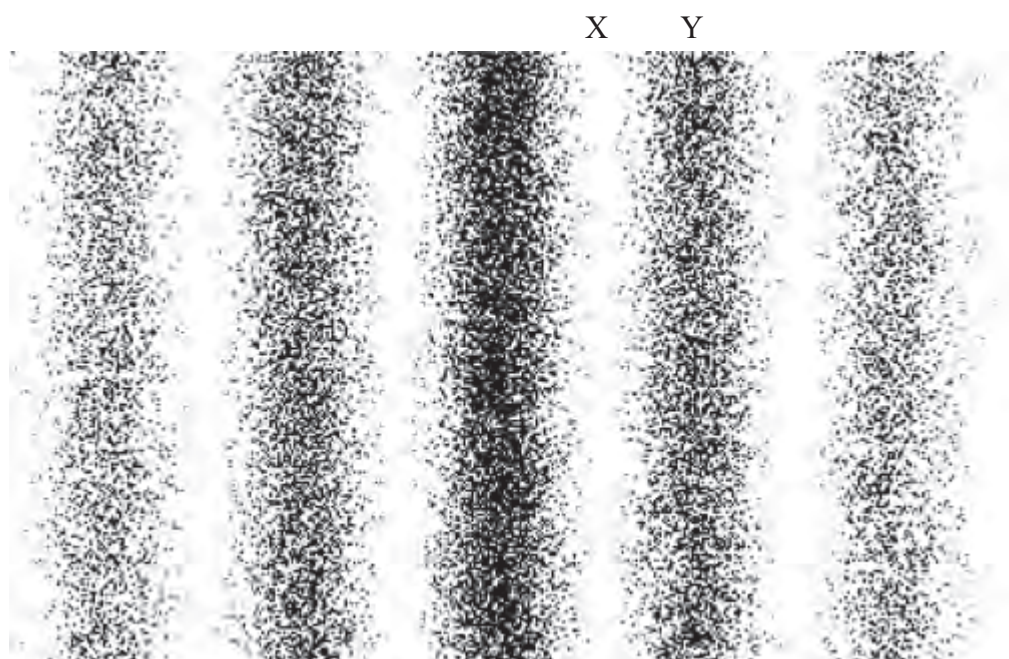

DO NOT WRITE IN THIS AREA

DO NOT WRITE IN THIS AREA

DO NOT WRITE IN THIS AREA



The path difference for electrons arriving at band X from the separate slits was  $2.5 \times 10^{-11}$  m.  
For electrons arriving at band Y the path difference was  $5.0 \times 10^{-11}$  m.

Explain why this pattern is observed when the electron energy is  $9.6 \times 10^{-17}$  J.

The electrons are travelling at non-relativistic speeds.

(6)

(Total for Question 14 = 6 marks)



P 5 2 3 6 2 A 0 1 3 3 2

DO NOT WRITE IN THIS AREA

DO NOT WRITE IN THIS AREA

DO NOT WRITE IN THIS AREA



DO NOT WRITE IN THIS AREA

DO NOT WRITE IN THIS AREA

DO NOT WRITE IN THIS AREA

(b) Calculate the velocity an object would have as it reached the surface of Mercury if it was released from Messenger's maximum orbital height. Assume the object is released from rest and that Mercury has no atmosphere.

(4)

.....

.....

.....

.....

.....

.....

.....

.....

.....

.....

.....

.....

.....

.....

.....

.....

.....

.....

.....

.....

.....

.....

Velocity = .....

**(Total for Question 15 = 10 marks)**



- 16 The diagram shows two identical pendulums, A and B, side by side with a rubber band placed over both strings.

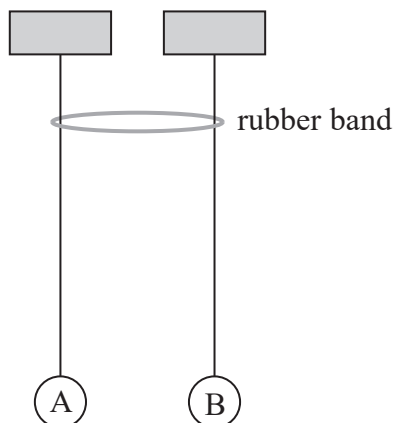

DO NOT WRITE IN THIS AREA

DO NOT WRITE IN THIS AREA

DO NOT WRITE IN THIS AREA

Pendulum A is displaced and starts to oscillate. As pendulum A oscillates, pendulum B starts to oscillate with the same time period, its amplitude increasing as the amplitude of pendulum A decreases. At one stage pendulum A is no longer oscillating and pendulum B has its maximum amplitude. Then pendulum A starts to oscillate again with increasing amplitude, as the amplitude of pendulum B decreases.

The apparatus is adjusted so that the pendulums do not have the same length as each other. When the first pendulum is set into oscillation, the second pendulum starts to oscillate, but with very small amplitude; the first pendulum does not stop oscillating.

\*(a) Explain this behaviour.

(6)





DO NOT WRITE IN THIS AREA

DO NOT WRITE IN THIS AREA

DO NOT WRITE IN THIS AREA

(b) The graph shows how the displacement of each pendulum varies with time at one stage in the motion.

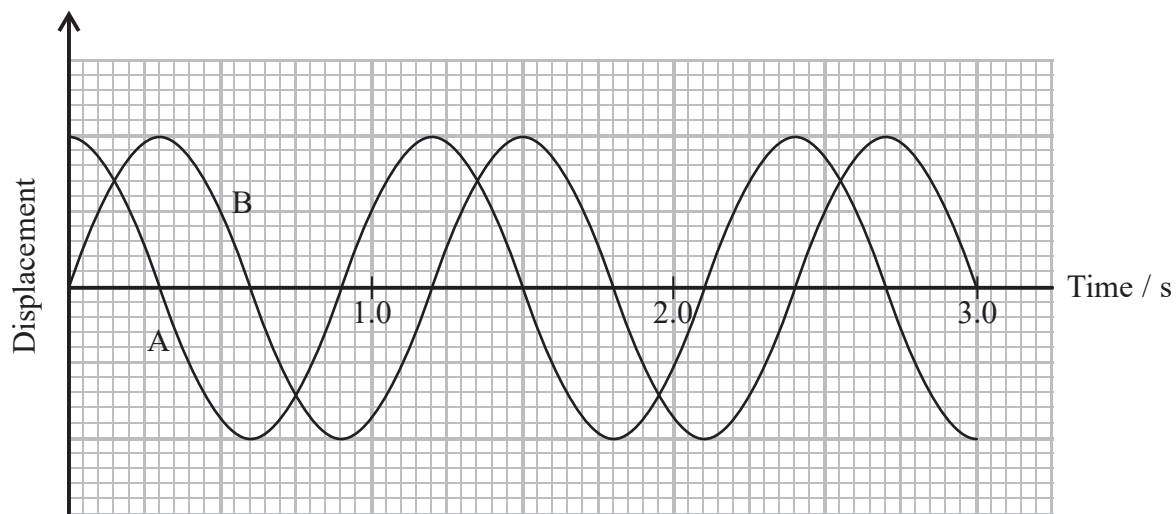

(i) State the phase relationship between the two pendulums.

(1)

.....

.....

(ii) Determine the length of pendulums A and B.

(3)

.....

.....

.....

.....

.....

.....

Length = .....

**(Total for Question 16 = 10 marks)**



17 The photograph shows a man wearing a virtual reality (VR) headset.



DO NOT WRITE IN THIS AREA

DO NOT WRITE IN THIS AREA

DO NOT WRITE IN THIS AREA

The VR headset gives the illusion of three-dimensional vision.

Inside the VR headset a pair of lenses is used to enable the user to focus on a magnified virtual image of a screen. The lenses can be changed to suit the vision of the user.



(a) In the VR headset the lens is between the eye and the screen, as shown below.

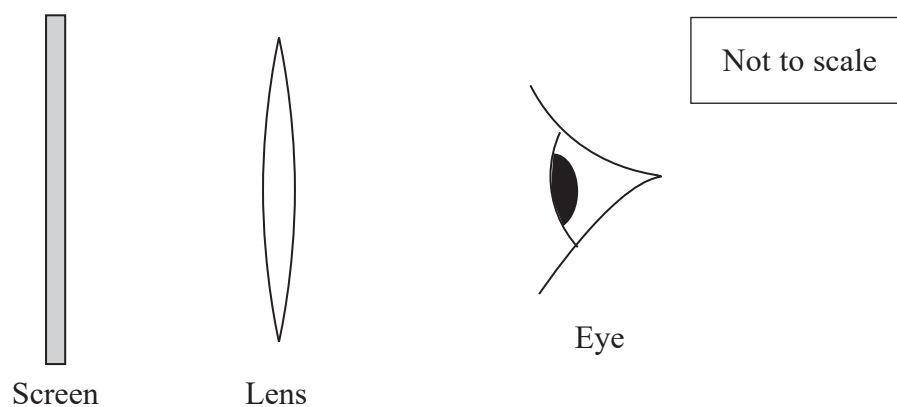

For a particular user of the headset, the image of the screen must be at least 16 cm from the eye and have a magnification of at least 3.0.

Determine whether this would be possible with a lens of focal length 3.8 cm.  
Your answer should include a full-scale ray diagram drawn on the grid provided.

(4)

distance from screen to lens = 2.8 cm

distance from lens to eye = 2.2 cm

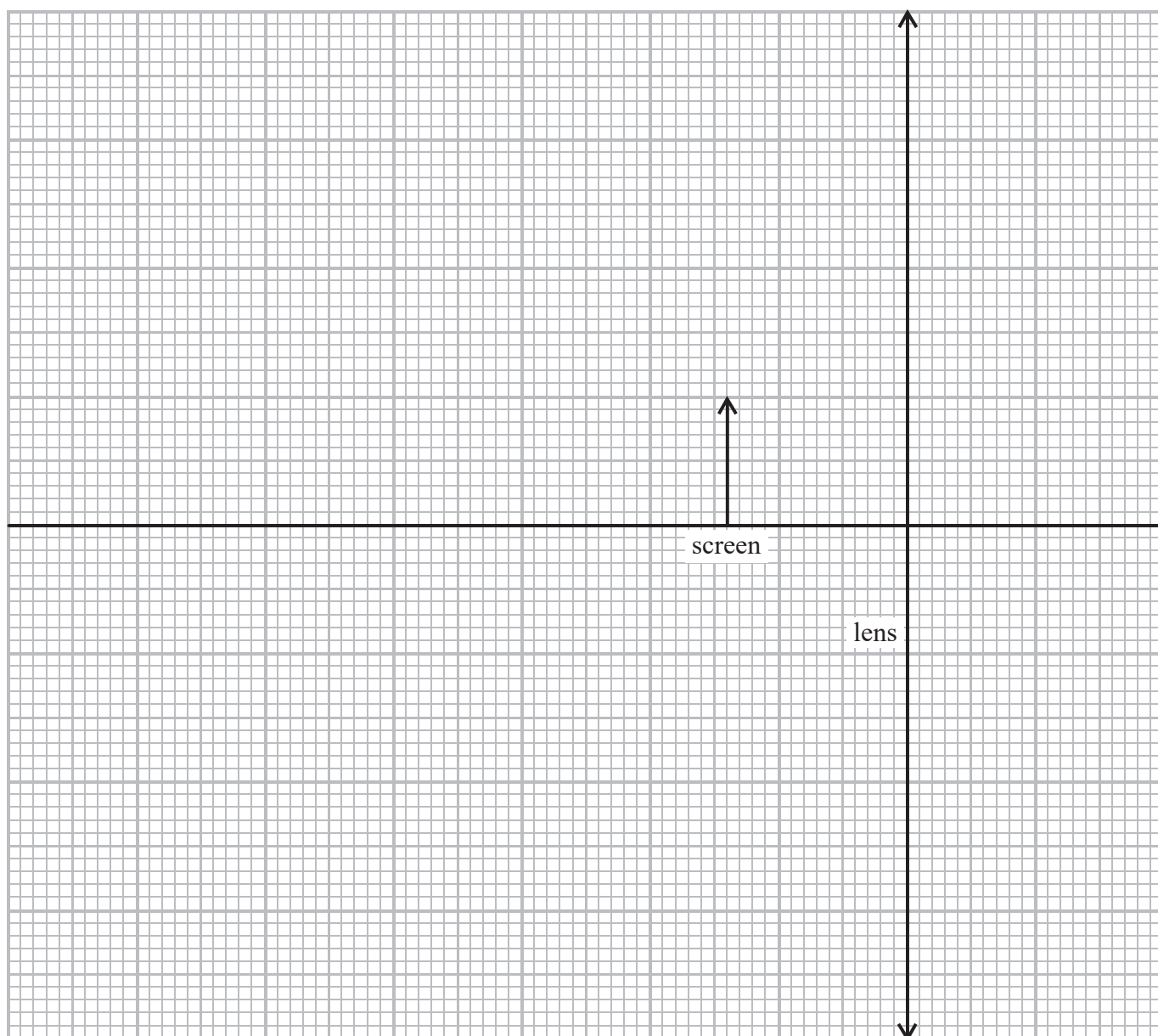

DO NOT WRITE IN THIS AREA

DO NOT WRITE IN THIS AREA

DO NOT WRITE IN THIS AREA



- (b) Plastic Fresnel lenses are used in the VR headset because they are thinner and lighter than traditional glass lenses.

Instead of the continuous curved surface of a converging lens the Fresnel lens has circular ridges, each with an edge at a different angle to the adjacent ridge, as shown in the simplified cross-section in Figure 1. Figure 2 shows a ray of light entering a section of the lens.



Figure 1

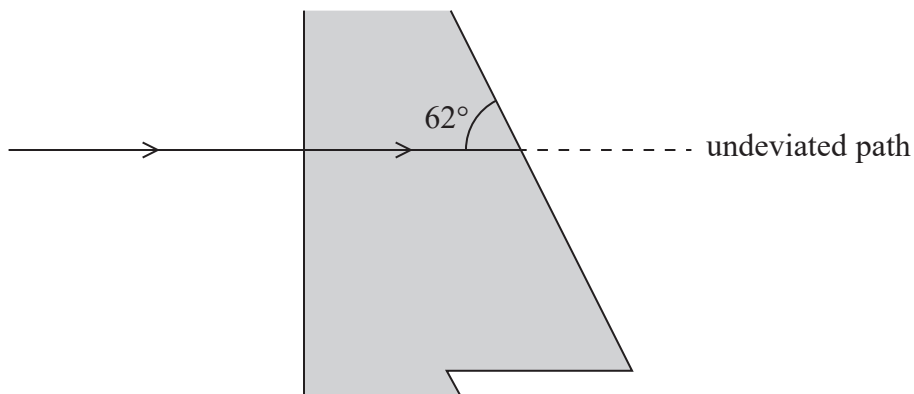

Figure 2

- (i) Calculate the angle through which the ray has been deviated as it emerges from the plastic. (4)

refractive index of plastic = 1.47

.....

.....

.....

.....

.....

.....

.....

.....

Angle = .....



(ii) Explain how the lens focuses a beam of light travelling parallel to the principal axis. (3)

.....

.....

.....

.....

.....

.....

.....

.....

**(Total for Question 17 = 11 marks)**

DO NOT WRITE IN THIS AREA

DO NOT WRITE IN THIS AREA

DO NOT WRITE IN THIS AREA



P 5 2 3 6 2 A 0 2 1 3 2

**18** Phosphogypsum is a by-product in the manufacture of fertiliser. It is slightly radioactive because of the presence of radium-226, a radioisotope with a half-life of 1600 years.

It must be stored securely as long as the activity of the radium-226 it contains is greater than 0.4 Bq per gram of phosphogypsum.

(a) (i) In a sample of 1.0 g of phosphogypsum, the activity of radium-226 is 1.3 Bq.

Calculate the number of nuclei of radium-226 in this sample.

(3)

Number of nuclei = .....

(ii) Calculate the time in years it would take before this sample reached the permitted level of decay rate.

(3)

Time = .....years

DO NOT WRITE IN THIS AREA

DO NOT WRITE IN THIS AREA

DO NOT WRITE IN THIS AREA



DO NOT WRITE IN THIS AREA

DO NOT WRITE IN THIS AREA

DO NOT WRITE IN THIS AREA

(b) Radium-226 decays to radon-222 by alpha emission.

Determine the energy released in MeV in the decay of a single nucleus of radium-226.

(5)

mass of radium-226 nucleus = 225.97713 u

mass of radon-222 nucleus = 221.97040 u

mass of  $\alpha$  particle = 4.00151 u

.....

.....

.....

.....

.....

.....

.....

.....

.....

.....

.....

.....

.....

.....

.....

.....

.....

.....

.....

.....

Energy released = ..... MeV

(Total for Question 18 = 11 marks)



19 In 2016 the Breakthrough Starshot initiative was announced. This project intends to send a fleet of small probes to Proxima Centauri, the nearest star to the Sun. This journey would take about twenty years.

(a) The radiation intensity at Earth from Proxima Centauri is  $3.25 \times 10^{-11} \text{ W m}^{-2}$ .  
The luminosity of the Sun is  $L_{\odot}$ .

(i) Show that the luminosity of Proxima Centauri is about  $0.002 L_{\odot}$ .

(3)

distance to Proxima Centauri =  $4.00 \times 10^{16} \text{ m}$

$L_{\odot} = 3.85 \times 10^{26} \text{ W}$

DO NOT WRITE IN THIS AREA

DO NOT WRITE IN THIS AREA

DO NOT WRITE IN THIS AREA





(ii) Proxima Centauri is described on a website as a main sequence star.

Determine whether the surface temperature of Proxima Centauri is consistent with a position on the main sequence of the Hertzsprung-Russell diagram.

(3)

radius of Proxima Centauri =  $9.81 \times 10^7$  m

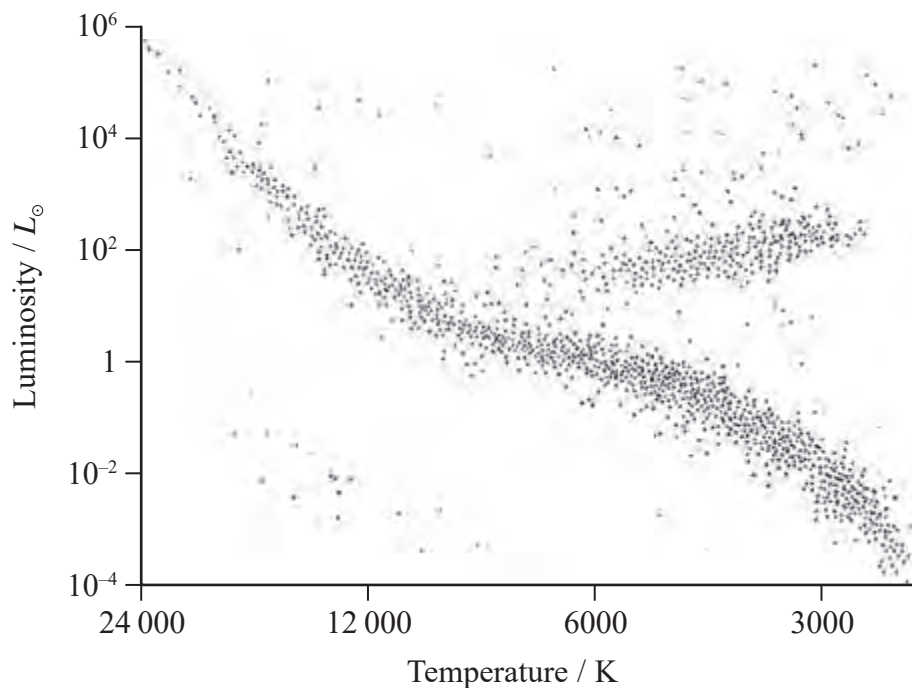

.....

.....

.....

.....

.....

.....



P 5 2 3 6 2 A 0 2 5 3 2

DO NOT WRITE IN THIS AREA

DO NOT WRITE IN THIS AREA

DO NOT WRITE IN THIS AREA



DO NOT WRITE IN THIS AREA

DO NOT WRITE IN THIS AREA

DO NOT WRITE IN THIS AREA

**BLANK PAGE**



DO NOT WRITE IN THIS AREA

DO NOT WRITE IN THIS AREA

DO NOT WRITE IN THIS AREA

**BLANK PAGE**



### List of data, formulae and relationships

Acceleration of free fall	$g = 9.81 \text{ m s}^{-2}$	(close to Earth's surface)
Boltzmann constant	$k = 1.38 \times 10^{-23} \text{ J K}^{-1}$	
Coulomb law constant	$k = \frac{1}{4\pi\epsilon_0} = 8.99 \times 10^9 \text{ N m}^2 \text{ C}^{-2}$	
Electron charge	$e = -1.60 \times 10^{-19} \text{ C}$	
Electron mass	$m_e = 9.11 \times 10^{-31} \text{ kg}$	
Electronvolt	$1 \text{ eV} = 1.60 \times 10^{-19} \text{ J}$	
Gravitational constant	$G = 6.67 \times 10^{-11} \text{ N m}^2 \text{ kg}^{-2}$	
Gravitational field strength	$g = 9.81 \text{ N kg}^{-1}$	(close to Earth's surface)
Permittivity of free space	$\epsilon_0 = 8.85 \times 10^{-12} \text{ F m}^{-1}$	
Planck constant	$h = 6.63 \times 10^{-34} \text{ J s}$	
Proton mass	$m_p = 1.67 \times 10^{-27} \text{ kg}$	
Speed of light in a vacuum	$c = 3.00 \times 10^8 \text{ m s}^{-1}$	
Stefan-Boltzmann constant	$\sigma = 5.67 \times 10^{-8} \text{ W m}^{-2} \text{ K}^{-4}$	
Unified atomic mass unit	$u = 1.66 \times 10^{-27} \text{ kg}$	

#### Mechanics

##### Kinematic equations of motion

$$s = \frac{(u + v)t}{2}$$

$$v = u + at$$

$$s = ut + \frac{1}{2}at^2$$

$$v^2 = u^2 + 2as$$

##### Forces

$$\Sigma F = ma$$

$$g = \frac{F}{m}$$

$$W = mg$$

$$\text{moment of force} = Fx$$

##### Momentum

$$p = mv$$

#### Work, energy and power

$$\Delta W = F\Delta s$$

$$E_k = \frac{1}{2}mv^2$$

$$\Delta E_{\text{grav}} = mg\Delta h$$

$$P = \frac{E}{t}$$

$$P = \frac{W}{t}$$

$$\text{efficiency} = \frac{\text{useful energy output}}{\text{total energy input}}$$

$$\text{efficiency} = \frac{\text{useful power output}}{\text{total power input}}$$



**Electric circuits**Potential difference

$$V = \frac{W}{Q}$$

Resistance

$$R = \frac{V}{I}$$

Electrical power and energy

$$P = VI$$

$$P = I^2R$$

$$P = \frac{V^2}{R}$$

$$W = VIt$$

Resistivity

$$R = \frac{\rho l}{A}$$

Current

$$I = \frac{\Delta Q}{\Delta t}$$

$$I = nqvA$$

**Materials**Density

$$\rho = \frac{m}{V}$$

Stokes' law

$$F = 6\pi\eta r v$$

Hooke's law

$$\Delta F = k\Delta x$$

Young modulus

$$\text{Stress } \sigma = \frac{F}{A}$$

$$\text{Strain } \varepsilon = \frac{\Delta x}{x}$$

$$E = \frac{\sigma}{\varepsilon}$$

Elastic strain energy

$$\Delta E_{\text{el}} = \frac{1}{2}F\Delta x$$

**Waves and Particle Nature of Light**Wave speed

$$v = f\lambda$$

Speed of a transverse wave on a string

$$v = \sqrt{\frac{T}{\mu}}$$

Intensity of radiation

$$I = \frac{P}{A}$$

Power of a lens

$$P = \frac{1}{f}$$

$$P = P_1 + P_2 + P_3 + \dots$$

Thin lens equation

$$\frac{1}{u} + \frac{1}{v} = \frac{1}{f}$$

Magnification for a lens

$$m = \frac{\text{image height}}{\text{object height}} = \frac{v}{u}$$

Diffraction grating

$$n\lambda = d \sin \theta$$

DO NOT WRITE IN THIS AREA

DO NOT WRITE IN THIS AREA

DO NOT WRITE IN THIS AREA



Refractive index

$$n_1 \sin \theta_1 = n_2 \sin \theta_2$$

$$n = \frac{c}{v}$$

Critical angle

$$\sin C = \frac{1}{n}$$

Photon model

$$E = hf$$

Einstein's photoelectric equation

$$hf = \phi + \frac{1}{2}mv_{\max}^2$$

de Broglie wavelength

$$\lambda = \frac{h}{p}$$

**Further mechanics**Impulse

$$F\Delta t = \Delta p$$

Kinetic energy of a non-relativistic particle

$$E_k = \frac{p^2}{2m}$$

Motion in a circle

$$v = \omega r$$

$$T = \frac{2\pi}{\omega}$$

$$F = ma = \frac{mv^2}{r}$$

$$a = \frac{v^2}{r}$$

$$a = r\omega^2$$

Centripetal force

$$F = \frac{mv^2}{r}$$

$$F = mr\omega^2$$

**Fields**Coulomb's law

$$F = k \frac{Q_1 Q_2}{r^2}$$

$$\text{where } k = \frac{1}{4\pi\epsilon_0}$$

Electric field strength

$$E = \frac{F}{Q}$$

$$E = k \frac{Q}{r^2}$$

$$E = \frac{V}{d}$$

Electric potential

$$V = k \frac{Q}{r}$$

Capacitance

$$C = \frac{Q}{V}$$

Energy stored in a capacitor

$$W = \frac{1}{2}QV$$

Capacitor discharge

$$Q = Q_0 e^{-t/RC}$$

Resistor – capacitor discharge

$$I = I_0 e^{-t/RC}$$

$$V = V_0 e^{-t/RC}$$

In a magnetic field

$$F = BIl \sin \theta$$

$$F = Bqv \sin \theta$$

Faraday's and Lenz's laws

$$\mathcal{E} = \frac{-d(N\phi)}{dt}$$

Root-mean-square values

$$V_{\text{rms}} = \frac{V_0}{\sqrt{2}}$$

$$I_{\text{rms}} = \frac{I_0}{\sqrt{2}}$$



**Nuclear and particle physics**In a magnetic field

$$r = \frac{p}{BQ}$$

**Thermodynamics**Heating

$$\Delta E = mc\Delta\theta$$

$$\Delta E = L\Delta m$$

Molecular kinetic theory

$$\frac{1}{2}m\langle c^2 \rangle = \frac{3}{2}kT$$

$$pV = \frac{1}{3}Nm\langle c^2 \rangle$$

Ideal gas equation

$$pV = NkT$$

Stefan-Boltzmann law

$$L = \sigma AT^4$$

$$L = \sigma 4\pi r^2 T^4$$

Wien's law

$$\lambda_{\max} T = 2.898 \times 10^{-3} \text{ m K}$$

**Space**Intensity

$$I = \frac{L}{4\pi d^2}$$

Redshift of electromagnetic radiation

$$z = \frac{\Delta\lambda}{\lambda} \approx \frac{\Delta f}{f} \approx \frac{v}{c}$$

Cosmological expansion

$$v = H_0 d$$

**Nuclear radiation**Mass-energy

$$\Delta E = c^2 \Delta m$$

Radioactive decay

$$A = \lambda N$$

$$\frac{dN}{dt} = -\lambda N$$

$$\lambda = \frac{\ln 2}{t_{1/2}}$$

$$N = N_0 e^{-\lambda t}$$

$$A = A_0 e^{-\lambda t}$$

**Gravitational fields**Gravitational force

$$F = \frac{Gm_1 m_2}{r^2}$$

Gravitational field strength

$$g = \frac{Gm}{r^2}$$

Gravitational potential

$$V_{\text{grav}} = \frac{-Gm}{r}$$

**Oscillations**Simple harmonic motion

$$F = -kx$$

$$a = -\omega^2 x$$

$$x = A \cos \omega t$$

$$v = -A\omega \sin \omega t$$

$$a = -A\omega^2 \cos \omega t$$

$$T = \frac{1}{f} = \frac{2\pi}{\omega}$$

$$\omega = 2\pi f$$

Simple harmonic oscillator

$$T = 2\pi \sqrt{\frac{m}{k}}$$

$$T = 2\pi \sqrt{\frac{l}{g}}$$

