

Write your name here

Surname	Other names
---------	-------------

Pearson Edexcel
International
Advanced Level

Centre Number	Candidate Number
<input type="text"/>	<input type="text"/>

Physics
Advanced Subsidiary
Unit 2: Physics at Work

Friday 18 May 2018 – Morning Time: 1 hour 30 minutes	Paper Reference WPH02/01
--	------------------------------------

You do not need any other materials.	Total Marks
---	-------------

Instructions

- Use **black** ink or ball-point pen.
- **Fill in the boxes** at the top of this page with your name, centre number and candidate number.
- Answer **all** questions.
- Answer the questions in the spaces provided
– *there may be more space than you need.*

Information

- The total mark for this paper is 80.
- The marks for **each** question are shown in brackets
– *use this as a guide as to how much time to spend on each question.*
- Questions labelled with an **asterisk** (*) are ones where the quality of your written communication will be assessed
– *you should take particular care with your spelling, punctuation and grammar, as well as the clarity of expression, on these questions.*
- The list of data, formulae and relationships is printed at the end of this booklet.
- Candidates may use a scientific calculator.

Advice

- Read each question carefully before you start to answer it.
- Try to answer every question.
- Check your answers if you have time at the end.

Turn over ►

P51634A

©2018 Pearson Education Ltd.

1/1/1/1/1/1/1/



Pearson

SECTION A

Answer ALL questions.

For questions 1–10, in Section A, select one answer from A to D and put a cross in the box . If you change your mind, put a line through the box and then mark your new answer with a cross .

- 1 Two resistors, each of resistance 4Ω , are connected in parallel.

Which of the following is the overall resistance of the combination?

- A $\frac{1}{2}\Omega$
 B 2Ω
 C 4Ω
 D 8Ω

(Total for Question 1 = 1 mark)

- 2 A wave is travelling across the surface of a tank of water. The graph shows how the displacement of the water at one position on the surface varies with time.

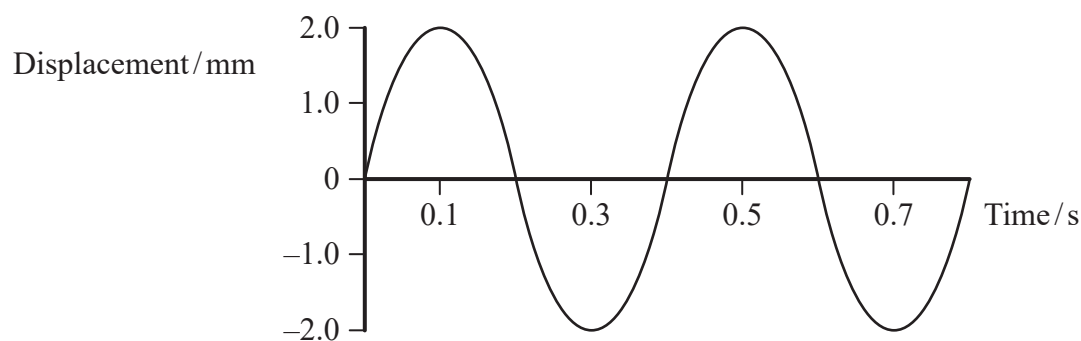

Which property of the wave **cannot** be determined using only the information from this graph?

- A amplitude
 B frequency
 C time period
 D wavelength

(Total for Question 2 = 1 mark)

DO NOT WRITE IN THIS AREA

DO NOT WRITE IN THIS AREA

DO NOT WRITE IN THIS AREA



- 3 A student measures and records four values for the length of a wire.

Length / cm	50.2	49.9	41.1	49.4
-------------	------	------	------	------

Which of the following should be recorded as the mean value of the length in cm?

- A 49.8
- B 50
- C 47.7
- D 48

(Total for Question 3 = 1 mark)

- 4 During a scan of an unborn baby, a series of ultrasound pulses are transmitted through the mother's body and the reflected pulses are detected.

The duration of each ultrasound pulse is kept as small as possible.

Which of the following is the reason for this?

- A So that a large number of pulses can be used.
- B So that a shorter wavelength of ultrasound can be used.
- C To enable more detail to be seen.
- D To keep the energy of the ultrasound to a minimum.

(Total for Question 4 = 1 mark)

DO NOT WRITE IN THIS AREA

DO NOT WRITE IN THIS AREA

DO NOT WRITE IN THIS AREA



- 5 A narrow beam of electrons is passed through a graphite crystal and is then incident on a fluorescent screen. The pattern observed on the screen is shown.

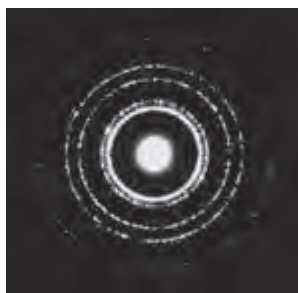

Which of the following conclusions about the electrons can be made from this pattern?

- A The electrons are being attracted to the graphite nuclei.
- B The electrons are being scattered by the graphite nuclei.
- C The electrons are being diffracted by the graphite crystal.
- D The electrons are being refracted by the graphite crystal.

(Total for Question 5 = 1 mark)

- 6 A lamp with an input power of 500 W illuminates a total surface of area 2.0 m². The lamp has an efficiency of 30%.

Which of the following is the radiation flux incident on the surface?

- A 75 W m⁻²
- B 150 W m⁻²
- C 250 W m⁻²
- D 833 W m⁻²

(Total for Question 6 = 1 mark)

DO NOT WRITE IN THIS AREA

DO NOT WRITE IN THIS AREA

DO NOT WRITE IN THIS AREA



- 7 The diagram shows two copper bars, M and N, with square cross-sections as shown.

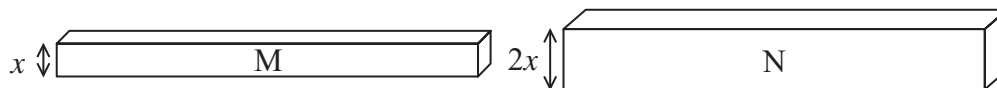

The two bars are connected end to end in series in a circuit. The drift velocity of the electrons in bar M is v .

Which of the following is the drift velocity of the electrons in bar N?

- A $\frac{v}{4}$
- B $\frac{v}{2}$
- C $2v$
- D $4v$

(Total for Question 7 = 1 mark)

DO NOT WRITE IN THIS AREA

DO NOT WRITE IN THIS AREA

DO NOT WRITE IN THIS AREA



Questions 8 and 9 refer to the following experiment.

A lamp is connected to a power supply of potential difference V . The lamp is switched on at time $t = 0$. The graph shows how the current through the lamp varies with time.

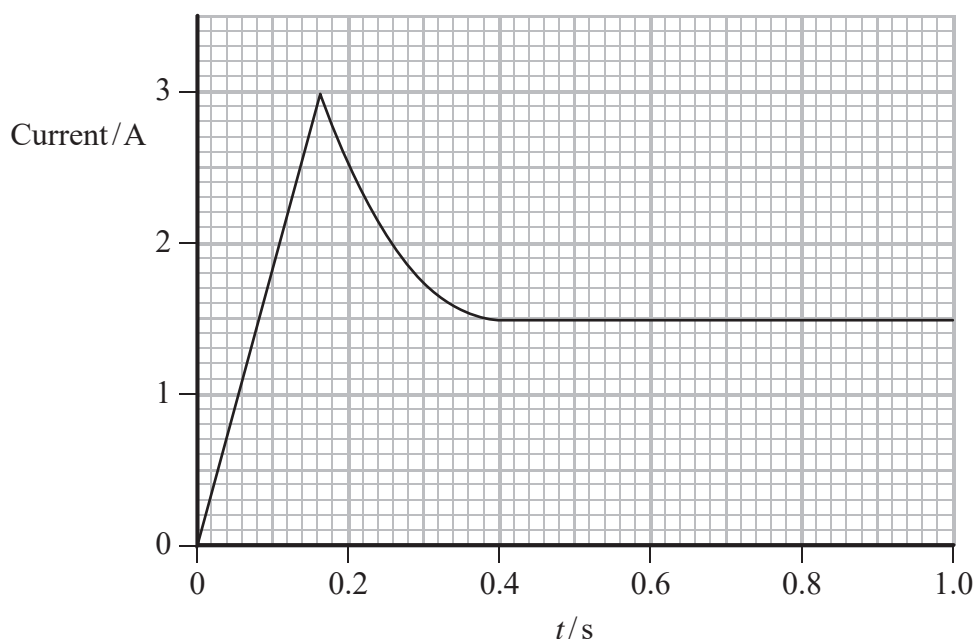

- 8 A data logger is used to measure the current.

Which of the following is the reason for using a data logger in this experiment?

- A it is more precise
- B it can take readings in short time intervals
- C it can take readings over a long length of time
- D it can plot a graph

(Total for Question 8 = 1 mark)

- 9 Which of the following is numerically equal to the work done on the lamp in the first 0.16 s?

- A $V \times (\text{area under graph})$
- B $\frac{(\text{area under graph})}{V}$
- C $V \times (\text{gradient of graph})$
- D $\frac{(\text{gradient of graph})}{V}$

(Total for Question 9 = 1 mark)

DO NOT WRITE IN THIS AREA

DO NOT WRITE IN THIS AREA

DO NOT WRITE IN THIS AREA



10 The temperature of a negative temperature coefficient thermistor is increased.

Which of the following has the greatest impact on the resistance of the thermistor when its temperature is increased?

- A increased kinetic energy of conduction electrons
- B increased lattice vibrations
- C increased number of collisions between conduction electrons and atoms
- D increased number of conduction electrons

(Total for Question 10 = 1 mark)

TOTAL FOR SECTION A = 10 MARKS

DO NOT WRITE IN THIS AREA

DO NOT WRITE IN THIS AREA

DO NOT WRITE IN THIS AREA



SECTION B

Answer ALL questions in the spaces provided.

- 11 A student carried out an investigation using conducting putty. Conducting putty is a material that is a good conductor and can be made into different shapes.

The student formed the conducting putty into cylinders of different sizes. Coins were pushed into the conducting putty at either end so that crocodile clips could be attached to connect the conducting putty into a circuit.

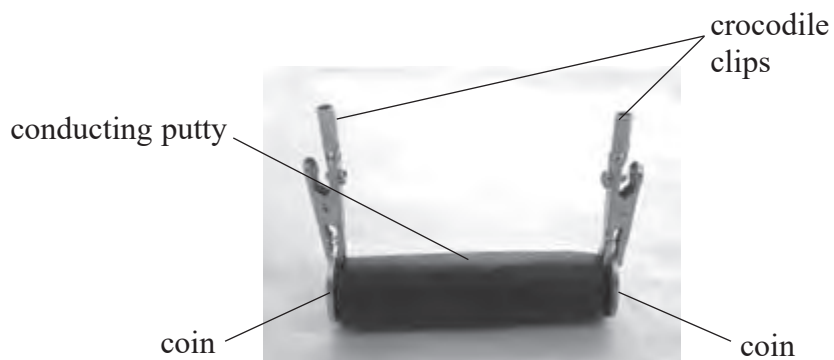

- (a) The student made a cylinder of conducting putty of length 0.075 m and diameter 9.0 mm. Calculate the resistance of the cylinder of conducting putty.

resistivity of conducting putty = $4.2 \times 10^{-2} \Omega \text{m}$

(3)

Resistance =

DO NOT WRITE IN THIS AREA

DO NOT WRITE IN THIS AREA

DO NOT WRITE IN THIS AREA



DO NOT WRITE IN THIS AREA

DO NOT WRITE IN THIS AREA

DO NOT WRITE IN THIS AREA

(b) Two cylinders of conducting putty are connected in parallel across a battery. The cylinders have the same length but different cross-sectional areas.

Explain why the cylinder with the larger cross-sectional area will reach a higher temperature than the other cylinder.

(3)

.....

.....

.....

.....

.....

.....

.....

(Total for Question 11 = 6 marks)



DO NOT WRITE IN THIS AREA

DO NOT WRITE IN THIS AREA

DO NOT WRITE IN THIS AREA

BLANK PAGE



12 Chemists use flame tests to identify the presence of metals in a substance.

The substance is heated in a flame and the resulting colour of the flame is an indication of the metal present.

(a) Some of the energy levels for an atom of a particular metal are shown.

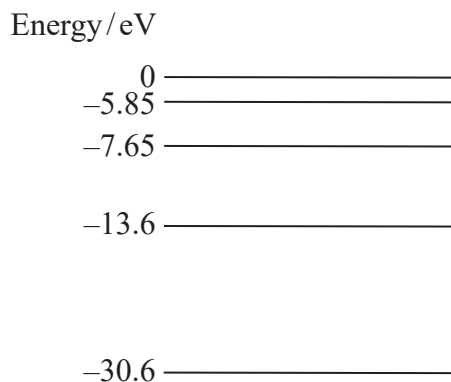

An electron in the atom is excited to the -5.85 eV energy level. The electron then makes the transition to the -7.65 eV energy level.

Calculate the wavelength of the radiation that would be emitted as a result of this transition.

(3)

Wavelength =

(b) Explain why substances containing different metals will produce different colours of flames.

(2)

(Total for Question 12 = 5 marks)



13 Polarising filters are often used when taking photographs outdoors.

Light from the sky is partially plane-polarised. A polarising filter can be placed in front of a camera lens to make the sky appear darker. The intensity of the light transmitted through the polarising filter is reduced, compared to the intensity without the polarising filter, as shown.



(a) Explain what is meant by plane-polarised light.

(2)

.....

.....

.....

.....

DO NOT WRITE IN THIS AREA

DO NOT WRITE IN THIS AREA

DO NOT WRITE IN THIS AREA



- * (b) The light from the sky is transmitted through the polarising filter into the camera. As the polarising filter is rotated, the intensity of the light transmitted through the polarising filter varies as shown.

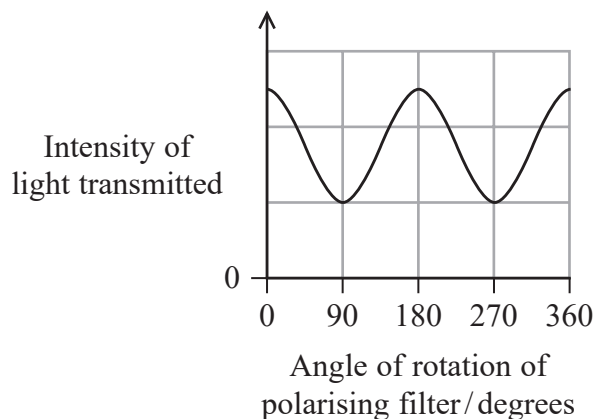

Explain why the intensity of the light transmitted through the polarising filter varies as shown.

(4)

- (c) Suggest why the clouds don't appear to darken as much as the sky when viewed through the polarising filter.

(1)

(Total for Question 13 = 7 marks)



14 The photograph shows an iceberg.



DO NOT WRITE IN THIS AREA

DO NOT WRITE IN THIS AREA

DO NOT WRITE IN THIS AREA

A beam of light from the Sun travels through the top layer of ice and is incident on an air bubble. The diagram shows the path of two rays of light within the beam, ray A and ray B.

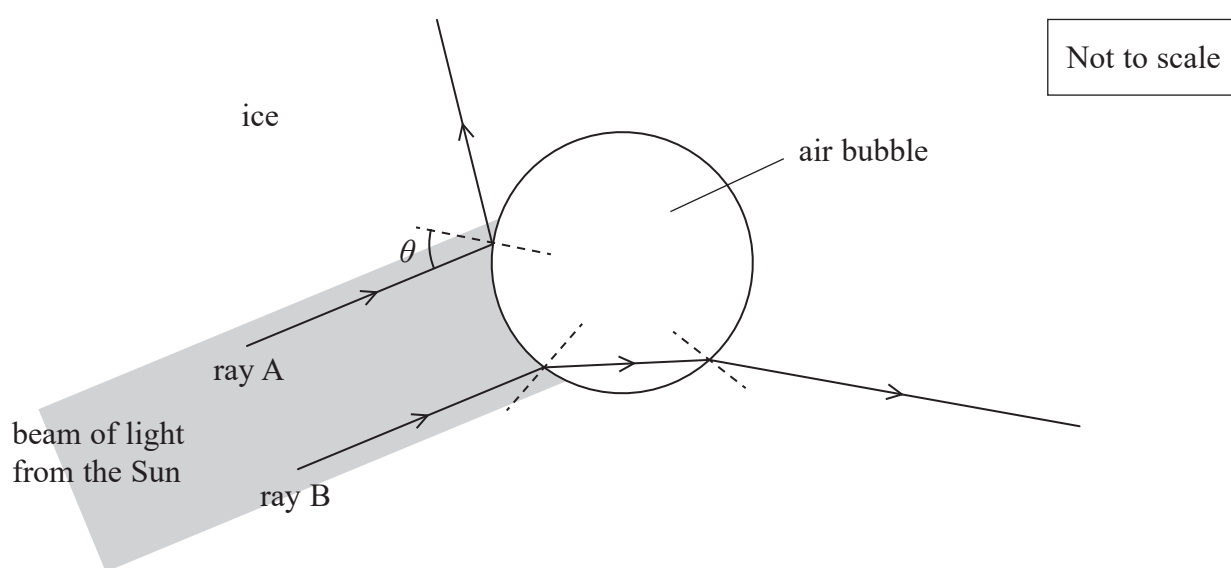

The refractive index of ice is 1.31

(a) Calculate the speed of light in ice.

(2)

.....

.....

.....

.....

Speed of light in ice =



DO NOT WRITE IN THIS AREA

DO NOT WRITE IN THIS AREA

DO NOT WRITE IN THIS AREA

(b) Explain why ray B follows the path shown as it enters the air bubble. (2)

.....

.....

.....

.....

(c) Ray A is totally internally reflected at the surface of the air bubble. Determine the minimum size of the angle θ . (2)

.....

.....

.....

.....

Minimum size of angle $\theta =$

(Total for Question 14 = 6 marks)



- 15 The graph shows how the current I through a filament lamp varies with the potential difference V applied across it.

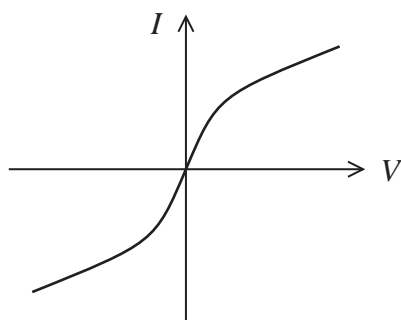

- *(a) Explain the shape of the graph in terms of particle behaviour.

(5)

.....

.....

.....

.....

.....

.....

.....

.....

.....

.....

.....

DO NOT WRITE IN THIS AREA

DO NOT WRITE IN THIS AREA

DO NOT WRITE IN THIS AREA



DO NOT WRITE IN THIS AREA

DO NOT WRITE IN THIS AREA

DO NOT WRITE IN THIS AREA

(b) The current-potential difference graph for a particular filament lamp is shown below.

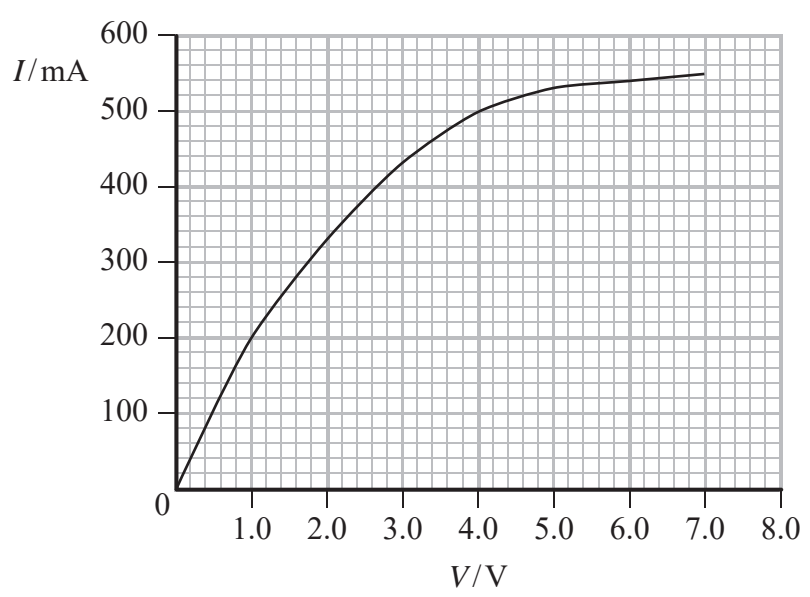

This filament lamp is connected across a battery of e.m.f. 6.0V as shown below.

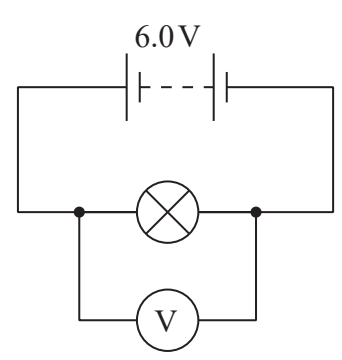

The voltmeter reading is 4.2V.

Determine the internal resistance of the battery.

(3)

.....

.....

.....

.....

.....

.....

Internal resistance =

(Total for Question 15 = 8 marks)



16 The quality of the sound heard by listeners at a concert depends on the design of the concert hall.

- (a) Two loudspeakers, S_1 and S_2 , are connected to the same source. They are placed a small distance apart in a concert hall. The loudness of the sound heard from the speakers varies throughout the concert hall.

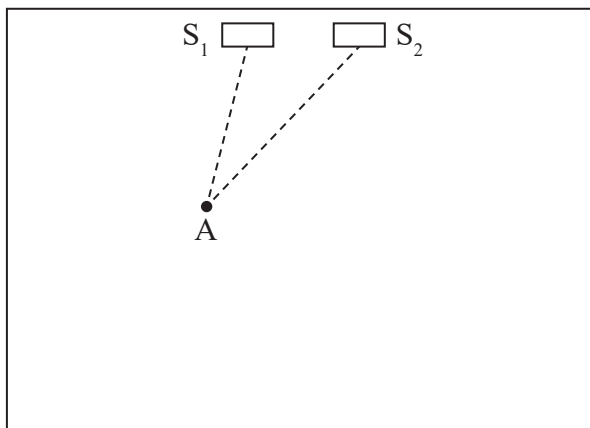

Point A is 3.10 m from S_1 and 4.00 m from S_2 .

S_1 and S_2 emit a sound of frequency 567 Hz.

Explain why the sound heard at A will be quiet. Your answer should include a calculation.

(4)

speed of sound in air = 340 m s^{-1}

.....

.....

.....

.....

.....

.....

.....

.....

.....

.....

DO NOT WRITE IN THIS AREA

DO NOT WRITE IN THIS AREA

DO NOT WRITE IN THIS AREA



DO NOT WRITE IN THIS AREA

DO NOT WRITE IN THIS AREA

DO NOT WRITE IN THIS AREA

(b) The formation of standing waves within the concert hall may also create points where the sound heard is loud or quiet. Two methods used to prevent the formation of standing waves are using soft fabrics on the walls or using tiles placed on the walls at varying angles.

Suggest how each of these two methods reduces the formation of standing waves.

(3)

.....

.....

.....

.....

.....

.....

.....

(Total for Question 16 = 7 marks)



- 17 The photograph shows a new design of car that can travel with minimal operation from the driver compared to a conventional car.



DO NOT WRITE IN THIS AREA

DO NOT WRITE IN THIS AREA

DO NOT WRITE IN THIS AREA

The new car contains systems to detect other vehicles. One system uses a pulse-echo technique with laser light and another system uses the Doppler effect with microwaves.

- (a) One of these new cars travels behind a truck. Both vehicles are travelling at the same speed.

Pulses of laser light are transmitted from the new car and the time taken for each reflected pulse to return is measured.

The time between a pulse being transmitted and returning is measured to be 2.6×10^{-7} s.

Calculate the distance between the new car and the truck.

(3)

.....

.....

.....

.....

.....

.....

.....

Distance =



DO NOT WRITE IN THIS AREA

DO NOT WRITE IN THIS AREA

DO NOT WRITE IN THIS AREA

(b) The speed of the truck decreases.

(i) Explain how the new car uses the Doppler effect with microwaves to detect that the speed of the truck has decreased.

(3)

.....

.....

.....

.....

.....

.....

.....

(ii) The new car automatically applies the brakes when it detects that the speed of the truck has decreased.

Explain why the introduction of the new car may reduce road traffic accidents.

(3)

.....

.....

.....

.....

.....

.....

.....

(Total for Question 17 = 9 marks)



18 (a) A 9.0V battery of negligible internal resistance is connected as shown.

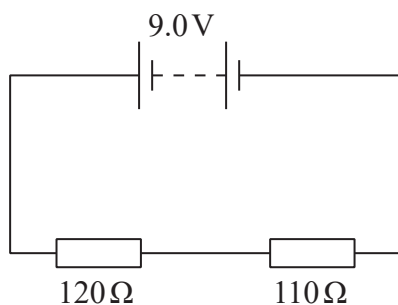

(i) Calculate the potential difference (p.d.) across the $120\ \Omega$ resistor.

(2)

p.d. =

(ii) A student added to the circuit, as shown below, in order to determine the resistance R of a resistor.

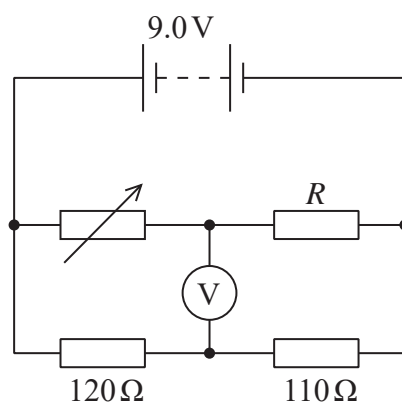

As the student adjusted the variable resistor, the reading on the voltmeter changed. When the variable resistor had a resistance of $295\ \Omega$, the reading on the voltmeter was $0\ \text{V}$. This happened because the p.d. across the variable resistor was equal to the p.d. across the $120\ \Omega$ resistor.

Show that the value of R is about $300\ \Omega$.

(2)

DO NOT WRITE IN THIS AREA

DO NOT WRITE IN THIS AREA

DO NOT WRITE IN THIS AREA



DO NOT WRITE IN THIS AREA

(b) A different form of the circuit is shown below. The $120\ \Omega$ and $110\ \Omega$ resistors were replaced with a wire XY of length 1.000 m. R is $300\ \Omega$ and the variable resistor was altered to a different value.

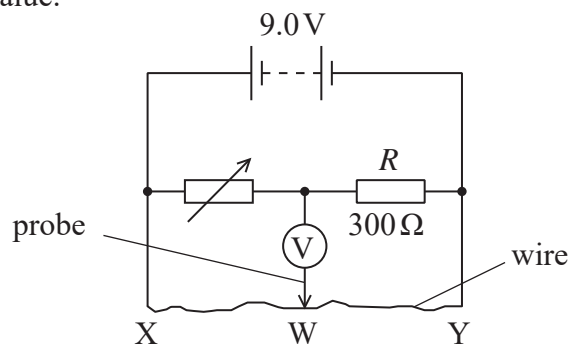

(i) The student moved the probe attached to the voltmeter along the wire until, at W, the reading on the voltmeter was 0 V. This occurred when the length XW was 33.0 cm.

Calculate the resistance of the variable resistor, assuming that the wire XY has a uniform cross-sectional area.

(2)

Resistance of the variable resistor =

(ii) The student discovered that the wire was thinner between X and W than it was between W and Y.

Explain why this results in an error in the calculated value of the resistance of the variable resistor.

(2)

(iii) Describe how the student could check that the diameter of the wire is uniform.

(3)

DO NOT WRITE IN THIS AREA

DO NOT WRITE IN THIS AREA

(Total for Question 18 = 11 marks)



- 19 A gold leaf electroscope is a device that can be used to detect charge. The deflection of the gold leaf depends on the amount of charge on the zinc plate and the conducting rod.

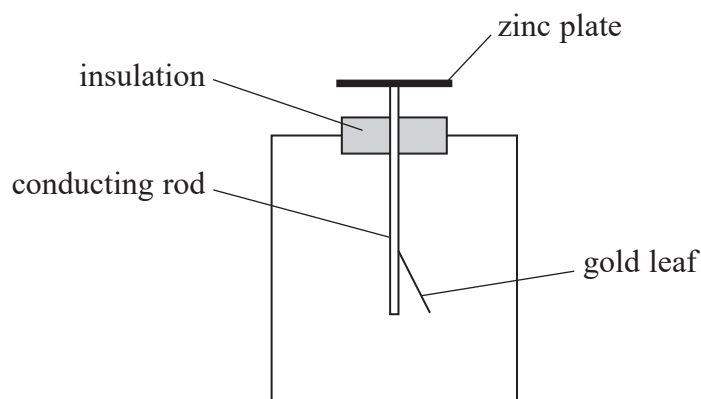

In a demonstration of the photoelectric effect, a teacher charged the zinc plate with a negative charge and the gold leaf was deflected.

When ultraviolet radiation of frequency 2.0×10^{15} Hz was shone onto the zinc plate, the deflection of the gold leaf reduced.

- (a) (i) Explain why the deflection of the gold leaf reduced. Your answer should include a calculation.

(4)

work function for zinc = 6.9×10^{-19} J

.....

.....

.....

.....

.....

.....

DO NOT WRITE IN THIS AREA

DO NOT WRITE IN THIS AREA

DO NOT WRITE IN THIS AREA



(ii) Explain what would be observed with the gold leaf electroscope if ultraviolet radiation of the same frequency but with a lower intensity was used.

(4)

.....

.....

.....

.....

.....

.....

.....

.....

(b) In the early 20th century, the wave model was generally accepted as an explanation of the nature of light.

Explain why the wave model cannot explain the photoelectric effect.

(3)

.....

.....

.....

.....

.....

.....

.....

.....

.....

(Total for Question 19 = 11 marks)

TOTAL FOR SECTION B = 70 MARKS
TOTAL FOR PAPER = 80 MARKS

DO NOT WRITE IN THIS AREA

DO NOT WRITE IN THIS AREA

DO NOT WRITE IN THIS AREA



DO NOT WRITE IN THIS AREA

DO NOT WRITE IN THIS AREA

DO NOT WRITE IN THIS AREA

BLANK PAGE



List of data, formulae and relationships

Acceleration of free fall	$g = 9.81 \text{ m s}^{-2}$	(close to Earth's surface)
Electron charge	$e = -1.60 \times 10^{-19} \text{ C}$	
Electron mass	$m_e = 9.11 \times 10^{-31} \text{ kg}$	
Electronvolt	$1 \text{ eV} = 1.60 \times 10^{-19} \text{ J}$	
Gravitational field strength	$g = 9.81 \text{ N kg}^{-1}$	(close to Earth's surface)
Planck constant	$h = 6.63 \times 10^{-34} \text{ J s}$	
Speed of light in a vacuum	$c = 3.00 \times 10^8 \text{ m s}^{-1}$	

Unit 1

Mechanics

Kinematic equations of motion	$v = u + at$
	$s = ut + \frac{1}{2}at^2$
	$v^2 = u^2 + 2as$

Forces	$\Sigma F = ma$
	$g = F/m$
	$W = mg$

Work and energy	$\Delta W = F\Delta s$
	$E_k = \frac{1}{2}mv^2$
	$\Delta E_{\text{grav}} = mg\Delta h$

Materials

Stokes' law	$F = 6\pi\eta rv$
-------------	-------------------

Hooke's law	$F = k\Delta x$
-------------	-----------------

Density	$\rho = m/V$
---------	--------------

Pressure	$p = F/A$
----------	-----------

Young modulus	$E = \sigma/\epsilon$ where
	Stress $\sigma = F/A$
	Strain $\epsilon = \Delta x/x$

Elastic strain energy	$E_{\text{el}} = \frac{1}{2}F\Delta x$
-----------------------	--

DO NOT WRITE IN THIS AREA

DO NOT WRITE IN THIS AREA

DO NOT WRITE IN THIS AREA



Unit 2*Waves*

Wave speed $v = f\lambda$

Refractive index ${}_1\mu_2 = \sin i / \sin r = v_1 / v_2$

Electricity

Potential difference $V = W/Q$

Resistance $R = V/I$

Electrical power, energy and efficiency
 $P = VI$
 $P = I^2R$
 $P = V^2/R$
 $W = VI t$

$$\% \text{ efficiency} = \frac{\text{useful energy output}}{\text{total energy input}} \times 100$$

$$\% \text{ efficiency} = \frac{\text{useful power output}}{\text{total power input}} \times 100$$

Resistivity $R = \rho l/A$

Current
 $I = \Delta Q / \Delta t$
 $I = nqvA$

Resistors in series $R = R_1 + R_2 + R_3$

Resistors in parallel
 $\frac{1}{R} = \frac{1}{R_1} + \frac{1}{R_2} + \frac{1}{R_3}$

Quantum physics

Photon model $E = hf$

Einstein's photoelectric equation
 $hf = \phi + \frac{1}{2}mv_{\max}^2$

DO NOT WRITE IN THIS AREA

DO NOT WRITE IN THIS AREA

DO NOT WRITE IN THIS AREA

