

Please check the examination details below before entering your candidate information

Candidate surname

Other names

**Pearson Edexcel**  
**International**  
**Advanced Level**

Centre Number

--	--	--	--	--

Candidate Number

--	--	--	--

**Thursday 10 January 2019**

Morning (Time: 1 hour 30 minutes)

Paper Reference **WPH11/01**

**Physics**

**International Advanced Subsidiary**

**Unit 1: Mechanics and Materials**

**You must have:**

Scientific calculator, ruler, protractor

Total Marks

### Instructions

- Use **black** ink or **black** ball-point pen.
- **Fill in the boxes** at the top of this page with your name, centre number and candidate number.
- Answer **all** questions.
- Answer the questions in the spaces provided  
– *there may be more space than you need.*
- **Show all your working in calculations and include units where appropriate.**

### Information

- The total mark for this paper is 80.
- The marks for **each** question are shown in brackets  
– *use this as a guide as to how much time to spend on each question.*
- In questions marked with an **asterisk** (\*), marks will be awarded for your ability to structure your answer logically showing how the points that you make are related or follow on from each other where appropriate.

### Advice

- Read each question carefully before you start to answer it.
- Try to answer every question.
- Check your answers if you have time at the end.

Turn over ►

P60790RA

©2019 Pearson Education Ltd.

1/1/1/1/1/1/1/1/1/1/



P 6 0 7 9 0 R A 0 1 2 8



Pearson

**SECTION A**

**Answer ALL questions.**

**For questions 1–10, select one answer from A to D and put a cross in the box ☒.  
If you change your mind, put a line through the box ☒ and then  
mark your new answer with a cross ☒.**

**1** Which of the following is a vector quantity?

- A** work done
- B** time
- C** temperature
- D** displacement

**(Total for Question 1 = 1 mark)**

**2** Which of the following is equivalent to 1 kilowatt-hour?

- A** 0.28 J
- B** 0.28 W
- C**  $3.6 \times 10^6$  J
- D**  $3.6 \times 10^6$  W

**(Total for Question 2 = 1 mark)**

**3** Stokes' law can be used to determine the frictional force on an object moving through a fluid.

To which of the following would Stokes' law best apply?

- A** A large sphere moving quickly through a fluid.
- B** A large sphere moving slowly through a fluid.
- C** A small sphere moving quickly through a fluid.
- D** A small sphere moving slowly through a fluid.

**(Total for Question 3 = 1 mark)**

DO NOT WRITE IN THIS AREA

DO NOT WRITE IN THIS AREA

DO NOT WRITE IN THIS AREA

DO NOT WRITE IN THIS AREA

DO NOT WRITE IN THIS AREA

DO NOT WRITE IN THIS AREA



- 4 A force of 90 N is used to push a box along a ramp of length 10 m, up to a platform. The platform is 4 m above the ground. The weight of the box is 200 N.

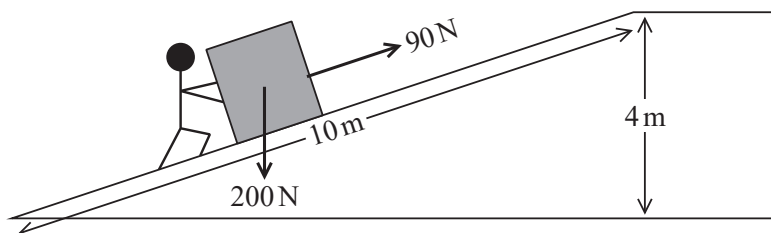

Which of the following expressions could be used to determine the efficiency of the ramp?

- A  $\frac{90 \times 10}{200 \times 4}$
- B  $\frac{200 \times 4}{(90 \times 10) + (200 \times 4)}$
- C  $\frac{200 \times 4}{90 \times 10}$
- D  $\frac{90 \times 10}{(90 \times 10) + (200 \times 4)}$

(Total for Question 4 = 1 mark)

- 5 According to Newton's third law, when two objects interact they exert forces on each other.

Which of the following statements is **not** a correct description of these forces?

- A The forces act at the same time.
- B The forces act in the same direction.
- C The forces act on different objects.
- D The forces have the same magnitude.

(Total for Question 5 = 1 mark)



6 A ball is thrown vertically upwards.

Which row of the table correctly describes the magnitude of the initial acceleration of the ball and the magnitude of the acceleration when it is at its maximum height?

	Initial acceleration	Acceleration at maximum height
<input type="checkbox"/> A	0	$9.81 \text{ m s}^{-2}$
<input type="checkbox"/> B	$9.81 \text{ m s}^{-2}$	0
<input type="checkbox"/> C	$9.81 \text{ m s}^{-2}$	$9.81 \text{ m s}^{-2}$
<input type="checkbox"/> D	0	0

(Total for Question 6 = 1 mark)

7 One end of a 50 cm length of wire is attached to a support. A load is attached to the free end of the wire, which extends by 2 mm.

Which of the following is the strain for the length of wire?

- A 0.004
- B 0.04
- C 25
- D 250

(Total for Question 7 = 1 mark)

DO NOT WRITE IN THIS AREA

DO NOT WRITE IN THIS AREA

DO NOT WRITE IN THIS AREA

DO NOT WRITE IN THIS AREA

DO NOT WRITE IN THIS AREA

DO NOT WRITE IN THIS AREA



8 A ball is dropped, bounces once and is then caught.

Which of the following graphs of gravitational potential energy  $E_{\text{grav}}$  against time  $t$  could represent the motion of the ball?

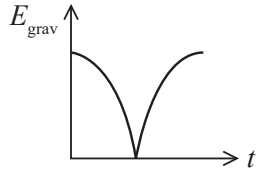

A

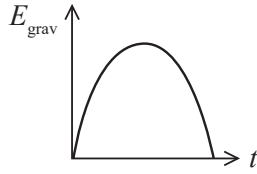

B

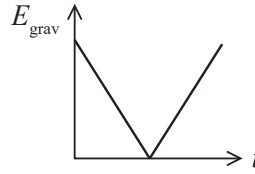

C

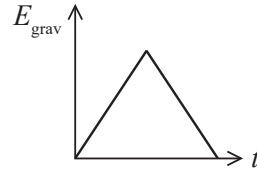

D

(Total for Question 8 = 1 mark)

9 The stiffness constant and the Young modulus are terms used in physics.

Which row of the table shows the correct application of these terms?

	Stiffness constant applies to	Young modulus applies to
<input type="checkbox"/> A	materials	materials
<input type="checkbox"/> B	objects	objects
<input type="checkbox"/> C	materials	objects
<input type="checkbox"/> D	objects	materials

(Total for Question 9 = 1 mark)



10 A student used a balance to measure the mass of a small cube with sides of length  $x$ .

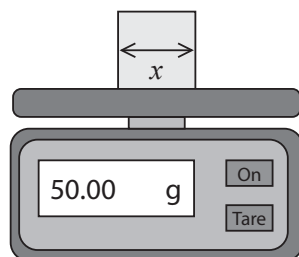

The student also measured the mass of a larger cube with sides of length  $1.5x$ .

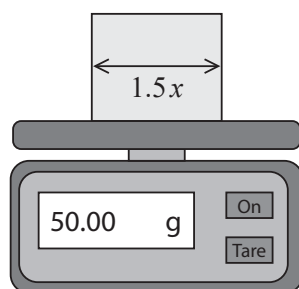

Which of the following is the density  $\rho_L$  of the larger cube in terms of the density  $\rho_S$  of the smaller cube?

- A  $\rho_L = 3.4\rho_S$
- B  $\rho_L = 1.5\rho_S$
- C  $\rho_L = 0.67\rho_S$
- D  $\rho_L = 0.30\rho_S$

(Total for Question 10 = 1 mark)

TOTAL FOR SECTION A = 10 MARKS



SECTION B

Answer ALL questions in the spaces provided.

11 The graph shows how the velocity of an object varies with time.

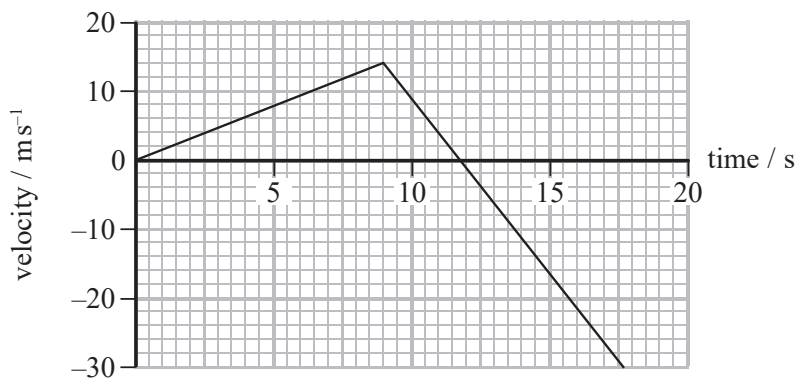

Describe how the acceleration of the object varies with time.  
Your answer should include calculations.

(3)

(Total for Question 11 = 3 marks)



- 12 A student carries out an experiment to determine a value for  $g$ , the acceleration of free fall. A short wooden rod is released above a light gate. A timer connected to the light gate is used to measure the time taken for the wooden rod to pass through the light gate.

The experimental arrangement is shown.

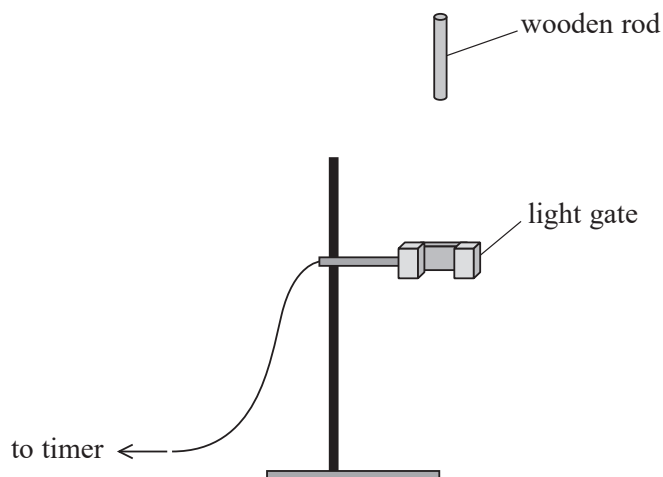

The student uses the equation  $v^2 = u^2 + 2as$ , where  $u = 0$ , and a graphical method to determine a value for  $g$ .

- (a) State the additional measurements the student should take.

(2)

.....

.....

.....

.....

- (b) Describe how the velocity  $v$  of the wooden rod as it passes through the light gate can be determined accurately.

(2)

.....

.....

.....

.....

.....

DO NOT WRITE IN THIS AREA

DO NOT WRITE IN THIS AREA

DO NOT WRITE IN THIS AREA

DO NOT WRITE IN THIS AREA

DO NOT WRITE IN THIS AREA

DO NOT WRITE IN THIS AREA





(c) Describe how the student can determine a value for  $g$  using a graphical method.

(3)

Area for student response with horizontal dotted lines.

(Total for Question 12 = 7 marks)

DO NOT WRITE IN THIS AREA

DO NOT WRITE IN THIS AREA

DO NOT WRITE IN THIS AREA

DO NOT WRITE IN THIS AREA

DO NOT WRITE IN THIS AREA

DO NOT WRITE IN THIS AREA



- 13 Two brackets, A and B, support a shelf of length 1.2 m. Bracket A is positioned 0.15 m from the left-hand end of the shelf. A book is placed 0.35 m from the left-hand end of the shelf as shown.



- (a) The normal contact forces of each bracket on the shelf are equal.

Determine the distance of bracket B from the left-hand end of the shelf.

weight of book = 8.5 N

weight of shelf = 14 N

(5)

.....

.....

.....

.....

.....

.....

.....

.....

.....

.....

.....

.....

.....

.....

.....

.....

.....

.....

.....

.....

Distance = .....



(b) Bracket B is moved closer to the left-hand end of the shelf.

Explain the effect on the magnitude of the normal contact force of bracket B on the shelf.

(2)

.....

.....

.....

.....

.....

.....

.....

.....

**(Total for Question 13 = 7 marks)**

DO NOT WRITE IN THIS AREA

DO NOT WRITE IN THIS AREA

DO NOT WRITE IN THIS AREA

DO NOT WRITE IN THIS AREA

DO NOT WRITE IN THIS AREA

DO NOT WRITE IN THIS AREA



\*14 The approximate age of an egg can be determined by placing it in a bowl of water. Two eggs of different ages are placed in water and come to rest as shown.

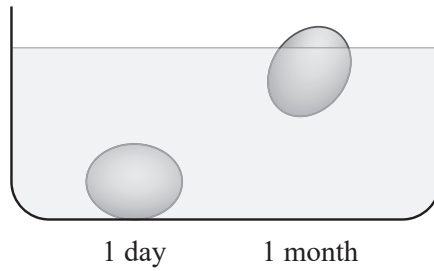

The internal structure of an egg is shown below.

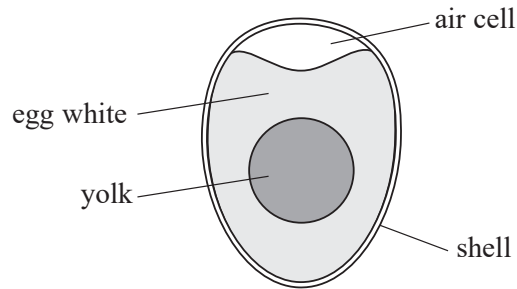

A student searched on the internet to find the reason why old eggs float.

He found the following statements on different websites.

Statement 1

Old eggs float because as the egg ages it starts to decompose. As it decomposes gases are produced that escape through the eggshell.

Statement 2

As the egg ages, air enters the egg through the eggshell and increases the size of the air cell. The larger air cell acts as a flotation device and hence old eggs float.

DO NOT WRITE IN THIS AREA

DO NOT WRITE IN THIS AREA

DO NOT WRITE IN THIS AREA

DO NOT WRITE IN THIS AREA

DO NOT WRITE IN THIS AREA

DO NOT WRITE IN THIS AREA



Assess which of these two statements is correct.

(6)

Area with horizontal dotted lines for writing the answer.

(Total for Question 14 = 6 marks)

DO NOT WRITE IN THIS AREA

DO NOT WRITE IN THIS AREA

DO NOT WRITE IN THIS AREA

DO NOT WRITE IN THIS AREA

DO NOT WRITE IN THIS AREA

DO NOT WRITE IN THIS AREA



P 6 0 7 9 0 R A 0 1 3 2 8

15 P and Q are identical spheres. Sphere P moves along a smooth horizontal surface and collides with sphere Q, which is initially stationary.

After the collision:

- sphere P moves off with a momentum of  $0.096 \text{ kg m s}^{-1}$  in a direction of  $15^\circ$  to its initial direction.
- sphere Q moves off with a momentum of  $0.14 \text{ kg m s}^{-1}$  in a direction of  $10^\circ$  as shown.

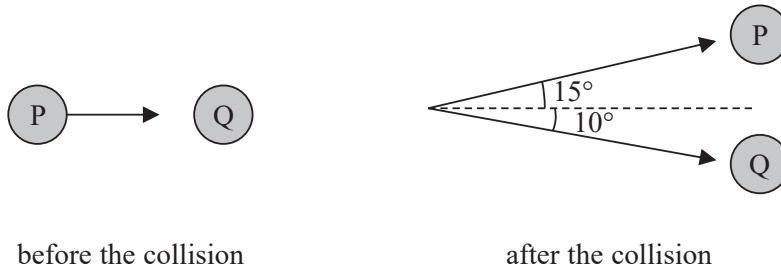

(a) Use a scaled vector diagram to show that the magnitude of the total momentum of spheres P and Q after the collision is about  $0.2 \text{ kg m s}^{-1}$ .

(4)

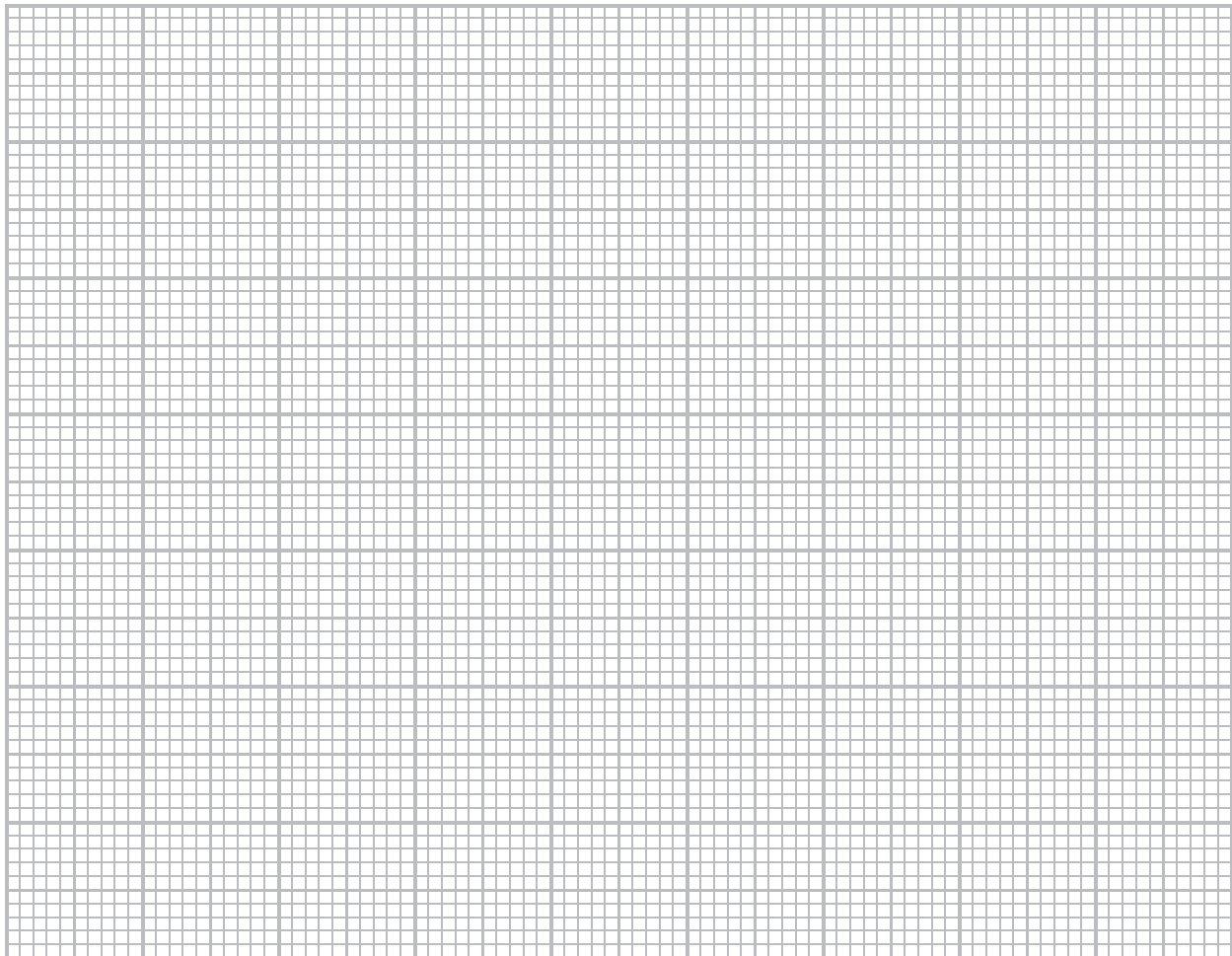

Total momentum of spheres P and Q after the collision = .....



(b) State the principle of conservation of linear momentum.

(2)

.....

.....

.....

.....

(c) Calculate the initial velocity of sphere P.

mass of sphere P = 0.12 kg

(2)

.....

.....

.....

.....

Initial velocity of sphere P = .....

**(Total for Question 15 = 8 marks)**

---

.....

.....

.....

.....

.....

DO NOT WRITE IN THIS AREA

DO NOT WRITE IN THIS AREA

DO NOT WRITE IN THIS AREA

DO NOT WRITE IN THIS AREA

DO NOT WRITE IN THIS AREA

DO NOT WRITE IN THIS AREA



P 6 0 7 9 0 R A 0 1 5 2 8

16 In 2016, the European Space Agency sent the Schiaparelli probe to Mars.

As the probe approached the surface of Mars, with a vertical velocity component of  $460 \text{ m s}^{-1}$ , a parachute was opened to reduce the speed of the probe. Once the vertical velocity of the probe had reduced to  $75 \text{ m s}^{-1}$ , the parachute was removed and the thrusters were switched on.

Due to an error the thrusters were switched off too soon, leaving the probe to ‘free fall’ to the surface of Mars.

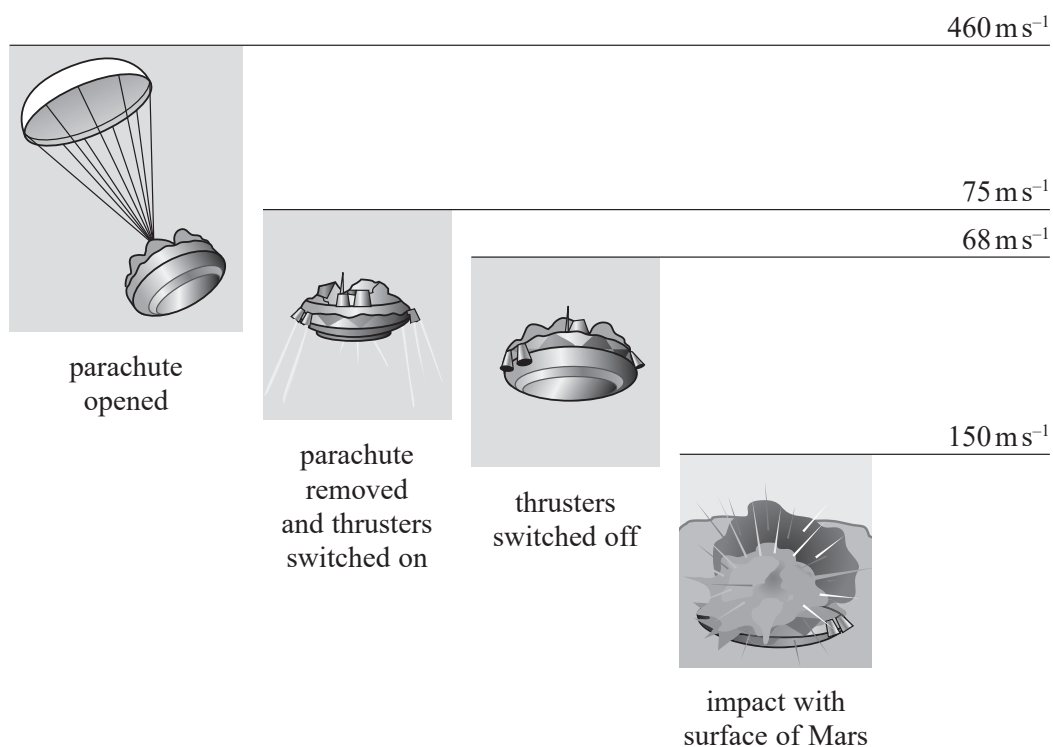

(a) The parachute was used over a decrease in height of  $9.7 \text{ km}$ .

(i) Show that the average vertical deceleration of the probe due to the parachute was about  $11 \text{ m s}^{-2}$ .

(2)

.....

.....

.....

.....

.....

.....

.....





(ii) The parachute was at an angle to the vertical as shown.



Not to scale

The total resistive force acting on the parachute and probe was at an average angle of  $6^\circ$  to the vertical.

Calculate the magnitude of the average total resistive force. You may neglect the mass of the parachute.

mass of probe = 600 kg

gravitational field strength on Mars =  $3.8 \text{ N kg}^{-1}$

(3)

.....

.....

.....

.....

.....

.....

Average total resistive force = .....



- (b) The probe was in 'free fall' from a height of 3.7 km, reaching the surface of Mars with a velocity of  $150\text{ m s}^{-1}$ .

Explain whether the term 'free fall' is correct in this context.  
Your answer should include a calculation.

gravitational field strength on Mars =  $3.8\text{ N kg}^{-1}$

(6)

---

---

---

---

---

---

---

---

---

---

---

---

---

---

---

---

---

---

---

---

---

---

---

---

**(Total for Question 16 = 11 marks)**

DO NOT WRITE IN THIS AREA

DO NOT WRITE IN THIS AREA

DO NOT WRITE IN THIS AREA

DO NOT WRITE IN THIS AREA

DO NOT WRITE IN THIS AREA

DO NOT WRITE IN THIS AREA



DO NOT WRITE IN THIS AREA

DO NOT WRITE IN THIS AREA

DO NOT WRITE IN THIS AREA

DO NOT WRITE IN THIS AREA

DO NOT WRITE IN THIS AREA

DO NOT WRITE IN THIS AREA

**BLANK PAGE**



17 When concrete is first made it has a high moisture content. As the concrete dries its properties change.

A manufacturer of concrete carried out compression testing of cylindrical samples of concrete using the equipment shown.

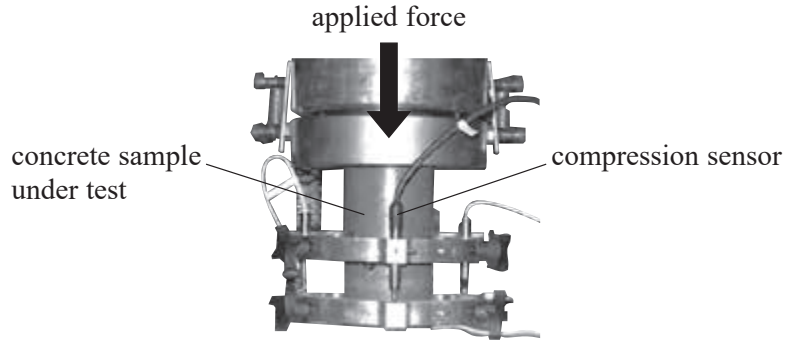

The diagram shows stress-strain graphs, up to the fracture point, for concrete samples 2 days and 28 days after being made.

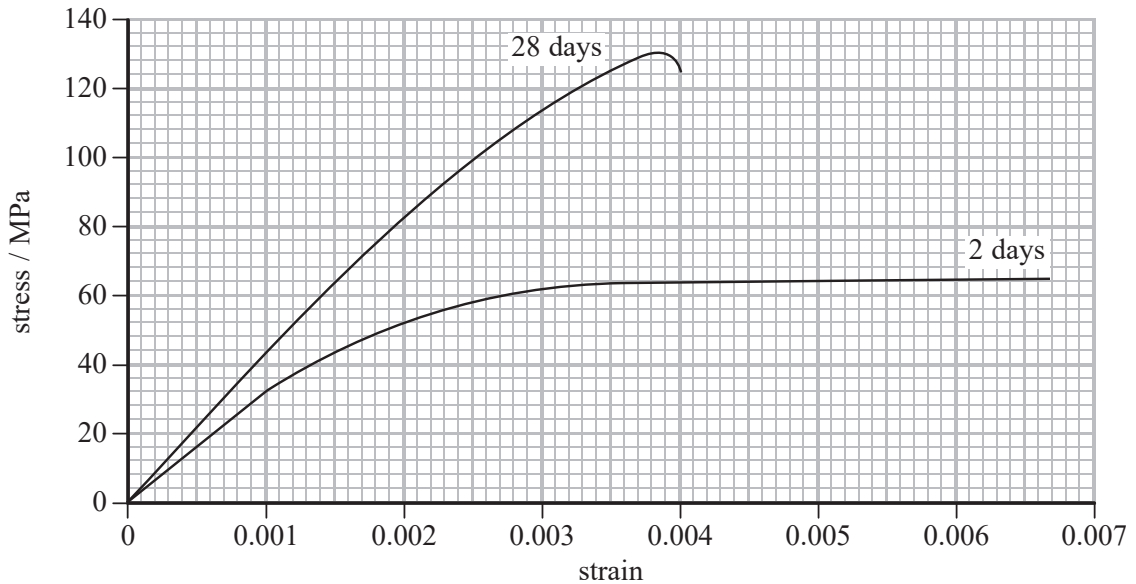

(a) As the concrete dries its Young modulus increases.

Show that the value for the Young modulus of the concrete after it has dried is at least 1.3 times greater.

(4)

.....

.....

.....

.....

.....

.....

.....

.....



- (b) The energy absorbed before fracture by the 28-day old sample is less than the energy absorbed before fracture by the 2-day old sample.

The area under a stress-strain graph gives the energy absorbed per unit volume of the sample.

The energy absorbed before fracture by the 2-day old sample is  $0.35 \text{ MJ m}^{-3}$ .

Determine the percentage reduction in the energy absorbed before fracture between the 2-day old and the 28-day old samples.

You may assume that the volumes of the cylindrical samples are the same.

(3)

.....

.....

.....

.....

.....

.....

.....

.....

.....

.....

- (c) Manufacturers recommend leaving concrete blocks to dry for at least 28 days before use.

Discuss why.

(3)

.....

.....

.....

.....

.....

.....

.....

.....

.....

.....

(Total for Question 17 = 10 marks)



P 6 0 7 9 0 R A 0 2 1 2 8

DO NOT WRITE IN THIS AREA

DO NOT WRITE IN THIS AREA

DO NOT WRITE IN THIS AREA

DO NOT WRITE IN THIS AREA

DO NOT WRITE IN THIS AREA

DO NOT WRITE IN THIS AREA

- 18 The luge is an event at the Winter Olympics. An athlete lies on a small sledge and races down an icy track, feet first.



Source: www.wtop.com

- (a) An athlete accelerates down a straight section of the track as shown. The track is at an angle  $\theta$  to the horizontal.

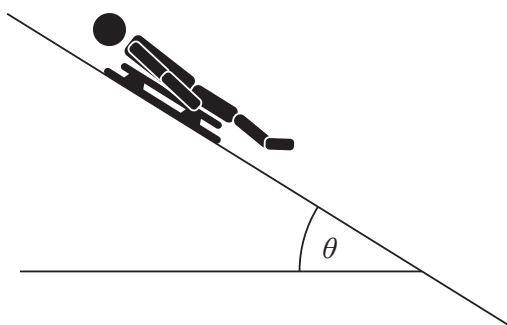

Draw a free-body force diagram for the sledge and athlete.  
You should consider the relative sizes of the forces when drawing your diagram.

(4)

DO NOT WRITE IN THIS AREA

DO NOT WRITE IN THIS AREA

DO NOT WRITE IN THIS AREA

DO NOT WRITE IN THIS AREA

DO NOT WRITE IN THIS AREA

DO NOT WRITE IN THIS AREA



(b) The mass of the athlete is one of the factors that affects her time to complete the race.

(i) Explain why the mass of the athlete has little effect on the initial acceleration. (3)

.....

.....

.....

.....

.....

.....

(ii) Explain, in terms of forces, why the athlete reaches a maximum velocity. (3)

.....

.....

.....

.....

.....

.....

.....

.....

(iii) It is stated that the maximum speed is greater for athletes of greater mass.  
Suggest why this is only correct up to a certain mass. (2)

.....

.....

.....

.....

.....

.....

DO NOT WRITE IN THIS AREA

DO NOT WRITE IN THIS AREA

DO NOT WRITE IN THIS AREA

DO NOT WRITE IN THIS AREA

DO NOT WRITE IN THIS AREA

DO NOT WRITE IN THIS AREA



- (c) After the finish line there is a straight, uphill section of track for the sledge to decelerate in. The maximum permitted gradient of this section is 20%.

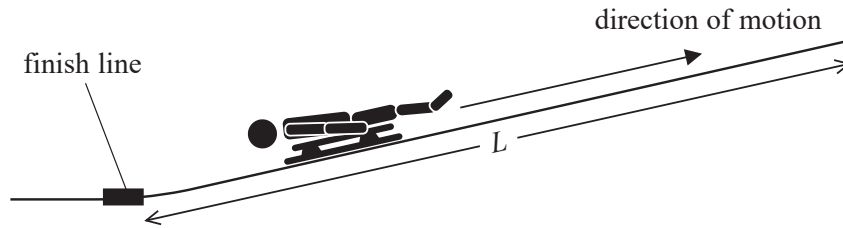

- (i) Show that a track with a gradient of 20% is at an angle to the horizontal of about  $11^\circ$ . (1)

- (ii) An athlete reaches the finish line at a velocity of  $33 \text{ m s}^{-1}$ . She then applies a minimum braking force of  $240 \text{ N}$  as she moves along the uphill section of track to help her come to a stop.

Calculate the minimum uphill length of track  $L$  that should be available for braking. You should ignore all frictional forces other than those applied by the athlete.

mass of sledge and athlete =  $95 \text{ kg}$

(5)

$L = \dots\dots\dots$

(Total for Question 18 = 18 marks)

**TOTAL FOR SECTION B = 70 MARKS**  
**TOTAL FOR PAPER = 80 MARKS**





DO NOT WRITE IN THIS AREA

DO NOT WRITE IN THIS AREA

DO NOT WRITE IN THIS AREA

DO NOT WRITE IN THIS AREA

DO NOT WRITE IN THIS AREA

DO NOT WRITE IN THIS AREA

**BLANK PAGE**



P 6 0 7 9 0 R A 0 2 5 2 8

DO NOT WRITE IN THIS AREA

DO NOT WRITE IN THIS AREA

DO NOT WRITE IN THIS AREA

DO NOT WRITE IN THIS AREA

DO NOT WRITE IN THIS AREA

DO NOT WRITE IN THIS AREA

**BLANK PAGE**



DO NOT WRITE IN THIS AREA

DO NOT WRITE IN THIS AREA

DO NOT WRITE IN THIS AREA

DO NOT WRITE IN THIS AREA

DO NOT WRITE IN THIS AREA

DO NOT WRITE IN THIS AREA

**BLANK PAGE**



P 6 0 7 9 0 R A 0 2 7 2 8

### List of data, formulae and relationships

Acceleration of free fall	$g = 9.81 \text{ m s}^{-2}$	(close to Earth's surface)
Gravitational field strength	$g = 9.81 \text{ N kg}^{-1}$	(close to Earth's surface)

#### Unit 1

##### Mechanics

Kinematic equations of motion	$s = \frac{(u + v)t}{2}$
	$v = u + at$
	$s = ut + \frac{1}{2}at^2$
	$v^2 = u^2 + 2as$

Forces	$\Sigma F = ma$
	$g = \frac{F}{m}$
	$W = mg$

Momentum	$p = mv$
----------	----------

Moment of force	$= Fx$
-----------------	--------

Work and energy	$\Delta W = F\Delta s$
-----------------	------------------------

$$E_k = \frac{1}{2}mv^2$$

$$\Delta E_{\text{grav}} = mg\Delta h$$

Power	$P = \frac{E}{t}$
-------	-------------------

$$P = \frac{W}{t}$$

Efficiency	efficiency = $\frac{\text{useful energy output}}{\text{total energy input}}$
------------	--

efficiency = $\frac{\text{useful power output}}{\text{total power input}}$
--

##### Materials

Density	$\rho = \frac{m}{V}$
---------	----------------------

Stokes' law	$F = 6\pi\eta rv$
-------------	-------------------

Hooke's law	$\Delta F = k\Delta x$
-------------	------------------------

Elastic strain energy	$\Delta E_{\text{el}} = \frac{1}{2}F\Delta x$
-----------------------	---

Young modulus	$E = \frac{\sigma}{\varepsilon}$ where
---------------	--

$$\text{Stress } \sigma = \frac{F}{A}$$

$$\text{Strain } \varepsilon = \frac{\Delta x}{x}$$

