



UNIVERSITY OF CAMBRIDGE INTERNATIONAL EXAMINATIONS
General Certificate of Education Advanced Level

CANDIDATE
NAME

CENTRE
NUMBER

--	--	--	--	--

CANDIDATE
NUMBER

--	--	--	--

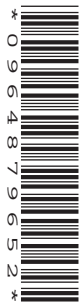

PHYSICS

Paper 5 Planning, Analysis and Evaluation

9702/51

May/June 2013

1 hour 15 minutes

Candidates answer on the Question Paper.

No Additional Materials are required.

READ THESE INSTRUCTIONS FIRST

Write your Centre number, candidate number and name on all the work you hand in.

Write in dark blue or black pen.

You may use a pencil for any diagrams, graphs or rough working.

Do not use staples, paper clips, highlighters, glue or correction fluid.

DO NOT WRITE IN ANY BARCODES.

Answer **all** questions.

Electronic calculators may be used.

You may lose marks if you do not show your working or if you do not use appropriate units.

At the end of the examination, fasten all your work securely together.

The number of marks is given in brackets [] at the end of each question or part question.

This document consists of **8** printed pages.



- 1 A student is investigating the flow of water through a horizontal tube.

The rate Q (volume per unit time) at which water flows through a tube depends on the pressure difference per unit length across the tube.

The student has the use of a metal can with two holes. A narrow horizontal tube goes through the hole in the side of the can. The can is continuously supplied with water from a tap. The level of water in the can is kept constant by the position of a wide vertical tube which passes through the hole in the bottom of the can as shown in Fig. 1.1. Both tubes may be moved along the holes.

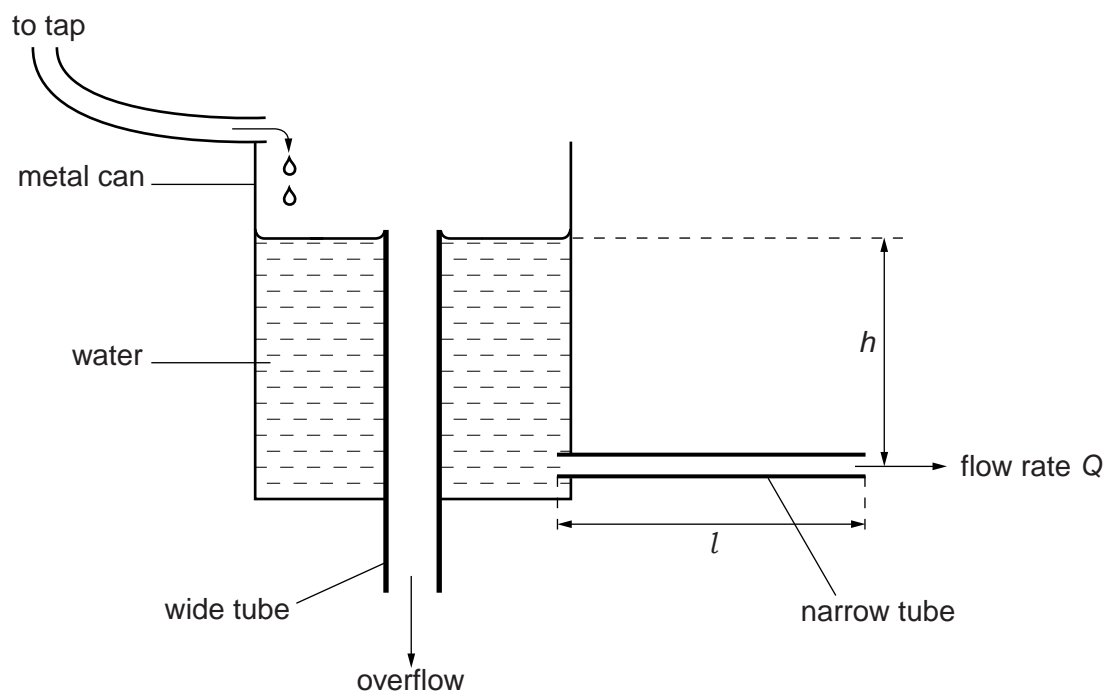

Fig. 1.1

It is suggested that the relationship between the flow rate Q of water through the narrow horizontal tube and the vertical height h is

$$Q = \frac{2\pi\rho gh d^4}{l\eta}$$

where ρ is the density of water, g is the acceleration of free fall, d is the internal diameter of the tube, l is the length of the tube and η is a constant.

Design a laboratory experiment to test the relationship between Q and h and determine a value for η . You should draw a diagram, on page 3, showing the arrangement of your equipment. In your account you should pay particular attention to

- the procedure to be followed,
- the measurements to be taken,
- the control of variables,
- the analysis of the data,
- the safety precautions to be taken.

[15]

Diagram

*For
Examiner's
Use*

.....

.....

.....

.....

.....

.....

.....

.....

.....

.....

.....

.....

.....

.....

.....

.....

.....

.....

.....

.....

.....

.....

.....

- 2 A student is investigating the discharge of capacitors.

A capacitor of capacitance W is charged by connecting it to a power supply of e.m.f. E . The charge is then shared with another capacitor of capacitance C , which is initially uncharged. A voltmeter is used to measure the maximum voltage V across the second capacitor, as shown in Fig. 2.1.

For
Examiner's
Use

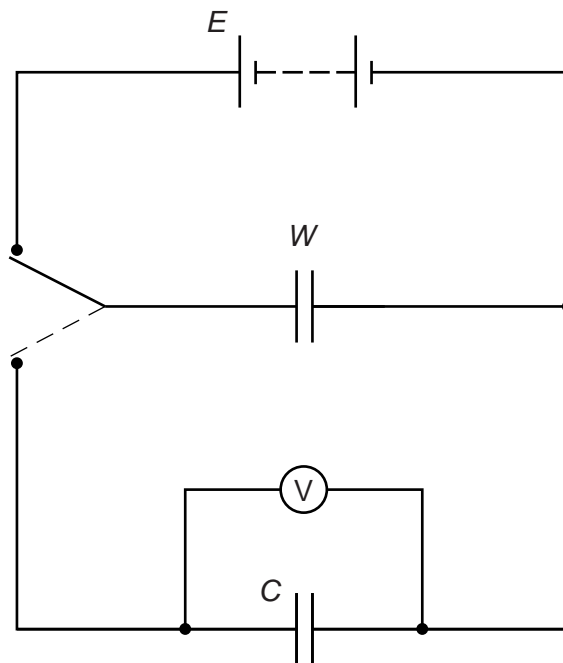

Fig. 2.1

For different values of C , the maximum voltage V is recorded.

Question 2 continues on the next page.

It is suggested that C and V are related by the equation

$$\frac{E}{V} = 1 + \frac{C}{W}$$

For
Examiner's
Use

- (a) A graph is plotted of $1/V$ on the y -axis against C on the x -axis. Determine expressions for the gradient and y -intercept in terms of E and W .

gradient =

y -intercept =

[1]

- (b) Values of C and V are given in Fig. 2.2.

$C/10^{-3}\text{F}$	V/V	
0.69 ± 0.09	5.1	
1.00 ± 0.20	4.5	
1.47 ± 0.29	4.0	
2.20 ± 0.44	3.3	
2.67 ± 0.54	3.0	
3.20 ± 0.64	2.7	

Fig. 2.2

Calculate and record values of $1/V$ in Fig. 2.2. [2]

- (c) (i) Plot a graph of $(1/V)/V^{-1}$ against $C/10^{-3}\text{F}$. Include error bars for C . [2]
- (ii) Draw the straight line of best fit and a worst acceptable straight line on your graph. Both lines should be clearly labelled. [2]
- (iii) Determine the gradient of the line of best fit. Include the uncertainty in your answer.

gradient = [2]

For
Examiner's
Use

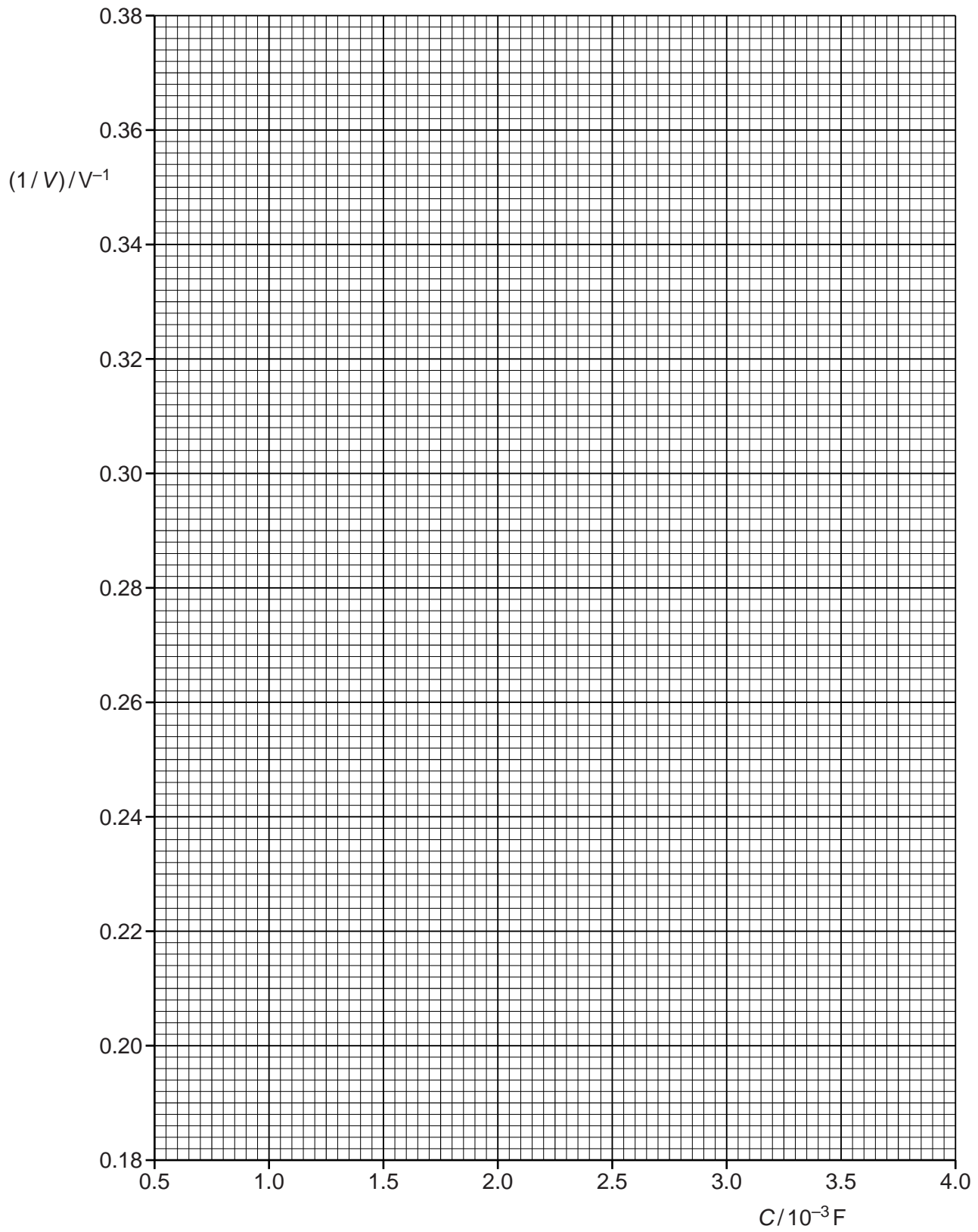

- (iv) Determine the y -intercept of the line of best fit. Include the uncertainty in your answer.

For
Examiner's
Use

y -intercept = [2]

- (d) (i) Using your answer to (c)(iv), determine a value for E . Include an appropriate unit in your answer. Include the absolute uncertainty in E .

E = [2]

- (ii) Using your answers to (c)(iii) and (d)(i), determine a value for W . Include an appropriate unit in your answer.

W = [1]

- (iii) Determine the percentage uncertainty in your value of W .

percentage uncertainty = % [1]

Permission to reproduce items where third-party owned material protected by copyright is included has been sought and cleared where possible. Every reasonable effort has been made by the publisher (UCLES) to trace copyright holders, but if any items requiring clearance have unwittingly been included, the publisher will be pleased to make amends at the earliest possible opportunity.

University of Cambridge International Examinations is part of the Cambridge Assessment Group. Cambridge Assessment is the brand name of University of Cambridge Local Examinations Syndicate (UCLES), which is itself a department of the University of Cambridge.