



UNIVERSITY OF CAMBRIDGE INTERNATIONAL EXAMINATIONS  
General Certificate of Education Advanced Level

CANDIDATE  
NAME

CENTRE  
NUMBER

--	--	--	--	--

CANDIDATE  
NUMBER

--	--	--	--



**PHYSICS**

Paper 4 A2 Structured Questions

**9702/42**

**May/June 2013**

**2 hours**

Candidates answer on the Question Paper.

No Additional Materials are required.

**READ THESE INSTRUCTIONS FIRST**

Write your Centre number, candidate number and name on all the work you hand in.

Write in dark blue or black pen.

You may use a pencil for any diagrams, graphs or rough working.

Do not use staples, paper clips, highlighters, glue or correction fluid.

**DO NOT WRITE IN ANY BARCODES.**

Answer **all** questions.

Electronic calculators may be used.

You may lose marks if you do not show your working or if you do not use appropriate units.

At the end of the examination, fasten all your work securely together.

The number of marks is given in brackets [ ] at the end of each question or part question.

**For Examiner's Use**

1	
2	
3	
4	
5	
6	
7	
8	
9	
10	
11	
12	
<b>Total</b>	

This document consists of **22** printed pages and **2** blank pages.



## 2

**Data**

speed of light in free space,	$c = 3.00 \times 10^8 \text{ m s}^{-1}$
permeability of free space,	$\mu_0 = 4\pi \times 10^{-7} \text{ H m}^{-1}$
permittivity of free space,	$\epsilon_0 = 8.85 \times 10^{-12} \text{ F m}^{-1}$
	$(\frac{1}{4\pi\epsilon_0} = 8.99 \times 10^9 \text{ m F}^{-1})$
elementary charge,	$e = 1.60 \times 10^{-19} \text{ C}$
the Planck constant,	$h = 6.63 \times 10^{-34} \text{ J s}$
unified atomic mass constant,	$u = 1.66 \times 10^{-27} \text{ kg}$
rest mass of electron,	$m_e = 9.11 \times 10^{-31} \text{ kg}$
rest mass of proton,	$m_p = 1.67 \times 10^{-27} \text{ kg}$
molar gas constant,	$R = 8.31 \text{ J K}^{-1} \text{ mol}^{-1}$
the Avogadro constant,	$N_A = 6.02 \times 10^{23} \text{ mol}^{-1}$
the Boltzmann constant,	$k = 1.38 \times 10^{-23} \text{ J K}^{-1}$
gravitational constant,	$G = 6.67 \times 10^{-11} \text{ N m}^2 \text{ kg}^{-2}$
acceleration of free fall,	$g = 9.81 \text{ m s}^{-2}$

**Formulae**

uniformly accelerated motion,	$s = ut + \frac{1}{2}at^2$ $v^2 = u^2 + 2as$
work done on/by a gas,	$W = p\Delta V$
gravitational potential,	$\phi = -\frac{Gm}{r}$
hydrostatic pressure,	$p = \rho gh$
pressure of an ideal gas,	$p = \frac{1}{3} \frac{Nm}{V} \langle c^2 \rangle$
simple harmonic motion,	$a = -\omega^2 x$
velocity of particle in s.h.m.,	$v = v_0 \cos \omega t$ $v = \pm \omega \sqrt{(x_0^2 - x^2)}$
electric potential,	$V = \frac{Q}{4\pi\epsilon_0 r}$
capacitors in series,	$1/C = 1/C_1 + 1/C_2 + \dots$
capacitors in parallel,	$C = C_1 + C_2 + \dots$
energy of charged capacitor,	$W = \frac{1}{2} QV$
resistors in series,	$R = R_1 + R_2 + \dots$
resistors in parallel,	$1/R = 1/R_1 + 1/R_2 + \dots$
alternating current/voltage,	$x = x_0 \sin \omega t$
radioactive decay,	$x = x_0 \exp(-\lambda t)$
decay constant,	$\lambda = \frac{0.693}{t_{\frac{1}{2}}}$

## Section A

Answer **all** the questions in the spaces provided.

For  
Examiner's  
Use

- 1 (a) Explain what is meant by a *geostationary orbit*.

.....  
 .....  
 .....  
 ..... [3]

- (b) A satellite of mass  $m$  is in a circular orbit about a planet.  
 The mass  $M$  of the planet may be considered to be concentrated at its centre.  
 Show that the radius  $R$  of the orbit of the satellite is given by the expression

$$R^3 = \left( \frac{GMT^2}{4\pi^2} \right)$$

where  $T$  is the period of the orbit of the satellite and  $G$  is the gravitational constant.  
 Explain your working.

[4]

- (c) The Earth has mass  $6.0 \times 10^{24}$  kg. Use the expression given in (b) to determine the radius of the geostationary orbit about the Earth.

radius = ..... m [3]

5

- 2 (a) The volume of an ideal gas in a cylinder is  $1.80 \times 10^{-3} \text{ m}^3$  at a pressure of  $2.60 \times 10^5 \text{ Pa}$  and a temperature of  $297 \text{ K}$ , as illustrated in Fig. 2.1.

For  
Examiner's  
Use

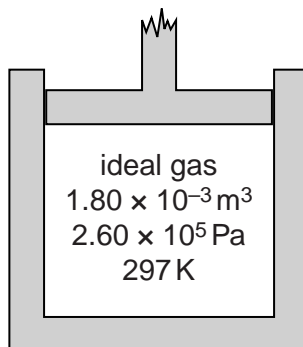

**Fig. 2.1**

The thermal energy required to raise the temperature by  $1.00 \text{ K}$  of  $1.00 \text{ mol}$  of the gas at constant volume is  $12.5 \text{ J}$ .

The gas is heated at constant volume such that the internal energy of the gas increases by  $95.0 \text{ J}$ .

- (i) Calculate

1. the amount of gas, in mol, in the cylinder,

amount = ..... mol [2]

2. the rise in temperature of the gas.

temperature rise = ..... K [2]

(ii) Use your answer in (i) part 2 to show that the final pressure of the gas in the cylinder is  $2.95 \times 10^5$  Pa.

For  
Examiner's  
Use

[1]

(b) The gas is now allowed to expand. No thermal energy enters or leaves the gas. The gas does 120 J of work when expanding against the external pressure.

State and explain whether the final temperature of the gas is above or below 297 K.

.....  
.....  
.....  
..... [3]

3 A mass of 78 g is suspended from a fixed point by means of a spring, as illustrated in Fig. 3.1.

For  
Examiner's  
Use

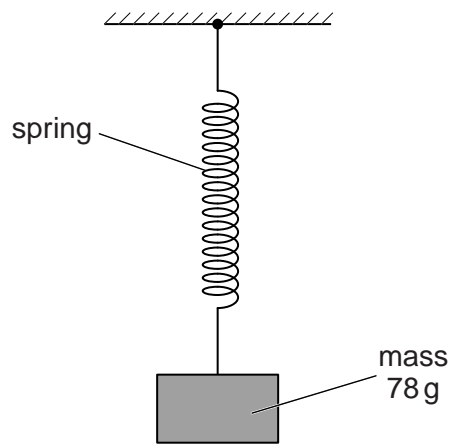

Fig. 3.1

The stationary mass is pulled vertically downwards through a distance of 2.1 cm and then released.

The mass is observed to perform simple harmonic motion with a period of 0.69 s.

(a) The mass is released at time  $t = 0$ .

For the oscillations of the mass,

(i) calculate the angular frequency  $\omega$ ,

$\omega = \dots\dots\dots \text{ rad s}^{-1}$  [2]

(ii) determine numerical equations for the variation with time  $t$  of

1. the displacement  $x$  in cm,

.....  
 ..... [2]

2. the speed  $v$  in  $\text{ms}^{-1}$ .

.....  
 ..... [2]

8

(b) Calculate the total energy of oscillation of the mass.

For  
Examiner's  
Use

energy = ..... J [2]



- 4 (a) An insulated metal sphere of radius  $R$  is situated in a vacuum. The charge  $q$  on the sphere may be considered to be a point charge at the centre of the sphere.

For  
Examiner's  
Use

- (i) State a formula, in terms of  $R$  and  $q$ , for the potential  $V$  on the surface of the sphere.

..... [1]

- (ii) Define capacitance and hence show that the capacitance  $C$  of the sphere is given by the expression

$$C = 4\pi\epsilon_0 R.$$

[1]

- (b) An isolated metal sphere has radius 45 cm.

- (i) Use the expression in (a)(ii) to calculate the capacitance, in picofarad, of the sphere.

capacitance = ..... pF [2]

- (ii) The sphere is charged to a potential of  $9.0 \times 10^5$  V.  
A spark occurs, partially discharging the sphere so that its potential is reduced to  $3.6 \times 10^5$  V.

Determine the energy of the spark.

energy = ..... J [3]

5 (a) Define the *tesla*.

.....  
 .....  
 ..... [2]

For  
 Examiner's  
 Use

(b) Two long straight vertical wires X and Y are separated by a distance of 4.5 cm, as illustrated in Fig. 5.1.

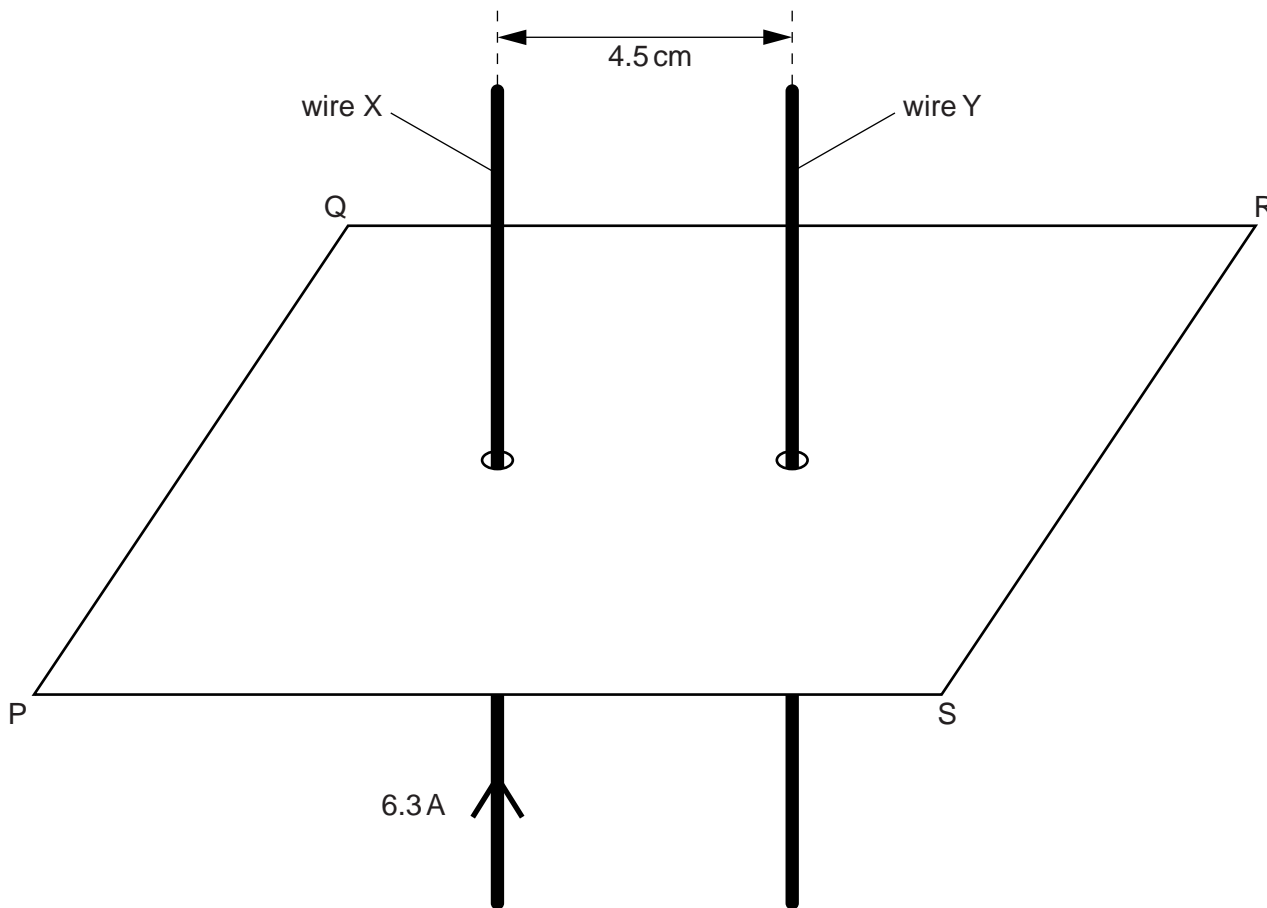

Fig. 5.1

The wires pass through a horizontal card PQRS.  
 The current in wire X is 6.3 A in the upward direction. Initially, there is no current in wire Y.

(i) On Fig. 5.1, sketch, in the plane PQRS, the magnetic flux pattern due to the current in wire X. Show at least four flux lines. [3]

- (ii) The magnetic flux density  $B$  at a distance  $x$  from a long straight current-carrying wire is given by the expression

$$B = \frac{\mu_0 I}{2\pi x}$$

where  $I$  is the current in the wire and  $\mu_0$  is the permeability of free space.

Calculate the magnetic flux density at wire Y due to the current in wire X.

For  
Examiner's  
Use

flux density = ..... T [2]

- (iii) A current of 9.3A is now switched on in wire Y. Use your answer in (ii) to calculate the force per unit length on wire Y.

force per unit length = .....  $\text{Nm}^{-1}$  [2]

- (c) The currents in the two wires in (b)(iii) are not equal.  
Explain whether the force per unit length on the two wires will be the same, or different.

.....

.....

..... [2]

6 (a) State Faraday's law of electromagnetic induction.

.....  
 .....  
 ..... [2]

For  
 Examiner's  
 Use

(b) The output of an ideal transformer is connected to a bridge rectifier, as shown in Fig. 6.1.

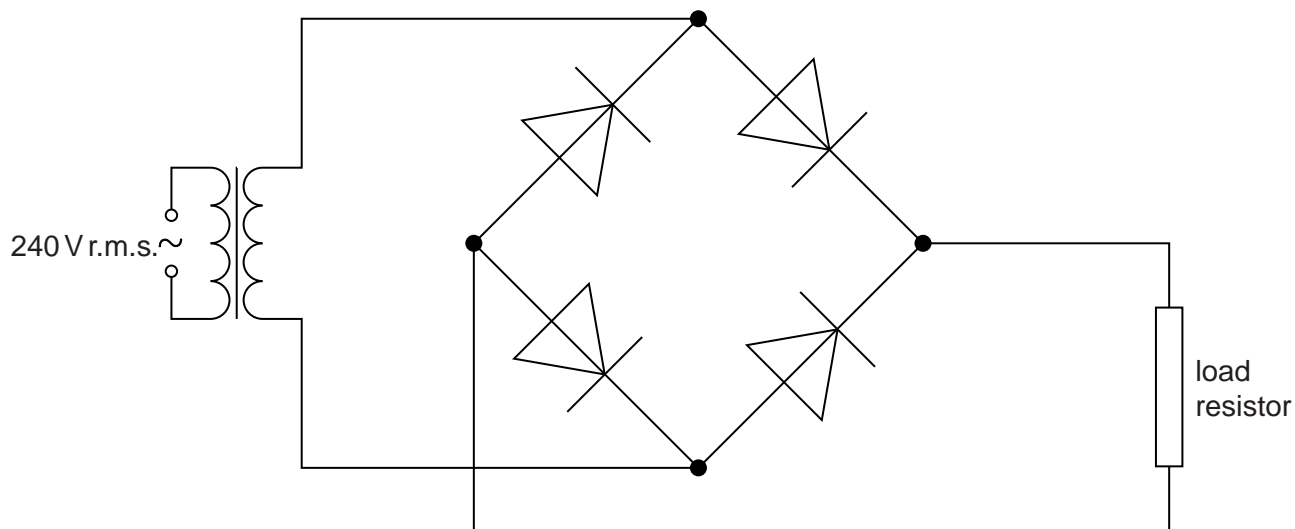

Fig. 6.1

The input to the transformer is 240 V r.m.s. and the **maximum** potential difference across the load resistor is 9.0 V.

(i) On Fig. 6.1, mark with the letter P the positive output from the rectifier. [1]

(ii) Calculate the ratio

$$\frac{\text{number of turns on primary coil}}{\text{number of turns on secondary coil}}$$

ratio = ..... [3]

- (c) The variation with time  $t$  of the potential difference  $V$  across the load resistor in (b) is shown in Fig. 6.2.

For  
Examiner's  
Use

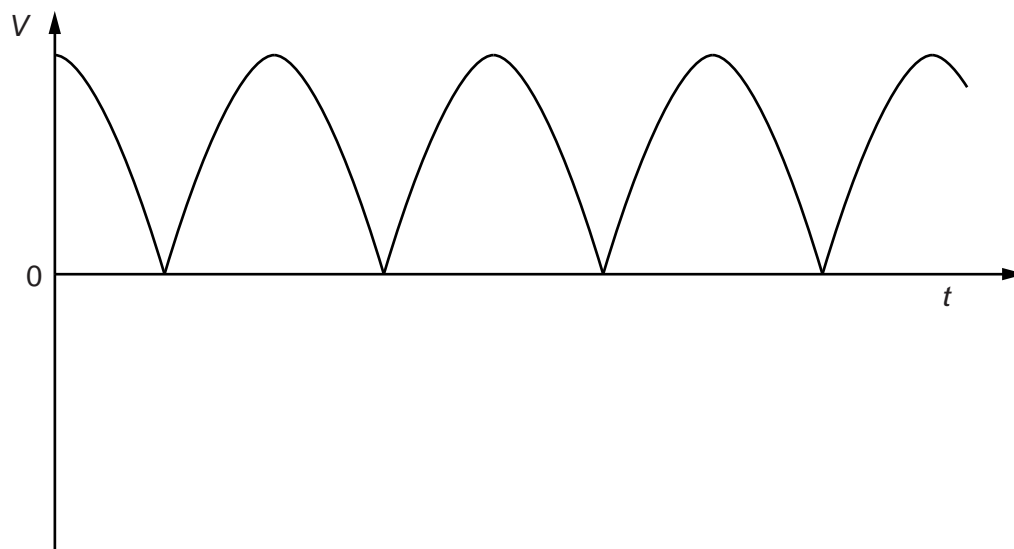

**Fig. 6.2**

A capacitor is now connected in parallel with the load resistor to produce some smoothing.

- (i) Explain what is meant by *smoothing*.

.....  
 ..... [1]

- (ii) On Fig. 6.2, draw the variation with time  $t$  of the smoothed output potential difference. [2]

- 7 (a) The emission spectrum of atomic hydrogen consists of a number of discrete wavelengths. Explain how this observation leads to an understanding that there are discrete electron energy levels in atoms.

For  
Examiner's  
Use

.....

.....

.....

..... [2]

- (b) Some electron energy levels in atomic hydrogen are illustrated in Fig. 7.1.

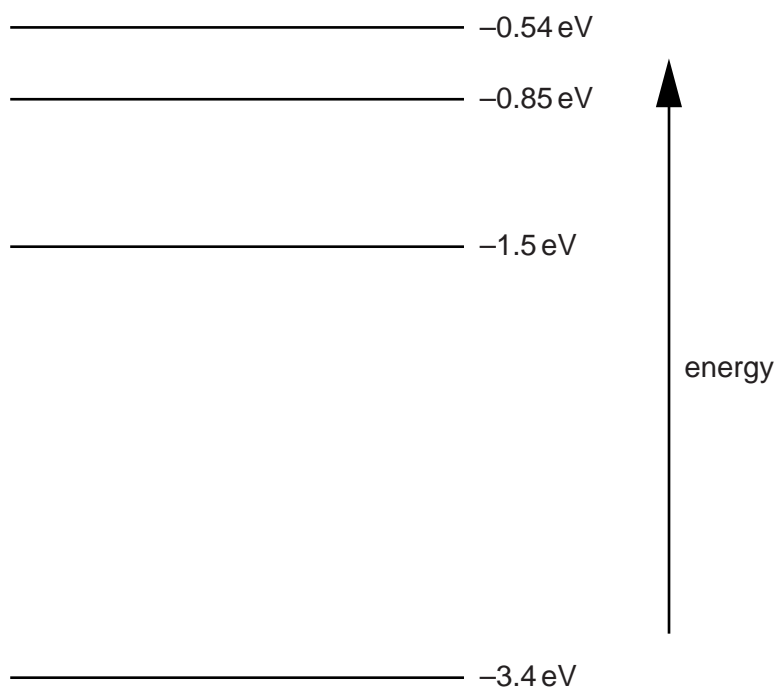

Fig. 7.1

The longest wavelength produced as a result of electron transitions between two of the energy levels shown in Fig. 7.1 is  $4.0 \times 10^{-6}$  m.

For  
Examiner's  
Use

(i) On Fig. 7.1,

1. draw, and mark with the letter L, the transition giving rise to the wavelength of  $4.0 \times 10^{-6}$  m, [1]

2. draw, and mark with the letter S, the transition giving rise to the shortest wavelength. [1]

(ii) Calculate the wavelength for the transition you have shown in (i) part 2.

wavelength = ..... m [3]

(c) Photon energies in the visible spectrum vary between approximately 3.66 eV and 1.83 eV.

Determine the energies, in eV, of photons in the visible spectrum that are produced by transitions between the energy levels shown in Fig. 7.1.

photon energies ..... eV [2]

- 8 (a) Explain why the mass of an  $\alpha$ -particle is less than the total mass of two individual protons and two individual neutrons.

For  
Examiner's  
Use

.....  
 .....  
 ..... [2]

- (b) An equation for one possible nuclear reaction is

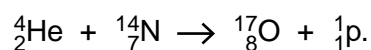

Data for the masses of the nuclei are given in Fig. 8.1.

		mass/u
proton	${}^1_1\text{p}$	1.00728
helium-4	${}^4_2\text{He}$	4.00260
nitrogen-14	${}^{14}_7\text{N}$	14.00307
oxygen-17	${}^{17}_8\text{O}$	16.99913

**Fig. 8.1**

- (i) Calculate the mass change, in u, associated with this reaction.

mass change = ..... u [2]

- (ii) Calculate the energy, in J, associated with the mass change in (i).

energy = ..... J [2]



(iii) Suggest and explain why, for this reaction to occur, the helium-4 nucleus must have a minimum speed.

For  
Examiner's  
Use

.....

.....

..... [2]

**Section B**

Answer **all** the questions in the spaces provided.

For  
Examiner's  
Use

- 9 The volume of fuel in the fuel tank of a car is monitored using a sensing device. The device gives a voltage output that is measured using a voltmeter. The variation of voltmeter reading with the volume of fuel in the tank is shown in Fig. 9.1.

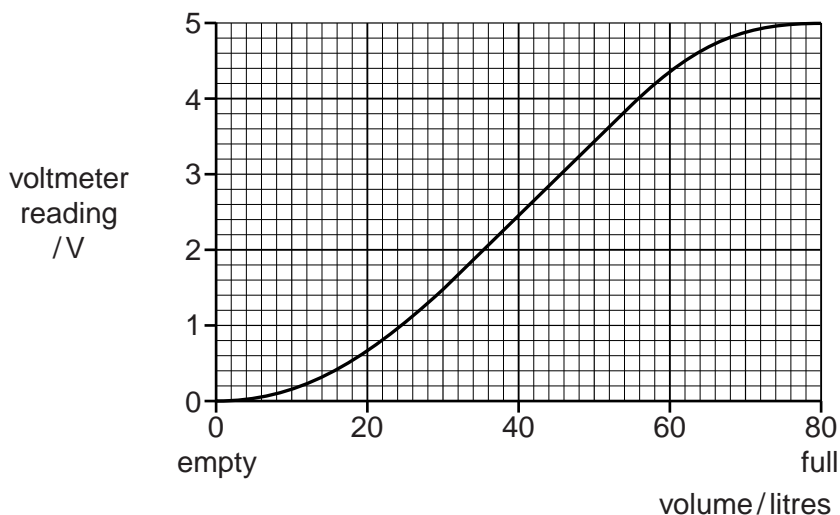

**Fig. 9.1**

- (a) Use Fig. 9.1 to determine the range of volume over which the volume has a linear relationship to the voltmeter reading.

from ..... litres to ..... litres [1]

- (b) Suggest why, comparing values from Fig. 9.1,

- (i) when the tank is nearly full, the voltmeter readings give the impression that fuel consumption is low,

.....  
 .....  
 ..... [2]

- (ii) when the voltmeter first indicates that the tank is nearly empty, there is more fuel remaining than is expected.

.....  
 .....  
 ..... [2]

10 (a) By reference to ultrasound waves, state what is meant by *acoustic impedance*.

For  
Examiner's  
Use

.....  
.....  
..... [2]

(b) An ultrasound wave is incident on the boundary between two media. The acoustic impedances of the two media are  $Z_1$  and  $Z_2$ , as illustrated in Fig. 10.1.

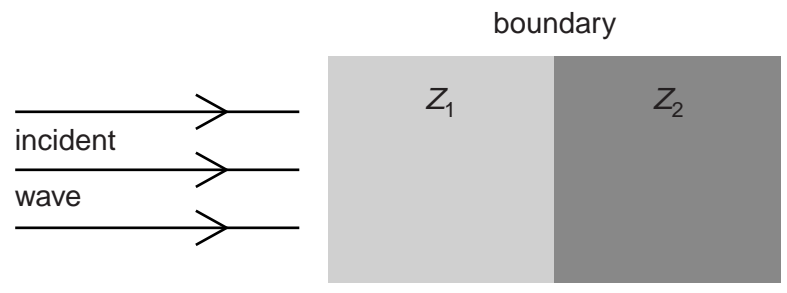

Fig. 10.1

Explain the importance of the difference between  $Z_1$  and  $Z_2$  for the transmission of ultrasound across the boundary.

.....  
.....  
.....  
..... [3]

(c) Ultrasound frequencies as high as 10 MHz are used in medical diagnosis. State and explain one advantage of the use of high-frequency ultrasound compared with lower-frequency ultrasound.

.....  
.....  
..... [2]

**BLANK PAGE**

- 11 (a) Explain how the hardness of an X-ray beam is controlled by the accelerating voltage in the X-ray tube.

For  
Examiner's  
Use

.....  
 .....  
 ..... [2]

- (b) The attenuation of a parallel beam of X-ray radiation is given by the expression

$$\frac{I}{I_0} = e^{-\mu x}$$

where  $\mu$  is the linear attenuation (absorption) coefficient and  $x$  is the thickness of the material through which the beam passes.

- (i) State

1. what is meant by *attenuation*,

.....  
 ..... [1]

2. why the expression applies only to a parallel beam.

.....  
 .....  
 ..... [2]

- (ii) The linear attenuation coefficients for X-rays in bone and in soft tissue are  $2.9 \text{ cm}^{-1}$  and  $0.95 \text{ cm}^{-1}$  respectively.

Calculate, for a parallel X-ray beam, the ratio

$$\frac{\text{fraction } \frac{I}{I_0} \text{ of intensity transmitted through bone of thickness } 2.5 \text{ cm}}{\text{fraction } \frac{I}{I_0} \text{ of intensity transmitted through soft tissue of thickness } 6.0 \text{ cm}}$$

ratio = ..... [2]

12 The digital transmission of speech may be represented by the block diagram of Fig. 12.1.

For  
Examiner's  
Use

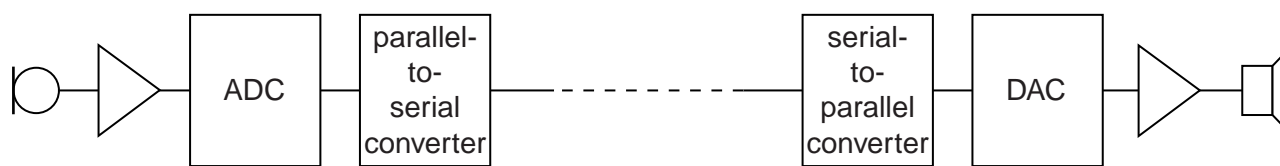

Fig. 12.1

(a) State the purpose of the parallel-to-serial converter.

.....

.....

..... [2]

(b) Part of the signal from the microphone is shown in Fig. 12.2.

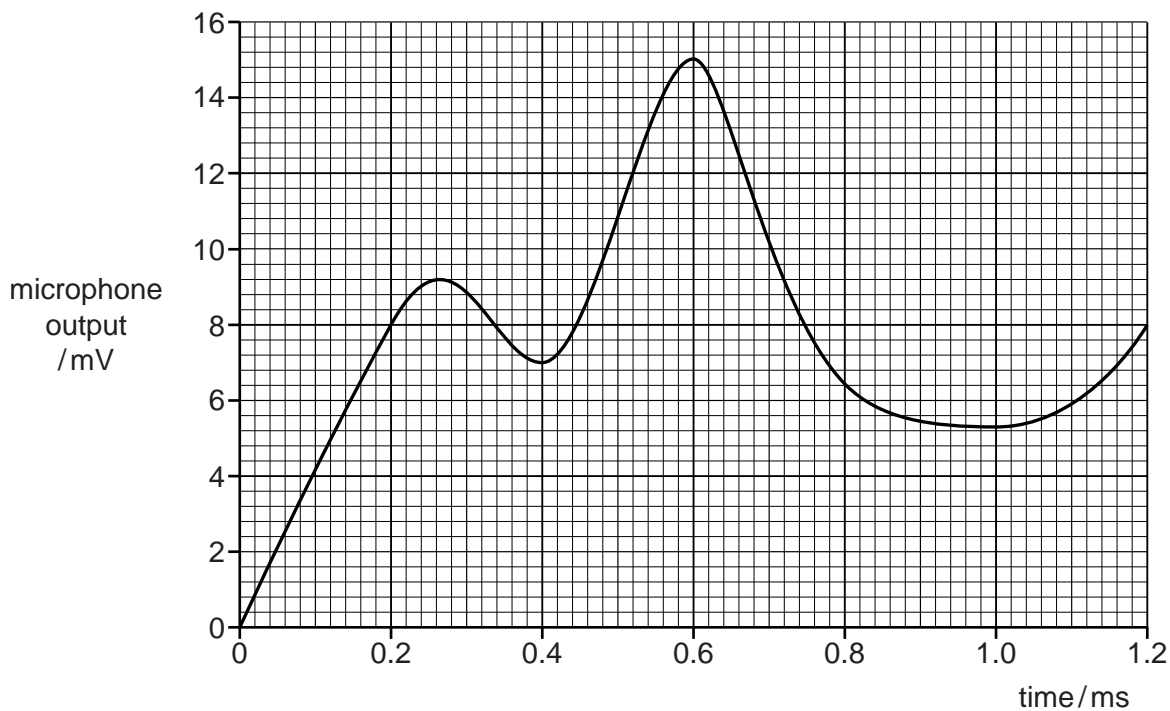

Fig. 12.2

The ADC (analogue-to-digital converter) samples the analogue signal at a frequency of 5.0kHz.

Each sample from the ADC is a four-bit digital number where the smallest bit represents 1.0mV.

The first sample is taken at time zero.

Use Fig. 12.2 to determine the four-bit digital number produced by the ADC at times

(i) 0.4 ms,

..... [1]

(ii) 0.8 ms.

..... [1]

(c) The digital signal is transmitted and then converted to an analogue form by the DAC (digital-to-analogue converter).

Using data from Fig. 12.2, draw, on the axes of Fig. 12.3, the output level of the transmitted analogue signal for time zero to time 1.2ms.

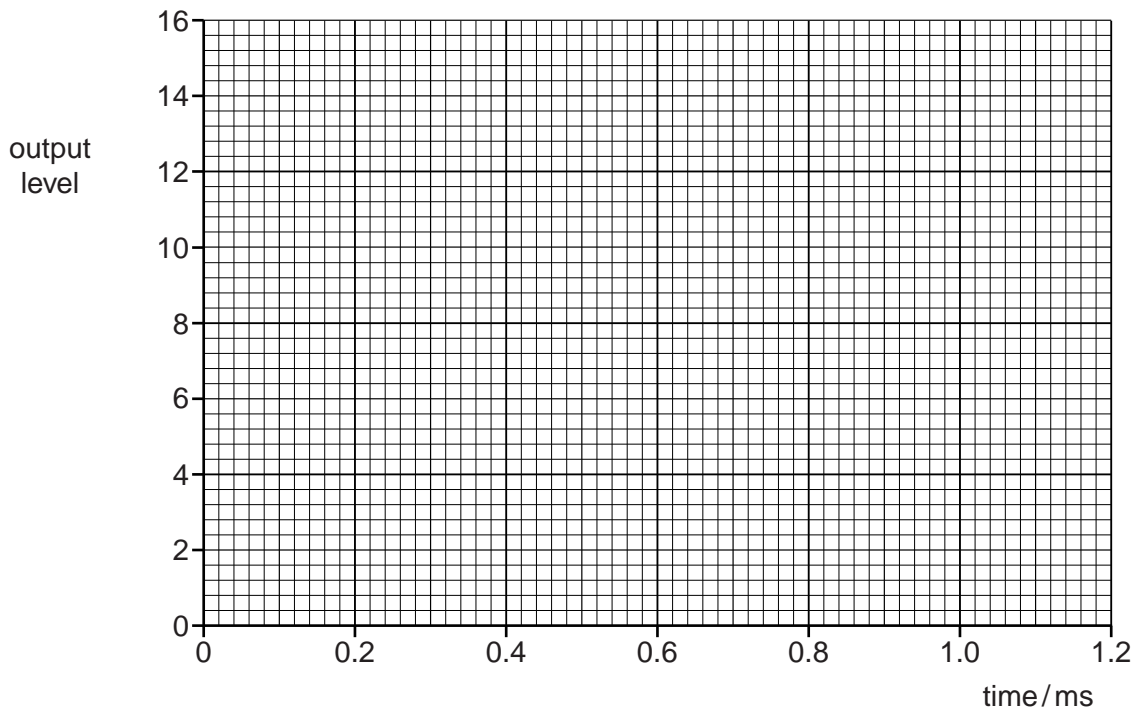

[4]

Fig. 12.3

(d) State and explain the effect on the transmitted analogue waveform of increasing, for the ADC and the DAC, both the sampling frequency and the number of bits in each sample.

.....  
.....  
.....  
..... [3]

**BLANK PAGE**

---

Permission to reproduce items where third-party owned material protected by copyright is included has been sought and cleared where possible. Every reasonable effort has been made by the publisher (UCLES) to trace copyright holders, but if any items requiring clearance have unwittingly been included, the publisher will be pleased to make amends at the earliest possible opportunity.

University of Cambridge International Examinations is part of the Cambridge Assessment Group. Cambridge Assessment is the brand name of University of Cambridge Local Examinations Syndicate (UCLES), which is itself a department of the University of Cambridge.