

2

Data

speed of light in free space,	$c = 3.00 \times 10^8 \text{ m s}^{-1}$
permeability of free space,	$\mu_0 = 4\pi \times 10^{-7} \text{ H m}^{-1}$
permittivity of free space,	$\epsilon_0 = 8.85 \times 10^{-12} \text{ F m}^{-1}$
	$(\frac{1}{4\pi\epsilon_0} = 8.99 \times 10^9 \text{ mF}^{-1})$
elementary charge,	$e = 1.60 \times 10^{-19} \text{ C}$
the Planck constant,	$h = 6.63 \times 10^{-34} \text{ J s}$
unified atomic mass constant,	$u = 1.66 \times 10^{-27} \text{ kg}$
rest mass of electron,	$m_e = 9.11 \times 10^{-31} \text{ kg}$
rest mass of proton,	$m_p = 1.67 \times 10^{-27} \text{ kg}$
molar gas constant,	$R = 8.31 \text{ J K}^{-1} \text{ mol}^{-1}$
the Avogadro constant,	$N_A = 6.02 \times 10^{23} \text{ mol}^{-1}$
the Boltzmann constant,	$k = 1.38 \times 10^{-23} \text{ J K}^{-1}$
gravitational constant,	$G = 6.67 \times 10^{-11} \text{ N m}^2 \text{ kg}^{-2}$
acceleration of free fall,	$g = 9.81 \text{ m s}^{-2}$

3

Formulae

uniformly accelerated motion,

$$s = ut + \frac{1}{2}at^2$$

$$v^2 = u^2 + 2as$$

work done on/by a gas,

$$W = p\Delta V$$

gravitational potential,

$$\phi = -\frac{Gm}{r}$$

hydrostatic pressure,

$$p = \rho gh$$

pressure of an ideal gas,

$$p = \frac{1}{3} \frac{Nm}{V} \langle c^2 \rangle$$

simple harmonic motion,

$$a = -\omega^2 x$$

velocity of particle in s.h.m.,

$$v = v_0 \cos \omega t$$

$$v = \pm \omega \sqrt{(x_0^2 - x^2)}$$

electric potential,

$$V = \frac{Q}{4\pi\epsilon_0 r}$$

capacitors in series,

$$1/C = 1/C_1 + 1/C_2 + \dots$$

capacitors in parallel,

$$C = C_1 + C_2 + \dots$$

energy of charged capacitor,

$$W = \frac{1}{2} QV$$

resistors in series,

$$R = R_1 + R_2 + \dots$$

resistors in parallel,

$$1/R = 1/R_1 + 1/R_2 + \dots$$

alternating current/voltage,

$$x = x_0 \sin \omega t$$

radioactive decay,

$$x = x_0 \exp(-\lambda t)$$

decay constant,

$$\lambda = \frac{0.693}{t_{\frac{1}{2}}}$$

Answer **all** the questions in the spaces provided.

- 1 (a) Mass, length and time are SI base quantities.
State two other base quantities.

1.

2.

[2]

- (b) A mass m is placed on the end of a spring that is hanging vertically, as shown in Fig. 1.1.

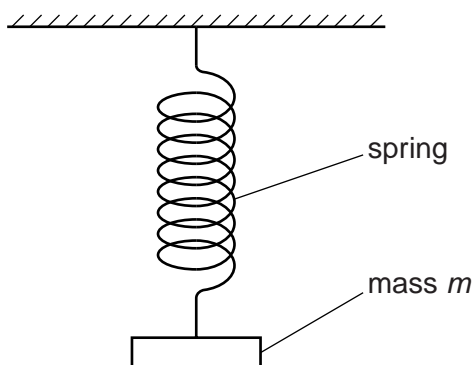

Fig. 1.1

The mass is made to oscillate vertically. The time period of the oscillations of the mass is T .

The period T is given by

$$T = C \sqrt{\frac{m}{k}}$$

where C is a constant and k is the spring constant.

Show that C has no units.

[3]

2 (a) Define *pressure*.

..... [1]

(b) A cylinder is placed on a horizontal surface, as shown in Fig. 2.1.

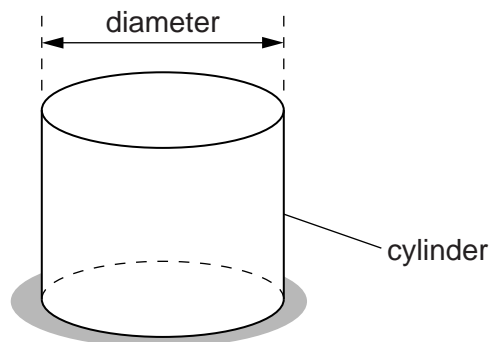

Fig. 2.1

The following measurements were made on the cylinder:

mass = 5.09 ± 0.01 kg

diameter = 9.4 ± 0.1 cm.

(i) Calculate the pressure produced by the cylinder on the surface.

pressure = Pa [3]

(ii) Calculate the actual uncertainty in the pressure.

actual uncertainty = Pa [3]

(iii) State the pressure, with its actual uncertainty.

pressure = \pm Pa [1]

- 3 The resistance R of a uniform metal wire is measured for different lengths l of the wire. The variation with l of R is shown in Fig. 3.1.

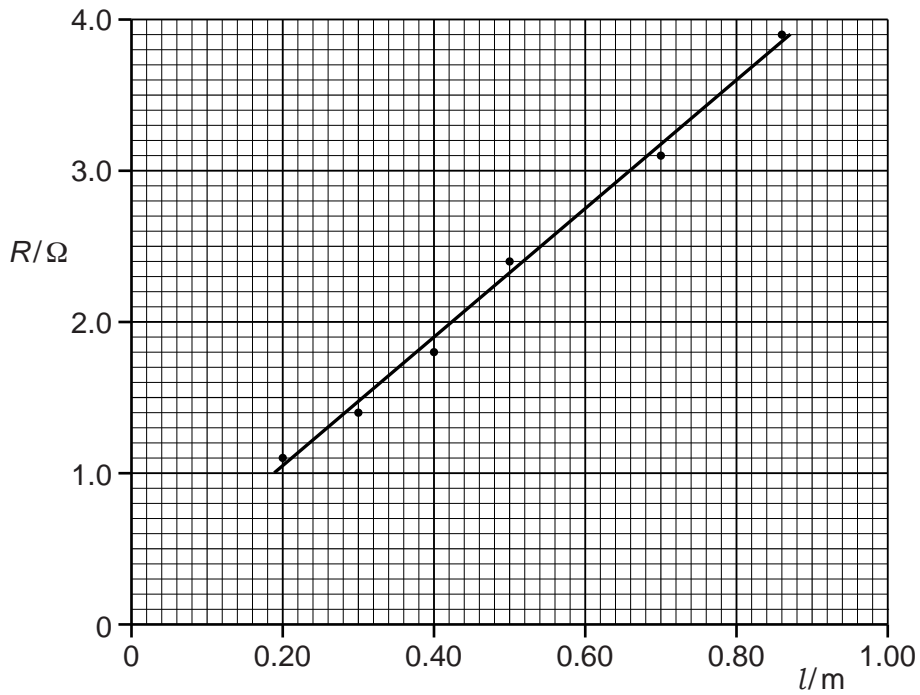

Fig. 3.1

- (a) The points shown in Fig. 3.1 do not lie on the best-fit line. Suggest a reason for this.

.....
 [1]

- (b) Determine the gradient of the line shown in Fig. 3.1.

gradient = [2]

- (c) The cross-sectional area of the wire is 0.12 mm^2 .

Use your answer in (b) to determine the resistivity of the metal of the wire.

resistivity = $\Omega \text{ m}$ [3]

7

- (d) The resistance R of different wires is measured. The wires are of the same metal and same length but have different cross-sectional areas A .

On Fig. 3.2, sketch a graph to show the variation with A of R .



Fig. 3.2

[2]

4 A trolley moves down a slope, as shown in Fig. 4.1.

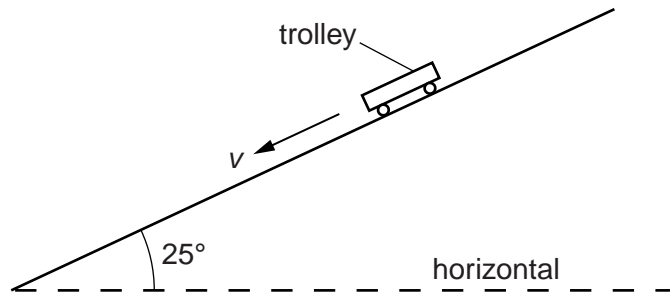

Fig. 4.1

The slope makes an angle of 25° with the horizontal. A constant resistive force F_R acts up the slope on the trolley.

At time $t = 0$, the trolley has velocity $v = 0.50 \text{ m s}^{-1}$ down the slope.

At time $t = 4.0 \text{ s}$, $v = 12 \text{ m s}^{-1}$ down the slope.

(a) (i) Show that the acceleration of the trolley down the slope is approximately 3 m s^{-2} .

[2]

(ii) Calculate the distance x moved by the trolley down the slope from time $t = 0$ to $t = 4.0 \text{ s}$.

$x = \dots\dots\dots \text{ m}$ [2]

(iii) On Fig. 4.2, sketch the variation with time t of distance x moved by the trolley.

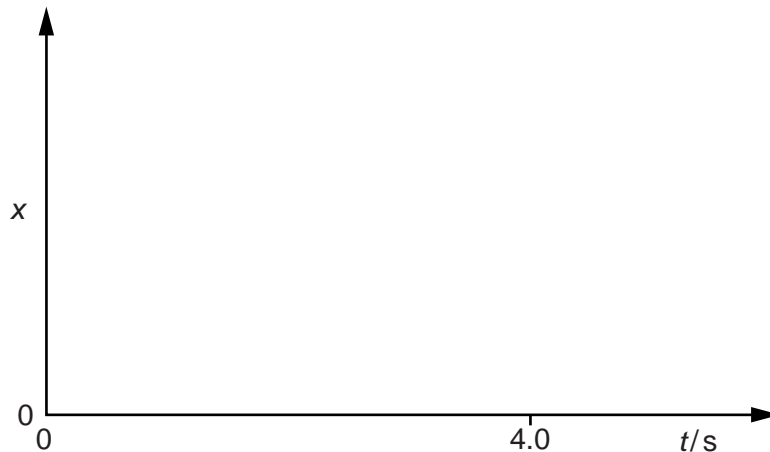

Fig. 4.2

[2]

9

(b) The mass of the trolley is 2.0 kg.

(i) Show that the component of the weight of the trolley down the slope is 8.3 N.

[1]

(ii) Calculate the resistive force F_R .

$F_R = \dots\dots\dots$ N [2]

- 5 A motor is used to move bricks vertically upwards, as shown in Fig. 5.1.

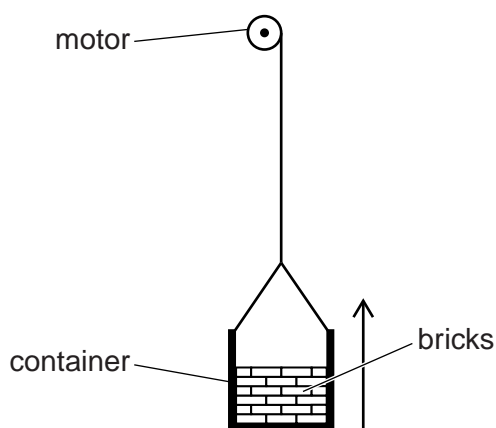

Fig. 5.1

The bricks start from rest and accelerate for 2.0 s. The bricks then travel at a constant speed of 0.64 m s^{-1} for 25 s. Finally the bricks are brought to rest in a further 3.0 s.

The total mass of the bricks is 25 kg.

- (a)** Determine the change in kinetic energy of the bricks

- (i)** in the first 2.0 s,

change in kinetic energy = J [2]

- (ii)** in the next 25 s,

change in kinetic energy = J [1]

- (iii)** in the final 3.0 s.

change in kinetic energy = J [1]

(b) The bricks are in a container. The weight of the container and bricks is 350 N.

Calculate, for the lifting of the bricks and container when travelling at constant speed,

(i) the gain in potential energy,

energy gain = J [3]

(ii) the power required.

power = W [2]

6 Distinguish between *melting* and *evaporation*.

melting:

.....

.....

evaporation:

.....

.....

[4]

7 (a) A cell with internal resistance supplies a current. Explain why the terminal potential difference (p.d.) is less than the electromotive force (e.m.f.) of the cell.

.....

.....

..... [1]

(b) A battery of e.m.f. 12V and internal resistance $0.50\ \Omega$ is connected to a variable resistor X and a resistor Y of constant resistance, as shown in Fig. 7.1.

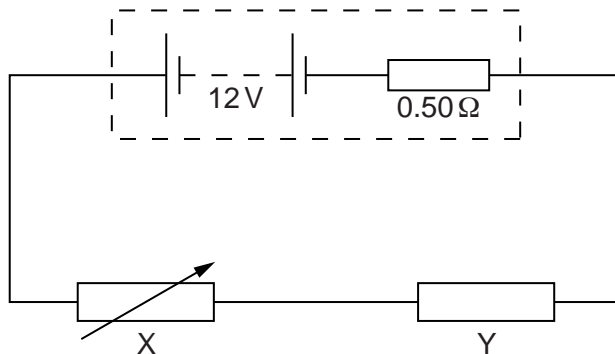

Fig. 7.1

The resistance R of X is increased from $2.0\ \Omega$ to $16\ \Omega$. The variation with R of the current I in the circuit is shown in Fig. 7.2.

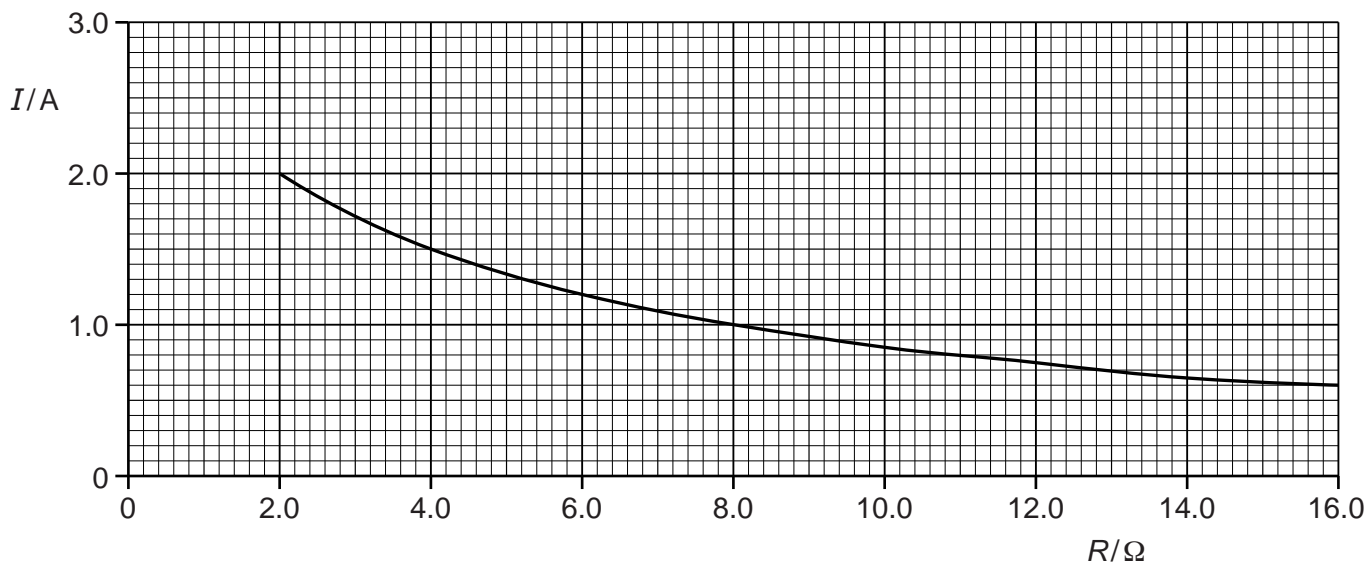

Fig. 7.2

Calculate, for $I = 1.2\text{ A}$,

(i) the p.d. across X,

p.d. = V [2]

(ii) the resistance of Y,

resistance = Ω [3]

(iii) the power dissipated in the battery.

power = W [2]

(c) Use Fig. 7.2 to explain the variation in the terminal p.d. of the battery as the resistance R of X is increased.

.....
 [1]

8 (a) Explain how stationary waves are formed.

.....

.....

..... [2]

(b) The arrangement of apparatus used to determine the wavelength of a sound wave is shown in Fig. 8.1.

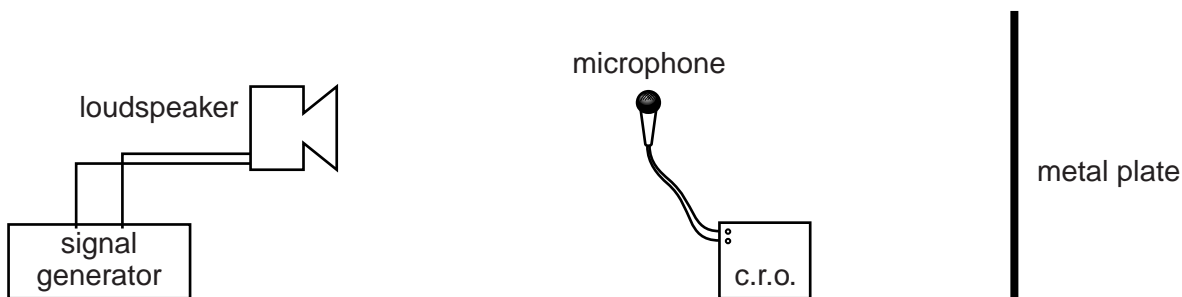

Fig. 8.1

The loudspeaker emits sound of one frequency. The microphone is connected to a cathode-ray oscilloscope (c.r.o.). The waveform obtained on the c.r.o. for one position of the microphone is shown in Fig. 8.2.

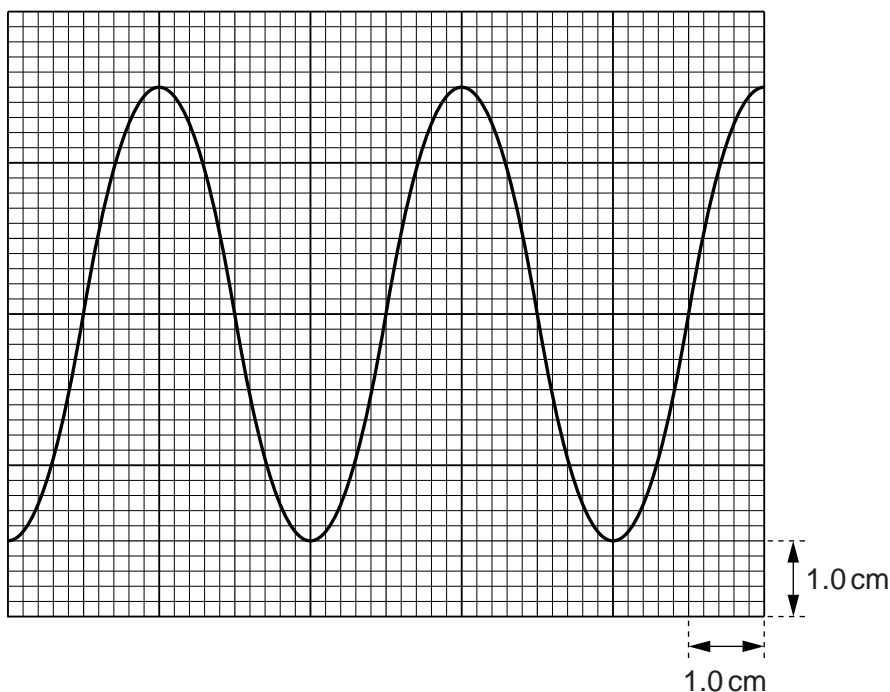

Fig. 8.2

The time-base setting of the c.r.o. is 0.20 ms cm^{-1} .

- (i) Use Fig. 8.2 to show that the frequency of the sound is approximately 1300 Hz.

[2]

- (ii) Explain how the apparatus is used to determine the wavelength of the sound.

.....
.....
.....
..... [2]

- (iii) The wavelength of the sound wave is 0.26 m. Calculate the speed of sound in this experiment.

speed = ms^{-1} [2]

BLANK PAGE

Permission to reproduce items where third-party owned material protected by copyright is included has been sought and cleared where possible. Every reasonable effort has been made by the publisher (UCLES) to trace copyright holders, but if any items requiring clearance have unwittingly been included, the publisher will be pleased to make amends at the earliest possible opportunity.

Cambridge International Examinations is part of the Cambridge Assessment Group. Cambridge Assessment is the brand name of University of Cambridge Local Examinations Syndicate (UCLES), which is itself a department of the University of Cambridge.