

1.

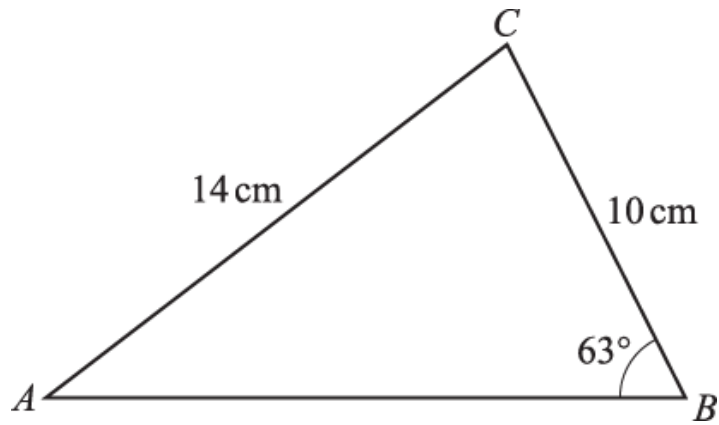

The diagram shows triangle  $ABC$ , with  $AC = 14$  cm,  $BC = 10$  cm and angle  $ABC = 63^\circ$ .

i. Find angle  $CAB$ .

[2]

ii. Find the length of  $AB$ .

[2]

2.

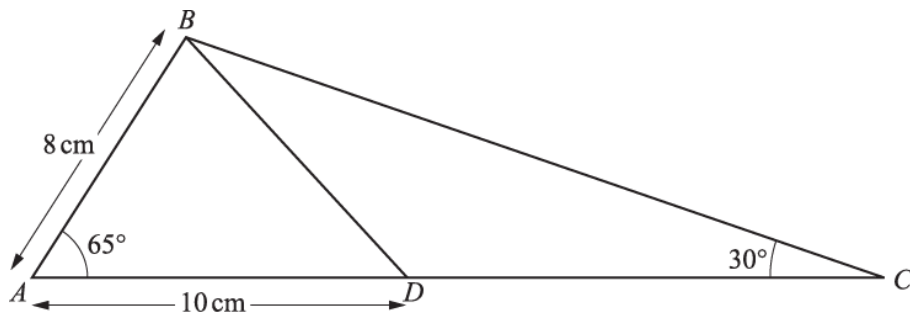

The diagram shows triangle  $ABC$ , with  $AB = 8$  cm, angle  $BAC = 65^\circ$  and angle  $BCA = 30^\circ$ . The point  $D$  is on  $AC$  such that  $AD = 10$  cm.

i. Find the area of triangle  $ABD$ .

[2]

ii. Find the length of  $BD$ .

[2]

iii. Find the length of  $BC$ .

[2]

3.

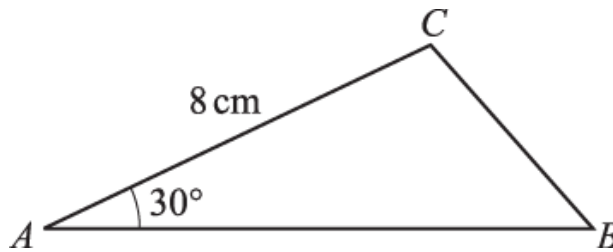

The diagram shows triangle  $ABC$ , with  $AC = 8$  cm and angle  $CAB = 30^\circ$ .

- i. Given that the area of the triangle is  $20 \text{ cm}^2$ , find the length of  $AB$ .

[2]

- ii. Find the length of  $BC$ , giving your answer correct to 3 significant figures.

[2]

4. The points  $P$ ,  $Q$  and  $R$  have coordinates  $(-1, 6)$ ,  $(2, 10)$  and  $(11, 1)$  respectively. Find the angle  $PRQ$ .

[4]

5. In this question you must show detailed reasoning.

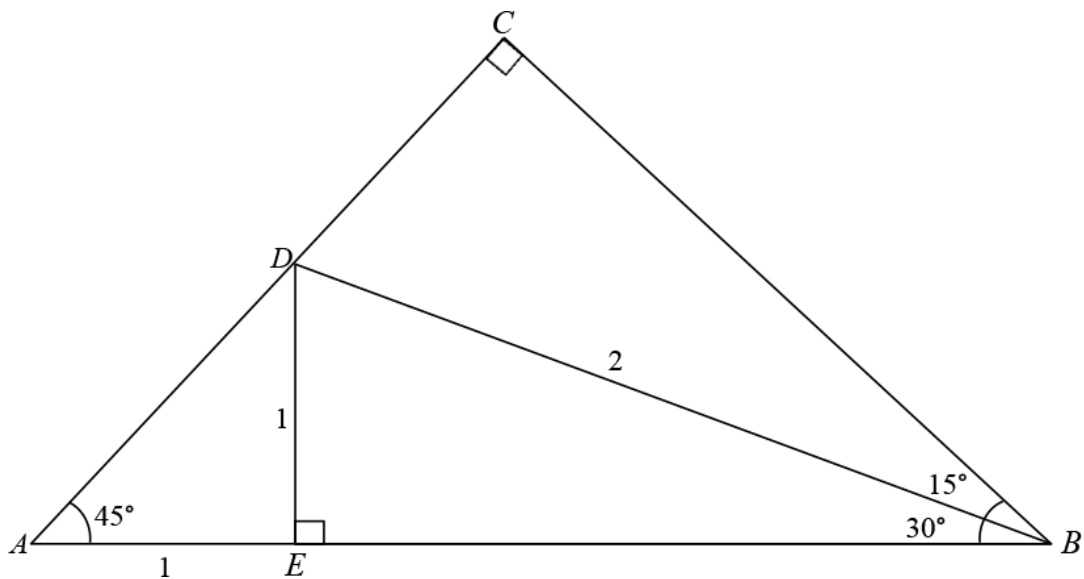

The diagram shows triangle  $ABC$ . The angles  $CAB$  and  $ABC$  are each  $45^\circ$ , and angle  $ACB = 90^\circ$ . The points  $D$  and  $E$  lie on  $AC$  and  $AB$  respectively, such that  $AE = DE = 1$ ,  $DB = 2$  and angle  $BED = 90^\circ$ . Angle  $EBD = 30^\circ$  and angle  $DBC = 15^\circ$ .

(a) Show that 
$$BC = \frac{\sqrt{2} + \sqrt{6}}{2}.$$

[3]

(b) By considering triangle  $BCD$ , show that 
$$\sin 15^\circ = \frac{\sqrt{6} - \sqrt{2}}{4}.$$

[3]

6.

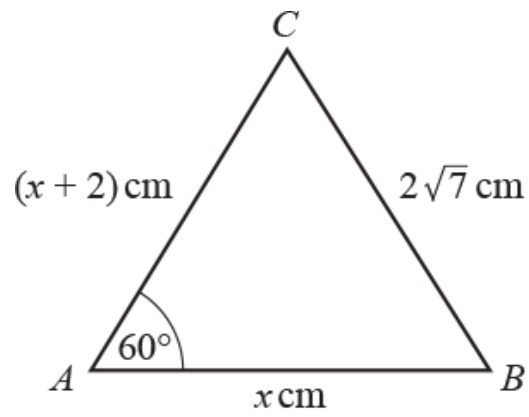

The diagram shows triangle  $ABC$ , with  $AB = x \text{ cm}$ ,  $AC = (x + 2) \text{ cm}$ ,  $BC = 2\sqrt{7} \text{ cm}$  and angle  $CAB = 60^\circ$ .

(a) Find the value of  $x$ . [4]

(b) Find the area of triangle  $ABC$ , giving your answer in an exact form as simply as possible. [2]

END OF QUESTION paper

# Mark scheme

| Question | Answer/Indicative content   | Marks               | Part marks and guidance   |   |
|----------|---|---------------------|---|---|
| 1        | <p>i</p> $\frac{\sin A}{10} = \frac{\sin 63}{14}$ $A = 39.5^\circ$ <p>ii</p>                | <p>M1</p> <p>A1</p> | <p>Attempt use of correct sine rule</p> <p>Obtain <math>39.5^\circ</math>, or better</p>    | <p>Must be correct sine rule, either way up<br/>Need to rearrange at least as far as <math>\sin A = \dots</math>, using a valid method<br/>Allow M1 even if subsequently evaluated in rads (0.120)</p> <p>Actual answer is <math>39.52636581\dots</math> so allow more accurate answer as long as it rounds to <math>39.53</math></p> <p><b>Examiner's Comments</b></p> <p>This proved to be a straightforward question, and most candidates used the sine rule accurately to gain full marks.</p>  |
|          | <p>ii</p> $c^2 = 10^2 + 14^2 - 2 \times 10 \times 14 \times \cos 77.5^\circ \quad c = 15.3$ | <p>M1</p>           | <p>Attempt use of correct cosine rule, or equiv, inc attempt at <math>77.5^\circ</math></p> | <p>Angle used must be <math>77.5^\circ</math> or must come from a clear attempt at <math>180 - (63 + \text{their } A)</math>. <b>NB</b><br/>Using <math>102.5^\circ</math> in sine rule will give 15.3, but this is M0.<br/>Must be correct formula seen or implied, but allow slip when evaluating eg omission of 2, incorrect extra 'big bracket'<br/>Allow M1 if expression is not square rooted, as long as LHS was intended to be correct ie <math>c^2 = \dots</math> or <math>AB^2 = \dots</math><br/>Allow M1 even if subsequently evaluated in rad mode<br/>Allow any equiv method, including sine rule (as far as <math>\sin C = \dots</math>) or right-angled</p> |

|              |  |    |  |          |   |  |
|--------------|--|----|--|----------|---|--|
|              |  |    |  |          |   | <p>triangle trig (must be full and valid method)</p> <p>Allow more accurate answer as long as it rounds to 15.34</p> <p><b>Examiner's Comments</b></p> <p>Most candidates were also successful in this part of the question, with either the sine rule or the cosine rule being used accurately. Some candidates lost the accuracy mark through using a rounded value from part (i), and others lost both marks through using the wrong angle.</p> |
|              |  | ii |  | A1       | Obtain 15.3, or better  |  |
| <b>Total</b> |  |    |  | <b>4</b> |   |  |
| 2            |  | i  | <p>area = <math>\frac{1}{2} \times 8 \times 10 \times \sin 65^\circ</math></p> <p>= 36.3</p> | M1       | <p>Attempt area of triangle using <math>\frac{1}{2} ab \sin \theta</math></p> <p>Obtain 36.3, or better</p> <p><b>Examiner's Comments</b></p> <p>This entire question proved to be a very straightforward start to the paper and most candidates gained all of the 6 marks available. In this part of the question the majority of candidates could quote the correct formula, though a few omitted the <math>\frac{1}{2}</math>. Other errors included evaluating the expression in the incorrect calculator mode and incorrect rounding. These are all avoidable errors and candidates should be alert to them.</p> | <p>Must be correct formula, including <math>\frac{1}{2}</math></p> <p>Allow if evaluated in radian mode (gives 33.1)</p> <p>If using <math>\frac{1}{2} \times b \times h</math>, then must be valid use of trig to find <math>h</math></p> <p>If &gt; 3sf, allow answer rounding to 36.25 with no errors seen</p>  |
|              |  | ii | $BD^2 = 8^2 + 10^2 - 2 \times 8 \times 10 \times \cos 65^\circ$                              | M1       | Attempt use of correct cosine rule  | <p>Must be correct cosine rule</p> <p>Allow M1 if not square rooted, as long as <math>BD^2</math></p>  |

|  |  |  |                     |   |  |
|--|--|--|---------------------|---|--|
|  |  | <p>ii <math>BD = 9.82</math></p>   | <p>A1</p>           | <p>Obtain 9.82, or better</p> <p><b>Examiner's Comments</b></p> <p>This was also very well done, with candidates able to either quote the correct formula or obtain it from the formula book. Candidates could identify which sides to use and the substitution was nearly always correct. A few candidates then spoiled their answer by inserting imaginary brackets to treat the whole expression as a coefficient of <math>\cos 65^\circ</math>. Once again, marks were sometimes lost through incorrect calculator mode or rounding errors.</p> | <p>seen</p> <p>Allow if evaluated in radian mode (gives 15.9)</p> <p>Allow if correct formula is seen but is then evaluated incorrectly - using <math>(8^2 + 10^2 - 2 \times 8 \times 10) \times \cos 65^\circ</math> gives 1.30</p> <p>Allow any equiv method, as long as valid use of trig</p> <p>If &gt; 3sf, allow answer rounding to 9.817 with no errors seen</p>  |
|  |  | <p>iii <math>\frac{BC}{\sin 65} = \frac{8}{\sin 30}</math></p> <p>iii <math>BC = 14.5</math></p> | <p>M1</p> <p>A1</p> | <p>Attempt use of correct sine rule (or equiv)</p> <p>Obtain 14.5, or better</p> <p><b>Examiner's Comments</b></p> <p>The better candidates simply used triangle <math>ABC</math> and found the required length through efficient use of the Sine Rule. A surprising number decided instead to use a multi-step method working first of all within triangle <math>ABD</math> and then attempting the length of <math>BC</math>, possibly from</p>   | <p>Must get as far as attempting <math>BC</math>, not just quoting correct sine rule</p> <p>Allow any equiv method, as long as valid use of trig including attempt at any angles used</p> <p>If using their <math>BD</math> from part (ii) it must have been a valid attempt (eg M0 for <math>BD = 8 \sin 65</math>, <math>BC = \frac{BD}{\sin 30} = 14.5</math>)</p> <p>If &gt; 3sf, allow answer rounding to 14.5 with no errors in method seen</p> <p>In multi-step solutions (eg using 9.82) interim values may be slightly inaccurate – allow A1 if answer rounds to 14.5</p> |

|   |    |   |              |  |   |
|---|----|---|--------------|--|---|
|   |    |   |              |  | assuming that part (ii) should be used. This was usually done correctly, but the extra steps did sometimes result in a loss of accuracy in the final answer.  |
|   |    |   | <b>Total</b> | <b>6</b>   |   |
| 3 | i  | $\frac{1}{2} \times 8 \times AB \times \sin 30 = 20$ $AB = 10$        | M1           | Equate correct attempt at area of triangle to 20     | <p>Must be using correct formula, including <math>\frac{1}{2}</math></p> <p>Allow if subsequently evaluated in radian mode (gives <math>-3.95AB = 20</math>)</p> <p>If using <math>\frac{1}{2} \times b \times h</math> then must be valid use of trig to find <math>h</math></p> <p>Must be exactly 10</p> <p><b>Examiner's Comments</b></p> <p>This was a straightforward start to the paper, and nearly all of the candidates were able to find the correct value for the length. The most common and efficient approach was to use the sine rule, but other methods were also employed. As ever, a few candidates worked with their calculator in radian mode, and persisted with their solution despite it resulting in a negative length. As always, candidates should check the reasonableness of their answer and review their method if necessary.</p> |
|   | ii | $BC^2 = 8^2 + 10^2 - 2 \times 8 \times 10 \times \cos 30$ $BC = 5.04$ | M1           | Attempt to use correct cosine rule, using their $AB$ | <p>Must be using correct cosine rule</p> <p>Allow M1 if not square rooted, as long as <math>BC^2</math> soi</p> <p>Allow if subsequently evaluated in radian mode (gives 11.8), but</p>   |

|   |    |  |   |  |   |
|---|----|--|---|--|---|
|   |    |  |   |  | <p>11.8 by itself cannot imply M1</p> <p>Allow if correct formula seen but is then evaluated incorrectly (using <math>(8^2 + 10^2 - 2 \times 8 \times 10) \times \cos 30</math> gives 1.86)</p> <p>Allow any equiv method as long as valid use of trig</p> <p>If &gt; 3sf, allow answer rounding to 5.043 with no errors seen</p> <p><b>Examiner's Comments</b></p> <p>This part of the question was also very well answered by the majority of candidates, and full marks were very common. The cosine rule was usually quoted correctly, but candidates who are unsure should make use of the formula book. Some candidates were unable to correctly evaluate the expression with additional, incorrect, brackets being used or square rooting being omitted.</p> |
|   | ii |  | A1  | Obtain 5.04, or better   |   |
|   |    | <b>Total</b>   | <b>4</b>  |  |   |
| 4 |    | <p>e.g. <math>(2 - (-1))^2 + (10 - 6)^6</math></p> <p><math>PQ^2 = 25, QR^2 = 162, RP^2 = 169</math></p> $\angle PRQ = \cos^{-1} \frac{169 + 162 - 25}{2 \times 13 \times \sqrt{162}}$ <p>= 22.4 to 3 sf</p> | <p>M1 (AO3.1a)</p> <p>A1 (AO1.1)</p> <p>M1 (AO1.1)</p> <p>A1 (AO1.1)</p> <p>[4]</p> | <p>Find at least one of <math>PQ^2, QR^2</math> or <math>RP^2</math></p> <p>or <math>PQ, QP</math> or <math>QR</math> seen</p> <p>Use cosine rule to find an angle of triangle PQR</p> <p>Accept 3 sf or</p> |   |



|   |   |   |  |   |   |  |
|---|---|---|--|---|---|--|
|   |   |   |  |   | better<br>(22.38013503...)  |  |
|   |   | <b>Total</b>  | <b>4</b>   |   |   |  |
| 5 | a | <p>DR<br/> <math>BE = \sqrt{3}</math> from the standard triangle <math>BDE</math></p> <p><math>BC = AB \cos 45</math></p> $BC = \frac{1 + \sqrt{3}}{\sqrt{2}} = \frac{\sqrt{2} + \sqrt{6}}{2}$  | <p>B1(AO<br/>2.2a)</p> <p>M1(AO<br/>2.1)</p> <p>E1(AO<br/>2.2a)</p> <p>[3]</p> | <p>Or<br/> <math>AB = 1 + \sqrt{3}</math><br/> seen</p> <p>oe or<br/> Pythagoras'<br/> theorem<br/> AG</p>  | <p>B0 for<br/> decimal</p> <p>Must be<br/> seen<br/> <math>\frac{1 + \sqrt{3}}{\sqrt{2}}</math><br/> must be<br/> seen.</p> |  |
|   | b | <p>DR<br/> Triangle <math>ABC</math> is isosceles so <math>BC = AC</math> but</p> $AC = CD + \sqrt{2}$ <p>so <math>CD = \frac{\sqrt{2} + \sqrt{6}}{2} - \sqrt{2}</math></p> $= \frac{\sqrt{6} - \sqrt{2}}{2}$ <p>sin15</p> $= \frac{CD}{BD} = \frac{\sqrt{6} - \sqrt{2}}{2} \div 2 = \frac{\sqrt{6} - \sqrt{2}}{4}$ | <p>B1(AO<br/>2.4)</p> <p>M1(AO<br/>2.1)</p> <p>A1(AO<br/>2.2a)</p> <p>[3]</p>  | <p>State or imply<br/> that <math>BC = AC</math><br/> and state<br/> <math>AC = CD + \sqrt{2}</math><br/> Obtain<br/> expression for<br/> <math>CD</math>, may be<br/> unsimplified</p> <p>Obtain<br/> expression for<br/> sin15 and<br/> simplify to<br/> answer given</p> | <p>M0 if<br/> decimals<br/> seen</p> <p>SC1 for<br/> showing<br/> using<br/> addition<br/> formula</p>                      |  |
|   |   | <b>Total</b>  | <b>6</b>   |   |   |  |
| 6 | i | $(2\sqrt{7})^2 = x^2 + (x+2)^2 - 2x(x+2)\cos 60$<br>$x^2 + 2x - 24 = 0$<br>$(x+6)(x-4) = 0$<br>$x = 4$  | M1   | <p>Attempt use<br/> of correct<br/> cosine rule</p>   | <p>Must be<br/> attempt to<br/> use correct<br/> rule but<br/> allow BOD<br/> on lack of<br/> brackets eg</p>               |  |

|  |  |    |  |  |   |
|--|--|----|--|--|---|
|  |  |    |  |  | <p><math>2\sqrt{7^2}</math> not <math>(2\sqrt{7})^2</math>, even if subsequently 14, and the same for the terms involving <math>x</math></p> <p>Allow omission of a square sign when substituting as long as correct formula has been seen</p> <p>No need to evaluate <math>\cos 60</math> for M1</p> <p>Evaluating in radian mode (<math>-0.952</math>) still can get M1 as long as <math>\cos 60</math> seen first</p> <p>Must be simplified to three terms but not necessarily all on one side of the equation</p> <p>See additional guidance for valid methods</p> <p>Must be from a correct solution of a correct quadratic,</p> |
|  |  | A1 |  |  |   |
|  |  | M1 | Obtain correct 3 term quadratic            |  |   |
|  |  | A1 | Attempt to solve 3 term quadratic equation |  |   |
|  |  |    | Obtain $x = 4$ only                        |  |   |

|  |  |     |  |  |
|--|--|-----|--|--|
|  |  | [4] | <p>though only the positive root may ever be seen<br/>         Could draw attention to required root by giving both answers and then eg underlining <math>x = 4</math><br/>         A0 if <math>x = -6</math> still present</p> <p>If the other root is stated, before being discarded, it must have been <math>x = -6</math></p>  |  |
|  |  |     | <p><b>Examiner's Comments</b></p> <p>This question proved to be a surprisingly challenging start to the paper. Most candidates were able to identify the need to use the cosine rule, and the majority of these gained one mark for stating a correct equation. Rearranging the equation was problematic for many, with a common error being for the <math>\cos 60^\circ</math> to be moved across to the other side of the equation independently of the rest of the product. The other common error was for the <math>\cos 60^\circ</math> to be applied only to the second term in the product, with <math>x(x + 2)\cos 60^\circ</math> becoming <math>x^2 + x</math>. Sign errors were also common. The most successful solutions made effective use of brackets throughout the entire question. Candidates who started with the version of the cosine rule where <math>\cos A</math> appears as the subject tended to be more successful in obtaining the correct quadratic. Candidates who obtained the quadratic equation were invariably able to solve it correctly, and also appreciate that the negative solution should be discarded.</p> |  |

|  |  |  |                                |   |  |  |  |
|--|--|--|--------------------------------|---|--|--|--|
|  |  | <p>ii</p> $\frac{1}{2} \times 4 \times 6 \times \sin 60$ $= 6\sqrt{3}$ | <p>M1</p> <p>A1</p> <p>[2]</p> | <table border="1"> <tr> <td data-bbox="823 107 1038 1411"> <p>Attempt area of the triangle, using their <math>x</math></p> <p>Obtain <math>6\sqrt{3}</math></p> </td> <td data-bbox="1038 107 1254 1411"> <p>Must be using correct formula, including <math>\frac{1}{2}</math> Allow equiv methods, such as <math>\frac{1}{2}bh</math> as long as valid attempt at <math>b</math> and <math>h</math> Must be using a positive, numerical, value of <math>x</math> from (i)</p> <p>Must be given as simplified surd No ISW if then given as decimal, unless the exact value is indicated as the final answer (underlined etc)</p> </td> </tr> </table> | <p>Attempt area of the triangle, using their <math>x</math></p> <p>Obtain <math>6\sqrt{3}</math></p> | <p>Must be using correct formula, including <math>\frac{1}{2}</math> Allow equiv methods, such as <math>\frac{1}{2}bh</math> as long as valid attempt at <math>b</math> and <math>h</math> Must be using a positive, numerical, value of <math>x</math> from (i)</p> <p>Must be given as simplified surd No ISW if then given as decimal, unless the exact value is indicated as the final answer (underlined etc)</p> |  |
| <p>Attempt area of the triangle, using their <math>x</math></p> <p>Obtain <math>6\sqrt{3}</math></p> | <p>Must be using correct formula, including <math>\frac{1}{2}</math> Allow equiv methods, such as <math>\frac{1}{2}bh</math> as long as valid attempt at <math>b</math> and <math>h</math> Must be using a positive, numerical, value of <math>x</math> from (i)</p> <p>Must be given as simplified surd No ISW if then given as decimal, unless the exact value is indicated as the final answer (underlined etc)</p> |  |                                |   |  |  |  |
|  |  | <p>Total</p>   | <p>6</p>                       | <p><b>Examiner's Comments</b></p> <p>The majority of the candidates were able to quote the correct formula for the area of a non-right angled triangle, and correctly use their value of <math>x</math>.</p>  |  |  |  |