

1. The diagram represents a vertical flagpole, AB .
The flagpole is supported by two ropes, BC and BD , fixed to the horizontal ground at C and at D .

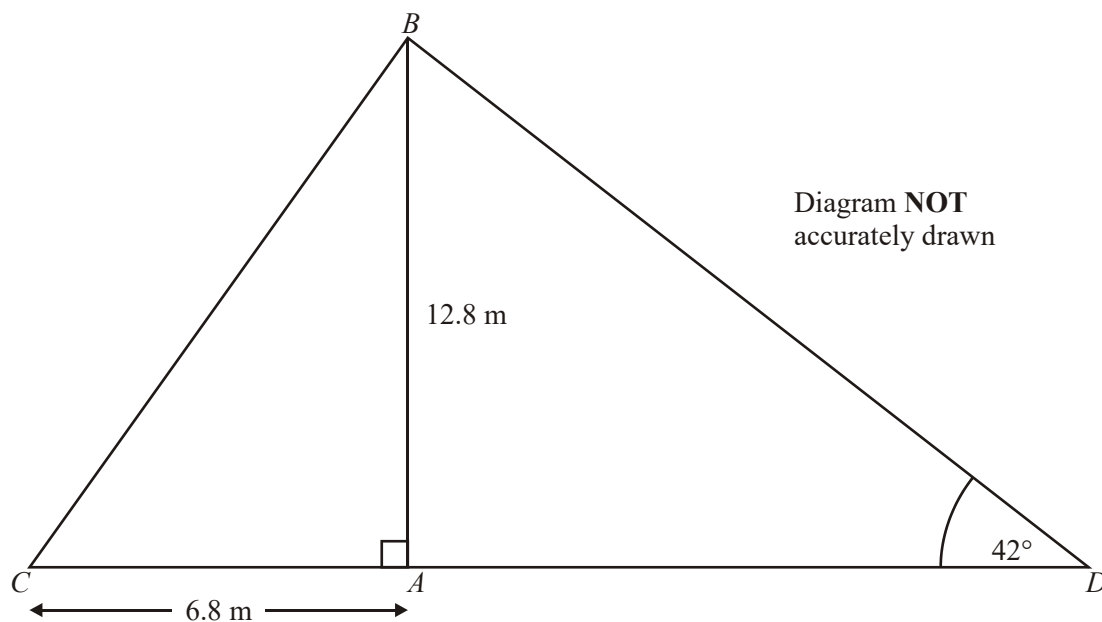

$AB = 12.8$ m.
 $AC = 6.8$ m.
 Angle $BDA = 42^\circ$.

- (a) Calculate the size of angle BCA .
Give your answer correct to 3 significant figures.

.....°

(3)

- (b) Calculate the length of the rope BD .
Give your answer correct to 3 significant figures.

..... m
(3)
(Total 6 marks)

2.

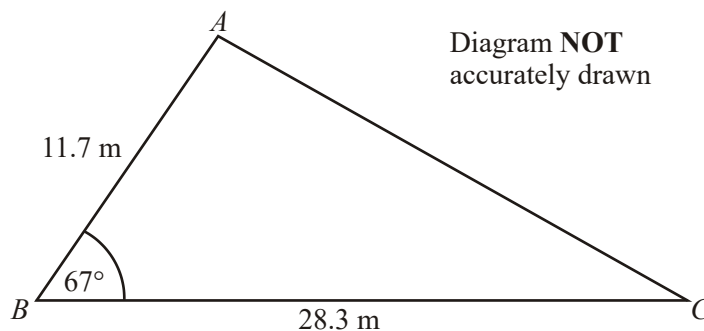

$AB = 11.7$ m.
 $BC = 28.3$ m.
Angle $ABC = 67^\circ$.

- (a) Calculate the area of the triangle ABC .
Give your answer correct to 3 significant figures.

..... m^2
(2)

- (b) Calculate the length of AC .
Give your answer correct to 3 significant figures.

..... m

(3)

(Total 5 marks)

3. The depth, D metres, of the water at the end of a jetty in the afternoon can be modelled by this formula

$$D = 5.5 + A \sin 30(t - k)^\circ$$

where

t hours is the number of hours after midday,
 A and k are constants.

Yesterday the low tide was at 3 p.m.
The depth of water at low tide was 3.5 m.

Find the value of A and k .

$A = \dots\dots\dots$

$k = \dots\dots\dots$

(Total 4 marks)

4. A sketch of the curve $y = \sin x^\circ$ for $0 \leq x \leq 360$ is shown below.

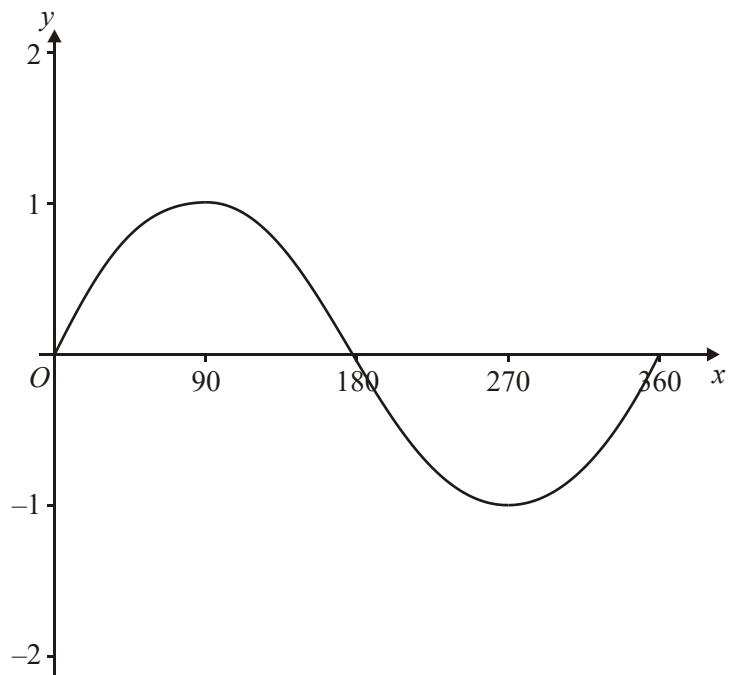

- (a) Using the sketch above, or otherwise, find the equation of each of the following two curves.

(i)

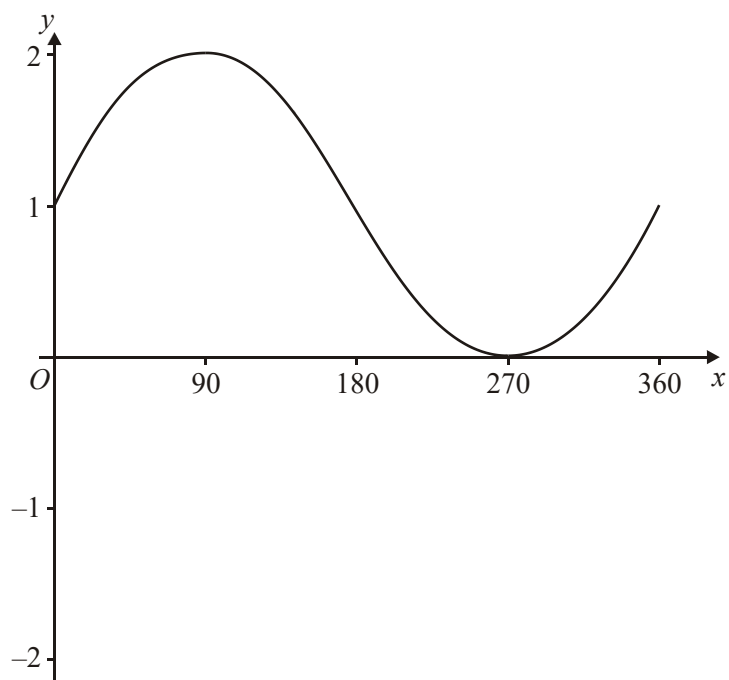

(i) Equation $y = \dots\dots\dots$

(ii)

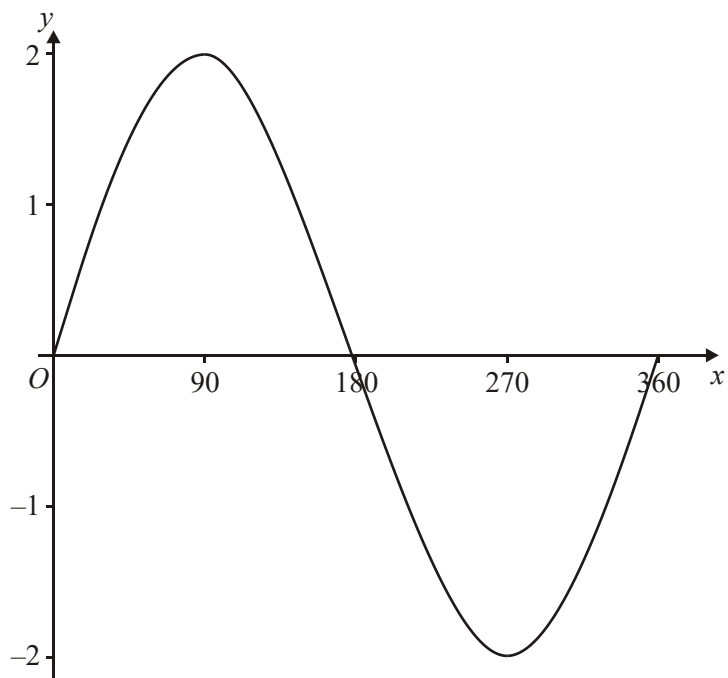

(ii) Equation $y = \dots\dots\dots$

(2)

(b) Describe fully the sequence of two transformations that maps the graph of $y = \sin x^\circ$ onto the graph of $y = 3 \sin 2x^\circ$

.....

.....

.....

.....

(3)

(Total 5 marks)

5.

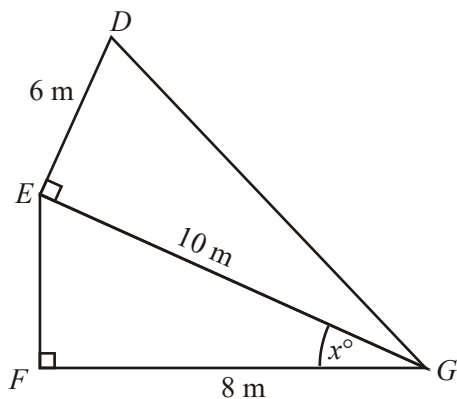

Diagram **NOT** accurately drawn

$DE = 6\text{ m}$.
 $EG = 10\text{ m}$.
 $FG = 8\text{ m}$.
 Angle $DEG = 90^\circ$. Angle $EFG = 90^\circ$.

- (a) Calculate the length of DG .
 Give your answer correct to 3 significant figures.

..... m (3)

- (b) Calculate the size of the angle marked x° .
 Give your answer correct to one decimal place.

.....^o (3)
 (Total 6 marks)

6.

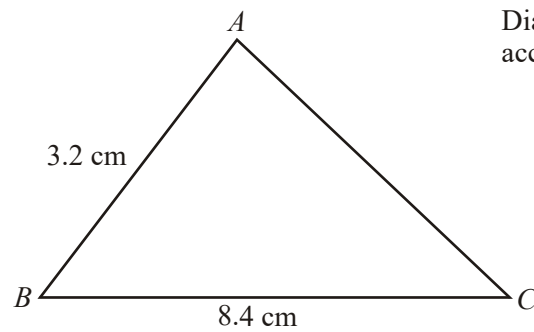

Diagram **NOT**
accurately drawn

$$AB = 3.2 \text{ cm}$$

$$BC = 8.4 \text{ cm}$$

The area of triangle ABC is 10 cm^2 .

Calculate the perimeter of triangle ABC .

Give your answer correct to three significant figures.

..... cm
(Total 6 marks)

7.

$$y = \sqrt{\frac{r + t \sin x^\circ}{r - t \sin x^\circ}}$$

$$r = 8.8$$

$$t = 7.2$$

$$x = 40$$

Calculate the value of y . Give your answer correct to 3 significant figures.

$y = \dots\dots\dots$
(Total 3 marks)

8. In triangle PQR ,
 $PQ = 10$ cm.
 $QR = 12$ cm.
 Angle $PQR = 45^\circ$.

- (a) Calculate the area of triangle PQR .
 Give your answer correct to 3 significant figures.

$\dots\dots\dots \text{cm}^2$
(2)

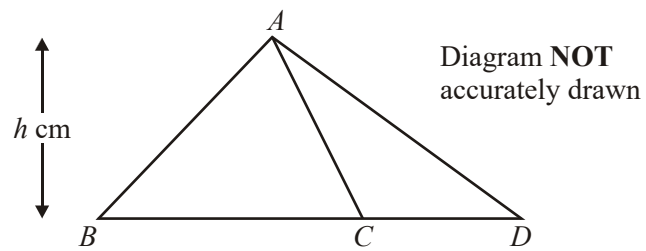

The diagram shows triangle ABC and triangle ACD .
 BCD is a straight line.
The perpendicular distance from A to the line BCD is h cm.

- (b) Explain why $\frac{\text{area of triangle } ABC}{\text{area of triangle } ACD} = \frac{BC}{CD}$

(2)

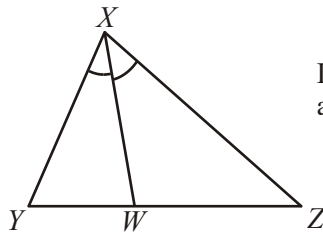

Diagram **NOT**
accurately drawn

The diagram shows triangle XYZ .

W is the point on YZ such that angle $YXW =$ angle WXZ .

- (c) Using expressions for the area of triangle YXW and the area of triangle WXZ , or otherwise, show that

$$\frac{XY}{XZ} = \frac{YW}{WZ}$$

(3)
(Total 7 marks)

9. A lighthouse, L , is 3.2 km due West of a port, P .
 A ship, S , is 1.9 km due North of the lighthouse, L .

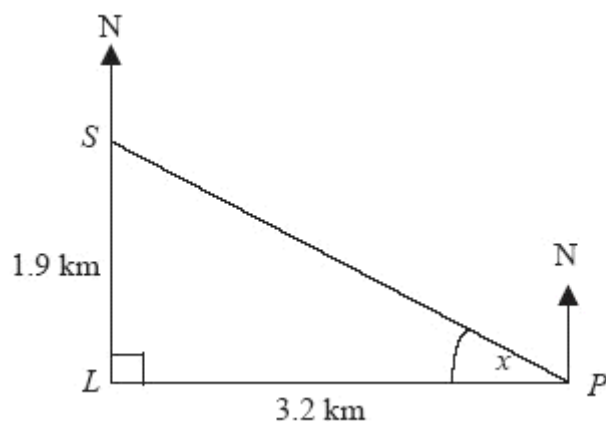

Diagram NOT accurately drawn

- (a) Calculate the size of the angle marked x .
 Give your answer correct to 3 significant figures.

$x = \dots\dots\dots^\circ$ (3)

- (b) Find the bearing of the port, P , from the ship, S .
 Give your answer correct to 3 significant figures.

$\dots\dots\dots^\circ$ (1)
 (Total 4 marks)

10.

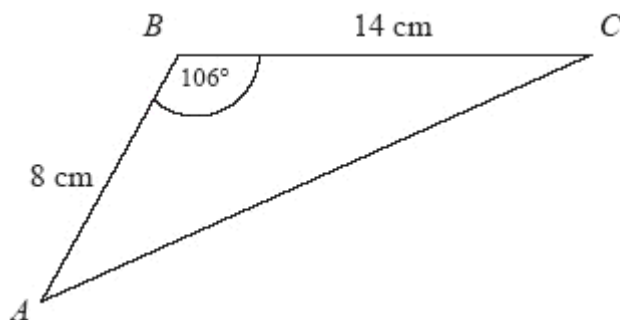

Diagram **NOT**
accurately drawn

ABC is a triangle.

$AB = 8$ cm

$BC = 14$ cm

Angle $ABC = 106^\circ$

Calculate the area of the triangle.

Give your answer correct to 3 significant figures.

.....cm²
(Total 3 marks)

11. The diagram shows some of the markings on a baseball field.

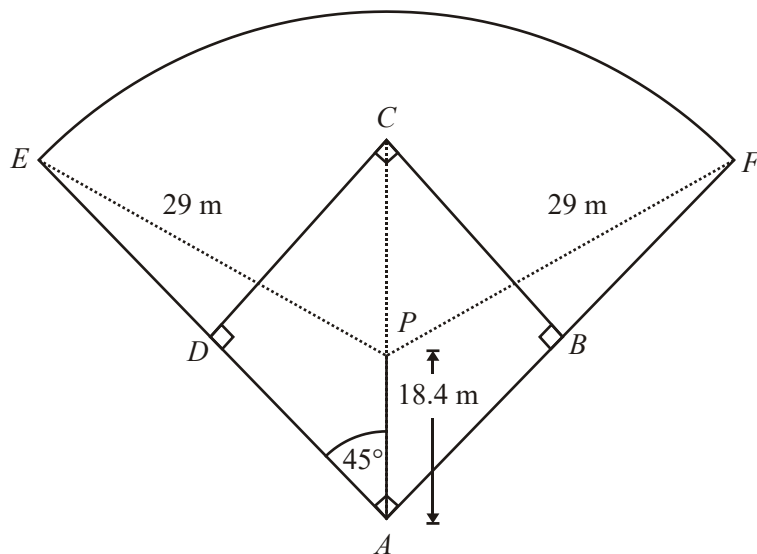

Diagram **NOT** accurately drawn

$ABCD$ is a square.
 AC is a diagonal of $ABCD$.
 P is a point on AC .
 ADE and ABF are straight lines.

$AP = 18.4$ m.
 Angle $PAE = 45^\circ$.

EF is an arc of the circle, centre P and radius 29 m.

- (a) By considering triangle PAE , calculate the size of angle AEP .
 Give your answer correct to 3 significant figures.

.....^o

(3)

- (b) Calculate the length of the arc EF .
Give your answer correct to 3 significant figures.

..... m
(4)
(Total 7 marks)

12. (a) Calculate the size of angle a in this right-angled triangle.
Give your answer correct to 3 significant figures.

Diagram **NOT** accurately drawn

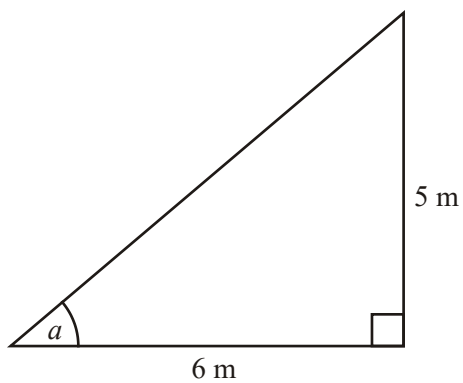

.....°
(3)

- (b) Calculate the length of the side x in this right-angled triangle.
Give your answer correct to 3 significant figures.

Diagram **NOT** accurately drawn

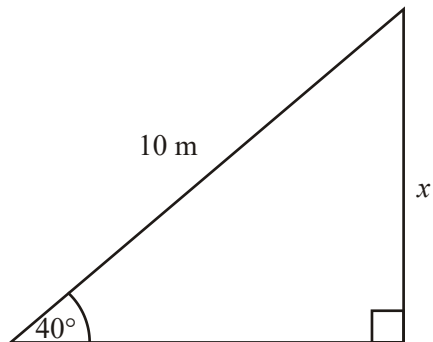

..... cm

(3)
(Total 6 marks)

13.

Diagram **NOT** accurately drawn

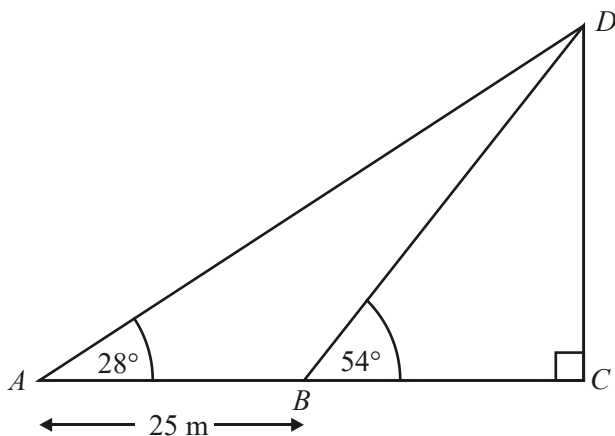

The diagram shows a vertical tower DC on horizontal ground ABC .
 ABC is a straight line.

The angle of elevation of D from A is 28° .
The angle of elevation of D from B is 54° .

$AB = 25$ m.

Calculate the height of the tower.
Give your answer correct to 3 significant figures.

..... m
(Total 5 marks)

14.

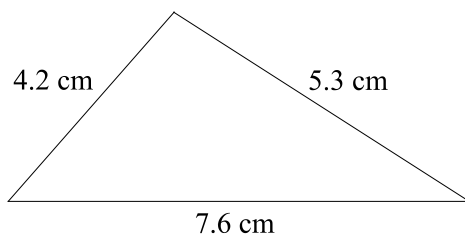

Diagram **NOT** accurately drawn

The lengths of the sides of a triangle are 4.2 cm, 5.3 cm and 7.6 cm.

- (a) Calculate the size of the largest angle of the triangle.
Give your answer correct to 1 decimal place.

.....° (3)

- (b) Calculate the area of the triangle.
Give your answer correct to 3 significant figures.

..... cm² (3)
(Total 6 marks)

15.

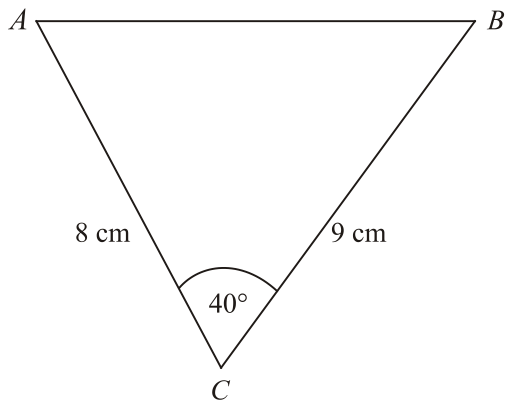

Diagram **NOT**
accurately drawn

ABC is a triangle.

$AC = 8$ cm.

$BC = 9$ cm.

Angle $ACB = 40^\circ$.

Calculate the length of AB .

Give your answer correct to 3 significant figures.

..... cm
(Total 3 marks)

16. The diagram shows an equilateral triangle.

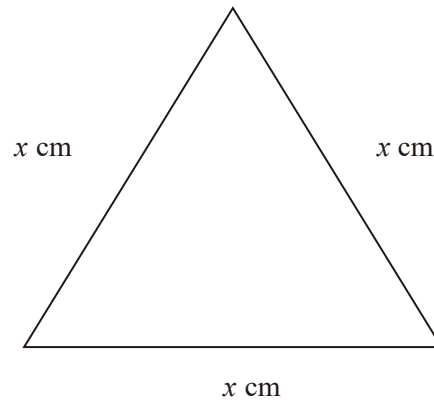

Diagram **NOT**
accurately drawn

The area of the equilateral triangle is 36 cm^2 .

Find the value of x .

Give your answer correct to 3 significant figures.

$x = \dots\dots\dots$

(Total 3 marks)

17.

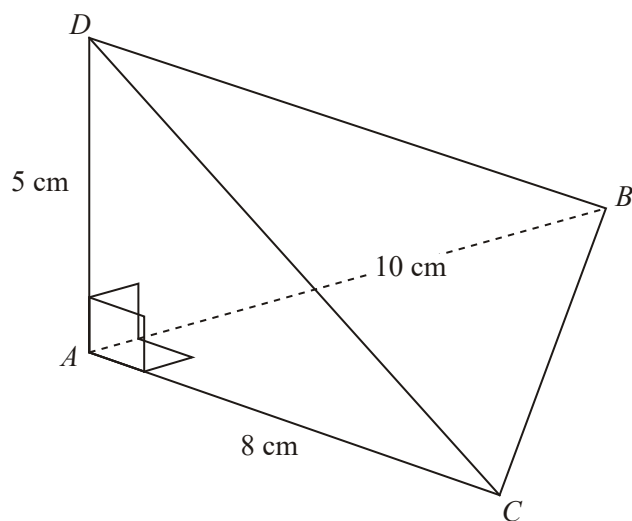

Diagram **NOT**
accurately drawn

The diagram shows a tetrahedron.
 AD is perpendicular to both AB and AC .
 $AB = 10$ cm.
 $AC = 8$ cm.
 $AD = 5$ cm.
 Angle $BAC = 90^\circ$.

Calculate the size of angle BDC .
 Give your answer correct to 1 decimal place.

.....
 (Total 6 marks)

18.

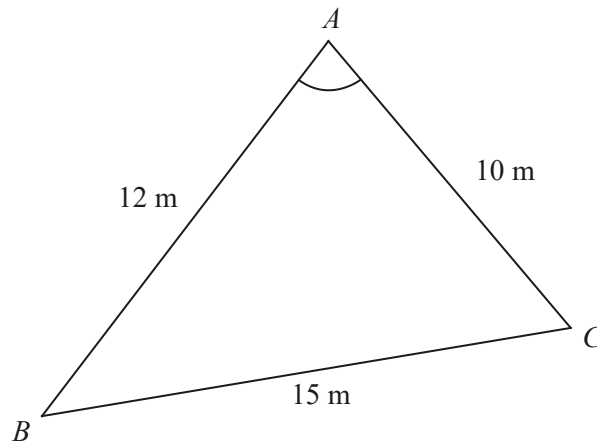
Diagram **NOT** accurately drawn

ABC is a triangle.
 $AB = 12\text{ m}$.
 $AC = 10\text{ m}$.
 $BC = 15\text{ m}$.

Calculate the size of angle BAC .
Give your answer correct to one decimal place.

.....°
(Total 3 marks)

19.

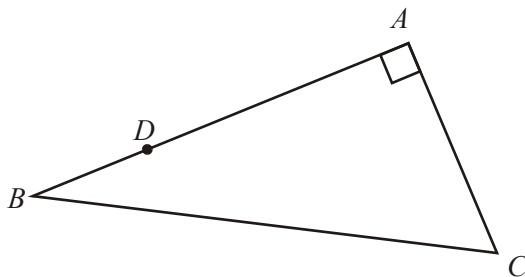
Diagram **NOT** accurately drawn

ABC is a right angled triangle.

D is the point on AB such that $AD = 3DB$.

$AC = 2DB$ and angle $A = 90^\circ$.

Show that $\sin C = \frac{k}{\sqrt{20}}$, where k is an integer.

Write down the value of k .

$k = \dots\dots\dots$
(Total 4 marks)

20.

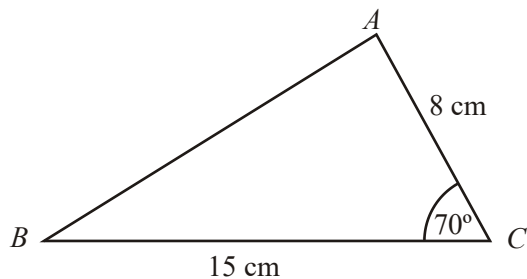

Diagram **NOT** accurately drawn

In triangle ABC ,
 $AC = 8$ cm,
 $BC = 15$ cm,
 Angle $ACB = 70^\circ$.

- (a) Calculate the length of AB .
 Give your answer correct to 3 significant figures.

..... cm

(3)

- (b) Calculate the size of angle BAC .
 Give your answer correct to 1 decimal place.

.....°

(2)

(Total 5 marks)

21.

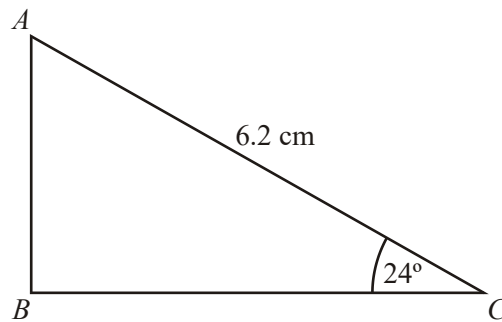
Diagram **NOT** accurately drawnAngle $ABC = 90^\circ$.Angle $ACB = 24^\circ$. $AC = 6.2$ cm.Calculate the length of BC .

Give your answer correct to 3 significant figures.

..... cm
(Total 3 marks)

22. A lighthouse, L , is 3.2 km due West of a port, P .
A ship, S , is 1.9 km due North of the lighthouse, L .

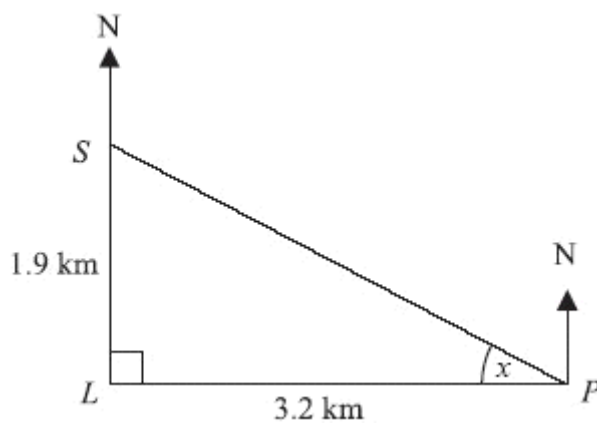
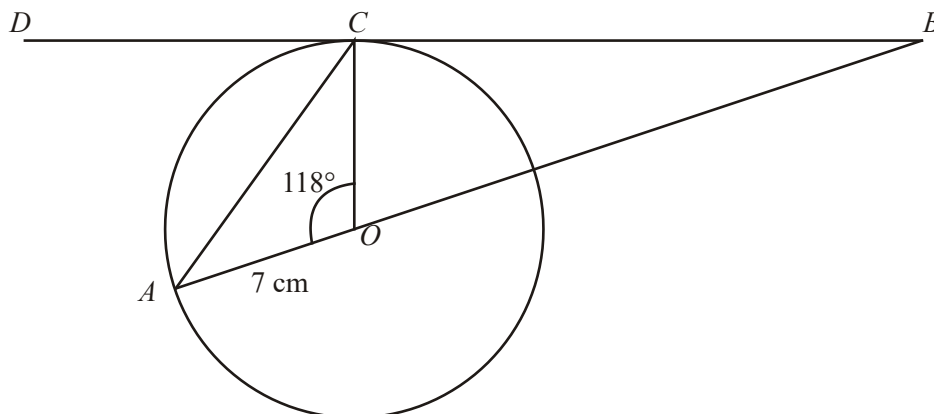

Diagram **NOT** accurately drawn

Calculate the size of the angle marked x .
Give your answer correct to 3 significant figures.

$x = \dots\dots\dots^\circ$
(Total 3 marks)

23.

Diagram **NOT**
accurately drawn

A and C are points on a circle, centre O .

DCB is the tangent to the circle at C .

AOB is a straight line.

$OA = 7$ cm.

Angle $AOC = 118^\circ$.

Work out the length of OB .

Give your answer correct to 3 significant figures.

$OB = \dots\dots\dots$ cm
(Total 4 marks)

24.

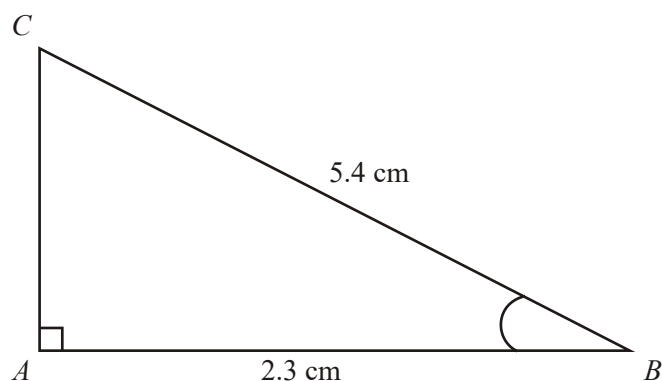
Diagram **NOT** accurately drawn

ABC is a right-angled triangle.

Angle $A = 90^\circ$.

$AB = 2.3$ cm.

$BC = 5.4$ cm.

Work out the size of angle B .

Give your answer correct to 3 significant figures.

.....[°]
(Total 3 marks)

25. Work out $\frac{\sqrt{2.56 + \sin 57^\circ}}{8.765 - 6.78}$

(a) Write down all the figures on your calculator display.

.....
(2)

(b) Give your answer to part (a) to an appropriate degree of accuracy.

.....
(1)
(Total 3 marks)

26. Calculate the length of the side marked x in this right-angled triangle.
Give your answer correct to 3 significant figures.

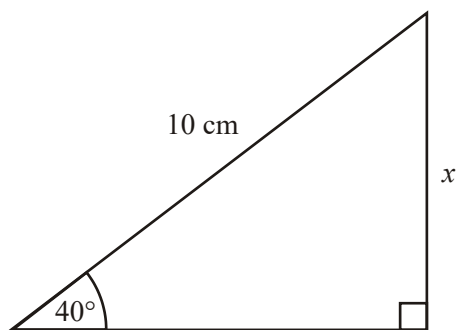

Diagram **NOT** accurately drawn

.....cm
(Total 3 marks)

- 27.

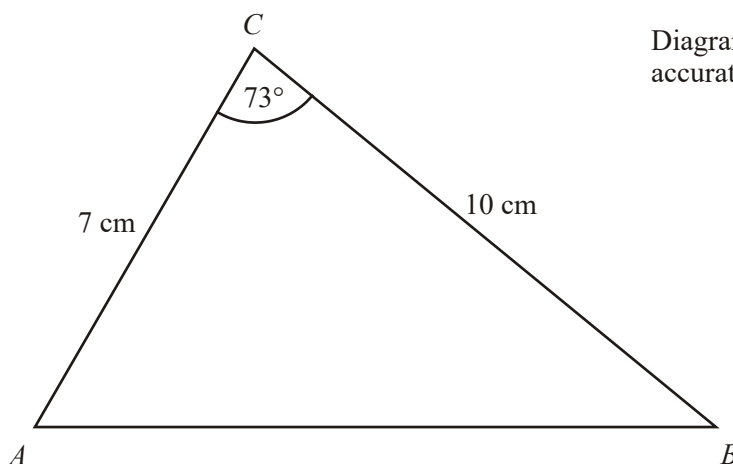

Diagram **NOT** accurately drawn

In triangle ABC ,
 $AC = 7$ cm,
 $BC = 10$ cm,
angle $ACB = 73^\circ$.

Calculate the length of AB .
Give your answer correct to 3 significant figures.

..... cm
(Total 3 marks)

1. (a) 62.0° 3

$$\tan ACB = \frac{12.8}{6.8}$$

$$x = \tan^{-1}(1.88)$$

$$M1 \text{ for } \tan C = \frac{12.8}{6.8}$$

$$M1 \text{ (dep) for } x = \tan^{-1}(\text{"1.88"})$$

$$A1 \text{ for } 62^\circ \text{ to } 62.021^\circ$$

For methods using the sine rule, a fully correct Pythagoras

followed by the sine rule to get $\sin C = \frac{12.8}{14.49}$ is needed for M1

- (b) 19.1m 3

$$BD = \frac{12.8}{\sin 42}$$

$$M1 \text{ for correct use of sin, } \sin 42^\circ = \frac{12.8}{BD}$$

$$M1 \text{ for } \frac{12.8}{\sin 42^\circ}$$

$$A1 \text{ for } 19.1 \text{ to } 19.13$$

[6]

2. (a) 152 2

$$\frac{1}{2} \times 11.7 \times 28.3 \times \sin 67$$

MI for $\frac{1}{2} \times 11.7 \times 28.3 \times \sin 67$

AI 152 to 152.4

(b) 26.1 3

$$AC^2 = 11.7^2 + 28.3^2 - 2 \times 11.7 \times 28.3 \times \cos 67$$

$$AC^2 = 937.8 - 258.7 = 679.1$$

MI for correct substitution into cosine rule

MI (dep) for correct order of evaluation

AI 26.05 – 26.1

[5]

3. $A = \pm 2$
 $k = 6$ 4

$$3.5 = 5.5 + A \sin 30(3 - k)$$

$$3.5 = 5.5 \pm A$$

MI for $3.5 = 5.5 + A \sin 30(3 - k)$

BI for one of max/min value of $\sin = +1/-1$

AI for $A = 2$ or -2

AI for $k =$ any multiple of 6 consistent with A

$A = 2, k = 6$ etc

$A = 2, k = 6(2n + 1)$

$A = -2, k = 12n$

4. (a) (i) $y = 1 + \sin x$ 2
BI for $y = 1 + \sin x$

(ii) $y = 2 \sin x$

BI for $y = 2 \sin x$

SC both (i) $f(x) + 1$, (ii) $2f(x)$ BI

(b) Stretch parallel to y-axis scale factor 3 3

Stretch parallel to x-axis scale factor $\frac{1}{2}$

MI for 'stretch'

AI for Stretch parallel to y-axis scale factor 3 oe

AI for Stretch parallel to x-axis scale factor $\frac{1}{2}$ oe

SC if M0 award BI for "sf 3 vertically" and "sf $\frac{1}{2}$ horizon."

[5]

5. (a) 11.7 3

$$10^2 + 6^2 \text{ or } 136$$

$$\sqrt{(100 + 36)} \text{ or } \sqrt{136} = 11.66\dots$$

MI for $10^2 + 6^2$ or 136 seen
MI (dep) $\sqrt{100 + 36}$ or $\sqrt{136}$
AI 11.66 – 11.7

(b) 36.9 3

$$\cos x = 8/10 \text{ or } 0.8$$

$$x = \cos^{-1} 0.8 = 36.869^\circ$$

MI for $\cos = \frac{8}{10}$, $\cos = 0.8$ (oe)
MI (dep) for \cos^{-1} (oe)
AI for 36.86 – 36.9
MI Use of sine rule and x found
MI for $x = 90 - \sin^{-1}("0.8")$
AI for 36.86 – 36.9

[6]

6. 18.3

6

$$0.5 \times 3.2 \times 8.4 \times \sin B = 10$$

$$\sin B = 0.74404\dots$$

$$48.077$$

$$AC^2 = 3.2^2 + 8.4^2 - 2 \times 3.2 \times 8.4 \times \cos B$$

$$AC^2 = 44.8815\dots$$

$$AC = 6.69 \text{ (936...)}$$

$$\text{Perimeter} = 18.3$$

Use the altitude AD , $\frac{h \times 8.4}{2} = 10 \Rightarrow h = (2.381)$

$$BD = \sqrt{3.2^2 - h^2} = 2.139$$

$$DC = 6.261$$

$$AC = \sqrt{2.38^2 + 6.261^2} = 6.69(936)$$

$$\text{Perimeter} = 18.3$$

MI for $0.5 \times 3.2 \times 8.4 \times \sin B (= 10)$

AI for $\sin B = 0.74(404\dots)$ or $B = 47.7 - 48.1$

MI for $3.2^2 + 8.4^2 - 2 \times 3.2 \times 8.4 \times \cos "48.077"$

MI(dep) for $AC^2 = "44.8(815)" \dots$ with correct order of evaluation

AI $AC = 6.69 - 6.7$

AI $18.29 - 18.3$

MI for $\frac{h \times 8.4}{2} = 10 \square h = (2.381)$

MI for $BD^2 = 3.2^2 - "2.381"{}^2$

AI $BD = 2.1 - 2.2$

MI (dep) $AC^2 = "2.381"{}^2 + "6.261"{}^2$

AI $AC = 6.69 - 6.7$

AI $18.29 - 18.3$

7. 1.79

3

$$\sqrt{\frac{8.8 + 7.2 \sin 40}{8.8 - 7.2 \sin 40}}$$

$$= \sqrt{\frac{13.428}{4.172}} = \sqrt{3.218}$$

M1 for correct substitution of all values into numerator or denominator (separately) condoning $\sin x 40$,

or for $\frac{40.72}{10.28} (= 3.96)$ or for $\frac{48.8}{8.8} (= 5.54)$

A1 for 13.4(28) or 4.1(72) or 3.2(18)

A1 1.79 - 1.8

[3]

8. (a) 42.4

2

$$0.5 \times 12 \times 10 \times \sin 45$$

M1 for $0.5 \times 12 \times 10 \times \sin 45$

A1 for 42.4 – 42.45

(b) AG

2

$$\text{Area } ABC = 0.5 \times BC \times h$$

$$\text{Area } CDB = 0.5 \times CD \times h$$

Let angle $YXW = t$

B1 for either $0.5 \times BC \times h$,

Or $0.5 \times CD \times h$ seen

B1 for forming the correct fraction and answer

(c) AG

3

$$\text{Area } YXZ = 0.5 \times XY \times XW \times \sin t$$

$$\text{Area } WXZ = 0.5 \times XZ \times XW \times \sin t$$

Divide to get the given answer by referring to part (b)

B1 for either $0.5 \times XY \times XW \times \sin t$,

Or $0.5 \times XZ \times XW \times \sin t$

B1 for the other one and divide.

B1 for a referral to part (b)

[7]

9. (a) 30.7 3

$$\tan x = \frac{1.9}{3.2}$$

$$x = \tan^{-1}\left(\frac{1.9}{3.2}\right) = 30.7$$

$$MI \text{ for } \tan x = \frac{1.9}{3.2} \text{ or } \tan \frac{1.9}{3.2}$$

$$MI \text{ for } \tan^{-1}\left(\frac{1.9}{3.2}\right)$$

$$AI \text{ for } 30.6 - 30.7$$

(b) 121 1

$$90 + "30.7"$$

BI (indep) ft for 90 + "30.7" rounded to 3 or 4 s.f

[4]

10. 53.8 3

$$\text{Area } \triangle ABC = \frac{1}{2} \times 14 \times 8 \times \sin 106 (= 53.8)$$

$$MI \text{ for } \frac{1}{2} \times 14 \times 8 \times \sin 106$$

$$MI \text{ (dep) for } 56 \times 0.961(26..) \text{ or } 107.6...$$

$$AI \text{ } 53.8 - 53.9$$

$$SC \text{ } 107.6 \text{ is } B2$$

[3]

11. (a) $\frac{29}{\sin 45^\circ} = \frac{18.4}{\sin \angle PEA}$ 3

$$\sin \angle PEA = \frac{18.4 \times \sin 45^\circ}{29} (= 0.4486...)$$

$$\angle PEA = 26.6569...$$

$$26.7$$

MI for correct substitution in sine rule

$$MI \text{ (dep) for rearrangement to get } \frac{18.4 \times \sin 45^\circ}{29} \text{ oe}$$

(award if 0.448(6...) or 0.538(8...) or 0.412(0...) seen)

AI cao for answers rounding to 26.7

(b) $\angle EPF = 2 \times [45 + '26.7'] (= 143.4)$

$$\text{arc } EF = \frac{143.4}{360} \times \pi \times 58$$

72.6

4

M1 for valid method to find $\angle EPF$ (award if $143(.4)^\circ$ seen)

M2 (dep) for $\frac{'143.4'}{360} \times \pi \times 58$

(M1 for either $\frac{'143.4'}{360} \times k_1$ or for $k_2 \times 58\pi$, where $k_2 < 1$)

A1 for 72.5 to 72.6 inclusive

SC award B2 for 61.1

[7]

12. (a) $\tan a = \frac{5}{6}$

3

Angle $a = 39.8^\circ$

39.8

M1 for $\tan(a =) \frac{5}{6}$

M1 for $a = \tan^{-1}(\frac{5}{6})$ or $\tan^{-1}(0.83)$ to $\tan^{-1}(0.834)$

(Allow $\tan^{-1} 5 \div 6$)

A1 for 39.8 – 39.81

SC 0.692 – 0.695 or 44.2 – 44.24 seen gets MIMI A0

(b) $\sin 40^\circ = \frac{x}{10}$

3

$$x = 10 \times \sin 40^\circ$$

6.43

M1 for $\sin 40 = \frac{x}{10}$

M1 for $10 \times \sin 40$

A1 for 6.427 – 6.43

(SC 7.45... or 5.87... seen gets MIMI A0)

[6]

13. $\frac{\sin ADB}{25} = \frac{\sin 28}{DB}$
 $DB = \frac{25 \times \sin 28}{\sin 26}$
 $DB = 26.77$
 $DC = 26.77 \times \sin 54$
 21.7

5

MI for $\frac{\sin "26"}{25} = \frac{\sin 28}{DB}$
MI for $DB = \frac{25 \times \sin 28}{\sin "26"}$
AI for 26.7 – 26.8
MI for $DC = "26.7" \times \sin 54$
AI for 21.65 – 21.7
 Or
MI for $\frac{\sin "26"}{25} = \frac{\sin "126"}{AD}$ oe
MI for $AD = \frac{25 \times \sin "126"}{\sin 26^\circ}$
AI for 46.1 – 46.2
MI for $"46.1" \times \sin 28^\circ$
AI for 21.65 – 21.7

[5]

14. (a) eg $\frac{4.2^2 + 5.3^2 - 7.6^2}{2 \times 4.2 \times 5.3}$
 $\frac{-12.03}{44.52}$ or $-0.2702\dots$
 105.7

3

MI for correct substitution into cosine rule to find any angle
MI(dep) for correct order of evaluation of their cosine rule to p
 get to $\cos X = \frac{p}{q}$ where p and q are numbers
 AI 105.67 – 105.7

(b) $\frac{1}{2} \times 4.2 \times 5.3 \times \sin 105.67^\circ$ 3
10.7

M2 for substitution of lengths of 2 sides and their included angle into $\frac{1}{2}ab \sin C$

(M1 if it is their angle but not the included one)

A1 for 10.7 – 10.72

[6]

15. $AB^2 = 8^2 + 9^2 - 2 \times 8 \times 9 \times \cos 40$

$$AB^2 = 64 + 81 - 144 \times \cos 40$$

$$AB^2 = 145 - 144 \times 0.766$$

$$AB^2 = 145 - 110.31... = 34.6896$$

$$AB = \sqrt{34.6796} = 5.8897877$$

$$5.89$$

3

M1 Subs in Cos Rule: $8^2 + 9^2 - 2 \times 8 \times 9 \times \cos 40$

M1 correct order of evaluation of $8^2 + 9^2 - 2 \times 8 \times 9 \times \cos 40$

A1 cao 5.88 – 5.89

SC: Award B2 for one of

$AB^2 = 241.03... \text{ or } AB = 15.525... \text{ (radians)}$

$AB^2 = 28.50... \text{ or } AB = 5.33... \text{ (gradians)}$

[3]

16. $\frac{1}{2} \times x^2 \times \sin 60 = 36$

$$x^2 = \frac{72}{\sin 60} = 83.13..$$

$$= 9.12$$

3

M1 $\frac{1}{2} \times x^2 \times \sin 60 (= 36)$ or $\frac{1}{2} \times ab \times \sin 60 (= 36)$

or $\frac{1}{2} \times x \times \sqrt{x^2 - \left(\frac{x}{2}\right)^2} (= 36)$

M1 $x^2 = \frac{72}{\sin 60}$ or $ab = \frac{72}{\sin 60}$ or $x^2 = \frac{36 \times 2}{\sqrt{0.75}}$

A1 9.11 – 9.12

[3]

$$17. \quad DC^2 = 5^2 + 8^2; DC = \sqrt{89}$$

$$DB^2 = 5^2 + 10^2; DB = \sqrt{125}$$

$$BC^2 = 8^2 + 10^2; BC = \sqrt{164}$$

$$\cos CDB = \frac{89 + 125 - 164}{2 \times \sqrt{89} \times \sqrt{125}} = 0.23702$$

$$= 76.3$$

6

$$M1 (DC^2 =) 5^2 + 8^2 \text{ or } DC = \sqrt{89} = 9.4(3)$$

$$M1 (DB^2 =) 5^2 + 10^2 \text{ or } DB = \sqrt{125} = 11.1(8)$$

$$M1 (BC^2) = 8^2 + 10^2 \text{ or } BC = \sqrt{164} = 12.8(1)$$

$$M2 \cos CDB = \frac{'89' + '125' - '164'}{2 \times \sqrt{'89'} \times \sqrt{'125'}}$$

$$A1 76.2 \times 76.3$$

or

M1 correct sub into cosine rule on formula sheet

$$\sqrt{'164'}^2 = \sqrt{'89'}^2 + \sqrt{'125'}^2 - 2 \times \sqrt{'89'} \times \sqrt{'125'} \times \cos x$$

$$M1 \text{ correct rearrangement to } \cos CDB = \frac{'89' + '125' - '164'}{2 \times \sqrt{'89'} \times \sqrt{'125'}}$$

$$A1 76.2 - 76.3$$

[6]

$$18. \quad \cos x = \frac{12^2 + 10^2 - 15^2}{2 \times 12 \times 10} = \frac{19}{240}$$

$$x = \cos^{-1} 0.079 = 85.459\dots$$

OR

$$15^2 = 12^2 + 10^2 - 2 \times 12 \times 10 \times \cos x$$

$$\cos x = \frac{15^2 - 12^2 - 10^2}{-2 \times 12 \times 10} = \frac{12^2 + 10^2 - 15^2}{2 \times 12 \times 10} = \frac{19}{240}$$

$$x = \cos^{-1} 0.079 = 85.459\dots$$

85.5

3

$$M2 \cos A = \frac{12^2 + 10^2 - 15^2}{2 \times 12 \times 10}$$

A1 85.4 -85.5

OR

M1 correct substitution into $a^2 = b^2 + c^2 - 2bc \cos A$ M1 correct rearrangement of $a^2 = b^2 + c^2 - 2bc \cos A$ algebraically to

$$(\cos A) = \frac{b^2 + c^2 - a^2}{2 \times b \times c} \text{ oe}$$

or to

$$(\cos A) = \frac{12^2 + 10^2 - 15^2}{2 \times 12 \times 10} \text{ oe}$$

These can be earned in either order

A1 85.4-85.5

SC B2 Radians 1.49 seen

B2 Gradians 94.89-95 seen

[3]

19. Let $DB = x$, then $AD = 3x$ And $AC = 2x$

$$BC = \sqrt{(4x)^2 + (2x)^2} = \sqrt{20}x$$

$$\sin C = 4x / \sqrt{20}x$$

$$\sin C = 4/\sqrt{20}$$

4

M1 for correct ratio of AC and AB [4x and 2x]

M1 for correct use of pythagoras

$$A1 \text{ for } BC = \sqrt{20}x$$

A1 for completion of proof

SC: B1 for $k = 4$

[4]

20. (a) 14.4 cm 3

$$(15^2 + 8 - 2 \cdot 15 \cdot 8 \cdot \cos 70)$$

M1 for correct subs in cos formula

M1 (dep) for correct order of evaluation

A1 for 14.4 or better

(b) 78.5° 2

$$\sin A = \frac{15 \sin 70}{14.4}$$

$$\cos A = \frac{14.4^2 + 8^2 - 15^2}{2 \times 8 \times 14.4}$$

$$\text{M1 for } \frac{15 \sin 70}{14.4} \text{ or } \frac{14.4^2 + 8^2 - 15^2}{2 \times 8 \times 14.4}$$

A1 for 78 < ans ≤ 78.6

[5]

21. 5.66... 3

$$6.2 \times \cos 24^\circ \\ = 6.2 \times 0.91\dots$$

$$\text{M1 for } \cos 24^\circ = \frac{BC}{6.2}$$

M1 for 6.2 × cos 24°

A1 for 5.66 or better

[3]

22. 30.7 3

$$\tan x = \frac{1.9}{3.2}$$

$$x = \tan^{-1}\left(\frac{1.9}{3.2}\right) = 30.7$$

$$\text{M1 for } \tan x = \frac{1.9}{3.2} \text{ or } \tan \frac{1.9}{3.2}$$

$$\text{M1 for } \tan^{-1}\left(\frac{1.9}{3.2}\right)$$

A1 for 30.6 – 30.7

[3]

23. BOC is a right angle triangle
Angle BOC = 62°

$$\cos 62 = \frac{7}{OB}$$

$$OB = \frac{7}{\cos 62}$$

14.91...

4

B1 for $\angle OCB = 90^\circ$ and one other correct angle in triangle OBC

$$\text{M1 for } \cos 62 = \frac{7}{OB} \text{ or } \sin 28 = \frac{7}{OB}$$

$$\text{M1 for } OB = \frac{7}{\cos 62} \text{ or } OB = \frac{7}{\sin 28}$$

A1 for 14.89 – 14.93

[4]

24. $\cos B = 2.3/5.4$
 $B = \cos^{-1}(2.3/5.4)$
 64.8°

3

M1 for $\cos B = 2.3/5.4$

M1 for $B = \cos^{-1}(2.3/5.4)$

A1 for an answer in the range 64.5 to 65.2

[3]

25. (a) $\frac{\sqrt{3.39\dots}}{1.985} = \frac{1.84\dots}{1.985}$
0.9287...

2

B2 for 0.9287(397....)

(B1 for sight of 3.39(....) or 1.84(....) or 1.985)

- (b) 0.93

1

B1ft (indep) for writing "0.9287..." correct to 2, 3 or 4 sig figs

[3]

$$26. \quad \sin 40^\circ = \frac{x}{10}$$

$$x = 10 \times \sin 40$$

$$6.43$$

$$M1 \text{ for } \sin 40 = \frac{x}{10}$$

$$M1 \text{ for } 10 \times \sin 40$$

$$A1 \text{ for } 6.427 - 6.43$$

[SC: 7.45.....or 5.87... seen gets MIMIAO]

[3]

$$27. \quad AB^2 = 7^2 + 10^2 - 2(7)(10) \cos 73^\circ$$

$$= 149 - 140(0.29237...)$$

$$= 108.0679...$$

$$10.4$$

M1 for correct substitution

M1 for correct order of operations (=108)

[SC : 15.87...or 9.55 ...seen gets MIMIAO]

A1 for 10.39 - 10.41

3

[3]

1. Paper 3

Correct notation in using trigonometry was frequently absent in this question. Calculator notation or other abbreviations inhibited many candidates from correctly quoting the full trigonometric formula. This sometimes led to confused or unclear working, which lost candidates marks. Premature approximation frequently spoiled interim working or the final answer. In part (a), a significant number of candidates were able to calculate the angle correctly. In part (b), candidates frequently associated the angle and side with Sine, but were unable to undertake the manipulation to arrive at the required calculation.

Paper 6

This was a harder trigonometric question as it involved two triangles. However, no value had to be transferred from one triangle to the next, so providing candidates recognised this, there should have been no major problems.

Part (a) assessed the use of \tan in triangle ABC . Candidates were able to spot this and then use the inverse to find the angle. Generally the correct trigonometric ratio was selected in part (b) and it was pleasing to see the many correct manipulations to find the length of the side BD . Some candidates took advantage of the formula sheet available on this tier and used the sine rule, sometimes in the biggest triangle. Generally they lost a mark because of premature rounding.

2. Candidates who had learned the basic trigonometric rules in a general triangle found this question straightforward. Most candidates applied the $\frac{1}{2}ab \sin C$ rule correctly and found the correct answer.

Furthermore, most candidates could use the cosine rule to find the length of AC . The main source of errors came from those who evaluated $a^2 + b^2 - 2bc \cos A$ as $(a^2 + b^2 - 2bc) \cos A$.

3. This question proved to be too difficult for the candidature. Most earned 1 mark for substitution into the equation. However, most could not make much progress beyond this as they failed to understand the meaning of $\sin 30(3 - k)$, often giving the answer $0.5(3 - k)$. One or two candidates realised the significance of the maximum and minimum value of sine to gain a second mark.

4. Mathematics A Paper 5

It is a pleasure to report that a majority of candidates graded above C gained at least some credit for correct answer(s) in parts (a) of this final question. As expected part (b) was a challenge to all but the top grade candidates. The examiners required the correct terminology for the transformations to be used (stretch) and also clear indications of the directions and scale factors.

Mathematics B Paper 18

Correct answers to part (a) were seen from approximately half of candidates although $y = \sin 2x$ was a common incorrect answer for the second graph. Few candidates were able to describe the transformations in (b) with the majority of the candidates describing the shape of the graph.

5. Paper 4

Candidates had a clear opportunity to demonstrate their understanding of Pythagoras' and Trigonometry in this question, and the majority did so, even the weaker candidates gaining some credit when method was shown. In part (a) most gained the full marks, though there were some who attempted $10^2 - 6^2$, or stopped at 136 (did they have a calculator without a square root key?). It was encouraging to find that most candidates realised that Cosine was needed in part (b), with greater success than in recent years. Many gained full marks, but a significant number could get no further than $\cos x = 0.8$. Some candidates gave a final answer which was very near to the correct answer, but no marks could be awarded when no working was seen in support of their answer; this could happen whenever a candidate performs the operation solely on a calculator, but incorrectly rounds their answer when writing it on the answer line.

Paper 6

Part (a) was a standard Pythagoras. Candidates did not appear to be put off by the juxtaposition of the two triangles and most obtained the correct answer.

Part (b) was not quite as well done, but competent candidates used (inverse) cosine to find the angle. A few candidates used the formula sheet and gave the sine rule to find angle E . They did not receive any credit until they had gone on to find the angle marked x .

6. Mathematics A Paper 6

This proved to be a somewhat challenging question, but it is pleasing to see how many candidates made inroads into this multistep problem. Successful candidates fell into two groups.

The first used $\text{area} = \frac{1}{2} ab \sin C$ to find the angle at B and then use the cosine rule to find the

length of the opposite side AC . The second used the rule $\text{area} = \frac{1}{2} bh$ to find the length of the

altitude AD . Two uses of Pythagoras in triangle ABD and ACB resulted in AC being found.

The two approaches seemed to be equally common. However, those who chose the trigonometrical approach often fell into one of two errors. The first one was to think that they had found the angle C , instead of angle B ; the second was to evaluate the cosine rule incorrectly.

Mathematics B Paper 19

A variety of different methods were seen. The most common approach was to use the sine rule to evaluate angle B then the cosine rule to evaluate AC . In this approach, the most common error came when evaluating AC by carrying out the arithmetic operations in the wrong order. The other method commonly seen was to work out BC (or AB) from using area of

triangle $= \frac{1}{2} \times \text{base} \times \text{height}$, then using Pythagoras's Theorem twice to obtain AC (or a

combination of trigonometry and Pythagoras's theorem). A very common error was for candidates to assume that triangle ABC was right-angled and attempt to use Pythagoras's theorem.

7. This is probably the question in which candidates lost most marks through not showing intermediate steps of working out. It is perhaps all too easy simply to attempt to plug the figures into a calculator, yet more than half the candidates gave just an incorrect answer on the answer line and lost all 3 marks. Clear evidence of correct substitution would have earned the first mark. Nearly all errors could be linked to incorrect processing of operations on the calculator.

8. Part (a) was a routine application of the area = $\frac{1}{2}ab \sin C$. Most candidates were able to do this.

Part (b) asked candidates to show that the ratio of areas of triangles with the same height is equal to the ratio of the bases. There was a clue in the question as the height was clearly indicated by h . The idea was to form the expression $\frac{1}{2}b_1h \div (\frac{1}{2}b_2h)$ and cancel the halves and the h s. Many candidates did this but a sizable minority could not get started. A few candidates tried to use $\frac{1}{2}AC \times BC \times \sin C$ in the two triangles and then cancelled the AC and then the C

failing to spot that the second expression for the area should have been $\frac{1}{2}AC \times BC \times \sin(180 - C)$. Of course the method will work because $\sin C$ and $\sin(180 - C)$ have the same value. Unless candidates clearly stated this fact they did not get full marks. A surprising number of candidates wrote that the triangles were similar.

On part (c), candidates had to write down two expressions for areas of triangles using $\frac{1}{2}ab \sin C$ where C is the value of the bisected angle and then use part (b) to get the required result. Few candidates were able to give the full logic required, but many were able to gain at least one mark. Many candidates did not help themselves by using poor notation especially when naming the two halves of the bisected angle.

9. Higher Tier

Weaker candidates always find trigonometry challenging. The first task was to use \tan and identify the sides correctly. The next step was to calculate $1.9 \div 3.2$ and then find the inverse tangent. Here many candidates came to grief because they wrote $\tan^{-1} \frac{1.9}{3.2}$ and found

$(\tan^{-1} 1.9) \div 3.2$.

Other candidates made use of the formulae at the front of the examination paper. They worked out the length of SP using Pythagoras, followed generally by the sine rule, almost invariably with $\sin x$ in the denominator. Some were able to complete the calculation and get full marks. Part (b) was poorly done as many candidates did not realise that a bearing was an angle measured clockwise from North.

Intermediate Tier

The majority of candidates made an attempt at answering this question despite it being near the end of the paper, but many did not recognise that they needed to use trigonometry. It was encouraging that most of those that did were able to identify the tangent of the angle as $1.9/3.2$. Some were unable to proceed any further and others made errors when finding $\tan^{-1}(1.9/3.2)$. It was not uncommon, for example, for $\tan^{-1}1.9 \div 3.2$ to be evaluated. Very few used their answer from part (a) when attempting to find the bearing in part (b). Those that did often subtracted the angle from 360 or added it to 180, instead of adding it to 90. Many candidates chose to measure the bearing on the diagram, despite the “Diagram NOT accurately drawn” warning.

10. Most candidates went straight to $\frac{1}{2}ab \sin C$ and scored full marks. A few candidates took the formula literally and tried to work out angle C or assumed the triangle was isosceles.
11. In part (a), about half the candidates recognised the need to use the sine formula, but a small minority attempted erroneously to use the tangent ratio. Only the best candidates were able to gain much credit in part (b). A significant number thought that the arc EF had centre A , and consequently used the cosine rule to find AE . Candidates should be encouraged to use all stated information and not make assumptions about diagrams. Some candidates attempted to calculate the length EF .

12. Intermediate Tier

Only the better candidates gave completely correct solutions to both parts of this question. Many did not recognise that they needed to use trigonometry and some did not attempt the question at all. In part (a) the majority of those using trigonometry identified the tangent of the angle as $5/6$. Some were unable to proceed any further. Others rounded the value of $5/6$ to 0.8 or 0.83 and lost the required accuracy in the final answer. In part (b) a common error was to use cosine. When sine was used candidates tended to be more successful than in part (a) although some truncated the answer to 6.42 and lost the final mark.

Higher Tier

In part (a), candidates generally used \tan correctly to find the angle a . Some candidates lost marks through premature approximation of the decimal equivalent of $\frac{5}{6}$. A few candidates tried to depend on the formula sheet and to calculate the hypotenuse followed by the cosine rule. A few also tried to use either sine or cosine in the triangle. In part (b), candidates were generally successful in using sine to find the length of the side.

13. Specification A

Many candidates recognised that they had to use the sine rule in triangle ABD to find the length of either AD or BD . The better candidates went on to use sine in either triangle ADC or triangle BDC as appropriate. Other candidates managed to gain nearly full marks by starting in the same way but then finding BC followed by Pythagoras or by using tan. Some candidates produced equations by using tan in triangle DBC and in triangle DAC to get $DC = x \tan 54^\circ$ and $DC = (x + 28) \tan 25^\circ$ followed by equating the two expressions for DC . Many weaker candidates assumed that right angled triangle trigonometry could be used in any of the triangles.

Specification B

A great variety of methods were seen in attempts to answer this question, many of them incorrect in various ways. The most efficient method of solution was to apply the sine rule once and then use a trigonometric ratio. A fully correct solution was seen from approximately 25% of candidates. Of the candidates that gained full marks some used the most efficient method of solution while more used the sine rule twice, then a trigonometric ratio or the sine rule followed by the cosine rule then a trigonometric ratio. The majority of candidates were able to gain the final method mark for a correct use of a trigonometric ratio in triangle BDC .

- 14.** This proved to be a challenge for all but the better students. Firstly, the task required the use of the cosine rule in the form which is not on the formula page. Secondly, candidates had to realise that the biggest angle was opposite the longest side, or otherwise were in for a lot of additional work. Some who did it this way started with the cosine rule and found correctly one of the other angles. They went on to use the Sine Rule to find the other angle and most inevitably gave the (incorrect) acute angle answer of 74.3 . Many candidates were not up to the manipulation of the cosine formula either algebraically or by transforming the substituted expression. The usual error of $b^2 + c^2 - 2bc \cos A$ between misinterpreted as $(b^2 + c^2 - 2bc) \cos A$ was frequently seen. Part (b) was more successfully answered, with most candidates realising that $\frac{1}{2} ab \sin C$ had to be used. In addition, there were several candidates who used Hero's formula correctly to find the area.
- 15.** This was a standard cosine rule question. Responses tended to fall into 3 categories: firstly those who used the cosine rule correctly, secondly, those that used the cosine rule incorrectly and thirdly those that did not use the cosine rule at all. The main misuse of the cosine rule occurred at the stage $145 - 144 \cos 40^\circ \Rightarrow \cos 40^\circ$ with an answer which is a decimal. This is another BIDMAS error of a similar type to that which occurred in Question 17e. The third category tended to assume that either the triangle was isosceles or that right angled trigonometry could be used.

16. Good candidates wrote down $\frac{1}{2}ab \sin 60$ as their first step and then applied this idea to get an equation in x . Good candidates went on to write equations like $x^2 = \frac{72}{\sin 60^\circ}$ and then find 9.12 for the value of x . A few candidates lost their marks by writing $2x$ for x^2 or by dividing 36 by 2 instead of multiplying by 2. Candidates who tried to use base \times height $\div 2$ were generally unsuccessful as they could not get the correct algebraic expression for the height, generally writing $\sqrt{x^2 - \frac{1}{2}x^2}$.
17. Although as a whole this was a challenging question to finish off the paper, many candidates recognised that they had to find the 3 sides of the triangle. This many of them succeeded in doing by employing Pythagoras 3 times. (Unfortunately, many found BC to be 6 cm). The next stage was much more difficult. Many assumed that the median of triangle CDB was also perpendicular to the base and thus lost all the remaining marks. Others tried to use the cosine rule from the formula page but were unable to perform the correct algebraic manipulations to isolate the cosine. Candidates who had taken the trouble to learn the cosine rule in this form who generally more successful.
18. Candidates who had put in some preparation were rewarded on this question by a task which involved a straight substitution and it was very telling that this approach yielded much more success than that of using the given formula at the front of the paper and then manipulating to isolate $\cos A$. Of the candidates who did adopt this latter approach, many forgot about operator precedence and ended up with $225 = 4 \cos A$ from which they concluded that A was 56.25 degrees.
19. Very few correct answers were seen. A minority of candidates gained marks for the correct ratio of sides AB and AC . The idea of a proof seemed beyond the vast majority of candidates. Those who did attempt the question generally tried to find the size of angle C .
20. Candidates frequently treated the given triangle as a right angled and then incorrectly used trigonometry and/or Pythagoras's Theorem throughout. Of those candidates who recognised that the question was most efficiently solved in (a) by using the cosine rule a disappointingly large number then carried out the calculation in the wrong order frequently writing $289 - 240\cos 70$ as $49\cos 70$. In part (b) candidates frequently had problems in rearranging the sine rule correctly so that $\sin BAC$ was the subject.

21. Only a minority (20%) correctly used the cosine of the angle in attempting to solve this problem. Of these the majority (16%) went on to accurately calculate the required length. The others who recognised the need to use trigonometry usually used $\tan 24^\circ$; however the greater number showed little idea at all, often guessing or drawing scale diagrams.
22. Again the understanding of, and the ability to use trigonometry, was not good. Pythagoras was tried by some and scale diagrams by others. When trigonometric methods were attempted the setting out of the solutions left much to be desired with poor notation; $\tan\left(\frac{1.9}{3.2}\right)$, $\left(\frac{1.9}{3.2}\right)\tan$, $\tan 1.9 \div 3.2$ were common statements made, and only subsequent working convinced the reader of the understanding of the candidate.
 $\tan^{-1} \frac{1.9}{3.2}$ was often interpreted as $(\tan^{-1} 1.9) \div 3.2$ resulting in error.
23. Over half of all candidates gained a mark by identifying the right angle and working out one other angle in triangle OBC . After this, success was varied. Those candidates who recognised that OC was a radius of the circle and therefore of length 7cm were generally able to go and find a correct solution. A disappointingly large number of candidates failed to recognise that OC was of length 7cm and tried to incorrectly use trigonometry in triangle OAC to evaluate the length of OC . Fully correct solutions to this question were given by approximately 12% of candidates.
24. use of trigonometry was poor; very few even attempted trigonometric methods, preferring instead Pythagoras to calculate the length of the third side. Of those who did use trigonometry few went beyond $\cos? = \frac{2.3}{5.4}$.
25. In part (a) the correct answer was seen from only approximately 60% of candidates. Of those who failed to gain the correct answer some, but not all candidates, were able to gain a method mark for demonstrating that at least part of the calculation had been carried out with due regard for the correct order of operations. A number of candidates showed no interim working so, when their final answer was wrong, were unable to pick up the available method mark. A common incorrect answer was 1.2285... which occurs when the square root of just 2.56 and not the complete numerator is taken. The majority of candidates were able to round their answer to part (a) correctly to gain a mark in part (b).

26. Many fully correct solutions were seen. In some cases candidates did not round their final answer correctly and did not show their uncorrected answer. In such circumstances, the final accuracy mark was lost. The majority of candidates use the trigonometric ratio for sine, a number of candidates successfully used the sine rule. The common incorrect method was to use cosine.
27. The relevant values were frequently substituted correctly into the cosine rule. This was then frequently simplified incorrectly to $9\cos 73^\circ$ rather than left as $149 - 140\cos 73^\circ$. A few candidates forgot to take the square root and so lost the final accuracy mark. The most common error was to use Pythagoras's theorem even though the triangle was clearly not right angled.