

Q1.

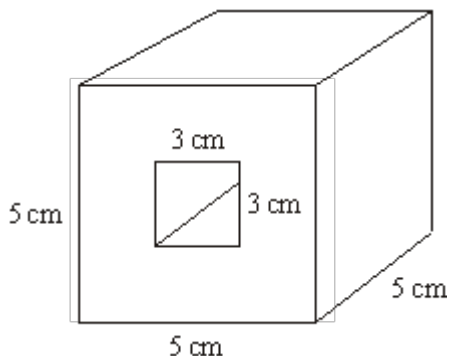

Diagram **NOT** accurately drawn

The solid shape, shown in the diagram, is made by cutting a hole all the way through a wooden cube.

The cube has edges of length 5 cm.

The hole has a square cross section of side 3 cm.

(a) Work out the volume of wood in the solid shape.

..... cm<sup>3</sup>

(2)

The mass of the solid shape is 64 grams.

(b) Work out the density of the wood.

..... grams per cm<sup>3</sup>

(2)

(Total 4 marks)

**Q2.** A water trough is in the shape of a prism.

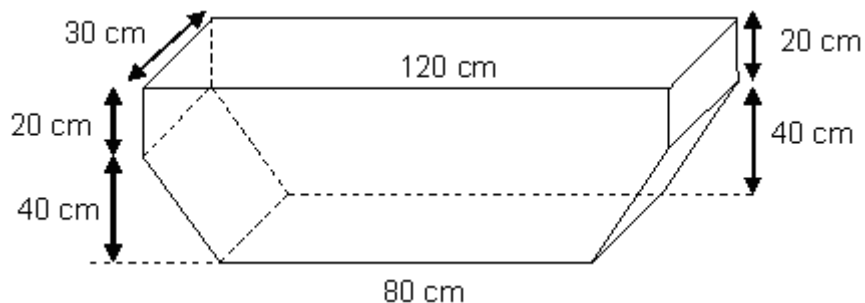

Diagram **NOT** accurately drawn

Hamish fills the trough completely.

Water leaks from the bottom of the trough at a constant rate.  
2 hours later, the level of the water has fallen by 20 cm.

Water continues to leak from the trough at the same rate.

How many more minutes will it take for the trough to empty completely?

..... minutes

**(Total 6 marks)**

Q3.

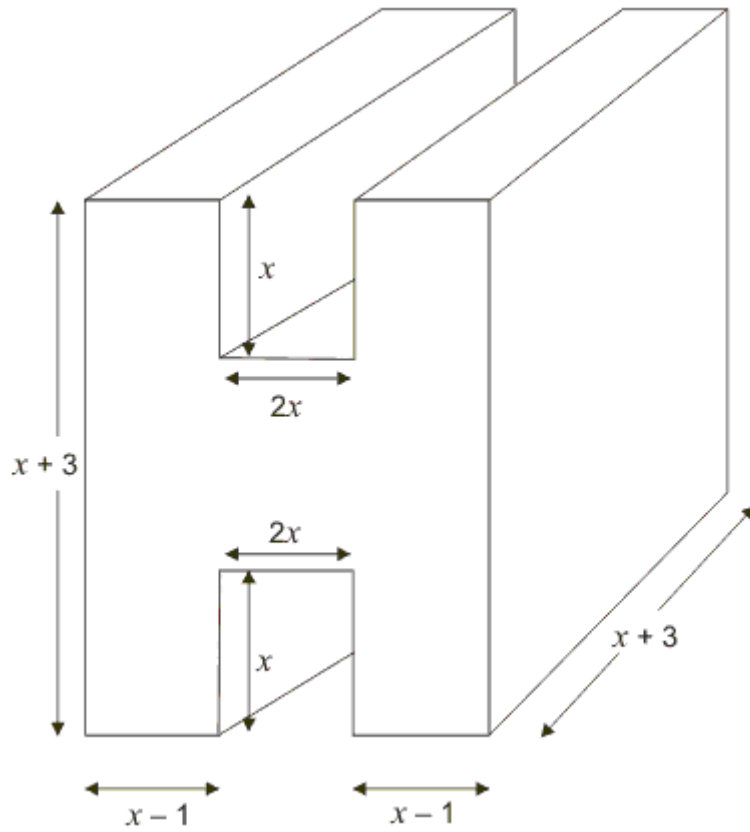
Diagram **NOT** accurately drawn

The diagram shows a prism.  
 All measurements are in cm.  
 All corners are right angles.  
 The volume of the prism is  $V \text{ cm}^3$ .

Find a formula for  $V$ .

$$V = \dots\dots\dots$$

(Total 4 marks)

Q4.

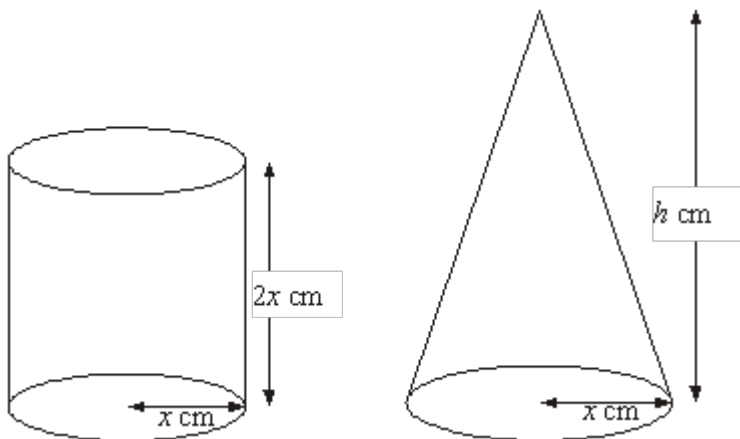

Diagram **NOT** accurately drawn

A cylinder has base radius  $x$  cm and height  $2x$  cm.

A cone has base radius  $x$  cm and height  $h$  cm.

The volume of the cylinder and the volume of the cone are equal.

Find  $h$  in terms of  $x$ .  
Give your answer in its simplest form.

$h = \dots\dots\dots$

(Total 3 marks)

**Q5.** The diagram shows a storage tank.

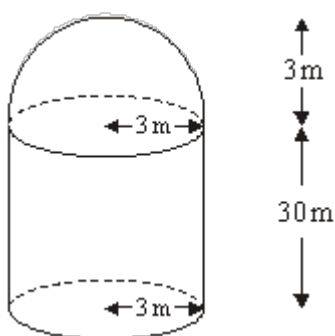

Diagram **NOT** accurately drawn

The storage tank consists of a hemisphere on top of a cylinder.

The height of the cylinder is 30 metres.

The radius of the cylinder is 3 metres.

The radius of the hemisphere is 3 metres.

- (a) Calculate the total volume of the storage tank.  
Give your answer correct to 3 significant figures.

$\dots\dots\dots \text{m}^3$

(3)

A sphere has a volume of  $500 \text{ m}^3$ .

- (b) Calculate the radius of the sphere.  
Give your answer correct to 3 significant figures.

..... m

(3)  
(Total 6 marks)

**Q6.** The graph can be used to convert between gallons and litres.

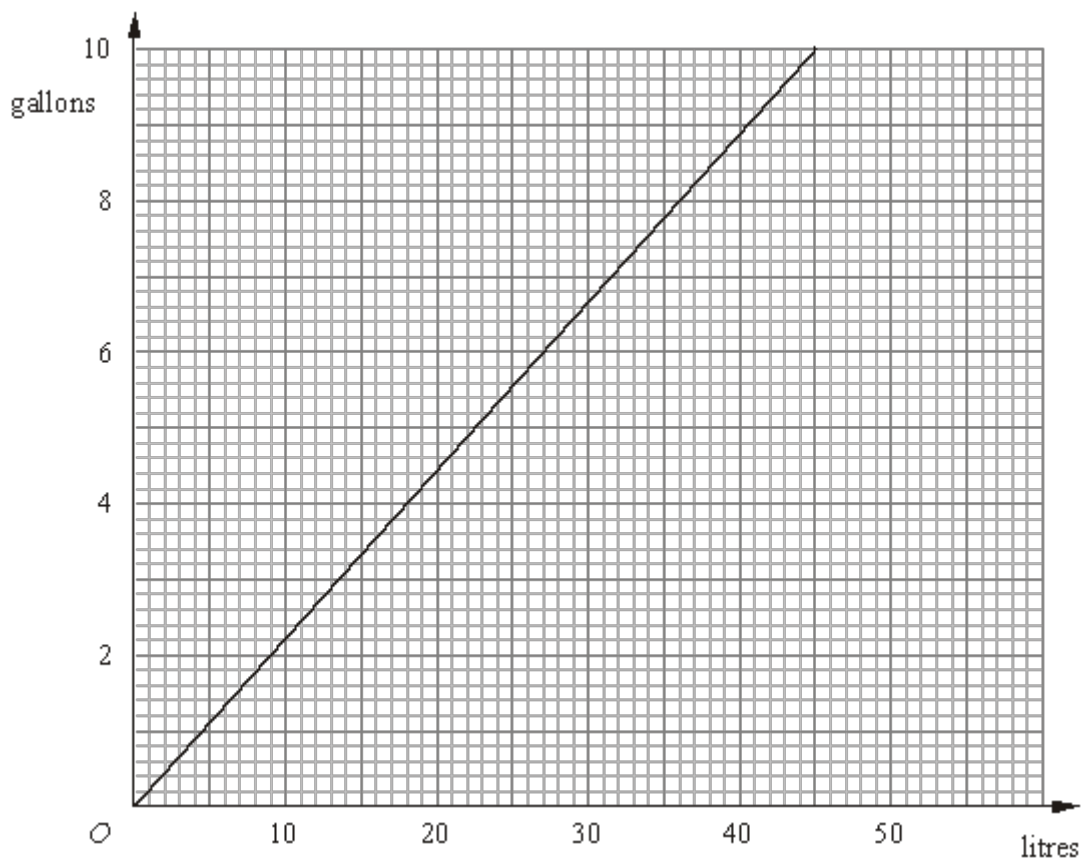

The diagram shows a central heating oil tank.



The oil tank is in the shape of a cylinder of length 180 cm and radius 60 cm.

The oil tank contains 200 gallons of oil.

- (a) Is the oil tank more or less than  $\frac{1}{2}$  full?

.....

(5)

The oil has a density of  $0.85 \text{ g/cm}^3$ .

(b) Work out, in kg, the mass of the oil in the tank.

..... kg

(3)  
(Total 8 marks)



M1.

	Working	Answer	Mark	Additional Guidance
(a)	$5^3 - 5 \times 3 \times 3$ $125 - 45$  $(5 \times 5 - 3 \times 3) \times 5$ $(25 - 9) \times 5$ $16 \times 5$	80	2	<b>M1</b> for attempt to find volume of cube (e.g. $5 \times 5 \times n$ where $n \neq 6$ ) and subtract volume of the hole (e.g. $3 \times 3 \times n$ where $n \neq 6$ ) (needs to be dimensionally correct) <b>A1</b> cao <b>Alternative method</b> <b>M1</b> for attempt to find area of the cross section and multiply by the depth of the prism (depth $\neq 6$ ) <b>A1</b> cao
(b)	$64 \div 80$	0.8	2	<b>M1</b> ft $64 \div "80"$ <b>A1</b> ft (to 2 sf or better)
<b>Total for Question: 4 marks</b>				

M2.

Working	Answer	Mark	Additional Guidance
45	200 minutes	6	<b>M1</b> for $120 \times 20 \times 30 (= 7200)$ <b>M1</b> for $"72000" \div 120$ <b>A1</b> for 600 cm <sup>3</sup> min oe  $\frac{1}{2} \times (120 + 80) \times 40 \times 30 (= 120000)$ <b>M1</b> for $\frac{1}{2} \times (120 + 80) \times 40 \times 30 (= 120000)$ <b>M1</b> for $"120000" \div "600"$ <b>A1</b> for 200 minutes or 3 hours 20 mins oe  SC B1 for 4 hours

Total for Question: 6 marks

M3.

Working	Answer	Mark	Additional Guidance
<p>Unknown length = <math>x + 3 - x - x = 3 - x</math></p> <p><b>Cross-sectional area</b>  <math>= (x + 3)(x - 1) + (x + 3)(x - 1) + (3 - x)(2x)</math>  <math>= x^2 + 2x - 3 + x^2 + 2x - 3 + 6x - 2x^2</math>  <math>= 4x - 6 + 6x</math>  <math>= 10x - 6</math></p> <p><b>Volume</b>  <math>= (10x - 6)(x + 3)</math>  <math>= 10x^2 + 24x - 18</math></p> <p><b>OR</b>  Unknown length = <math>x + 3 - x - x = 3 - x</math></p> <p><b>Volume</b>  <math>= (x + 3)(x + 3)(x - 1) + (x + 3)(x + 3)(x - 1) + (2x)(3 - x)(x + 3)</math>  <math>= (10x - 6)(x + 3)</math>  <math>= 10x^2 + 24x - 18</math></p> <p><b>OR</b>  Unknown length = <math>(2x - 2) + 2x = 4x - 2</math></p> <p><b>Surrounding area</b>  <math>= (4x - 2)(x + 3) = 4x^2 + 10x - 6</math>  So A = <math>4x^2 + 10x - 6 - 4x^2 = 10x - 6</math></p> <p>So V = <math>(10x - 6)(x + 3) = 10x^2 + 24x - 18</math></p> <p><b>OR</b>  Unknown length = <math>(2x - 2) + 2x = 4x - 2</math></p>	$10x^2 + 24x - 18$	4	<p><b>B1</b> for <math>x + 3 - x - x</math> oe or <math>3 - x</math> seen  or <math>x - 1 + 2x + x - 1</math> oe or <math>4x - 2</math> seen</p> <p><b>M1</b> for correct expression for 1 area from cross-section or for 1 volume of cuboid(s)  (brackets not needed)</p> <p><b>M1</b> for correct method for total cross-sectional area  OR at least 2 volumes added  OR volume of surrounding cuboid – at least 1 vol  (brackets needed)</p> <p><b>A1</b> for <math>10x^2 + 24x - 18</math> oe</p>

<b>Surrounding volume</b> $= (4x - 2)(x + 3)(x + 3)$ $V = (4x - 2)(x + 3)(x + 3) -$ $2x(2x)(x + 3)$			
<b>Total for Question: 4 marks</b>			

**M4.**

Working	Answer	Mark	Additional Guidance
$\pi x^2(2x) = \frac{1}{3} \pi(x)^2 h$	6x	3	<b>M1</b> for a correct volume formula in terms of $x$ , e.g. $\pi x^2(2x)$ or $\frac{1}{3} \pi x^2 h$ <b>A1</b> for $\pi(2x) = \frac{1}{3} \pi h$ or $3\pi x^2(2x) = \pi x^2 h$ or $x^2(2x) = \frac{1}{3} x^2 h$ (or better) <b>A1</b> for 6x cao
<b>Total for Question: 3 marks</b>			

**M5.**

	Working	Answer	Mark	Additional Guidance
(a)	$V_c = \pi \times 3^2 \times 30$ $V_k = \frac{2}{3} \times \pi \times 3^3$	905	3	<b>M1</b> $V_c = \pi \times 3^2 \times 30$ (= 848.2...) <b>or</b> $V_k = \frac{2}{3} \times \pi \times 3^3$ (= 56.54...)

	$V_c + V_k = 288\pi$			<b>M1</b> (dep) $V_c + V_k$ (may be implied) <b>A1</b> 904 – 905 inclusive
(b)	$\frac{4}{3} \times \pi \times R^3 = 500$  $R^3 = \frac{500 \times 3}{4 \times \pi}$	4.92	3	$\frac{4}{3} \times \pi \times R^3 = 500$ <b>M1</b> for  <b>M1</b> for correct process to reach $R^3 = \frac{500 \times 3}{4 \times \pi}$ oe (= 119.3...) or $\sqrt[3]{\frac{500 \times 3}{4 \times \pi}}$ (implies 1 <sup>st</sup> <b>M1</b> )  <b>A1</b> 4.915-4.925
<b>Total for Question: 6 marks</b>				

**M6.**

		Working	Answer	Mark	Additional Guidance
<b>FE</b>	(a)	1 gallon = 4.54 litres, 200 gallons = 908 litres = 908000 cm <sup>3</sup> Vol of tank $60^2 \times \pi \times 180 =$ 2035752.04..cm <sup>3</sup>  908000 < 1017876.02  <b>OR</b> Vol of tank $60^2 \times \pi \times 180 =$ 2035752.04..cm <sup>3</sup> Half vol of tank = 1017876.02 cm <sup>3</sup> = 1017.876...litres  1017.876 ÷ 4.54 = 224 gallons  224 > 200	No	5	Response may convert into gallons, litres, or cm <sup>3</sup>  Calculations may be performed in different orders  <b>M1</b> Using formulae to find volume of tank  <b>B1</b> Converts between litres and cubic centimetres  <b>M1</b> reads off graph for 1l, 2l, 4l, 5l or 10 litres within tolerance (4.4 – 4.6)  <b>A1</b> Answer in cm <sup>3</sup> , litres or gallons  <b>C1</b> Decision and reason <b>QWC:</b> <b>Decision should be stated, with appropriate supporting statement</b>

	(b)	$908000 \text{ cm}^3 \times 0.85 \text{ g/cm}^3$ $= 771800 \text{ g}$	771.8	3	<b>M1</b> $908000 \times 0.85$ <b>M1(dep)</b> $771800 \div 1000$ <b>A1</b> 770 – 772
<b>Total for Question: 8 marks</b>					

**E1.** Fully correct answers to this question were only given by 23% of candidates. In part (a) it was common to see the volume of the 5cm cube being given correctly but then incorrect calculations for the hole were frequently seen. Some candidates thought the hole was a 3 cm cube and not a square prism with length 5cm. Where candidates tried to subtract two sensible volumes they were awarded a mark, however it was quite common to see candidates try to subtract  $9\text{cm}^2$  away from  $125\text{cm}^3$  and therefore achieve no marks.

In part (b) full marks were awarded for dividing the mass of 64 grams by the volume calculated in part (a) and 39% of candidates scored 2 marks usually for doing this. A large number of candidates divided volume by mass or multiplied mass and volume and so gained no credit. It was disappointing to see 39% of candidates gaining no marks at all in this question.

##

The most successful candidates structured their working clearly, often annotating the diagram to show different sections to match their calculations. Some identified that as the trough was a prism, it was not essential to consider volume but worked with the cross-section areas instead. Large numbers with zeros led to many arithmetical errors and many candidates did not recognise that they had to consider the rate of leakage. These errors along with problems converting between minutes and hours meant that many candidates presented final answers which were far too large. Candidates need to be encouraged to make use of estimation and consider the reasonableness of any answer reached. Perhaps most importantly, candidates need to practice solving unstructured problems and compare the efficiency of a variety of approaches so that they can select appropriate methods to use.

##

This was another question that required organisation as well as basic algebraic skills. There were many instances of addition and multiplication being confused and brackets being omitted leading to incorrect expansions. The majority of candidates attempted this question, with varying degrees of success. Over 38% of candidates were able to score at least 1 mark and often 2 marks. These 1 or 2 marks were generally awarded for finding at least one correct expression for a cross-sectional area or for a volume (brackets could be ignored) and/or for finding a correct expression for the total width of the shape or the height of the middle of the H.

Those who had a correct strategy for calculating the volumes were let down by their algebraic skills. Brackets were often missing when they were essential. It was rare to see a complete method leading to a correct formula. Methods chosen were varied from working out the cross section by dividing it into separate areas or working out the surrounding area and subtracting the "missing bits". Working with the area seemed to be preferred to working out volumes.

- E4.** Many candidates were able to score one mark for writing a correct formula for the volume of the cone or the volume of the cylinder in terms of  $x$ , and some were able to equate two correct formulae, but few could rearrange the equation accurately to find  $h$

$$\frac{2x}{\left(\frac{1}{3}\right)} = \frac{2}{3}x$$

in terms of  $x$ . A common error here was  $\left(\frac{1}{3}\right)$ . A small number of candidates were able to compare the two volume formulae and simply write down the answer without working.

- E5.** In part (a), for the volume of the cylinder many used the diameter instead of the radius, others used the surface area. For the volume of the hemisphere – many did not divide by 2, others used  $4 \times \pi \times r^2$  and then divided by 2. Most candidates realised they had to add two answers together. Other errors in accuracy were through premature rounding. Just under 60% of candidates failed to gain any marks, about 16% of candidates gained full marks. In part (b) working was not always clear in this question and premature (or incorrect) rounding of values in responses where the working was sparse often cost candidates method marks that they might otherwise have gained.

Of those who made a reasonable attempt, many used  $\frac{4}{3} \pi r^2$  as their initial formula. Others got as far as  $R^3 = 119.3$  but then took the square root instead of cube root. Those candidates that started by quoting an equation were the most successful. The correct answer was seen from just over 14% of candidates.