

GCSE (9–1) Mathematics
J560/02 Paper 2 (Foundation Tier)

Thursday 8 November 2018 – Morning
Time allowed: 1 hour 30 minutes



You may use:

- geometrical instruments
- tracing paper

Do not use:

- a calculator



First name											
Last name											
Centre number						Candidate number					

INSTRUCTIONS

- Use black ink. You may use an HB pencil for graphs and diagrams.
- Complete the boxes above with your name, centre number and candidate number.
- Answer **all** the questions.
- Read each question carefully before you start to write your answer.
- Where appropriate, your answers should be supported with working. Marks may be given for a correct method even if the answer is incorrect.
- Write your answer to each question in the space provided. If additional space is required, use the lined page(s) at the end of this booklet. The question number(s) must be clearly shown.
- Do **not** write in the barcodes.

INFORMATION

- The total mark for this paper is **100**.
- The marks for each question are shown in brackets [].
- This document consists of **20** pages.

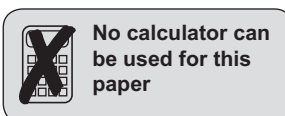

2

Answer **all** the questions.

1 Here is a hexagon.

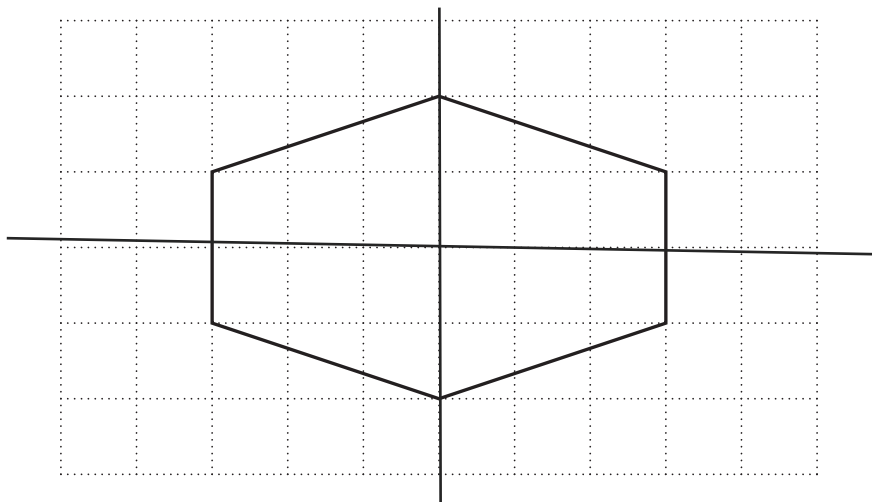

(a) On the diagram, draw the hexagon's two lines of symmetry. [1]

(b) Write down the order of rotation symmetry of the hexagon.

(b) 2 [1]

2 Work out.

(a) $\frac{1}{2}$ of 12

$$12 \div 2 =$$

(a) 6 [2]

(b) $8 \times \frac{1}{5}$

Give your answer as a mixed number.

$$8 \times \frac{1}{5} = \frac{8}{5} = 1\frac{3}{5}$$

(b) $1\frac{3}{5}$ [2]

(c) Isaac and Maya eat part of a pizza.

Isaac eats $\frac{1}{6}$ of the pizza.

Maya then eats $\frac{3}{5}$ of the remaining pizza.

What fraction of the original pizza is left?

$$1 - \frac{1}{6} = \frac{5}{6}$$

Maya eats $\frac{3}{5}$ of the $\frac{5}{6}$ $\frac{3}{5}$ of $\frac{5}{6} = \frac{3}{6}$ - maya eats

$$1 - \frac{1}{6} - \frac{3}{6} = \frac{2}{6} = \frac{1}{3}$$

(c) $\frac{1}{3}$ [4]

4

3 (a) Complete the statement using a term from the list.

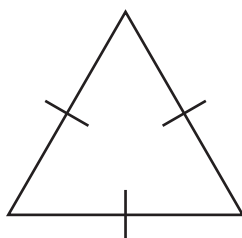

isosceles equilateral right-angled scalene

The triangle is equilateral (all sides are = in length) [1]

(b) These are the names of some special quadrilaterals.

rectangle parallelogram
trapezium kite rhombus

Choose a quadrilateral from the list that satisfies each set of conditions.

- (i) • All four sides are the same length.
• Opposite angles are equal.

(b)(i) Rhombus [1]

- (ii) • All four angles are right angles.
• Opposite sides are equal.

(ii) Rectangle [1]

(c) This is a square based pyramid.

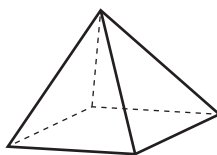

Complete the following.

A square based pyramid has 5 faces and 8 edges. [2]

4 These are the heights, in metres, of the players in a netball team.

1.30 1.13 1.20 1.23 1.22 1.24 1.15

(a) (i) Find the median height of the 7 players.

1.13, 1.15, 1.20, 1.22, 1.23, 1.24, 1.30

(a)(i) 1.22 m [2]

(ii) Work out the range of the heights of the 7 players.

biggest - smallest
 $1.30 - 1.13 =$

(ii) 0.17 m [2]

(iii) The sum of the heights of the 7 players is 8.47 m.

Calculate the mean height of the 7 players.

$$\text{Mean} = \frac{\text{Total sum}}{\text{Freq}}$$

$$= \frac{8.47}{7} =$$

$$\begin{array}{r} 1.21 \\ 7 \overline{) 8.47} \end{array}$$

(iii) 1.21 m [2]

(b) The tallest player is replaced by a substitute.

The median height of the players is unchanged.

The mean height of the players becomes smaller

less than the biggest number
 but more than median

Write down a possible height for the substitute.

(b) 1.29 m [2]

5 This graph shows the cost of buying potatoes from a farm.

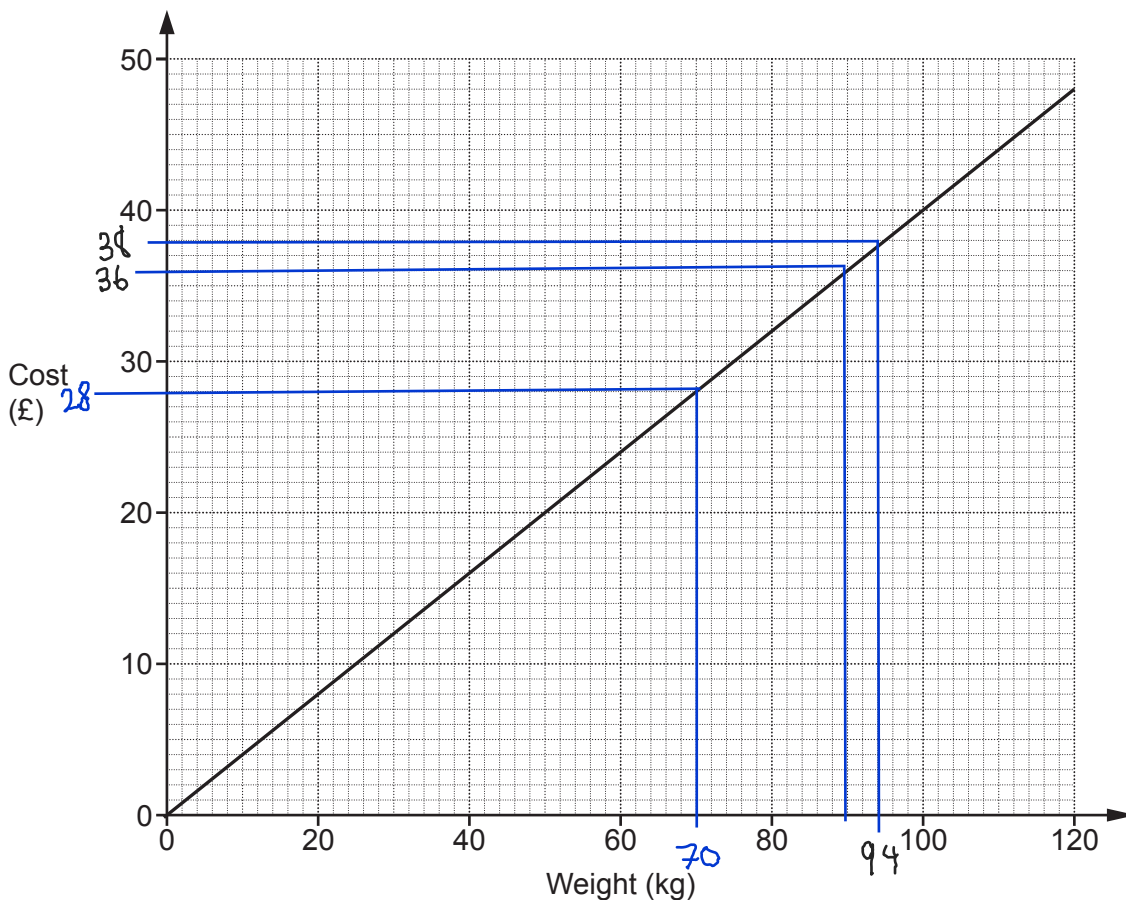

(a) (i) How much does it cost to buy 70 kg of potatoes?

(a)(i) £ 28 [1]

(ii) What weight of potatoes can be bought for £38?

(ii) 94 kg [1]

(iii) The cost per kilogram of potatoes is the same for any weight of potatoes.

How much will it cost to buy 180 kg of potatoes from the farm?

To buy 90kg = £36
 ↓ × 2 ↓
 180kg = £72

(iii) £ 72 [3]

(b) This graph shows the annual profits, in thousands of pounds, of the farm between 2013 and 2017.

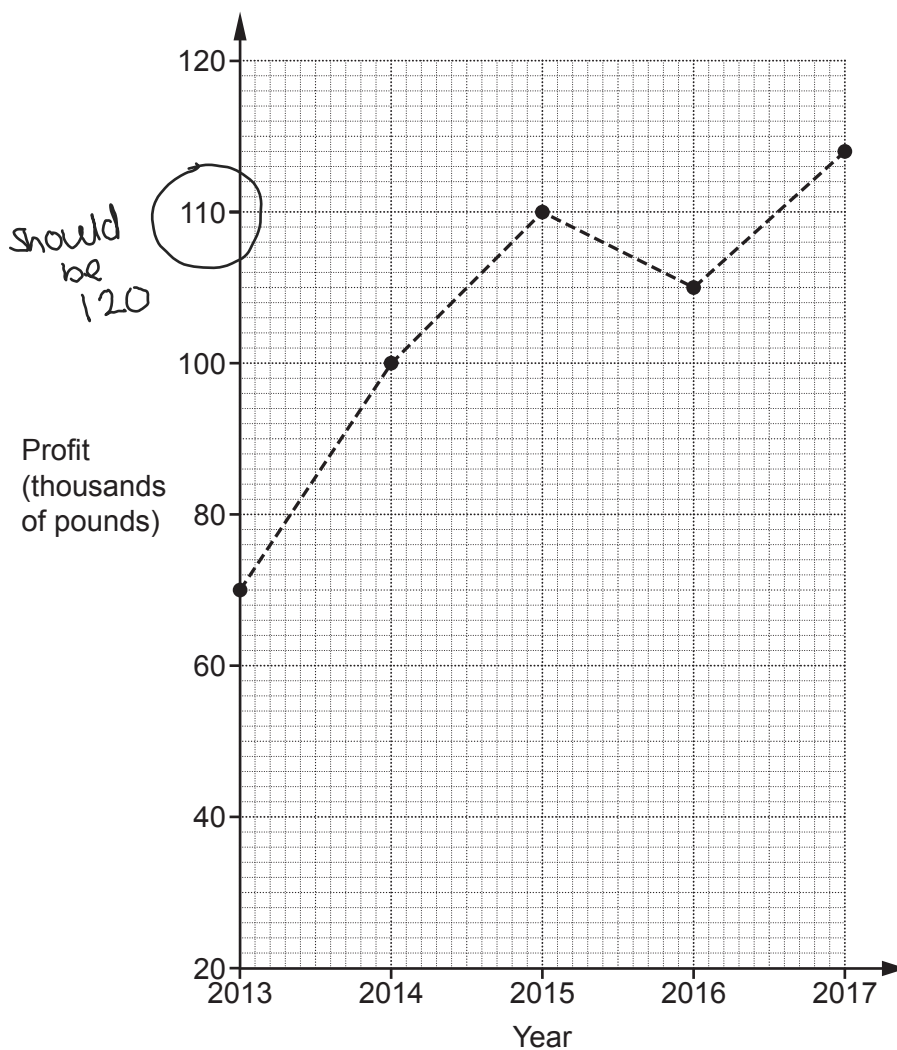

Describe one misleading feature of the graph.

..... The vertical scale is not linear [1]

6 Which is bigger, 36% or $\frac{7}{20}$?

Show your working and give a reason for your answer.

$$\frac{7}{20} \xrightarrow[\times 5]{\times 5} \frac{35}{100} \xrightarrow{\times 100} = 35\%$$

..... 36% is bigger because $\frac{7}{20} = 35\%$, which is
 less than 36%..... [4]

7 (a) Write down the value of $\sqrt[3]{27}$.

(a) 3 [1]

(b) Work out 7^2 .

$$7 \times 7$$

(b) 49 [2]

(c) Write 6^{-1} as a fraction.

neg power = $\frac{1}{6^1}$

(c) $\frac{1}{6}$ [1]

9

- 8 A water company charged the following in 2017.

£2.00 for each m^3 of water used
plus
a fixed charge of £45

In 2017 Jenny used 110m^3 of water.

For the 12 months of 2017 she paid £20 per month to the water company.

How much more money does Jenny need to pay to the water company?

Jenny paid $20 \times 12 =$ £240 in 2017

Jenny needs to pay: $\text{£}2 \times 110 + 45$
 $= 220 + 45 = \text{£}265$

$$265 - 240 =$$

£ 25 [6]

- 9 (a) Rearrange this formula to make x the subject.

$$y = x - 2$$

+2

(a) $x = y + 2$ [1]

- (b) Rearrange this formula to make d the subject.

$$C = \pi d$$

$\div \pi$

(b) $d = \frac{C}{\pi}$ [1]

10

10 (a) Write down the equation of each of these lines.

(i)

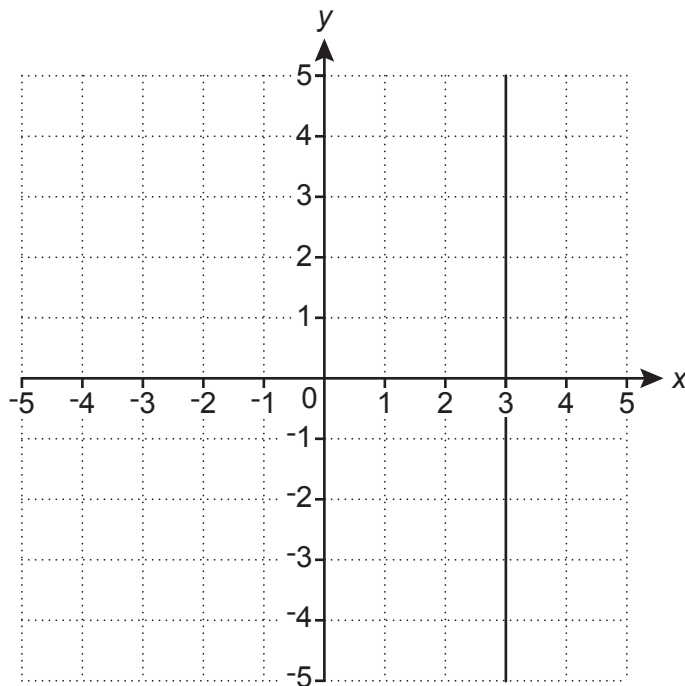

all x values are 3.

(a)(i) $x = 3$ [1]

(ii)

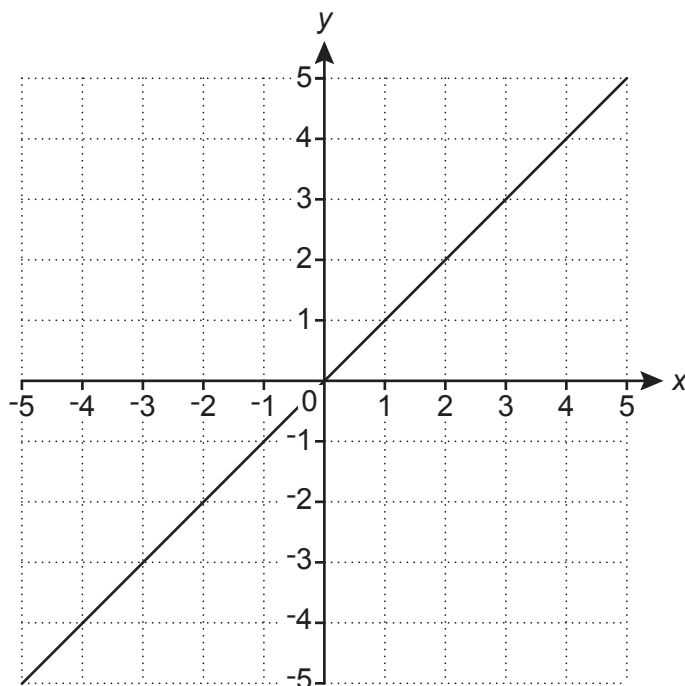

(ii) $y = x$ [1]

(b) Sketch the graph of $y = x^2$.

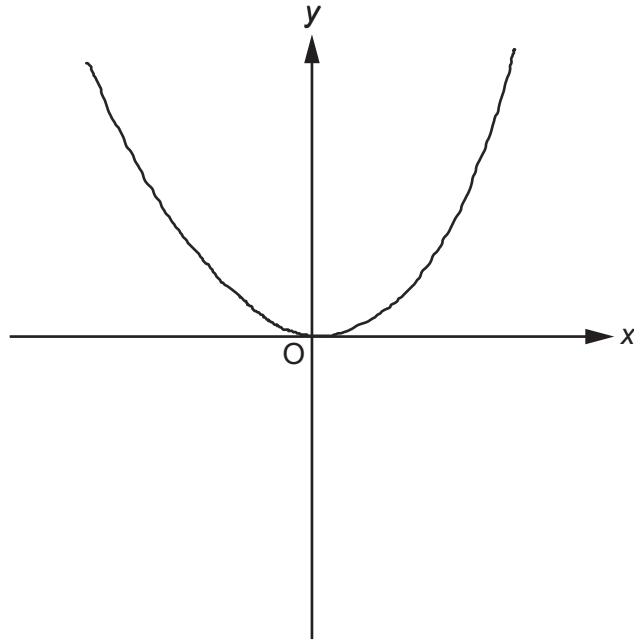

[1]

11 Some biscuits contain only three ingredients: flour, butter and sugar.

- The ratio of flour to butter is 5 : 4.
- The ratio of butter to sugar is 2 : 1.
- The total weight of the flour, butter and sugar is 770g.

Work out the weight of each of the ingredients.

$$\begin{array}{l}
 F : B \qquad \qquad B : S \\
 5 : 4 \qquad \qquad 2 : 1 \quad \times 2 \\
 \qquad \qquad \qquad 4 : 2
 \end{array}$$

F : B : S	Total	
5 : 4 : 2	11	
$\xrightarrow{\times 70}$ 350 : 280 : 140	$\xleftarrow{\times 70}$ 770	
		Flour 350 g
		Butter 280 g
		Sugar 140 g [4]

12 (a) Work out.

$$\begin{array}{l}
 8 \div 0.4 \\
 \times 10 \qquad \times 10 \\
 \hline
 80 \div 4 =
 \end{array}$$

(a) 20 [2]

(b) By writing each number correct to 1 significant figure, find an estimate for this calculation.

$$\begin{array}{l}
 \frac{22.1 \times 37}{1.9} \quad \approx \quad \frac{20 \times 40}{2} \\
 \\
 \approx \quad \frac{800}{2} = 400
 \end{array}$$

(b) ≈ 400 [3]

13 (a) Write 0.003 16 in standard form.

$\begin{matrix} \curvearrowright \curvearrowright \curvearrowright \\ 1 & 2 & 3 \end{matrix}$

(a) 3.16×10^{-3} [1]

(b) Work out.

$$2 \times 10^2 \times 4 \times 10^5$$

Give your answer in standard form.

$$2 \times 4 \times 10^{2+5}$$

=

(b) 8×10^7 [2]

14 The next term in each of these Fibonacci sequences is found by adding together the two previous terms.

Work out the missing terms in each sequence.

(a) 2 5 7 12 19 31 [1]

$\begin{matrix} \curvearrowright & \curvearrowright & \curvearrowright & \curvearrowright & & \curvearrowright \\ +3 & +2 & +5 & +7 & & +12 \\ & & & & & | \end{matrix}$

(b) 2 10 12 22 34 [2]

$\begin{matrix} & & \curvearrowright & \curvearrowright & \curvearrowright \\ & & +2 & +10 & +12 \end{matrix}$

15 (a) Multiply out.

$$(3x - 2y)(x + y)$$

Give your answer in its simplest form.

$$3x^2 + 3xy - 2yx - 2y^2$$

(a) $\dots\dots\dots 3x^2 + xy - 2y^2 \dots\dots\dots$ [3]

(b) $3(2x + d) + c(x + 5) = 10x + 17$

Work out the value of c and the value of d.

$$6x + 3d + cx + 5c = 10x + 17$$

$$(6+c)x + 3d+5c = 10x+17$$

$$6+c = 10$$

$$c = 4$$

$$3d+5c = 17$$

$$3d+20 = 17$$

$$3d = -3$$

$$d = -1$$

(b) $c = \dots\dots\dots 4 \dots\dots\dots$

$d = \dots\dots\dots -1 \dots\dots\dots$ [5]

(c) Solve by factorising.

$$x^2 - 7x + 10 = 0$$

$$\left. \begin{array}{l} \times \text{ to } 10 \\ + \text{ to } -7 \end{array} \right\} -5, -2$$

$$(x - 5)(x - 2) = 0$$

(c) $x = \dots\dots\dots 5 \dots\dots\dots$ or $x = \dots\dots\dots 2 \dots\dots\dots$ [3]

16 Geoff has two fair spinners.

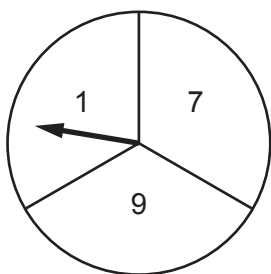

Spinner A

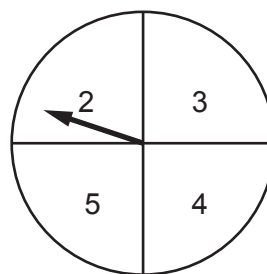

Spinner B

He spins both spinners and **multiplies** the numbers on each spinner.

(a) Complete the table.

		Spinner A				
		×	1	7	9	
Spinner B	2	2	14	18		
	3	3	21	27		
	4	4	28	36	9x4	
	5	5	35	45	9x5	

[1]

(b) Geoff wants to work out the probability that the outcome of the multiplication is an even number or a prime number. Here is his working.

The probability the outcome is an even number is $\frac{6}{12}$.

The probability the outcome is a prime number is $\frac{3}{12}$.

The probability the outcome is an even number or a prime number is $\frac{6}{12} + \frac{3}{12} = \frac{9}{12}$.

Geoff is wrong.
Explain his error and give the correct answer.

Even and prime aren't mutually exclusive. 2 is counted twice!

$\frac{8}{12}$

[2]

- 17 The depth of water in a garden pond is 57.8 cm.
The depth decreases by 0.3 cm per day.

(a) Assume the depth continues to decrease at the same rate.

After how many days will the depth reach 54.2 cm?

Depth Decrease : $57.8 - 54.2 = 3.6$

3.6 m

$3.6 \div 0.3 = 12$

(a) 12 days [3]

- (b) If the depth of water decreases at a slower rate, what effect will this have on your answer to part (a)?

..... It would take more days so the answer would be bigger [1]

- 18 Emily spent £2400 on holiday in 2017.
This was 20% more than she spent on holiday in 2016.

Calculate the amount she spent on holiday in 2016.

20% more : $20\% + 100\% = 120\%$

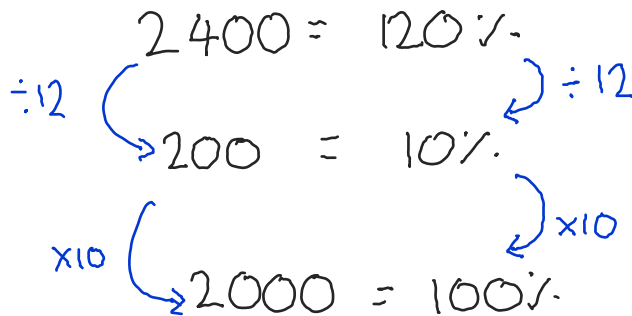

£ 2000 [3]

19 Triangle **A** and triangle **B** are drawn on the coordinate grid.

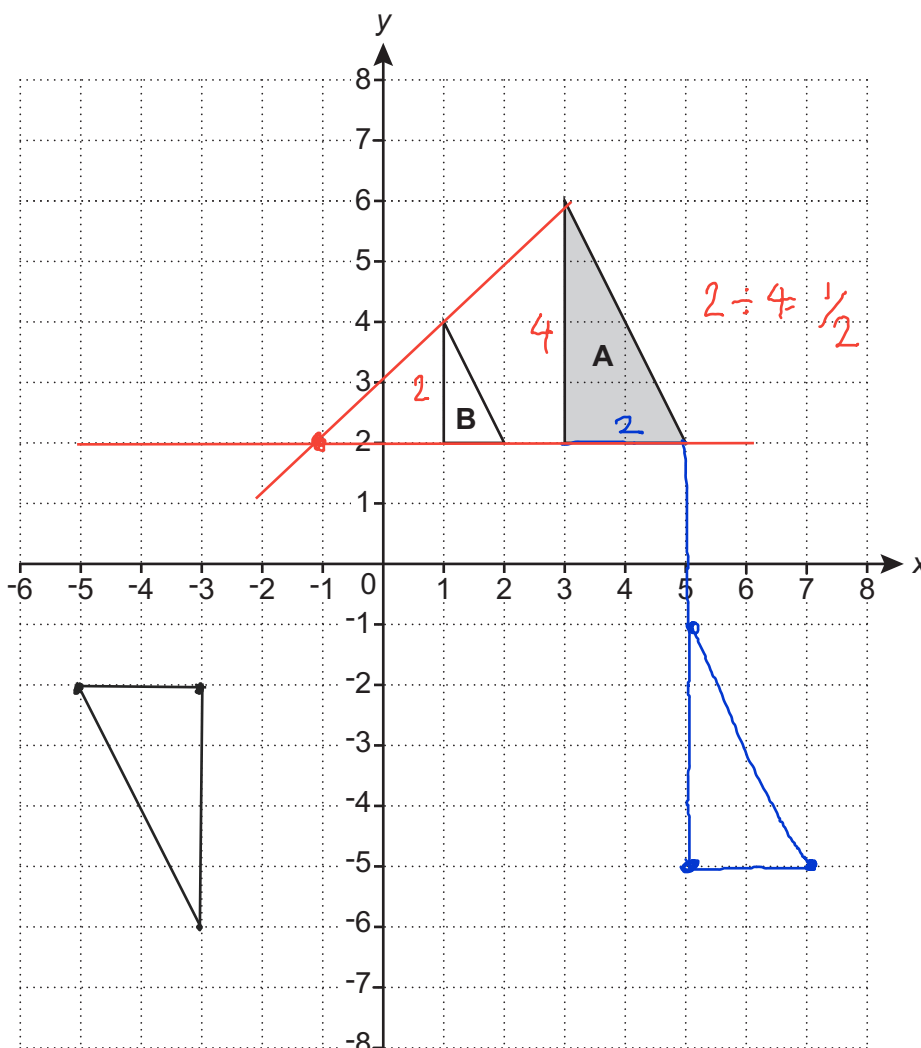

(a) (i) Draw the image of triangle **A** after a rotation of 180° about $(0, 0)$. [2]

(ii) Draw the image of triangle **A** after a translation by the vector $\begin{pmatrix} 2 \\ -7 \end{pmatrix}$. 2 right 7 down [2]

(b) Describe fully the **single** transformation that maps triangle **A** onto triangle **B**.

..... Enlargement, scale $\frac{1}{2}$ at
 point $(-1, 2)$ [3]

20 The table shows the number of computers sold in Tom's shop each quarter from 2015 to 2017.

	2015				2016				2017			
Quarter	1	2	3	4	1	2	3	4	1	2	3	4
Number of computers sold	13	31	29	45	20	32	25	47	27	40	30	58

(a) Complete this graph using the information for 2017.

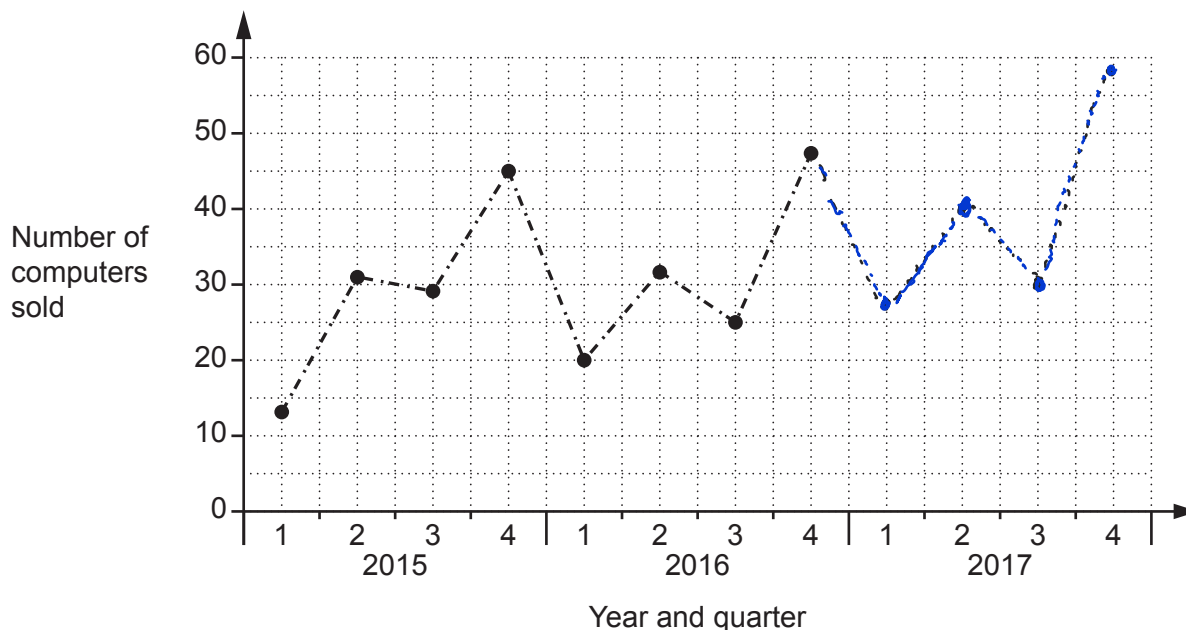

[2]

(b) Tom adds the three results for quarter 1 and he adds the three results for quarter 4. Tom says

The ratio of the **total** number of computers sold in quarter 1 compared to quarter 4 is 2 : 5.

Is he correct?

Show your reasoning.

Quarter 1 : $13 + 20 + 27 = 60$

Quarter 4 : $45 + 47 + 58 = 150$

$60 : 150$
 $(\div 30) \quad (\div 30)$
 $2 : 5$

He is correct

[2]

(c) Make two comments about Tom's sales over the period 2015 to 2017.

Comment 1 Increasing

Comment 2 Sales were weakest in 1st Quarter

[2]

(d) Tom predicts that he will sell more than 60 computers in the 4th quarter of 2018.

What assumption has he made?

..... The trend in his sales will continue

..... at a similar rate

[1]

21 A circle, with centre O and radius 6 cm, contains another circle, with centre O and radius x cm.

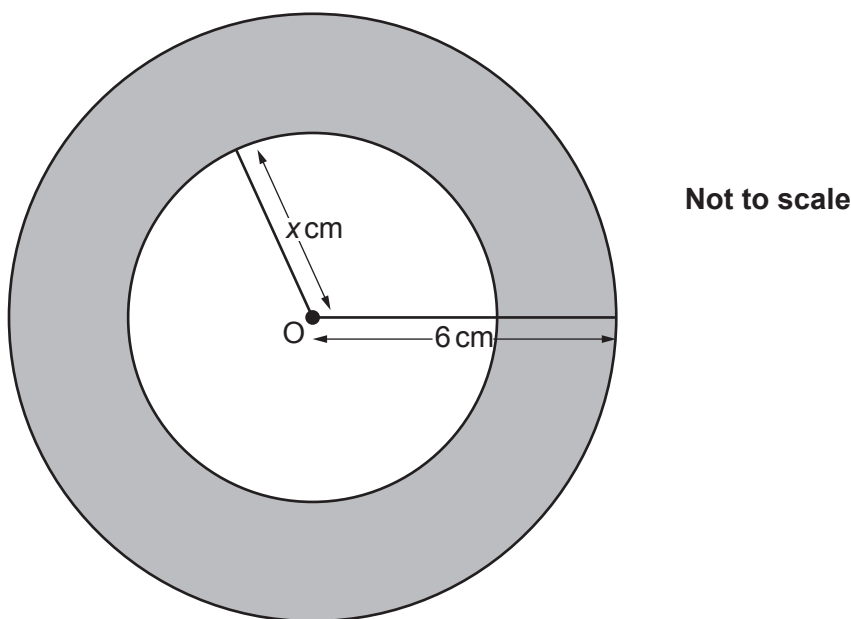

Write down an expression, in terms of π and x , for the shaded area in cm^2 .

Area of bigger circle: $\pi \times 6^2 = 36\pi$

Area of white circle: $\pi \times x^2 = x^2\pi$

shaded = $36\pi - x^2\pi$

..... $= \pi(36 - x^2)$ [2]

ADDITIONAL ANSWER SPACE

If additional space is required, you should use the following lined page(s). The question number(s) must be clearly shown in the margin(s).

A large rectangular area with a solid vertical line on the left side and horizontal dotted lines across the rest of the page, providing space for writing answers.



Copyright Information

OCR is committed to seeking permission to reproduce all third-party content that it uses in its assessment materials. OCR has attempted to identify and contact all copyright holders whose work is used in this paper. To avoid the issue of disclosure of answer-related information to candidates, all copyright acknowledgements are reproduced in the OCR Copyright Acknowledgements Booklet. This is produced for each series of examinations and is freely available to download from our public website (www.ocr.org.uk) after the live examination series.

If OCR has unwittingly failed to correctly acknowledge or clear any third-party content in this assessment material, OCR will be happy to correct its mistake at the earliest possible opportunity.

For queries or further information please contact The OCR Copyright Team, The Triangle Building, Shaftesbury Road, Cambridge CB2 8EA.

OCR is part of the Cambridge Assessment Group; Cambridge Assessment is the brand name of University of Cambridge Local Examinations Syndicate (UCLES), which is itself a department of the University of Cambridge.