

Tuesday 15 January 2013 – Afternoon

GCSE MATHEMATICS A

A501/02 Unit A (Higher Tier)

Candidates answer on the Question Paper.

OCR supplied materials:

None

Other materials required:

- Scientific or graphical calculator
- Geometrical instruments
- Tracing paper (optional)

Duration: 1 hour



Candidate forename		Candidate surname	
-----------------------	--	----------------------	--

Centre number						Candidate number				
---------------	--	--	--	--	--	------------------	--	--	--	--

INSTRUCTIONS TO CANDIDATES

- Write your name, centre number and candidate number in the boxes above. Please write clearly and in capital letters.
- Use black ink. HB pencil may be used for graphs and diagrams only.
- Answer **all** the questions.
- Read each question carefully. Make sure you know what you have to do before starting your answer.
- Your answers should be supported with appropriate working. Marks may be given for a correct method even if the answer is incorrect.
- Write your answer to each question in the space provided. Additional paper may be used if necessary but you must clearly show your candidate number, centre number and question number(s).
- Do **not** write in the bar codes.

INFORMATION FOR CANDIDATES

- The number of marks is given in brackets [] at the end of each question or part question.
- The total number of marks for this paper is **60**.
- This document consists of **16** pages. Any blank pages are indicated.

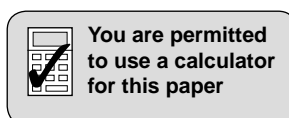

Formulae Sheet: Higher Tier

Area of trapezium = $\frac{1}{2}(a + b)h$

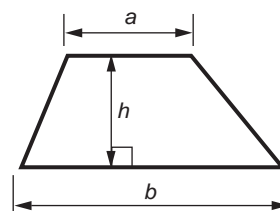

Volume of prism = (area of cross-section) \times length

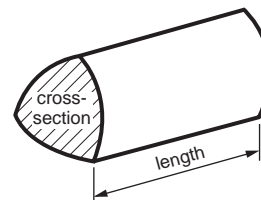

In any triangle ABC

Sine rule $\frac{a}{\sin A} = \frac{b}{\sin B} = \frac{c}{\sin C}$

Cosine rule $a^2 = b^2 + c^2 - 2bc \cos A$

Area of triangle = $\frac{1}{2}ab \sin C$

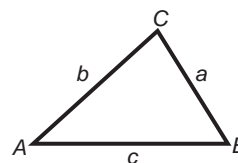

Volume of sphere = $\frac{4}{3}\pi r^3$

Surface area of sphere = $4\pi r^2$

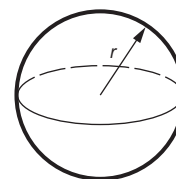

Volume of cone = $\frac{1}{3}\pi r^2 h$

Curved surface area of cone = $\pi r l$

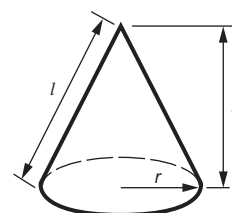

The Quadratic Equation

The solutions of $ax^2 + bx + c = 0$,
where $a \neq 0$, are given by

$$x = \frac{-b \pm \sqrt{b^2 - 4ac}}{2a}$$

PLEASE DO NOT WRITE ON THIS PAGE

3

- 1 In this question use a ruler, a protractor and a pair of compasses.
Do not rub out your construction lines.

This diagram shows a sketch of Salome's garden.

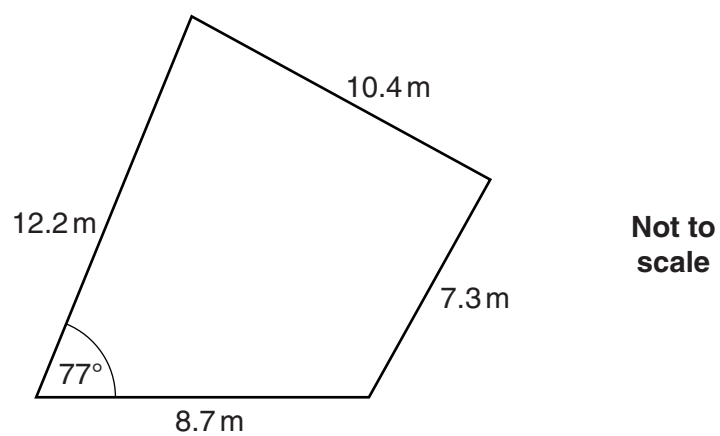

Salome wants to make a scale drawing of her garden.
Her drawing has been started below.

Complete her scale drawing.
Use the scale: 1 cm represents 1 metre.

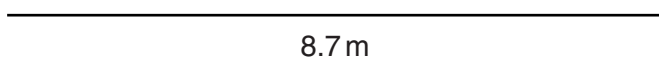

[4]

4

2 (a) Calculate.

$$\frac{(3.6 + 13.2)^2}{4.1^2 - 2.9^2}$$

(a) _____ [2]

(b) Insert brackets so that this calculation is correct.

$$4 + 5 \times 6^2 = 904 \quad [1]$$

(c) (i) Express 120 as a product of its prime factors.

(c)(i) _____ [2]

(ii) Find the least common multiple (LCM) of 120 and 42.

(ii) _____ [3]

5

3 (a) Multiply out.

$$6(3y + 5)$$

(a) _____ [1]

(b) Factorise.

$$5y - 15$$

(b) _____ [1]

(c) Solve.

$$7x - 2 = 5x + 11$$

(c) _____ [3]

6

- 4 (a) The students in group 11Y are raising money for charity. They have decided to share the money between three charities: Sustrans, Oxfam and the NSPCC.
The ratio Sustrans : Oxfam : NSPCC is 1 : 2 : 5.

- (i) Sally is a member of group 11Y.
She raises £72.

How much of this money will go to the NSPCC?

(a)(i) £ _____ [2]

- (ii) £360 goes to Oxfam from group 11Y.

How much money did group 11Y raise altogether?

(ii) £ _____ [2]

7

- (b) This table summarises the amount of money that the 30 members of group 11B raised for charity.

Amount (£ a)	Frequency
$0 \leq a < 20$	2
$20 \leq a < 40$	5
$40 \leq a < 60$	7
$60 \leq a < 80$	11
$80 \leq a < 100$	3
$100 \leq a < 120$	2

Calculate an estimate of the mean amount raised by a member of this group.

(b) £ _____ [4]

8

5 *Dave's Plumbing* charges £30 for a callout and £25 for each hour that a job takes.

(a) Write a formula for the total charge, £ C , that *Dave's Plumbing* makes for a job taking n hours.

(a) _____ [2]

(b) Mrs Brown was charged £92.50 for a job that *Dave's Plumbing* did.

How long did the job take?

(b) _____ hours [2]

9

6 The n th term of a sequence is $5n - 2$.

Find the largest number in the sequence which is less than 1000.
Find also which term in the sequence this number is.

The largest number in the sequence which is less than 1000 is _____ .

It is the _____ th term.

[3]

10

7 (a) Solve.

$$4x^2 = 36$$

(a) _____ [3]

(b) Rearrange this formula to make A the subject.

$$c = \sqrt{\frac{A}{6}}$$

(b) _____ [2]

11

- 8 The Jones family decides to buy a new TV. This sketch shows their old TV. The screen size of a TV is given as the length of its diagonal.

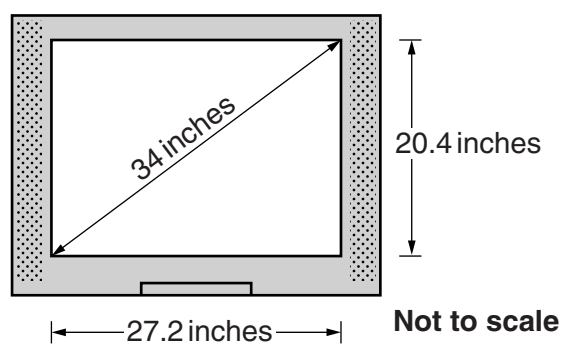

They decide to buy a new widescreen TV with the same screen height as their old one. The diagonal of the new TV is 42 inches, as shown in this sketch.

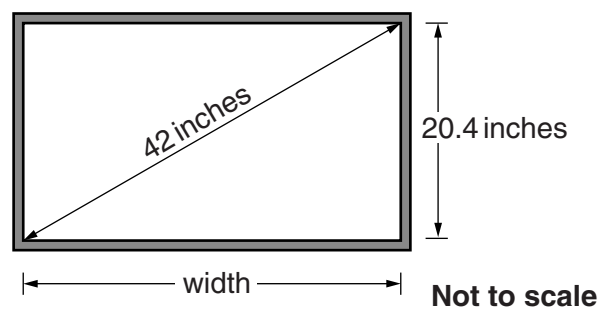

The screens of these TVs are rectangular.

Calculate how much wider, in inches, the screen on their new TV is than the screen on their old TV.

_____ inches [4]

12

- 9 The diagram shows the journey of a boat starting from A. To avoid rocks, the boat first travels 5 km on a bearing of 058° to B. It then travels from B to C. C is 12 km due east of A.

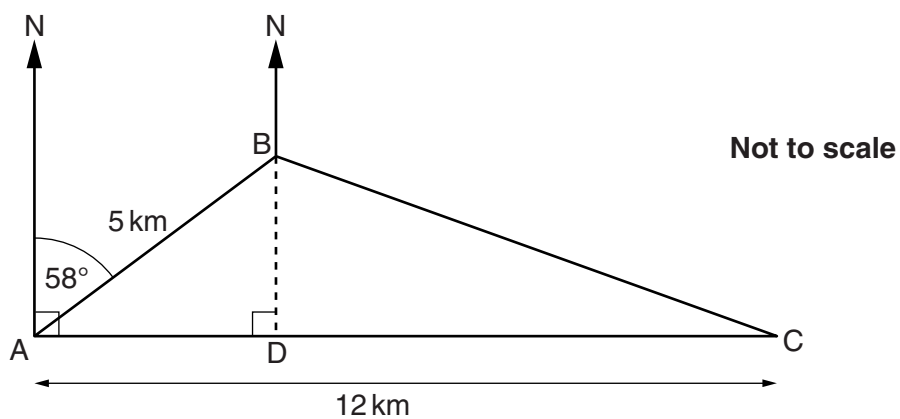

- (a) Show by calculation that AD, the distance that B is east of A, is 4.24 km correct to 2 decimal places.

[3]

13

(b) Calculate the bearing on which the boat travels from B to C.

(b) Bearing _____ ° [6]

14

- 10** This question is about solo swims of the English Channel. It uses data about the times, in hours, of the successful swims from England to France in 2009 and in 2010.

The boxplot drawn represents the times taken in 2009.

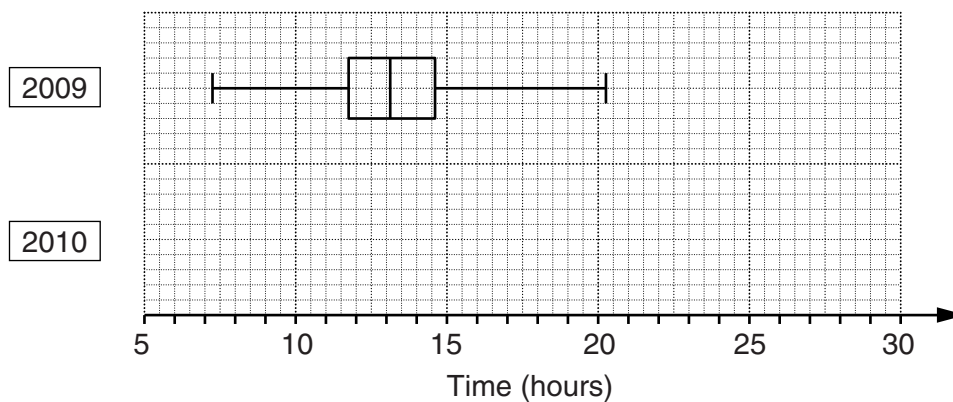

- (a)** Here is some summary information about the times in 2010.

Shortest time 7.7 hours

Lower quartile 12.7 hours

Range 21.0 hours

Median 14.4 hours

Interquartile range 4.0 hours

On the grid, draw the boxplot for the times of these channel swims in 2010.

[4]

15

(b) Comment on the truth, or otherwise, of each of the following statements. For each comment, include reasons in your answer. Give values to support your decision, where appropriate.

(i) On average, the swimmers took longer in 2010 than in 2009.

[1]

(ii) The swimmers' times were less varied in 2010 than in 2009.

[1]

(iii) There were more swimmers in 2010 than in 2009.

[1]

TURN OVER FOR QUESTION 11

16

11 You are given that $f(x) = ax - 6$ and that $f(2) = 9$.

Find the value of a and hence find $f(4)$.

$a =$ _____

$f(4) =$ _____ [3]

END OF QUESTION PAPER



Copyright Information

OCR is committed to seeking permission to reproduce all third-party content that it uses in its assessment materials. OCR has attempted to identify and contact all copyright holders whose work is used in this paper. To avoid the issue of disclosure of answer-related information to candidates, all copyright acknowledgements are reproduced in the OCR Copyright Acknowledgements Booklet. This is produced for each series of examinations and is freely available to download from our public website (www.ocr.org.uk) after the live examination series. If OCR has unwittingly failed to correctly acknowledge or clear any third-party content in this assessment material, OCR will be happy to correct its mistake at the earliest possible opportunity.

For queries or further information please contact the Copyright Team, First Floor, 9 Hills Road, Cambridge CB2 1GE.

OCR is part of the Cambridge Assessment Group; Cambridge Assessment is the brand name of University of Cambridge Local Examinations Syndicate (UCLES), which is itself a department of the University of Cambridge.