

Write your name here

Surname

Other names

Pearson
Edexcel GCSE

Centre Number

--	--	--	--	--

Candidate Number

--	--	--	--

Mathematics B

Unit 3: Number, Algebra, Geometry 2 (Calculator)

Foundation Tier

Tuesday 14 June 2016 – Morning

Time: 1 hour 30 minutes

Paper Reference

5MB3F/01

You must have: Ruler graduated in centimetres and millimetres, protractor, pair of compasses, pen, HB pencil, eraser, calculator. Tracing paper may be used.

Total Marks

Instructions

- Use **black** ink or ball-point pen.
- **Fill in the boxes** at the top of this page with your name, centre number and candidate number.
- Answer **all** questions.
- Answer the questions in the spaces provided – *there may be more space than you need.*
- **Calculators may be used.**
- If your calculator does not have a π button, take the value of π to be 3.142 unless the question instructs otherwise.



Information

- The total mark for this paper is 80
- The marks for **each** question are shown in brackets – *use this as a guide as to how much time to spend on each question.*
- Questions labelled with an **asterisk** (*) are ones where the quality of your written communication will be assessed.

Advice

- Read each question carefully before you start to answer it.
- Keep an eye on the time.
- Try to answer every question.
- Check your answers if you have time at the end.

Turn over ►

P46555A

©2016 Pearson Education Ltd.

6/6/6/4/



PEARSON

GCSE Mathematics 2MB01

Formulae: Foundation Tier

**You must not write on this formulae page.
Anything you write on this formulae page will gain NO credit.**

$$\text{Area of trapezium} = \frac{1}{2}(a + b)h$$

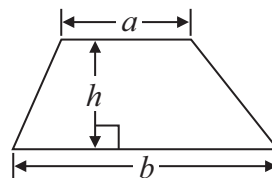

$$\text{Volume of prism} = \text{area of cross section} \times \text{length}$$

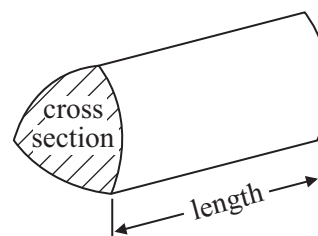

DO NOT WRITE IN THIS AREA

DO NOT WRITE IN THIS AREA

DO NOT WRITE IN THIS AREA



Answer ALL questions.

Write your answers in the spaces provided.

You must write down all stages in your working.

- 1 (a) Write $\frac{1}{4}$ as a decimal.

.....
(1)

- (b) Write 0.7 as a fraction.

.....
(1)

- (c) Write 42 out of 50 as a fraction.
Give your fraction in its simplest form.

.....
(2)

- (d) Write 120 as a percentage of 240

..... %
(1)

(Total for Question 1 is 5 marks)

DO NOT WRITE IN THIS AREA

DO NOT WRITE IN THIS AREA

DO NOT WRITE IN THIS AREA



2 The diagram shows the distances between 4 villages *C*, *H*, *S* and *Y* on a postman's round.

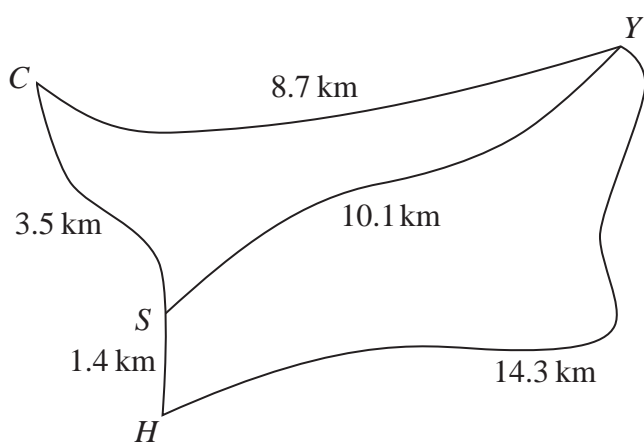

Diagram **NOT** accurately drawn

DO NOT WRITE IN THIS AREA

DO NOT WRITE IN THIS AREA

DO NOT WRITE IN THIS AREA

Gordon delivers letters to these 4 villages.

He starts and finishes at *C*.

Gordon wants to drive the shortest distance to deliver all his letters.

- (i) Work out this shortest distance.
You must show all your working.

..... km

- (ii) Write down Gordon's route.

.....

(Total for Question 2 is 4 marks)



DO NOT WRITE IN THIS AREA

DO NOT WRITE IN THIS AREA

DO NOT WRITE IN THIS AREA

3 Here are seven shapes shown on a grid.

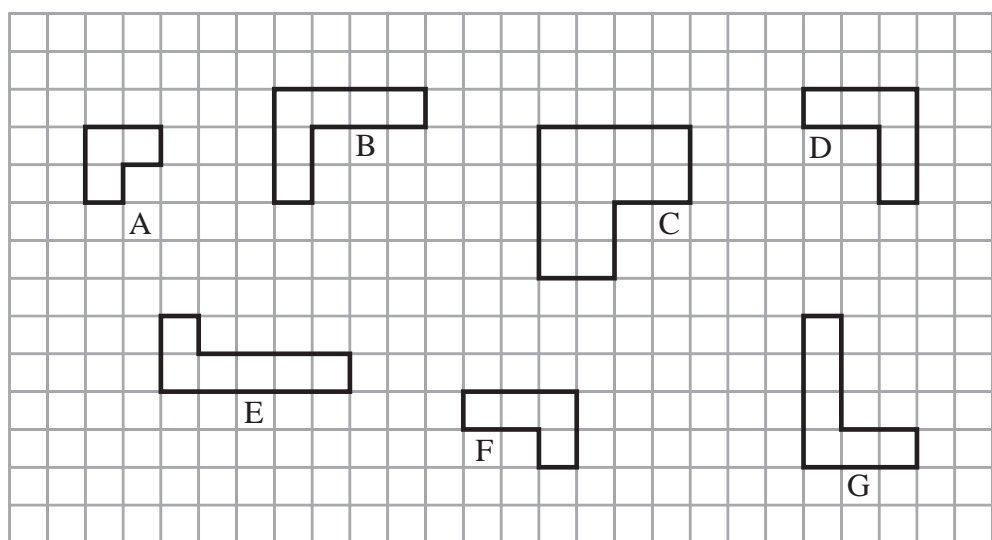

Two of the shapes are congruent.

(a) Write down the letters of these two shapes.

..... and
(1)

One of the shapes is similar to shape A.

(b) Write down the letter of the shape.

.....
(1)

(c) On the grid below, draw an enlargement of shape F with scale factor 3

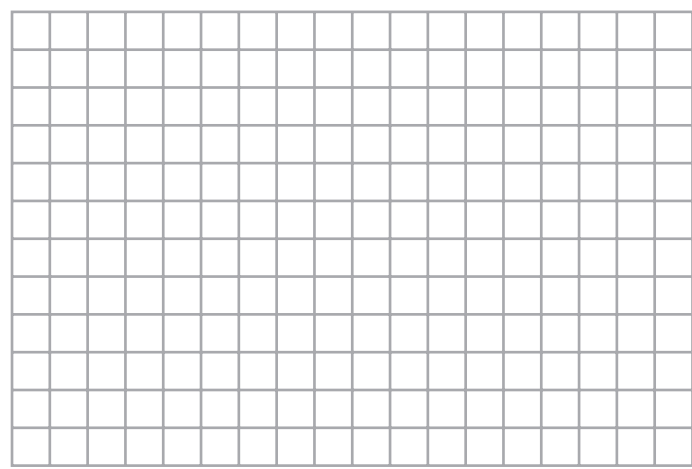

(2)

(Total for Question 3 is 4 marks)



- 4 Oliver orders some items from an electrical store.
Here is his bill.

(a) Complete the bill.

Live Wire Store			
Quantity	Item	Unit price	Total
2	Table lamps	£ 14.98	£ 29.96
5	Light switches	£ 6.40	£
.....	Light bulbs	£ 1.83	£ 21.96
Delivery charge			£ 5.00
Total cost			£

(3)

At the beginning of October, Oliver has £452.25 in his bank account.

During October, Oliver

puts £120 into his bank account
has £2.56 interest added to his bank account
spends £64.83 from his bank account.

- (b) How much money is in Oliver's bank account at the end of October?

£

(3)

(Total for Question 4 is 6 marks)

DO NOT WRITE IN THIS AREA

DO NOT WRITE IN THIS AREA

DO NOT WRITE IN THIS AREA



5 Here is a polygon.

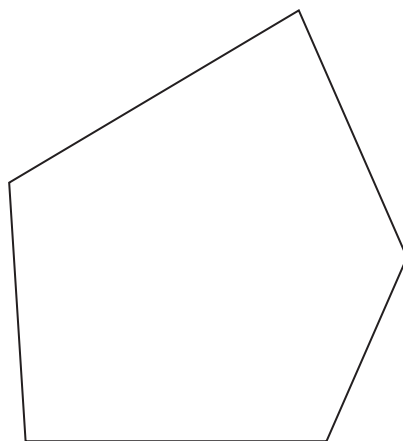

(a) Write down the mathematical name of this polygon.

.....
(1)

Here is a straight line.



(b) In the space above, draw a line parallel to this line.

(1)

(Total for Question 5 is 2 marks)

DO NOT WRITE IN THIS AREA

DO NOT WRITE IN THIS AREA

DO NOT WRITE IN THIS AREA



6

mirror line

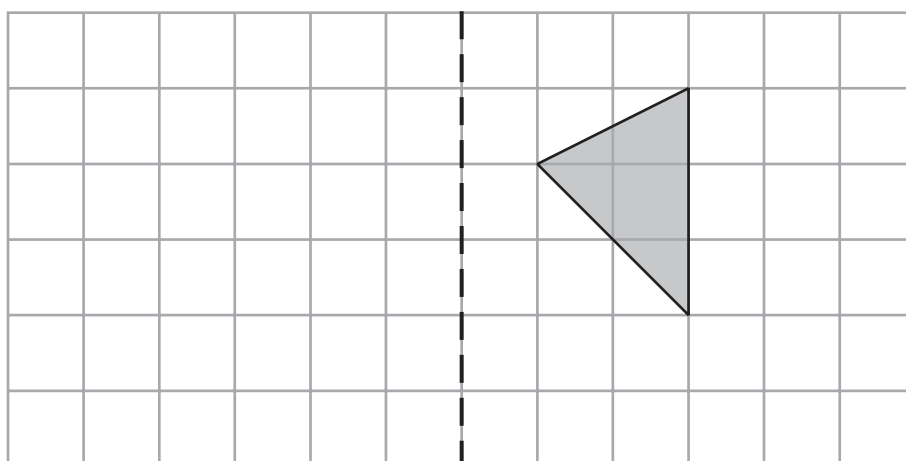

DO NOT WRITE IN THIS AREA

(a) Reflect the shape in the mirror line.

(1)

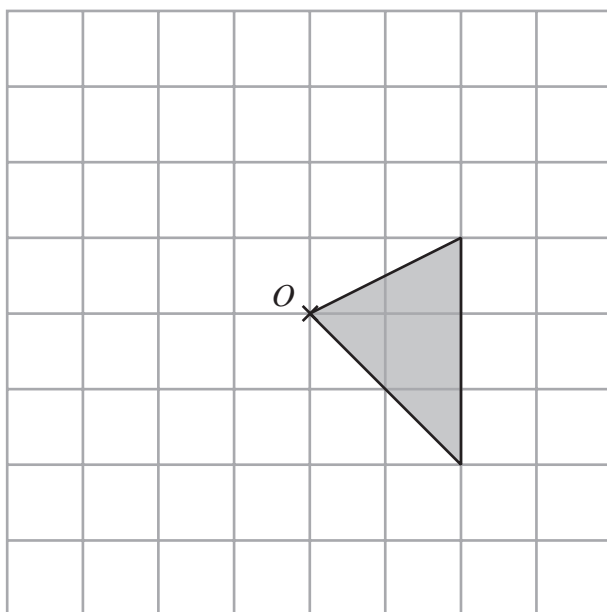

DO NOT WRITE IN THIS AREA

(b) Rotate the shape a quarter turn clockwise about O .

(2)

DO NOT WRITE IN THIS AREA

8



DO NOT WRITE IN THIS AREA

DO NOT WRITE IN THIS AREA

DO NOT WRITE IN THIS AREA

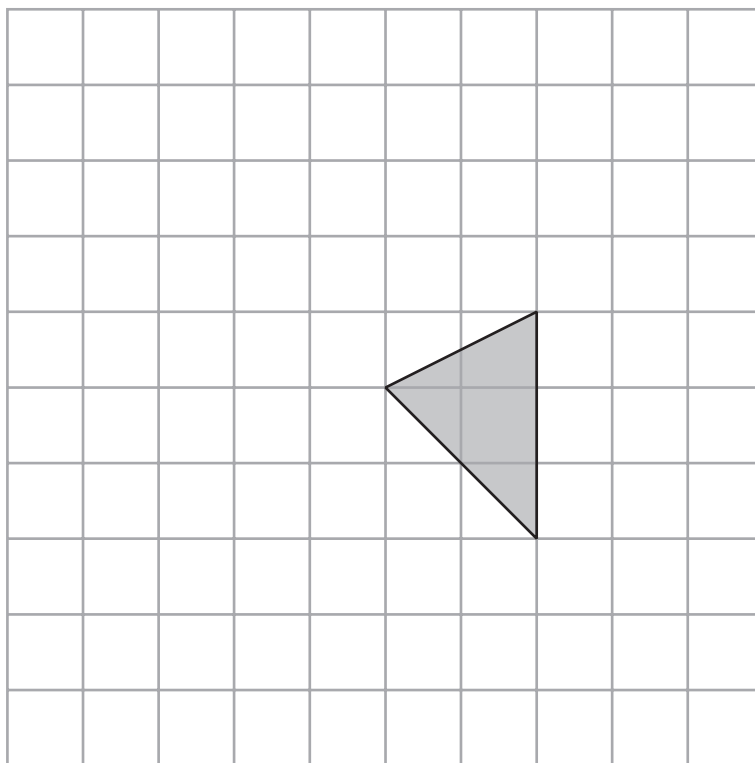

- (c) On the grid, show how the shape will tessellate.
You should draw at least 6 shapes.

(2)

(Total for Question 6 is 5 marks)

- 7 Karen had 5 boxes of pens.
There were 60 pens in each box.
Karen gave 8 teachers 35 pens each.
Work out how many pens Karen has left.

(Total for Question 7 is 3 marks)

- 8 Freya thinks of a number.
She multiplies the number by 2 and then subtracts 10
The result is 50

What number did Freya think of?

.....
(Total for Question 8 is 3 marks)

9 $p = 3u + \frac{1}{2}t$

$$u = -4$$

$$t = 18$$

Work out the value of p .

.....
(Total for Question 9 is 3 marks)

DO NOT WRITE IN THIS AREA

DO NOT WRITE IN THIS AREA

DO NOT WRITE IN THIS AREA



DO NOT WRITE IN THIS AREA

DO NOT WRITE IN THIS AREA

DO NOT WRITE IN THIS AREA

10 Here is a map showing three villages.

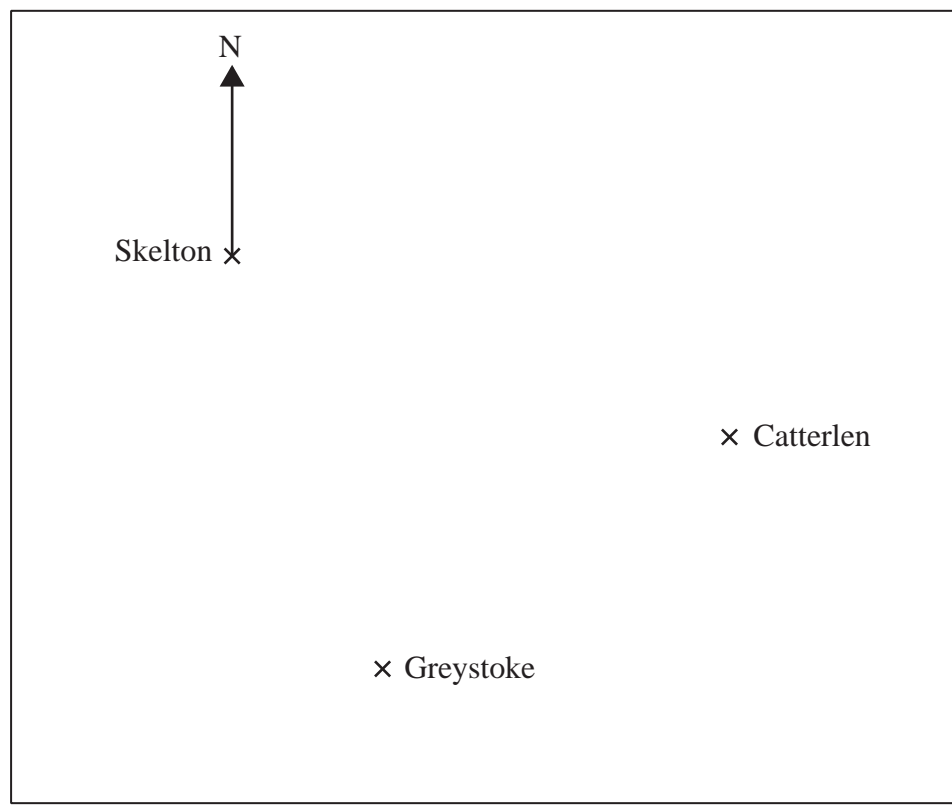

Scale: 1 cm represents 1 km.

(a) Work out the real distance from Catterlen to Skelton.

..... km
(1)

(b) Measure the bearing of Catterlen from Skelton.

..... °
(2)

A fourth village is the same distance from Greystoke as it is from Skelton.

(c) Mark with a cross (x) one possible position for this village.

(1)

(Total for Question 10 is 4 marks)



***11** Jon is planning a trip to the theatre for 24 people.

Here are the costs for the trip.

Hire of a coach	£258
Ticket	£27.50 per person
Meal	£8.50 per person

Jon is planning to charge each person £45 to cover the costs for the trip.

Is this enough?

You must show your working.

DO NOT WRITE IN THIS AREA

DO NOT WRITE IN THIS AREA

DO NOT WRITE IN THIS AREA

(Total for Question 11 is 3 marks)



12 A liquid is cooling.

The graph shows information about the time, in minutes, that the liquid has been cooling and its temperature in $^{\circ}\text{C}$.

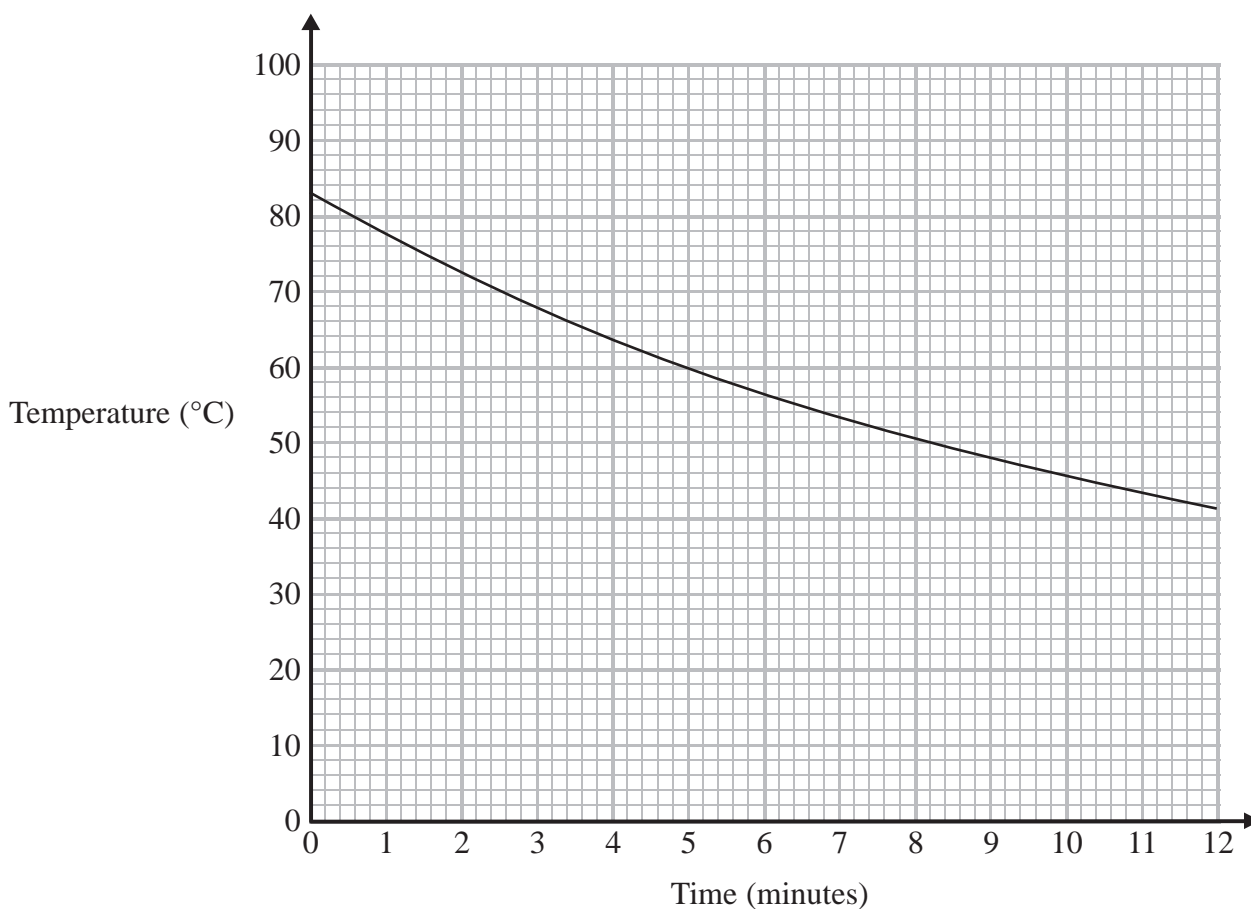

(a) Write down the temperature, in $^{\circ}\text{C}$, of the liquid when it started to cool.

..... $^{\circ}\text{C}$
(1)

It takes longer for the liquid to cool from 70°C to 60°C than it does for the liquid to cool from 80°C to 70°C .

(b) How much longer?

You must show how you get your answer.

..... minutes
(3)

(Total for Question 12 is 4 marks)



***13** Acres and hectares are units of area.

1 hectare = 2.47 acres

There are two farms for sale.

The area of farm A is 80 acres.

The area of farm B is 35 hectares.

Which farm has the greater area?

You must show all your working.

(Total for Question 13 is 3 marks)

DO NOT WRITE IN THIS AREA

DO NOT WRITE IN THIS AREA

DO NOT WRITE IN THIS AREA



14 (a) Solve $m - 5 = 8$

$$m = \dots\dots\dots$$

(1)

(b) Solve $7n = 21$

$$n = \dots\dots\dots$$

(1)

(c) Solve $\frac{t}{4} + 3 = 12$

$$t = \dots\dots\dots$$

(2)

(Total for Question 14 is 4 marks)

DO NOT WRITE IN THIS AREA

DO NOT WRITE IN THIS AREA

DO NOT WRITE IN THIS AREA



15 Here is a triangle.

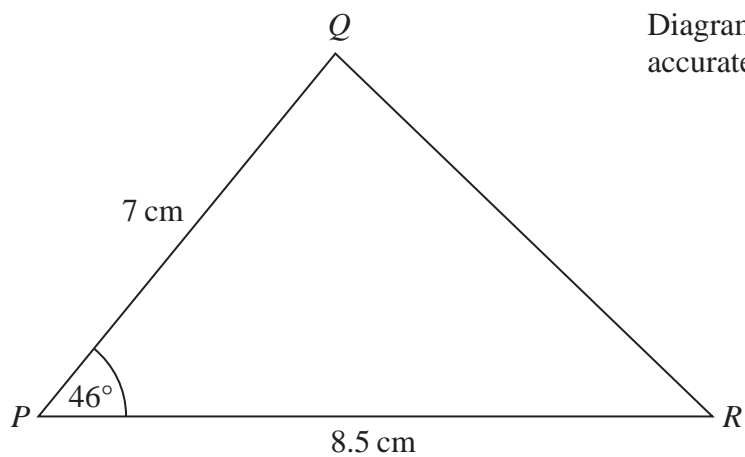

Diagram **NOT**
accurately drawn

Make an accurate drawing of triangle PQR .
The line PR has already been drawn for you.

P ————— R

(Total for Question 15 is 2 marks)

DO NOT WRITE IN THIS AREA

DO NOT WRITE IN THIS AREA

DO NOT WRITE IN THIS AREA



16 (a) Work out 7.5^2

.....
(1)

(b) Work out $\sqrt{20 - 9.76}$

.....
(1)

(Total for Question 16 is 2 marks)

DO NOT WRITE IN THIS AREA

DO NOT WRITE IN THIS AREA

DO NOT WRITE IN THIS AREA



17 Here is a map.

The map shows two towns Marlford (M) and Newborough (N).

A company is going to build a supermarket.

The supermarket will be more than 10 km from Marlford and less than 6 km from Newborough.

Find and shade the region on the map where the company can build the supermarket.

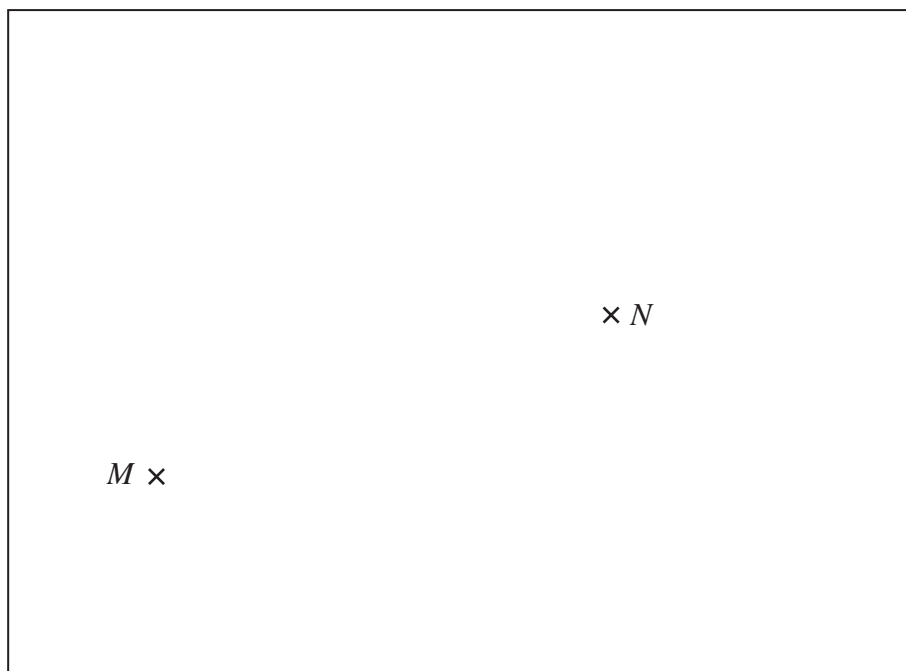

Scale: 1 cm represents 2 km.

(Total for Question 17 is 3 marks)

DO NOT WRITE IN THIS AREA

DO NOT WRITE IN THIS AREA

DO NOT WRITE IN THIS AREA



***18** 3 litres of juice are needed to fill 15 identical glasses.

Are 5 litres of juice enough to fill 24 of these glasses?

(Total for Question 18 is 3 marks)

DO NOT WRITE IN THIS AREA

DO NOT WRITE IN THIS AREA

DO NOT WRITE IN THIS AREA



P 4 6 5 5 5 A 0 1 9 2 4

19 The equation $x^3 + 5x = 70$ has a solution between 3 and 4

Use a trial and improvement method to find this solution.

Give your answer correct to one decimal place.

You must show all your working.

$x = \dots\dots\dots$

(Total for Question 19 is 4 marks)

DO NOT WRITE IN THIS AREA

DO NOT WRITE IN THIS AREA

DO NOT WRITE IN THIS AREA



20 Bhavin buys a car in a sale.

Before the sale, the cost of the car was £6720

In the sale, the cost of every car is reduced by 20%.

Bhavin pays a deposit of £1500

He will pay the rest of the cost in 24 equal monthly payments.

Work out the amount of each monthly payment.

You must show all your working.

£

(Total for Question 20 is 5 marks)



DO NOT WRITE IN THIS AREA

DO NOT WRITE IN THIS AREA

DO NOT WRITE IN THIS AREA

*21 The diagram shows the surface of a pond in the shape of a circle.

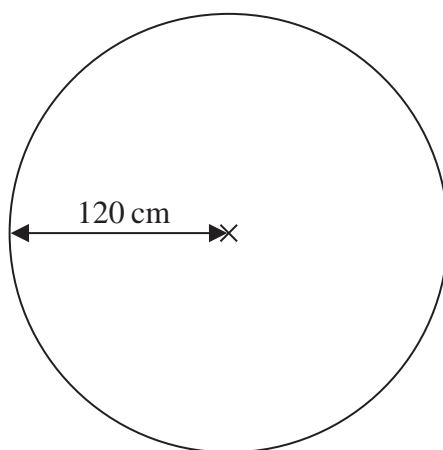

Diagram **NOT**
accurately drawn

The circle has a radius of 120 cm.

Mark wants to put 20 fish into the pond.

There needs to be a surface area of 1800 cm^2 for each fish.

Show that the surface of the pond is large enough for Mark to put 20 fish into the pond.

(Total for Question 21 is 4 marks)

DO NOT WRITE IN THIS AREA

DO NOT WRITE IN THIS AREA

DO NOT WRITE IN THIS AREA



22 PQR is an isosceles triangle.

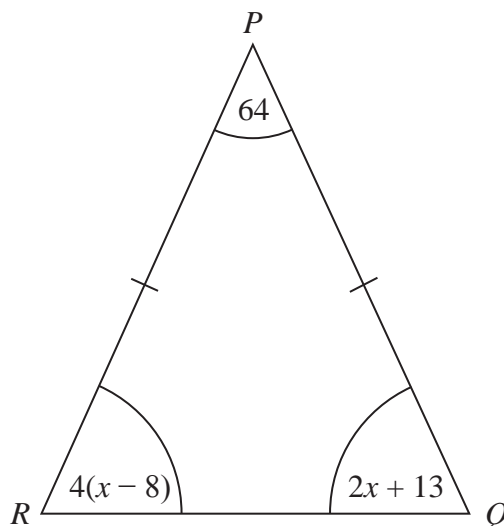

Diagram **NOT**
accurately drawn

$$PQ = PR$$

All the angles are in degrees.

Work out the value of x .

$$x = \dots\dots\dots$$

(Total for Question 22 is 4 marks)

TOTAL FOR PAPER IS 80 MARKS



DO NOT WRITE IN THIS AREA

DO NOT WRITE IN THIS AREA

DO NOT WRITE IN THIS AREA

DO NOT WRITE IN THIS AREA

DO NOT WRITE IN THIS AREA

DO NOT WRITE IN THIS AREA

BLANK PAGE

