

Please write clearly in block capitals.

Centre number

Candidate number

Surname \_\_\_\_\_

Forename(s) \_\_\_\_\_

Candidate signature \_\_\_\_\_

# GCSE MATHEMATICS

# F

Foundation Tier      Paper 2    Calculator

Thursday 8 June 2017

Morning

Time allowed: 1 hour 30 minutes

### Materials

For this paper you must have:

- a calculator
- mathematical instruments.

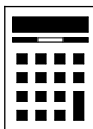

### Instructions

- Use black ink or black ball-point pen. Draw diagrams in pencil.
- Answer **all** questions.
- You must answer the questions in the spaces provided. Do not write outside the box around each page or on blank pages.
- Do all rough work in this book. Cross through any work you do not want to be marked.

### Information

- The marks for questions are shown in brackets.
- The maximum mark for this paper is 80.
- You may ask for more answer paper, graph paper and tracing paper. These must be tagged securely to this answer book.

### Advice

- In all calculations, show clearly how you work out your answer.

For Examiner's Use	
Pages	Mark
2–3	
4–5	
6–7	
8–9	
10–11	
12–13	
14–15	
16–17	
18–19	
20–21	
22–23	
24–25	
26	
<b>TOTAL</b>	



Answer **all** questions in the spaces provided

1 Which unit is most suitable for measuring the length of a tennis court?

Circle your answer.

[1 mark]

kilometres

too  
big

metres

centimetres

too small

millimetres

2 Circle the multiple of both 8 and 12 — in 8 and 12 times table

[1 mark]

4

32

72

108

$$\begin{aligned} 6 \times 12 &= 72 \\ 9 \times 8 &= 72 \end{aligned}$$

3 What is  $\frac{3}{2}$  as a decimal?

$$3 \div 2 = 2 \overline{) 3.0} \begin{array}{r} 1.5 \\ \underline{2} \phantom{0} \\ 10 \\ \underline{10} \\ 0 \end{array}$$

Circle your answer.

[1 mark]

1.05

1.1

1.5

3.2



4 Circle the correct statement.

$$\textcircled{-4 < -3}$$

X  
 $1 \leq -2$   
 1 is more  
 than -2

X  
 $-6 > 5$   
 -6 is less  
 than 5

[1 mark]  
 $-1 \geq 0$   
 -1 is less  
 than 0

5 (a) Use your calculator to work out  $\sqrt{701}$  as a decimal.

Write down your full calculator display.

[1 mark]

Answer 26.47640459

5 (b) Give your answer to part (a) to 1 decimal place.

7 > 5 round up

[1 mark]

Answer 26.5

Turn over for the next question

Turn over ►

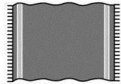

- 6** A swimming pool has three changing rooms, Male, Female and Family.  
The pictogram shows the number of people using each changing room during one hour.

Key:  represents 4 people

$$8 \div 2 = 4$$

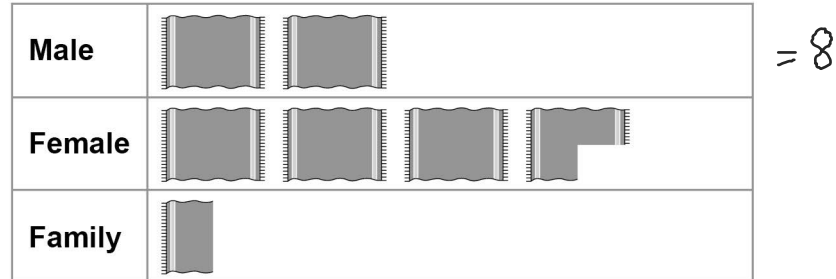

8 people used the Male changing room.

- 6 (a)** Complete the key.

[1 mark]

- 6 (b)** How many people used the Female changing room?

[1 mark]

$$4 + 4 + 4 + 3 = 15$$

Answer 15 females



6 (c) The manager has bought lockers for the changing rooms.

Why should she **not** use these results to decide where to put them?

[1 mark]

The sample was too small, there  
were only 25 people in the survey

7 Here is a list of numbers.

~~21~~ ~~17~~ ~~23~~ ~~21~~ ~~29~~ ~~32~~ ~~21~~ ~~25~~ ~~36~~

Work out the median.

[2 marks]

Order: 17, 21, 21, 21, 23, 25, 29, 32, 36  
1 2 3 4 4 3 2 1

Answer 23

Turn over for the next question



8 Here is a map of a town.

Scale: 1 cm represents 200 m

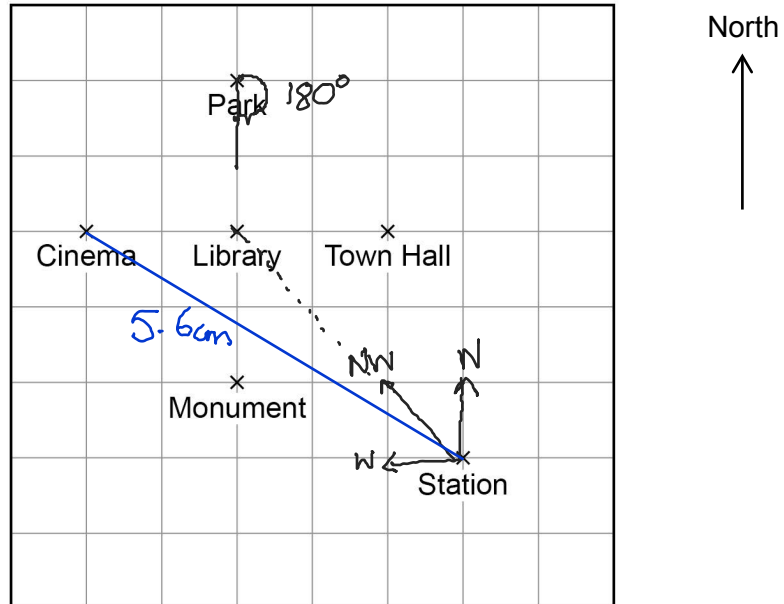

8 (a) Which place is exactly North West of the Station?  
Circle your answer.

[1 mark]

Cinema

Town Hall

Library

Park

Monument

8 (b) Circle the three-figure bearing of the Monument from the Park.

[1 mark]

090°

180°

270°

360°



8 (c) What is the distance, in metres, from the Cinema to the Station?

[3 marks]

$$\begin{array}{l} 1 \text{ cm} : 200 \text{ m} \quad \rightarrow \times 5.6 \\ 5.6 \text{ cm} : 1120 \text{ m} \end{array}$$

Answer 1120 metres

8 (d) Why might the shortest **walking** distance from the Cinema to the Station be greater than your answer to part (c)?

[1 mark]

You might not be able to walk in a straight line due to buildings

Turn over for the next question



9 Complete the bank statement.

[2 marks]

Date	Description	Credit (£)	Debit (£)	Balance (£)
13/12/2016	Starting balance			212.48
14/12/2016	Council tax		128.39	$212.48 - 128.39$ <u>84.09</u>
15/12/2016	Salary	856.21		$865.21 + 84.09$ <u>949.30</u>





10 The average age of teachers at a school is 36 years.

Mr Smith's age is  $\frac{11}{9}$  of the average.

How old is Mr Smith?

[2 marks]

$$\frac{11}{9} \text{ of } 36 = \frac{11}{9} \times 36 = \text{calc}$$

$$((36 \div 9) \times 11)$$

Answer 44 years

11 Solve  $4x - 3 = 14$

[2 marks]

$$4x - 3 = 14 \quad \rightarrow +3$$

$$4x = 17$$

$$x = \frac{17}{4}$$

$$x = \underline{4.25}$$

Turn over for the next question



12

Lee sells ice creams.

The table shows the midday temperature and his sales for five days.

	Day 1	Day 2	Day 3	Day 4	Day 5
Temperature (°C)	30	26	17	22	20
Sales (£)	180	150	80	130	120

12 (a)

He draws this scatter graph and line of best fit.

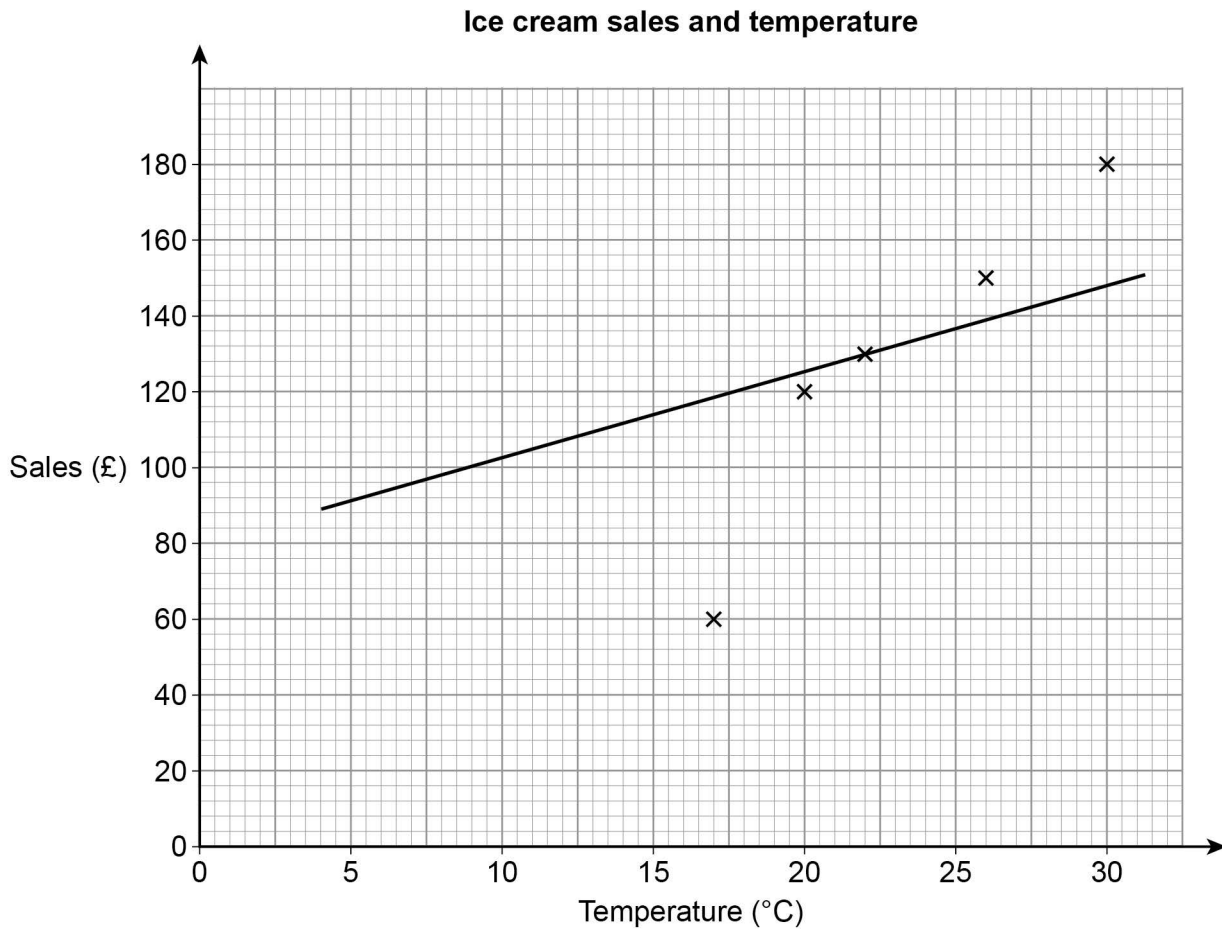
Write down **two** mistakes he has made.**[2 marks]**

Mistake 1 Day 3 (17, 80) has been plotted  
incomecting

Mistake 2 The line of best fit is outside the  
range of data points



**12 (b)** Lee wants to work out the range of the five temperatures.

His calculation is  $30 - 20 = 10$

Is his method correct?

Tick a box.

[1 mark]

Yes  No

Give a reason to support your answer.

Range = highest - lowest,  $20^{\circ}\text{C}$  is not  
the lowest value,  $17^{\circ}\text{C}$  is

**12 (c)** The table shows Lee's costs.

Ingredients	15% of sales
Fuel	£7 per day

Work out his total profit for the five days.

[5 marks]

$$\begin{aligned} \text{Total sales} &= 180 + 150 + 80 + 130 + 120 \\ &= £660 \end{aligned}$$

$$\text{Cost of ingredients} = 0.15 \times 660 = £99$$

$$\text{Fuel} = £7 \times 5 = £35$$

$$\text{Profit} = 660 - 99 - 35$$

Answer £ 526

Turn over ►

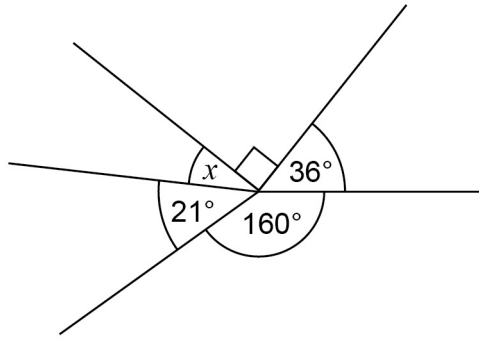

13

Not drawn  
accuratelyWork out the size of angle  $x$ .**[2 marks]**

Angle around a point =  $360^\circ$

$$360 - 90 - 36 - 160 - 21 = 53 = x$$

Answer 53 degrees





16 The counters in a bag are red or blue.

One fifth of the counters are red.

$$1 - \frac{1}{5} = \frac{4}{5} \text{ blue}$$

Work out the ratio red counters : blue counters

Circle your answer.

$$\begin{array}{l} \text{red: } \frac{1}{5} \\ \text{blue: } \frac{4}{5} \\ \hline 1 : 4 \end{array} \text{ [1 mark]}$$

$$\text{1 : 4}$$

$$1 : 5$$

$$4 : 5$$

$$1 : 6$$

17 Circle the fraction equal to 0.1%

[1 mark]

$$\frac{1}{10}$$

$$\frac{1}{100}$$

$$\frac{1}{1000}$$

$$\frac{1}{10000}$$

$$0.1\% \xrightarrow{\div 100} 0.001 = \frac{1}{1000}$$



18 Ellen works for a company that sells cars.

Her **monthly** pay is

- a salary of £1470
- 28% of the total **profit** the company makes from her sales
- a £250 bonus **if** she sells at least 15 cars.

The table shows information about the cars she sold last year.

Total cost to the company	Total income for the company	Number of months when she sold at least 15 cars
£464 500	£538 000	3

Was Ellen's total pay for the **year** more than £40 000?

You **must** show your working.

[6 marks]

$$\begin{array}{l} \text{Salary: } 12 \times 1470 = 17640 \\ \text{Bonus: } 3 \times 250 = 750 \end{array}$$

$$\begin{array}{l} \text{Profit of company: } 538,000 - 464,500 = 73,500 \\ \text{Ellen gets 28\%: } 0.28 \times 73,500 = 20,580 \end{array}$$

$$\begin{array}{l} 20580 + 750 + 17640 \\ = 38970 \end{array}$$

$$38970 < 40000$$

Answer     No    



19 Ben and Katy throw darts at a target.

Ben's ratio of hits to misses is 5 : 1

Katy's ratio of hits to misses is 3 : 1

Ben says,

"5 is bigger than 3, so I must have more hits than Katy."

Give an example to show that this might **not** be true.

[2 marks]

Katy could be 6:2 and Ben is 5:1.  
Katy hits 6 times, which is more than  
Ben's 5.

(The ratio may be simplified)





- 20** A code has 4 digits.  
Each digit is a number from 0 to 9  
Digits may be repeated.

The code starts 5 4 1

5	4	1	
---	---	---	--

- 20 (a)** Joe chooses a number at random for the last digit.

Write down the probability that he chooses the correct number.

[1 mark]

10 possibilities (0-9)  
1 correct

Answer \_\_\_\_\_

$$\frac{1}{10}$$

- 20 (b)** Amy knows the last digit is odd but not 7.  
She chooses a different odd number at random.

What is the probability that she chooses the correct number?

[1 mark]

odd: 1, 3, 5, 9 = 4 options  
1 correct

Answer \_\_\_\_\_

$$\frac{1}{4}$$

**Turn over for the next question**

**Turn over ►**



**21** Eva thinks she can save water by having a shower instead of a bath.

Eva's shower

uses 10.8 litres per minute

lasts for 8 minutes.

Eva assumes that the water in her bath is in the shape of this cuboid.

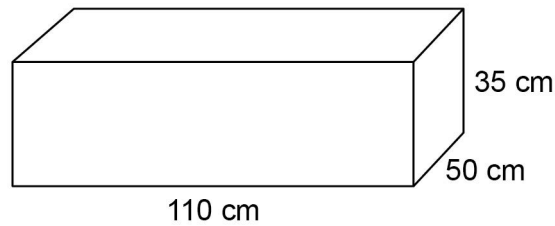

$1000 \text{ cm}^3 = 1 \text{ litre}$

**21 (a)** Using Eva's assumption, work out how many litres of water she saves by having a shower instead of a bath.

**[5 marks]**

$$\begin{aligned} \text{Water used in shower: } & 10.8 \text{ l} \times 8 \text{ min} \\ & = 86.4 \text{ l} \end{aligned}$$

$$\begin{aligned} \text{Bath: } & 110 \times 50 \times 35 = 192500 \text{ cm}^3 \div 1000 \\ & = 192.5 \text{ l} \end{aligned}$$

$$\text{Saves: } 192.5 - 86.4$$

$$\text{Answer } = \underline{106.1} \text{ litres}$$



- 21 (b)** A shows the water level before Eva gets into the bath.  
B shows the cuboid in the empty bath.

Not drawn  
accurately

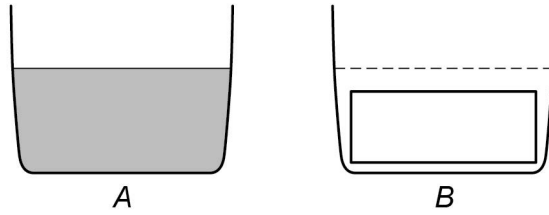

What does this tell you about the amount of water saved?

[1 mark]

The amount of water saved would be  
greater because the bath uses more  
water than the cuboid.

**Turn over for the next question**

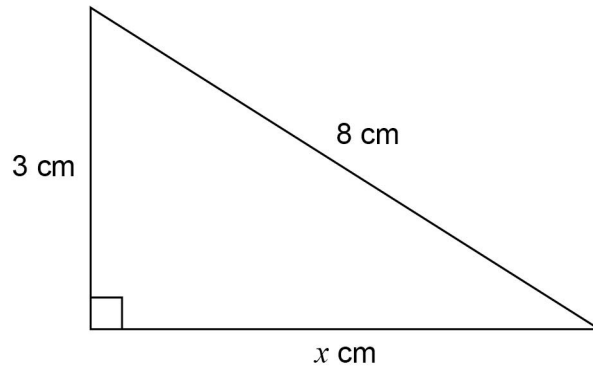

22

Not drawn  
accuratelyWork out the value of  $x$  as a decimal.**[3 marks]**

$$\text{Pythagoras: } a^2 + b^2 = c^2$$

$$x^2 + 3^2 = 8^2$$

$$x^2 = 8^2 - 3^2$$

$$x^2 = 55$$

$$x = \sqrt{55}$$

$$= 7.42$$

Answer 7.42

23

Lily goes on a car journey.

$$\text{speed} = \frac{\text{distance}}{\text{time}}$$

$$D = 40 \times \frac{1}{2}$$

For the first 30 minutes <sup>1/2h</sup> her average speed is 40 miles per hour.

She then stops for 15 minutes.

She then completes the journey at an average speed of 60 miles per hour.

The total journey time is 1 hour.  $- 15 \text{ min} = \frac{1}{4} \text{ h}$

$$\text{distance} = \frac{1}{4} \times 60 = 15$$

23 (a) Draw a distance-time graph for her journey.

[3 marks]

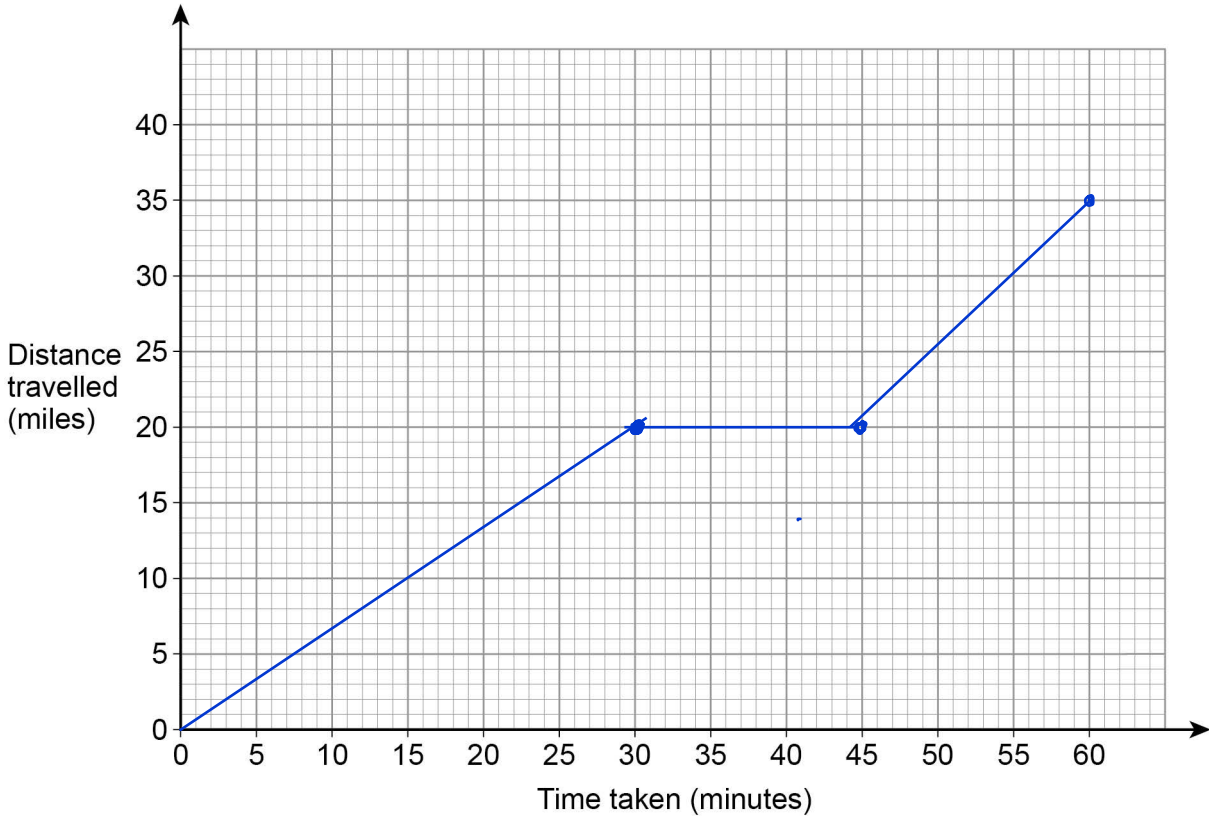

23 (b) Write down the average speed for the total journey.

[1 mark]

$$\text{Avg speed} = \frac{\text{Total distance}}{\text{Total Time}} = \frac{35 \text{ miles}}{1 \text{ hour}}$$

Answer 35 mph

Turn over for the next question

Turn over ►





25 The table shows information about some CDs.

Type	Rock	Pop	Jazz
Number of CDs	2	$x$	$2x + 5$

A CD is chosen at random.

The probability it is **rock** is  $\frac{1}{20}$

Work out the probability it is jazz.

[4 marks]

$$\frac{2}{2+x+2x+5} = \frac{1}{20}$$

cross multiply

$$\frac{2}{3x+7} = \frac{1}{20}$$

$$40 = 3x + 7$$

$$33 = 3x$$

$$11 = x$$

$$\text{prob(Jazz)} = \frac{2(11)+5}{40}$$

$$= \frac{22+5}{40}$$

Answer  $\frac{27}{40}$

Turn over for the next question

Turn over ►



26 (a) Complete the table of values for  $y = x^2 - x - 2$

[2 marks]

$$4 + 2 - 2 \quad 1 + 1 - 2$$

$$4 - 2 - 2$$

$x$	-2	-1	0	1	2	3
$y$	4	0	-2	-2	0	4

26 (b) Draw the graph of  $y = x^2 - x - 2$  for values of  $x$  from -2 to 3

[2 marks]

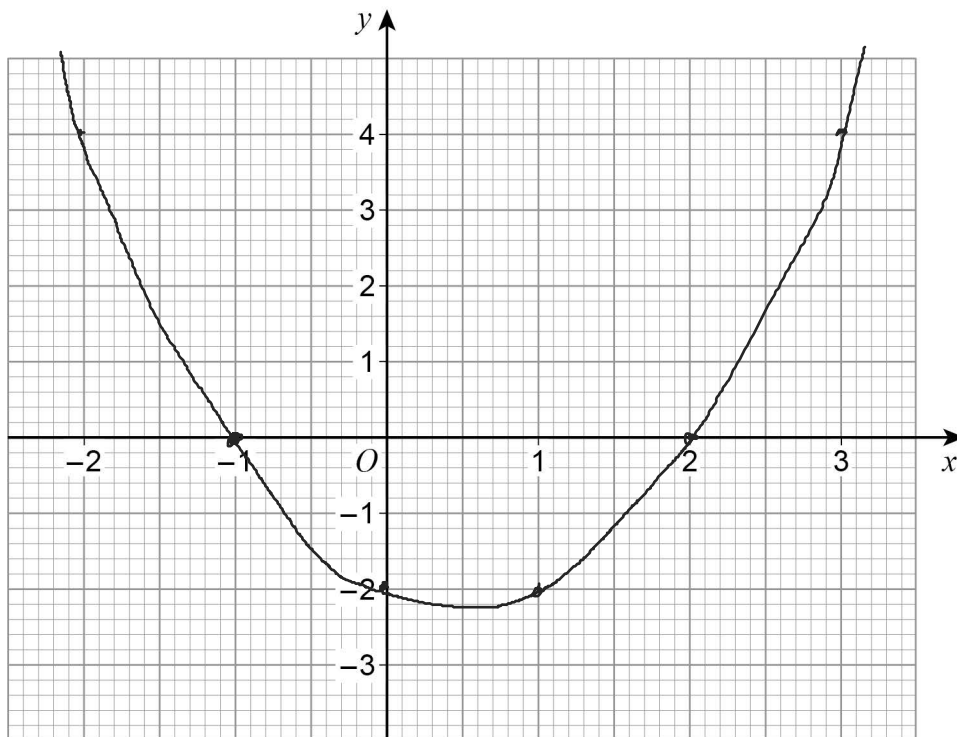



27 Write these numbers in **descending** order.

$$\begin{array}{c} 2 \\ 9563 \end{array}$$

$$\begin{array}{c} 3 \\ 9.56 \times 10^3 \\ 1 \\ 9560 \end{array}$$

$$\begin{array}{c} 1 \\ 9.56 \times 3^{10} \\ 1 \\ 56450.44 \end{array}$$

[2 marks]

Answer  $9.56 \times 3^{10}$  ,  $9563$  ,  $9.56 \times 10^3$

28 Rearrange  $y = \frac{x}{3} + 9$  to make  $x$  the subject.

$$\begin{array}{c} -9 \\ -9 \end{array} \frac{x}{3}$$

[2 marks]

$$\begin{array}{c} y - 9 = \frac{x}{3} \\ \times 3 \quad \times 3 \end{array}$$

$$3(y - 9) = x$$

Answer  $x = 3y - 27$

Turn over for the next question

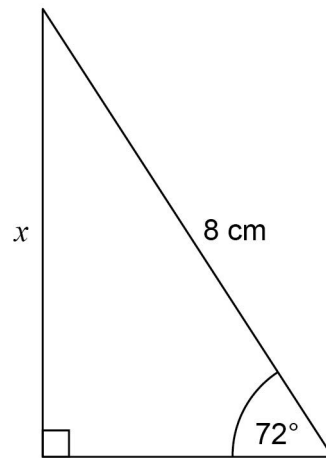

29

Use trigonometry to work out the length  $x$ .Not drawn  
accurately

[2 marks]

$$\sin \theta = \frac{\text{opp}}{\text{hyp}}$$

$$\sin 72 = \frac{x}{8}$$

$$x = 8 \sin 72$$

Answer 7.61 cm**END OF QUESTIONS**

**There are no questions printed on this page**

**DO NOT WRITE ON THIS PAGE  
ANSWER IN THE SPACES PROVIDED**



**There are no questions printed on this page**

**DO NOT WRITE ON THIS PAGE  
ANSWER IN THE SPACES PROVIDED**

**Copyright Information**

For confidentiality purposes, from the November 2015 examination series, acknowledgements of third party copyright material will be published in a separate booklet rather than including them on the examination paper or support materials. This booklet is published after each examination series and is available for free download from [www.aqa.org.uk](http://www.aqa.org.uk) after the live examination series.

Permission to reproduce all copyright material has been applied for. In some cases, efforts to contact copyright-holders may have been unsuccessful and AQA will be happy to rectify any omissions of acknowledgements. If you have any queries please contact the Copyright Team, AQA, Stag Hill House, Guildford, GU2 7XJ.

Copyright © 2017 AQA and its licensors. All rights reserved.

