

1.

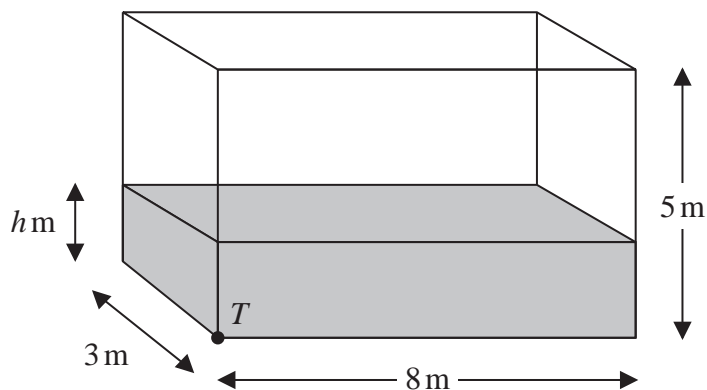

Figure 5

Water flows at a constant rate into a large tank.

The tank is a cuboid, with all sides of negligible thickness.

The base of the tank measures 8 m by 3 m and the height of the tank is 5 m.

There is a tap at a point T at the bottom of the tank, as shown in Figure 5.

At time t minutes after the tap has been opened

- the depth of water in the tank is h metres
- water is flowing into the tank at a constant rate of 0.48 m^3 per minute
- water is modelled as leaving the tank through the tap at a rate of $0.1h \text{ m}^3$ per minute

(a) Show that, according to the model,

$$1200 \frac{dh}{dt} = 24 - 5h \quad (4)$$

Given that when the tap was opened, the depth of water in the tank was 2 m,

(b) show that, according to the model,

$$h = A + Be^{-kt}$$

where A , B and k are constants to be found. (6)

Given that the tap remains open,

(c) determine, according to the model, whether the tank will ever become full, giving a reason for your answer. (2)

DO NOT WRITE IN THIS AREA

DO NOT WRITE IN THIS AREA

DO NOT WRITE IN THIS AREA



3.

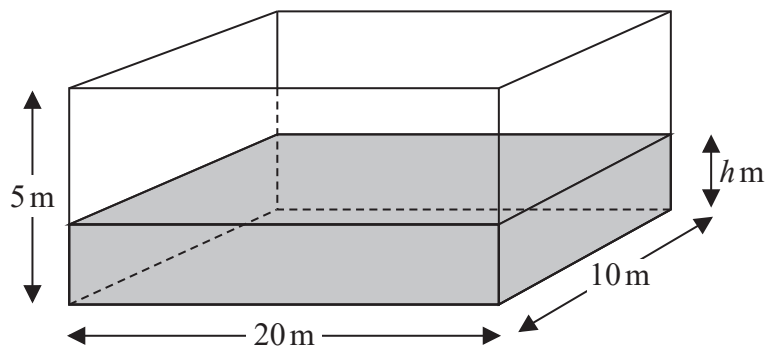

Figure 1

A tank in the shape of a cuboid is being filled with water.

The base of the tank measures 20 m by 10 m and the height of the tank is 5 m, as shown in Figure 1.

At time t minutes after water started flowing into the tank the height of the water was h m and the volume of water in the tank was V m³

In a model of this situation

- the sides of the tank have negligible thickness
- the rate of change of V is inversely proportional to the square root of h

(a) Show that

$$\frac{dh}{dt} = \frac{\lambda}{\sqrt{h}}$$

where λ is a constant.

(3)

Given that

- initially the height of the water in the tank was 1.44 m
- exactly 8 minutes after water started flowing into the tank the height of the water was 3.24 m

(b) use the model to find an equation linking h with t , giving your answer in the form

$$h^{\frac{3}{2}} = At + B$$

where A and B are constants to be found.

(5)

(c) Hence find the time taken, from when water started flowing into the tank, for the tank to be completely full.

(2)

DO NOT WRITE IN THIS AREA

DO NOT WRITE IN THIS AREA

DO NOT WRITE IN THIS AREA

