



Oxford Cambridge and RSA

**Tuesday 19 October 2021 – Afternoon**

**AS Level Further Mathematics B (MEI)**

**Y415/01 Mechanics b**

**Time allowed: 1 hour 15 minutes**



**You must have:**

- the Printed Answer Booklet
- the Formulae Booklet for Further Mathematics B (MEI)
- a scientific or graphical calculator

**INSTRUCTIONS**

- Use black ink. You can use an HB pencil, but only for graphs and diagrams.
- Write your answer to each question in the space provided in the **Printed Answer Booklet**. You can use extra paper if you need to, but you must clearly show your candidate number, the centre number and the question numbers.
- Fill in the boxes on the front of the Printed Answer Booklet.
- Answer **all** the questions.
- Where appropriate, your answer should be supported with working. Marks might be given for using a correct method, even if your answer is wrong.
- Give your final answers to a degree of accuracy that is appropriate to the context.
- The acceleration due to gravity is denoted by  $g \text{ m s}^{-2}$ . When a numerical value is needed use  $g = 9.8$  unless a different value is specified in the question.
- Do **not** send this Question Paper for marking. Keep it in the centre or recycle it.

**INFORMATION**

- The total mark for this paper is **60**.
- The marks for each question are shown in brackets [ ].
- This document has **8** pages.

**ADVICE**

- Read each question carefully before you start your answer.

Answer **all** the questions.

- 1 The end O of a light elastic string OA is attached to a fixed point.

Fiona attaches a mass of 1 kg to the string at A. The system hangs vertically in equilibrium and the length of the stretched string is 70 cm.

Fiona removes the 1 kg mass and attaches a mass of 2 kg to the string at A. The system hangs vertically in equilibrium and the length of the stretched string is now 80 cm.

Fiona then removes the 2 kg mass and attaches a mass of 5 kg to the string at A. The system hangs vertically in equilibrium.

- (a) Use the information given in the question to determine expected values for

- the length of the stretched string when the 5 kg mass is attached,
- the elastic potential energy stored in the string in this case. [7]

Fiona discovers that, when the mass of 5 kg is attached to the string at A, the length of the stretched string is greater than the expected length.

- (b) Suggest a reason why this has happened. [1]

- 2 A particle, Q, moves so that its velocity,  $\mathbf{v}$ , at time  $t$  is given by  $\mathbf{v} = (6t - 6)\mathbf{i} + (3 - 2t + t^2)\mathbf{j} + 4\mathbf{k}$ , where  $0 \leq t \leq 6$ .

- (a) Explain how you know that Q is never stationary. [1]

When Q is at a point A the direction of the acceleration of Q is parallel to the  $\mathbf{i}$  direction.

When Q is at a point B the direction of the acceleration of Q makes an angle of  $45^\circ$  with the  $\mathbf{i}$  direction.

- (b) Determine the straight-line distance AB. [7]

**3 In this question you must show detailed reasoning.**

[In this question you may use the formula: Volume of cone =  $\frac{1}{3} \times$  base area  $\times$  height.]

The region between the line  $y = -3x + 3a$ , where  $a > 0$ , the  $x$ -axis and the  $y$ -axis is rotated about the  $y$ -axis to form a uniform right circular cone  $C$  with base radius  $a$ .

(a) Show that the centre of mass of  $C$  is  $\frac{3}{4}a$  from its base. [5]

The cone  $C$  is fixed on top of a uniform cube,  $B$ , of edge length  $2a$ , so that there is no overlap. Fig. 3.1 shows a side view of  $C$  and  $B$  fixed together; Fig. 3.2 shows a view of  $C$  and  $B$  from above.

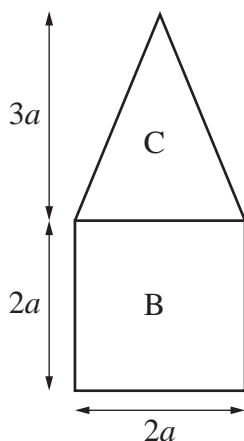

**Fig. 3.1**

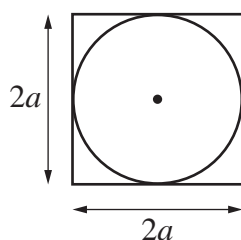

**Fig. 3.2**

The centre of mass of the combined shape lies on the boundary of  $C$  and  $B$ .

The density of  $B$  is **not** equal to the density of  $C$ .

(b) Determine the exact value of  $\frac{\text{density of } C}{\text{density of } B}$ . [3]

## 4

- 4 Two small smooth discs, A of mass  $0.5\text{ kg}$  and B of mass  $0.4\text{ kg}$ , collide while sliding on a smooth horizontal plane.

Immediately before the collision A and B are moving towards each other, A with speed  $0.5\text{ m s}^{-1}$  and B with speed  $0.6\text{ m s}^{-1}$ .

Before the collision the direction of motion of A makes an angle  $\alpha$  with the line of centres, where  $\tan \alpha = 0.75$ , and the direction of motion of B makes an angle of  $60^\circ$  with the line of centres, as shown in Fig. 4.

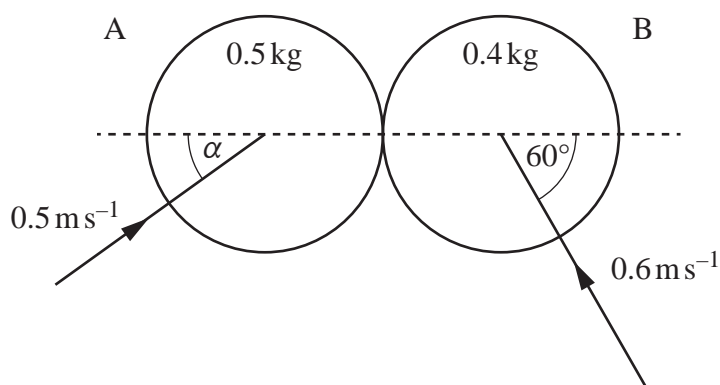

**Fig. 4**

After the collision, one of the discs moves in a direction perpendicular to the line of centres, and the other disc moves in a direction making an angle  $\beta$  with the line of centres.

- (a) Explain why the disc which moves perpendicular to the line of centres must be A. [1]
- (b) Determine the value of  $\beta$ . [4]
- (c) Determine the kinetic energy lost in the collision. [3]
- (d) Determine the value of the coefficient of restitution between A and B. [3]

- 5 On a fairground ride, the centre of a horizontal circular frame is attached to the top of a vertical pole, OP. When the frame and pole rotate, OP remains vertical and the frame remains horizontal.

Chairs of mass 10 kg are attached to the frame by means of chains of length 2.5 m. The chains are modelled as being both light and inextensible.

A side view of the situation when the ride is stationary is shown in Fig. 5. A chain fixed to point A on the circular frame supports a chair. The distance OA is 2 m.

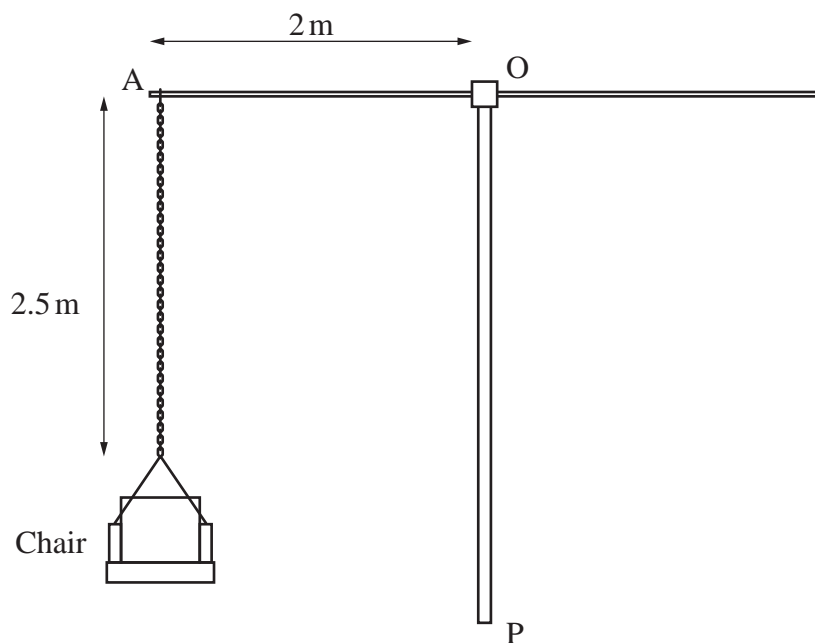

**Fig. 5**

A child of mass 40 kg sits in a chair and, after a short time, the ride is rotating at a steady angular speed of  $\omega$  radians per second, with the chain inclined at an angle of  $50^\circ$  to the downward vertical. The motion of the child and chair is in a horizontal circle.

- (a) Draw a sketch showing the forces acting on the chair when the ride is moving at this angular speed. [1]
- (b) • Determine the tension in the chain.  
• Determine the value of  $\omega$ . [6]

On another occasion, a man of mass 90 kg sits in the chair; after a short time, the ride is rotating in a horizontal circle at a steady speed of  $\omega$  radians per second, with the chain inclined at the same angle of  $50^\circ$  to the downward vertical.

- (c) Without any detailed calculations, explain how your answers to part (b) for the child would compare with those for the man. [2]
- (d) Explain why the chain is modelled as light. [1]
- (e) State **two** other modelling assumptions that were used in answering part (b). [2]

- 6 A section of a golf practice ground is inclined at  $15^\circ$  to the horizontal. A golfer is hitting a ball up and down a line of greatest slope of this section of the practice ground.

The golfer hits the ball up the slope, so that the ball initially makes an angle of  $30^\circ$  with the slope. The ball first bounces on the slope 50 m from its point of projection.

- (a) Determine the initial speed of the ball. [6]

The golfer now hits the ball down the slope. The ball initially moves with speed  $20 \text{ m s}^{-1}$  and the ball initially travels at an angle  $\theta$  above the horizontal, as shown in Fig. 6. The ball first bounces at a point a distance  $L \text{ m}$  down the slope.

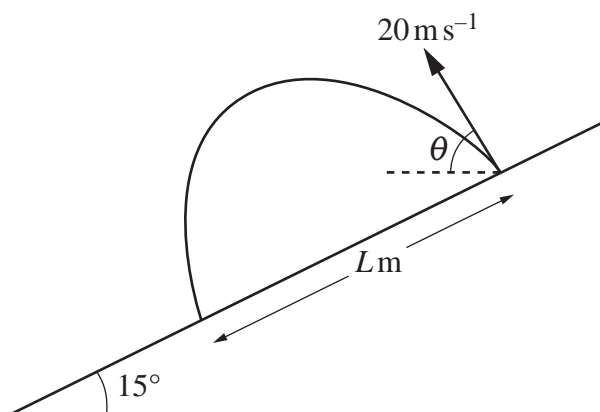

Fig. 6

- (b) Show that  $L = \frac{800}{g} \left( \frac{\sin \theta \cos \theta}{\cos 15^\circ} + \frac{\sin 15^\circ \cos^2 \theta}{\cos^2 15^\circ} \right)$ . [4]

You are given that  $\frac{dL}{d\theta} = \frac{800}{g} \left( \frac{\cos 2\theta}{\cos 15^\circ} - \frac{\sin 15^\circ \sin 2\theta}{\cos^2 15^\circ} \right)$ .

- (c) Determine the value of  $\theta$  for which  $\frac{dL}{d\theta} = 0$ . [2]
- (d) Hence determine the maximum distance the golfer can hit the ball down the slope. [1]

**END OF QUESTION PAPER**

**BLANK PAGE**

---

# OCR

Oxford Cambridge and RSA

## Copyright Information

OCR is committed to seeking permission to reproduce all third-party content that it uses in its assessment materials. OCR has attempted to identify and contact all copyright holders whose work is used in this paper. To avoid the issue of disclosure of answer-related information to candidates, all copyright acknowledgements are reproduced in the OCR Copyright Acknowledgements Booklet. This is produced for each series of examinations and is freely available to download from our public website ([www.ocr.org.uk](http://www.ocr.org.uk)) after the live examination series.

If OCR has unwittingly failed to correctly acknowledge or clear any third-party content in this assessment material, OCR will be happy to correct its mistake at the earliest possible opportunity.

For queries or further information please contact The OCR Copyright Team, The Triangle Building, Shaftesbury Road, Cambridge CB2 8EA.

OCR is part of the Cambridge Assessment Group; Cambridge Assessment is the brand name of University of Cambridge Local Examinations Syndicate (UCLES), which is itself a department of the University of Cambridge.