

OCR

Oxford Cambridge and RSA

AS Level Further Mathematics A

Y534 Discrete Mathematics

Sample Question Paper

Date – Morning/Afternoon

Time allowed: 1 hour 15 minutes

MODEL

ANSWERS

OCR supplied materials:

- Printed Answer Booklet
- Formulae AS Level Further Mathematics A

You must have:

- Printed Answer Booklet
- Formulae AS Level Further Mathematics A
- Scientific or graphical calculator



INSTRUCTIONS

- Use black ink. HB pencil may be used for graphs and diagrams only.
- Complete the boxes provided on the Printed Answer Booklet with your name, centre number and candidate number.
- Answer **all** the questions.
- **Write your answer to each question in the space provided in the Printed Answer Booklet.**
- Additional paper may be used if necessary but you must clearly show your candidate number, centre number and question number(s).
- Do **not** write in the bar codes.
- You are permitted to use a scientific or graphical calculator in this paper.
- Final answers should be given to a degree of accuracy appropriate to the context.
- The acceleration due to gravity is denoted by $g \text{ m s}^{-2}$. Unless otherwise instructed, when a numerical value is needed, use $g = 9.8$.

INFORMATION

- The total number of marks for this paper is **60**.
- The marks for each question are shown in brackets [].
- **You are reminded of the need for clear presentation in your answers.**
- The Printed Answer Booklet consists of **12** pages. The Question Paper consists of **8** pages.

- 1 Hussain wants to travel by train from Edinburgh to Southampton, leaving Edinburgh after 9 am and arriving in Southampton by 4 pm. He wants to leave Edinburgh as late as possible. Hussain rings the train company to find out about the train times. Write down a question he might ask that leads to

(A) an existence problem,

(B) an optimisation problem.

[2]

A) IS it possible to travel from Edinburgh to Southampton, leaving after 9am & still arriving by 4pm?

B) What is the latest time I can leave Edinburgh if I want to arrive in Southampton by 4pm?

2 Some of the activities that may be involved in making a cup of tea are listed below.

- A: Boil water.
- B: Put teabag in teapot, pour on boiled water and let tea brew.
- C: Get cup from cupboard.
- D: Pour tea into cup.
- E: Add milk to cup.
- F: Add sugar to cup.

Activity A must happen before activity B.

Activities B and C must happen before activity D.

Activities E and F cannot happen until after activity C.

Other than that, the activities can happen in any order.

- (i) Lisa does not take milk or sugar in her tea, so she only needs to use activities A, B, C and D. In how many different orders can activities A, B, C and D be arranged, subject to the restrictions above? [1]
- (ii) Mick takes milk but no sugar, so he needs to use activities A, B, C, D and E. Explain carefully why there are exactly nine different orders for these activities, subject to the restrictions above. [3]
- (iii) Find the number of different orders for all six activities, subject to the restrictions above. Explain your reasoning carefully. [3]

i. ABCD ACBD CABD

ii. E can go anywhere as long as it comes after C

for ABCD in that order, E can go after C or D \rightarrow 2 orders

for ACBD, E can go after B, C or D \rightarrow 3

for CABD, E can go after A, B, C, or D \rightarrow 4

$$2 + 3 + 4 = 9 \text{ total}$$

iii. F must be after C

For C in 3rd position,

ABCED }
 ABCDE } 3 positions for F each

↳ 6

For C in 2nd position:

ACEBD }
 ACBED } 4 " "

ACBDE

↳ 12

For C in 1st position:

CEABD }
 CAEBD } 5 " "

CABED

CABDE

↳ 20

$$6 + 12 + 20 = 38 \text{ total}$$

- 3 A zero-sum game is being played between two players, X and Y . The pay-off matrix for X is given below.

		Player Y	
		Strategy R	Strategy S
Player X	Strategy P	4	-2
	Strategy Q	-3	1

- (i) Find an optimal mixed strategy for player X . [5]
- (ii) Give one assumption that must be made about the behaviour of Y in order to make the mixed strategy of Player X valid. [1]

i. X plays P , probability p , & plays Q , probability $(1-p)$

if Y plays R , X can expect to win $4p - 3(1-p) =$
 $7p - 3$

if Y plays S , X can expect $-2p + (1-p) =$
 $1 - 3p$

$p=0$ gives $\min E(\text{win}) = -3$

$p=1$ gives $\min E(\text{win}) = -2$

$$7p - 3 = 1 - 3p \Rightarrow p = 0.4, \min E(\text{win}) = -0.2$$

X should randomly choose from P & Q such that
 $p(P) = 0.4, p(Q) = 0.6$

ii. assume Y isn't using a pure strategy

4 Two graphs are shown below. Each has exactly five vertices with vertex orders 2, 3, 3, 4, 4.

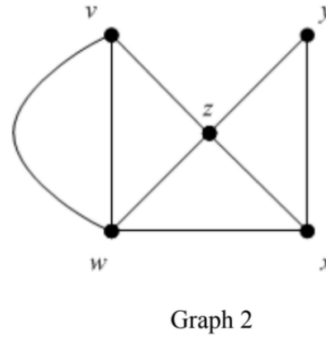
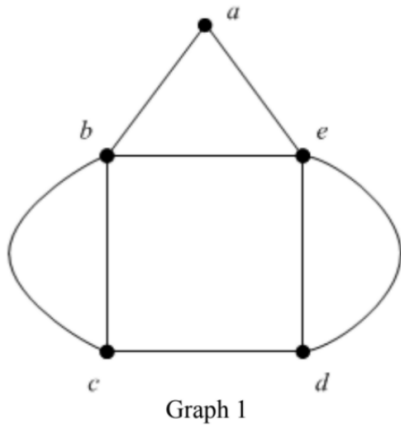

(i) Write down a semi-Eulerian route for graph 1. [1]

(ii) Explain how the vertex orders show that graph 2 is also semi-Eulerian. [1]

i. c b a e d c b e d
 ii. orders: 4, 3, 4, 2, 3
 ↳ exactly two odd nodes

(iii) By referring to specific vertices, explain how you know that these graphs are not simple. [2]

(iv) By referring to specific vertices, explain how you know that these graphs are not isomorphic. [2]

iii. graph 1: 2 arcs join b & c directly
 graph 2: " " v & w " "

iv. graph 1: vertex a is degree 2 & is next to 2 of those of degree 4, b & e. there are 2 pairs of vertices joined by 2 arcs directly.

graph 2: vertex y, degree 2, is only next to one degree 2 vertex, z. Only 1 pair joined by 2 arcs

5 There are three non-isomorphic trees on five vertices.

(i) Draw an example of each of these trees. [1]

(ii) State three properties that must be satisfied by the vertex orders of a tree on six vertices. [3]

(iii) List the five different sets of possible vertex orders for trees on six vertices. [2]

(iv) Draw an example of each type listed in part (iii). [2]

i.

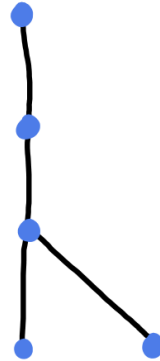
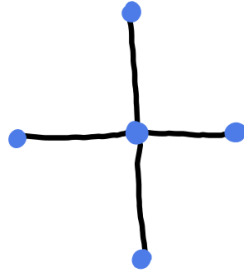
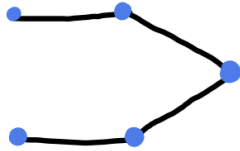

ii. 6 vertices \Rightarrow need 6 positive integer orders

5 arcs \Rightarrow sum of orders = 10 'at least 2'

tree must have ≥ 2 ends $\Rightarrow \geq 2$ vertices of order 1

iii. $\{1, 1, 1, 1, 1, 5\}$

$\{1, 1, 1, 2, 2, 3\}$

$\{1, 1, 1, 1, 3, 3\}$

$\{1, 1, 2, 2, 2, 2\}$

$\{1, 1, 1, 1, 2, 4\}$

iv.

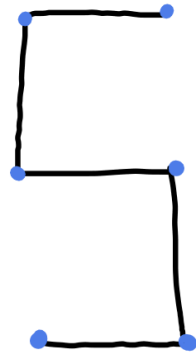
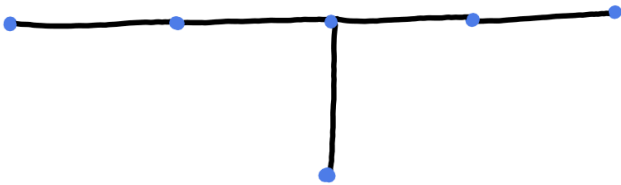
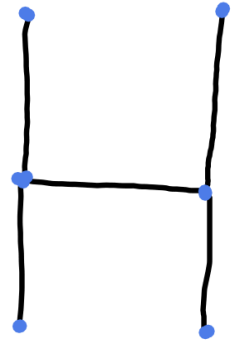
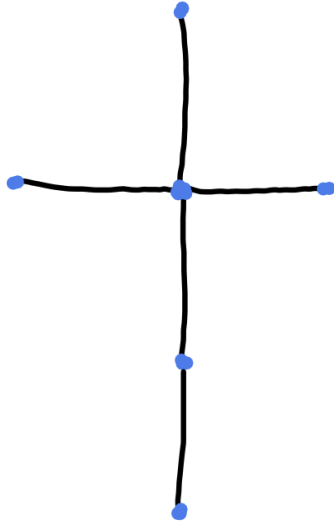
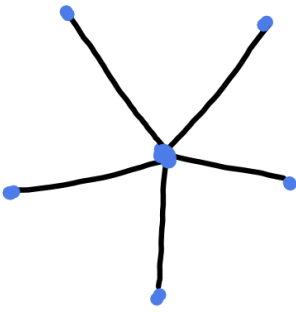

6 The following masses, in kg, are to be packed into bins.

8 5 9 7 7 9 1 3 3 8

- (i) Chloe says that first-fit decreasing gives a packing that requires 4 bins, but first-fit only requires 3 bins. Find the maximum capacity of the bins. [6]

First-fit requires one pass through the list and the time taken may be regarded as being proportional to the length of the list. Suppose that shuttle sort was used to sort the list into decreasing order.

- (ii) What can be deduced, in this case, about the order of the time complexity, $T(n)$, for first-fit decreasing? [2]

i. $8 + 5 + 9 + 7 + 7 + 9 + 1 + 3 + 3 + 8 = 60 \text{ kg}$

lower bound for capacity: $\frac{60}{3} = 20 \text{ kg}$

for capacity 20kg:

first fit:

①	8	5	7
②	9	7	1 3
③	9	3	8

first fit decreasing:

①	9	9	1
②	8	8	3
③	7	7	5
④	3		

for capacity 21 kg, first fit decreasing puts the 3 in the 1st bin & the 1 in the 2nd \Rightarrow 3 bins

statement only true for capacity ≤ 20 , but lower bound is 20kg, so bins must hold exactly 20kg

ii. let l be the length of the list

so first pass: $t \propto l$

shuttle: $t \propto l^2$

total time is sum of a quadratic function
& a linear function \Rightarrow gives a quadratic
function

so first fit decreasing: $T(n) \propto l^2$
(quadratic order)

7 A complete graph on five vertices is weighted to form a network, as given in the weighted matrix below.

	A	B	C	D	E
A	-	9	5	4	2
B	9	-	7	5	7
C	5	7	-	6	8
D	4	5	6	-	5
E	2	7	8	5	-

- (i) Apply Prim's algorithm to the copy of this weighted matrix in the Printed Answer Booklet to construct a minimum spanning tree for the five vertices.
Draw your minimum spanning tree, stating the order in which you built the tree and giving its total weight. [4]
- (ii) (a) Using only the arcs in the minimum spanning tree, which vertex should be chosen to find the smallest total of the weights of the paths from that vertex to each of the other vertices? [1]
- (b) State the minimum total for this vertex. [1]

Order of selection

① ⑤ ④ ③ ②
A B C D E

	A	B	C	D	E
A	-	9	5	4	2
B	9	-	7	⑤	7
C	⑤	7	-	6	8
D	④	5	6	-	5
E	②	7	8	5	-

Weight = $2 + 4 + 5 + 5 = 16$

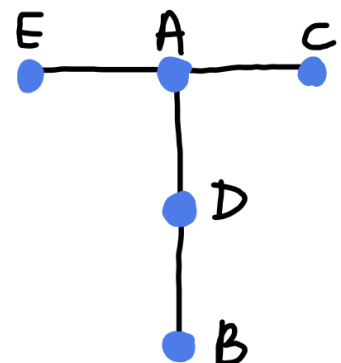

ii. a) vertex A

b) $2 + 5 + 4 + (4 + 5) = 20$

A to B goes via
D: AD(4) → DB(5)

- (iii) Show that the total number of comparisons needed to find a minimum spanning tree for a 5×5 matrix is 16. [3]
- (iv) If a computer takes 4 seconds to find a minimum spanning tree for a network with 100 vertices, how long would it take to find a minimum spanning tree for a network with 500 vertices? [2]

iii. from first vertex, 4 possible arcs to make

now 2 vertices available with 3 possibilities each

then 3 with 2 each

finally, 4 with 1 each

comparison requires considering 2 vertices \Rightarrow subtract 1
from number of potential arcs

$$(1 \times 4) - 1 + (2 \times 3) - 1 + (3 \times 2) - 1 + (4 \times 1) - 1 = 3 + 5 + 5 + 3$$

$$= 16$$

iv. Prim's has cubic order

$$t \propto n^3$$

$$4 = k \times 100^3$$

$$\Rightarrow t_{500} = 4 \times \left(\frac{500}{100} \right)^3$$

$$= 500 \text{ s}$$

- 8 A sweet shop sells three different types of boxes of chocolate truffles. The cost of each type of box and the number of truffles of each variety in each type of box are given in the table below.

Type	Cost (£)	Milk chocolate	Plain chocolate	White chocolate	Nutty chocolate
Assorted	2.00	5	5	5	5
No Nuts	1.00	5	8	7	0
Speciality	2.50	5	4	9	2

Narendra wants to buy some boxes of truffles so that in total he has at least 20 milk chocolate, 10 plain chocolate, 16 white chocolate and 12 nutty chocolate truffles.

- (i) Explain why Narendra needs to buy at least four boxes of truffles. [1]

each type contains 5 milk chocolate. need at least 20
 $\Rightarrow 4 \times 5 = 20$

- (ii) Narendra decides that he will buy exactly four boxes. Determine the minimum number of Assorted boxes that Narendra must buy. [1]

Need 12 nutty chocolate. Assorted contains 5
 \Rightarrow need at least 2 Assorted

- (iii) For your answer in part (ii),

- list all the feasible solutions and
- find the cheapest solution.

[3]

type	type			cost
	assorted	no nuts	speciality	£
	4	0	0	8.00
	3	1	0	7.00
	3	0	1	8.50
	2	1	1	7.50
	2	0	2	9.00

Cheapest: 3 Assorted, 1x No Nuts

Narendra finds that the sweet shop has sold out of Assorted boxes, but he then spots that it also sells small boxes of milk chocolate truffles and small boxes of nutty chocolate truffles. Each small box contains 4 truffles (all of one variety) and costs £0.50.

He decides to buy x boxes of No Nuts and y boxes of Speciality, where $x + y < 4$, so that he has at least 10 plain chocolate and 16 white chocolate truffles. He will then buy as many small boxes as he needs to give a total of at least 20 milk chocolate and 12 nutty chocolate truffles.

- (iv) (a) Set up constraints on the values of x and y . [2]
 (b) Represent the feasible region graphically. [2]
 (c) Hence determine the cheapest cost for Narendra. [3]

END OF QUESTION PAPER

iv. a) Plain: $8x + 4y \geq 10$

White: $7x + 9y \geq 16$

$x \geq 0, y \geq 0, x \& y$ are integers

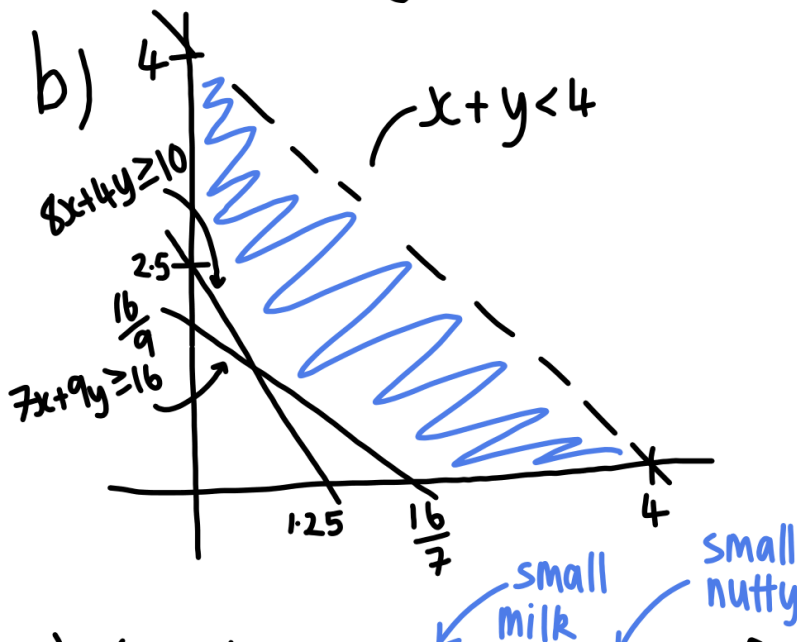

c) $(0, 3) + 2 \text{ sm} + 2 \text{ sn} \Rightarrow \text{£}9.50$

$(1, 2) + 2 \text{ sm} + 2 \text{ sn} \Rightarrow \text{£}8.00$

$(2, 1) + 2 \text{ sm} + 2 \text{ sn} \Rightarrow \text{£}7.00$

Check all integer values about optimum (0.59, 1.32)

$$(3, 0) + 2sm + 3sn \Rightarrow \text{£}5.50$$

$$(1, 1) + 3sm + 3sn \Rightarrow \text{£}6.50$$

Cheapest: £5.50