

UNIVERSITY OF CAMBRIDGE INTERNATIONAL EXAMINATIONS
General Certificate of Education Advanced Level

MATHEMATICS

9709/05

Paper 5 Mechanics 2 (M2)

May/June 2006

1 hour 15 minutes

Additional Materials: Answer Booklet/Paper
Graph paper
List of Formulae (MF9)

READ THESE INSTRUCTIONS FIRST

If you have been given an Answer Booklet, follow the instructions on the front cover of the Booklet.
Write your Centre number, candidate number and name on all the work you hand in.
Write in dark blue or black pen on both sides of the paper.
You may use a soft pencil for any diagrams or graphs.
Do not use staples, paper clips, highlighters, glue or correction fluid.

Answer **all** the questions.

Give non-exact numerical answers correct to 3 significant figures, or 1 decimal place in the case of angles in degrees, unless a different level of accuracy is specified in the question.

Where a numerical value for the acceleration due to gravity is needed, use 10 m s^{-2} .

The use of an electronic calculator is expected, where appropriate.

You are reminded of the need for clear presentation in your answers.

The number of marks is given in brackets [] at the end of each question or part question.

The total number of marks for this paper is 50.

Questions carrying smaller numbers of marks are printed earlier in the paper, and questions carrying larger numbers of marks later in the paper.

At the end of the examination, fasten all your work securely together.

This document consists of **4** printed pages.



2

1

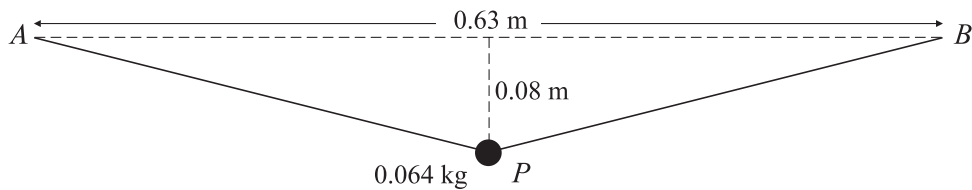

A light elastic string has natural length 0.6 m and modulus of elasticity λ N. The ends of the string are attached to fixed points A and B , which are at the same horizontal level and 0.63 m apart. A particle P of mass 0.064 kg is attached to the mid-point of the string and hangs in equilibrium at a point 0.08 m below AB (see diagram). Find

(i) the tension in the string, [3]

(ii) the value of λ . [2]

2 A uniform solid cone has height 38 cm.

(i) Write down the distance of the centre of mass of the cone from its base. [1]

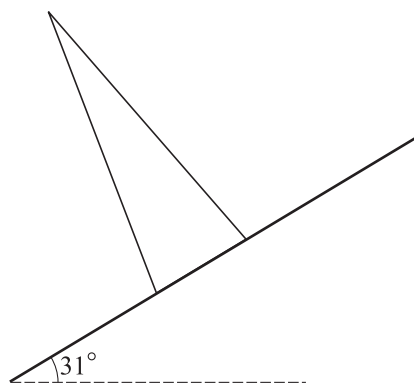

The cone is placed with its axis vertical on a rough horizontal plane. The plane is slowly tilted, and the cone remains in equilibrium until the angle of inclination of the plane reaches 31° (see diagram), when the cone topples.

(ii) Find the radius of the cone. [2]

(iii) Show that $\mu \geq 0.601$, correct to 3 significant figures, where μ is the coefficient of friction between the cone and the plane. [2]

3

3

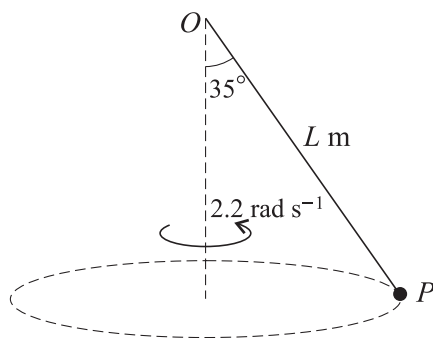

A particle P of mass m kg is attached to one end of a light inextensible string of length L m. The other end of the string is attached to a fixed point O . The particle P moves with constant speed in a horizontal circle, with the string taut and inclined at 35° to the vertical. OP rotates with angular speed 2.2 rad s^{-1} about the vertical axis through O (see diagram). Find

(i) the value of L , [4]

(ii) the speed of P in m s^{-1} . [2]

4 An object of mass 0.4 kg is projected vertically upwards from the ground, with an initial speed of 16 m s^{-1} . A resisting force of magnitude $0.1v$ newtons acts on the object during its ascent, where $v \text{ m s}^{-1}$ is the speed of the object at time t s after it starts to move.

(i) Show that $\frac{dv}{dt} = -0.25(v + 40)$. [2]

(ii) Find the value of t at the instant that the object reaches its maximum height. [5]

5

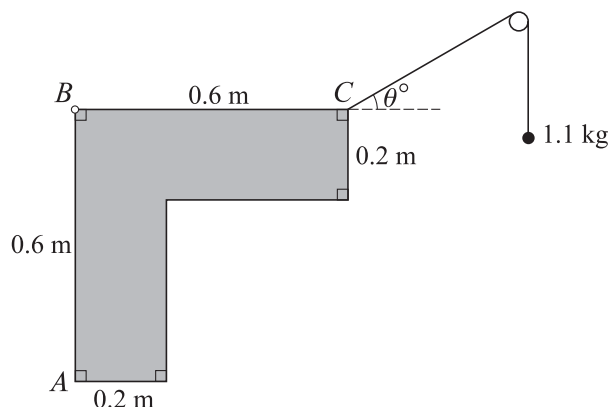

A uniform lamina of weight 15 N has dimensions as shown in the diagram.

(i) Show that the distance of the centre of mass of the lamina from AB is 0.22 m . [4]

The lamina is freely hinged at B to a fixed point. One end of a light inextensible string is attached to the lamina at C . The string passes over a fixed smooth pulley and a particle of mass 1.1 kg is attached to the other end of the string. The lamina is in equilibrium with BC horizontal. The string is taut and makes an angle of θ° with the horizontal at C , and the particle hangs freely below the pulley (see diagram).

(ii) Find the value of θ . [3]

- 6** A light elastic string has natural length 2 m and modulus of elasticity 0.8 N. One end of the string is attached to a fixed point O of a rough plane which is inclined at an angle α to the horizontal, where $\sin \alpha = \frac{12}{13}$. A particle P of mass 0.052 kg is attached to the other end of the string. The coefficient of friction between the particle and the plane is 0.4. P is released from rest at O .
- (i) When P has moved d metres down the plane from O , where $d > 2$, find expressions in terms of d for
- (a) the loss in gravitational potential energy of P , [2]
- (b) the gain in elastic potential energy of the string, [2]
- (c) the work done by the frictional force acting on P . [2]
- (ii) Show that $d^2 - 6d + 4 = 0$ when P is at its lowest point, and hence find the value of d in this case. [3]
- 7** A stone is projected from a point O on horizontal ground with speed $V \text{ m s}^{-1}$ at an angle θ above the horizontal, where $\sin \theta = \frac{3}{5}$. The stone is at its highest point when it has travelled a horizontal distance of 19.2 m.
- (i) Find the value of V . [3]
- After passing through its highest point the stone strikes a vertical wall at a point 4 m above the ground.
- (ii) Find the horizontal distance between O and the wall. [4]
- At the instant when the stone hits the wall the horizontal component of the stone's velocity is halved in magnitude and reversed in direction. The vertical component of the stone's velocity does not change as a result of the stone hitting the wall.
- (iii) Find the distance from the wall of the point where the stone reaches the ground. [4]