

1. A beam AB has length 6 m and weight 200 N. The beam rests in a horizontal position on two supports at the points C and D , where $AC = 1$ m and $DB = 1$ m. Two children, Sophie and Tom, each of weight 500 N, stand on the beam with Sophie standing twice as far from the end B as Tom. The beam remains horizontal and in equilibrium and the magnitude of the reaction at D is three times the magnitude of the reaction at C . By modelling the beam as a uniform rod and the two children as particles, find how far Tom is standing from the end B .

(Total 7 marks)

2.

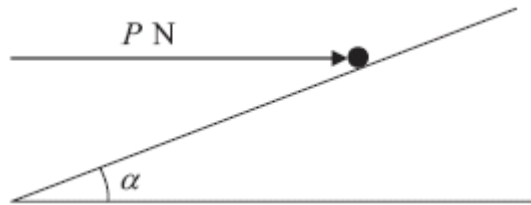

A particle of mass 0.4 kg is held at rest on a fixed rough plane by a horizontal force of magnitude P newtons. The force acts in the vertical plane containing the line of greatest slope of the inclined plane which passes through the particle. The plane is inclined to the horizontal at an angle α , where $\tan \alpha = \frac{3}{4}$, as shown in the diagram above.

The coefficient of friction between the particle and the plane is $\frac{1}{3}$.

Given that the particle is on the point of sliding up the plane, find

- (a) the magnitude of the normal reaction between the particle and the plane,

(5)

- (b) the value of P .

(5)

(Total 10 marks)

3.

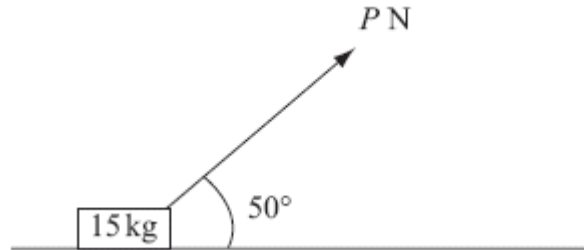

A small box of mass 15 kg rests on a rough horizontal plane. The coefficient of friction between the box and the plane is 0.2. A force of magnitude P newtons is applied to the box at 50° to the horizontal, as shown in the diagram above. The box is on the point of sliding along the plane.

Find the value of P , giving your answer to 2 significant figures.

(Total 9 marks)

4.

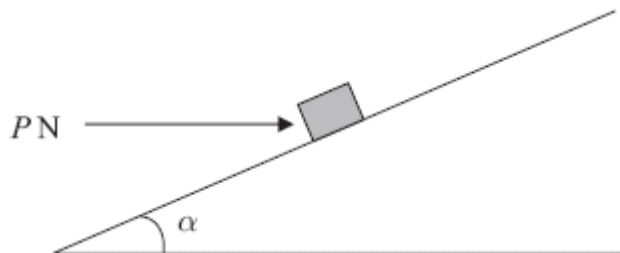

A small package of mass 1.1 kg is held in equilibrium on a rough plane by a horizontal force. The plane is inclined at an angle α to the horizontal, where $\tan \alpha = \frac{3}{4}$. The force acts in a vertical plane containing a line of greatest slope of the plane and has magnitude P newtons, as shown in the diagram above.

The coefficient of friction between the package and the plane is 0.5 and the package is modelled as a particle. The package is in equilibrium and on the point of slipping down the plane.

- (a) Draw, on the diagram above, all the forces acting on the package, showing their directions clearly.

(2)

- (b) (i) Find the magnitude of the normal reaction between the package and the plane.
(ii) Find the value of P .

(11)

(Total 13 marks)

5. Two forces, $(4\mathbf{i} - 5\mathbf{j})$ N and $(p\mathbf{i} + q\mathbf{j})$ N, act on a particle P of mass m kg. The resultant of the two forces is \mathbf{R} . Given that \mathbf{R} acts in a direction which is parallel to the vector $(\mathbf{i} - 2\mathbf{j})$,

- (a) find the angle between \mathbf{R} and the vector \mathbf{j} ,

(3)

- (b) show that $2p + q + 3 = 0$.

(4)

Given also that $q = 1$ and that P moves with an acceleration of magnitude $8\sqrt{5} \text{ m s}^{-2}$,

- (c) find the value of m .

(7)

(Total 14 marks)

6.

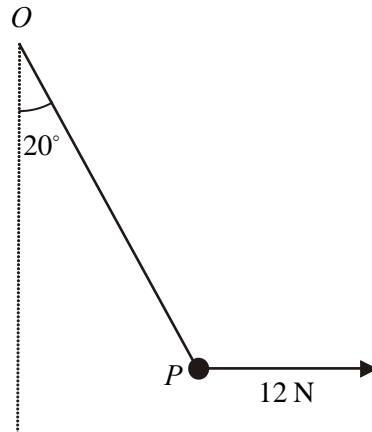

A particle P is attached to one end of a light inextensible string. The other end of the string is attached to a fixed point O . A horizontal force of magnitude 12 N is applied to P . The particle P is in equilibrium with the string taut and OP making an angle of 20° with the downward vertical, as shown in the diagram above.

Find

- (a) the tension in the string,

(3)

- (b) the weight of P .

(4)

(Total 7 marks)

7.

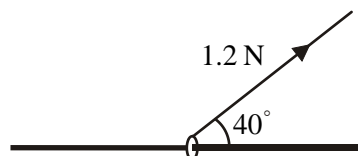

A small ring of mass 0.25 kg is threaded on a fixed rough horizontal rod. The ring is pulled upwards by a light string which makes an angle 40° with the horizontal, as shown in the diagram above. The string and the rod are in the same vertical plane. The tension in the string is 1.2 N and the coefficient of friction between the ring and the rod is μ . Given that the ring is in limiting equilibrium, find

- (a) the normal reaction between the ring and the rod,

(4)

- (b) the value of μ .

(6)
(Total 10 marks)

8.

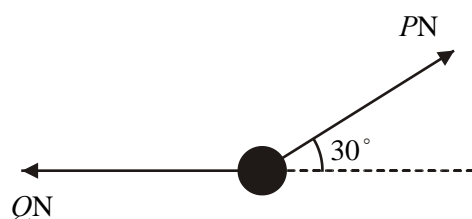

A particle of weight 24 N is held in equilibrium by two light inextensible strings. One string is horizontal. The other string is inclined at an angle of 30° to the horizontal, as shown in the diagram above. The tension in the horizontal string is Q newtons and the tension in the other string is P newtons. Find

- (a) the value of P ,

(3)

- (b) the value of Q .

(3)
(Total 6 marks)

9.

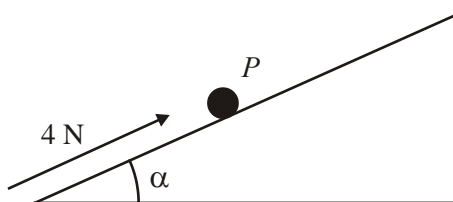

A particle P of mass 0.5 kg is on a rough plane inclined at an angle α to the horizontal, where $\tan \alpha = \frac{3}{4}$. The particle is held at rest on the plane by the action of a force of magnitude 4 N acting up the plane in a direction parallel to a line of greatest slope of the plane, as shown in the figure above. The particle is on the point of slipping up the plane.

- (a) Find the coefficient of friction between P and the plane.

(7)

The force of magnitude 4 N is removed.

- (b) Find the acceleration of P down the plane.

(4)

(Total 11 marks)

10.

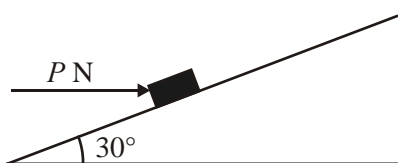

A parcel of weight 10N lies on a rough plane inclined at an angle of 30° to the horizontal. A horizontal force of magnitude P newtons acts on the parcel, as shown in the figure above. The parcel is in equilibrium and on the point of slipping up the plane. The normal reaction of the plane on the parcel is 18N. The coefficient of friction between the parcel and the plane is μ . Find

- (a) the value of P ,

(4)

- (b) the value of μ .

(5)

The horizontal force is removed.

- (c) Determine whether or not the parcel moves.

(5)

(Total 14 marks)

11.

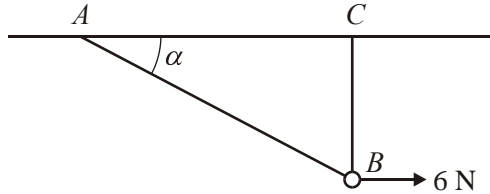

A smooth bead B is threaded on a light inextensible string. The ends of the string are attached to two fixed points A and C on the same horizontal level. The bead is held in equilibrium by a horizontal force of magnitude 6 N acting parallel to AC . The bead B is vertically below C and $\angle BAC = \alpha$, as shown in the diagram. Given that $\tan \alpha = \frac{3}{4}$, find

(a) the tension in the string,

(3)

(b) the weight of the bead.

(4)

(Total 7 marks)

12.

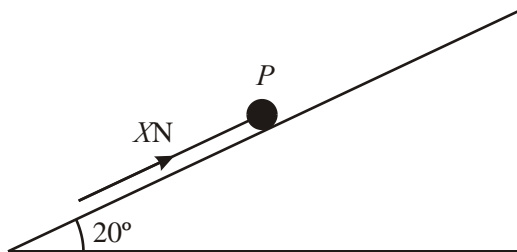

A particle P of mass 2.5 kg rests in equilibrium on a rough plane under the action of a force of magnitude X newtons acting up a line of greatest slope of the plane, as shown in the diagram above. The plane is inclined at 20° to the horizontal. The coefficient of friction between P and the plane is 0.4 . The particle is in limiting equilibrium and is on the point of moving up the plane. Calculate

(a) the normal reaction of the plane on P ,

(2)

(b) the value of X .

(4)

The force of magnitude X newtons is now removed.

- (c) Show that P remains in equilibrium on the plane.

(4)

(Total 10 marks)

13.

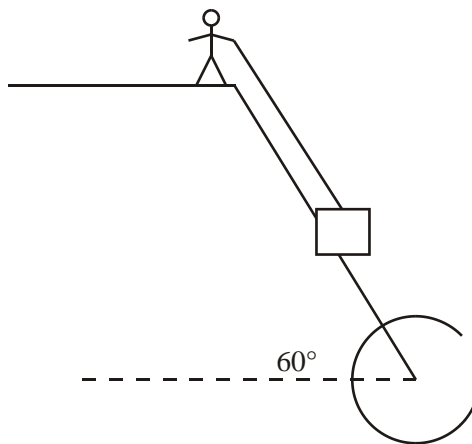

A heavy package is held in equilibrium on a slope by a rope. The package is attached to one end of the rope, the other end being held by a man standing at the top of the slope. The package is modelled as a particle of mass 20 kg. The slope is modelled as a rough plane inclined at 60° to the horizontal and the rope as a light inextensible string. The string is assumed to be parallel to a line of greatest slope of the plane, as shown in the diagram above. At the contact between the package and the slope, the coefficient of friction is 0.4.

- (a) Find the minimum tension in the rope for the package to stay in equilibrium on the slope.

(8)

The man now pulls the package up the slope. Given that the package moves at constant speed,

- (b) find the tension in the rope.

(4)

- (c) State how you have used, in your answer to part (b), the fact that the package moves

- (i) up the slope,

(ii) at constant speed.

(2)
(Total 14 marks)

14.

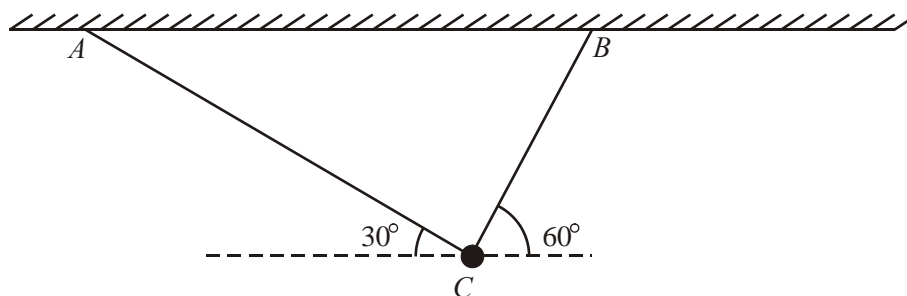

A particle of weight W newtons is attached at C to the ends of two light inextensible strings AC and BC . The other ends of the strings are attached to two fixed points A and B on a horizontal ceiling. The particle hangs in equilibrium with AC and BC inclined to the horizontal at 30° and 60° respectively, as shown in the diagram above. Given the tension in AC is 50 N , calculate

(a) the tension in BC , to 3 significant figures,

(3)

(b) the value of W .

(3)
(Total 6 marks)

15.

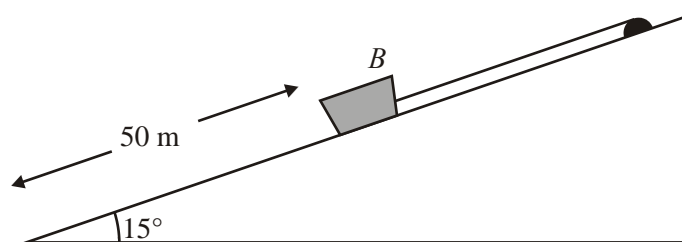

The diagram above shows a boat B of mass 400 kg held at rest on a slipway by a rope. The boat is modelled as a particle and the slipway as a rough plane inclined at 15° to the horizontal. The coefficient of friction between B and the slipway is 0.2 . The rope is modelled as a light, inextensible string, parallel to a line of greatest slope of the plane. The boat is in equilibrium and on the point of sliding down the slipway.

- (a) Calculate the tension in the rope.

(6)

The boat is 50 m from the bottom of the slipway. The rope is detached from the boat and the boat slides down the slipway.

- (b) Calculate the time taken for the boat to slide to the bottom of the slipway.

(6)

(Total 12 marks)

16.

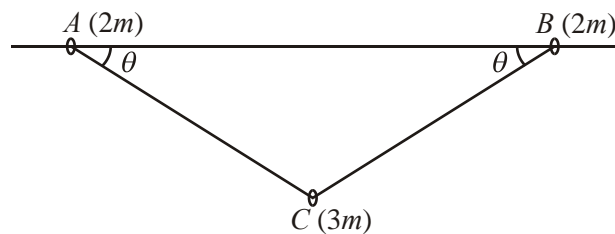

Two small rings, A and B , each of mass $2m$, are threaded on a rough horizontal pole. The coefficient of friction between each ring and the pole is μ . The rings are attached to the ends of a light inextensible string. A smooth ring C , of mass $3m$, is threaded on the string and hangs in equilibrium below the pole. The rings A and B are in limiting equilibrium on the pole, with $\angle BAC = \angle ABC = \theta$, where $\tan \theta = \frac{3}{4}$, as shown in the diagram above.

- (a) Show that the tension in the string is $\frac{5}{2} mg$.

(3)

- (b) Find the value of μ .

(7)

(Total 10 marks)

17.

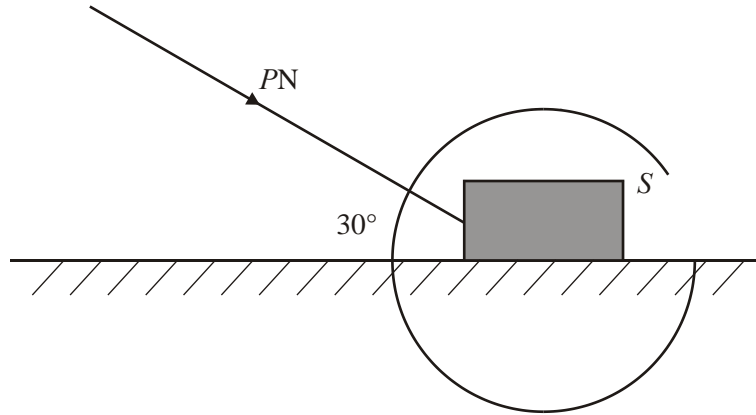

A heavy suitcase S of mass 50 kg is moving along a horizontal floor under the action of a force of magnitude P newtons. The force acts at 30° to the floor, as shown in the diagram above, and S moves in a straight line at constant speed. The suitcase is modelled as a particle and the floor as a rough horizontal plane. The coefficient of friction between S and the floor is $\frac{3}{5}$.

Calculate the value of P .

(Total 9 marks)

18.

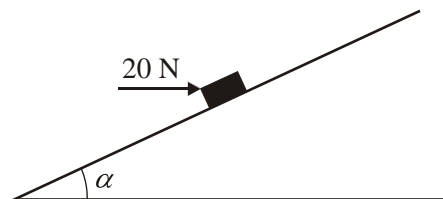

A parcel of mass 5 kg lies on a rough plane inclined at an angle α to the horizontal, where $\tan \alpha = \frac{3}{4}$. The parcel is held in equilibrium by the action of a horizontal force of magnitude 20 N, as shown in the diagram above. The force acts in a vertical plane through a line of greatest slope of the plane. The parcel is on the point of sliding down the plane. Find the coefficient of friction between the parcel and the plane.

(Total 8 marks)

19.

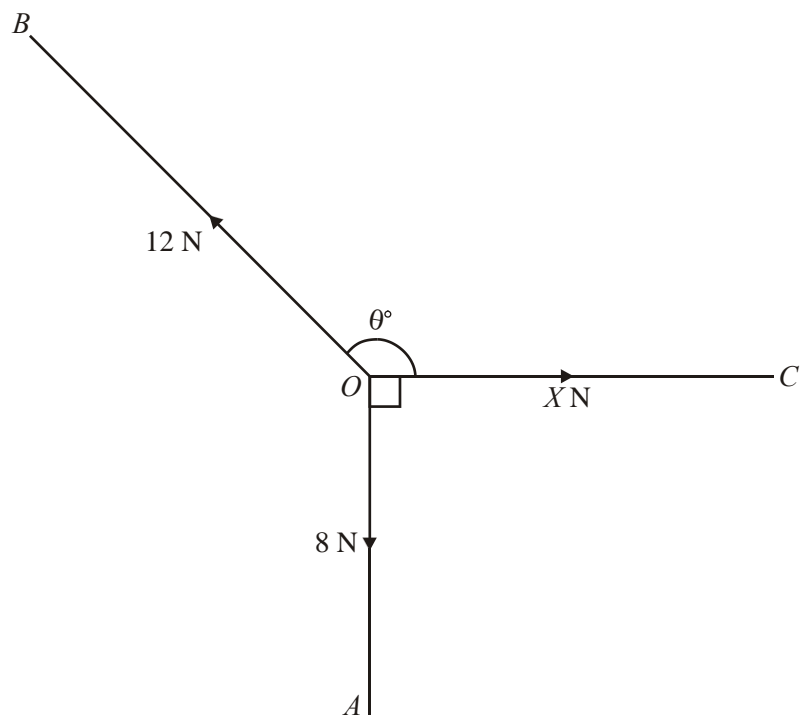

In the diagram above, $\angle AOC = 90^\circ$ and $\angle BOC = \theta^\circ$. A particle at O is in equilibrium under the action of three coplanar forces. The three forces have magnitudes 8 N, 12 N and X N and act along OA , OB and OC respectively. Calculate

(a) the value, to one decimal place, of θ ,

(3)

(b) the value, to 2 decimal places, of X .

(3)

(Total 6 marks)

20.

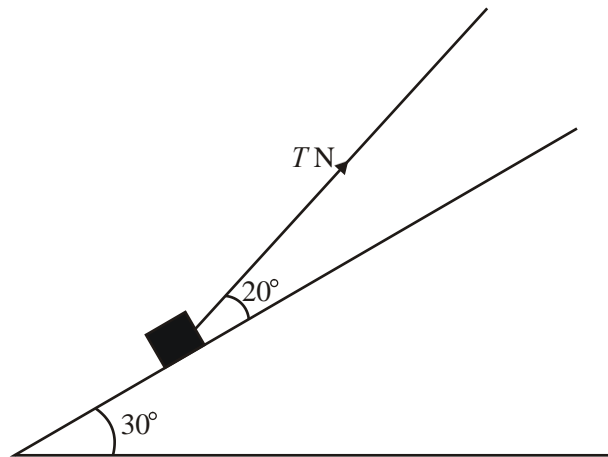

A box of mass 1.5 kg is placed on a plane which is inclined at an angle of 30° to the horizontal. The coefficient of friction between the box and plane is $\frac{1}{3}$. The box is kept in equilibrium by a light string which lies in a vertical plane containing a line of greatest slope of the plane. The string makes an angle of 20° with the plane, as shown in the diagram above. The box is in limiting equilibrium and is about to move up the plane. The tension in the string is T newtons. The box is modelled as a particle.

Find the value of T .

(Total 10 marks)

21.

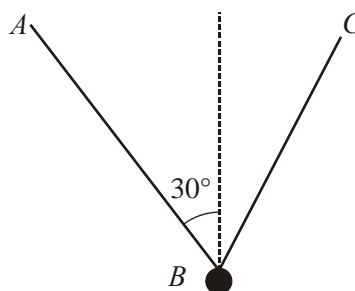

A particle has mass 2 kg . It is attached at B to the ends of two light inextensible strings AB and BC . When the particle hangs in equilibrium, AB makes an angle of 30° with the vertical, as shown above. The magnitude of the tension in BC is twice the magnitude of the tension in AB .

- (a) Find, in degrees to one decimal place, the size of the angle that BC makes with the vertical.

(4)

- (b) Hence find, to 3 significant figures, the magnitude of the tension in AB .

(4)

(Total 8 marks)

1.

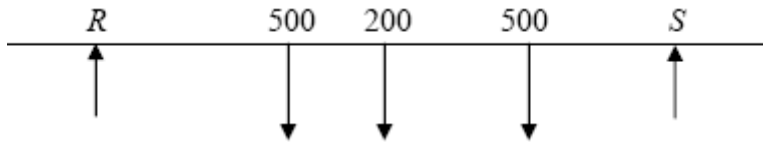

$M(B)$,

$$500x + 500 \cdot 2x + 200 \cdot 3 = Rx5 + Sx1$$

(or any valid moments equation)

A1 A1

$$(\downarrow) R + S = 500 + 500 + 200 = 1200 \text{ (or a moments equation)}$$

A1

solving for x ; $x = 1.2 \text{ m}$

A1 cso

[7]

2. (a) $F = \frac{1}{3}R$

B1

$$(\uparrow) R \cos \alpha - F \sin \alpha = 0.4g$$

A1

$$R = \frac{2}{3}g = 6.53 \text{ or } 6.5$$

A1

5

(b) $(\rightarrow) P - F \cos \alpha - R \sin \alpha = 0$

A2

$$P = \frac{26}{45}g = 5.66 \text{ or } 5.7$$

A1

5

[10]

3. $F = P \cos 50^\circ$

A1

$F = 0.2R$ seen or implied.

B1

$$P \sin 50^\circ + R = 15g$$

A1 A1

Eliminating R ; Solving for P ;

DM1;D

$$P = 37 \text{ (2 SF)}$$

A1

[9]

4. (a)

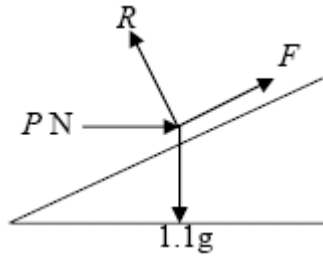

B2
-1 e.e.o.o.
(labels not needed) 2

(b)

$$F = \frac{1}{2}R$$

$$(\uparrow), R \cos \alpha + F \sin \alpha = mg$$

B1

$$R = \frac{1.1g}{(\cos \alpha + \frac{1}{2} \sin \alpha)} = 9.8 \text{ N}$$

A2

$$(\rightarrow), P + \frac{1}{2}R \cos \alpha = R \sin \alpha$$

A1

6

A2

$$P = R(\sin \alpha - \frac{1}{2} \cos \alpha)$$

$$= 1.96$$

A1

5

[13]

5. (a)



$$\tan \theta = \frac{2}{1} \Rightarrow \theta = 63.4^\circ$$

A1

angle is 153.4°

A1

3

(b)

$$(4 + p)\mathbf{i} + (q - 5)\mathbf{j}$$

B1

$$(q - 5) = -2(4 + p)$$

A1

$$2p + q + 3 = 0^*$$

A1

4

- (c) $q=1 \Rightarrow p=-2$ B1
 $\Rightarrow \mathbf{R} = 2\mathbf{i} - 4\mathbf{j}$
 $\Rightarrow |\mathbf{R}| = \sqrt{2^2 + (-4)^2} = \sqrt{20}$ A1 f.t.
 $\sqrt{20} = m8\sqrt{5}$ A1 f.t.
 $\Rightarrow m = \frac{1}{4}$ A1 cao 7

[14]

6.

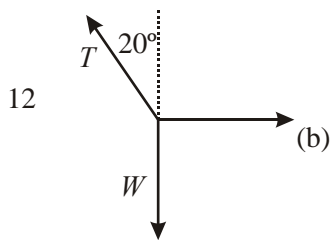

- (a) $\rightarrow T \sin 20^\circ = 12$ M1A1
 $T \approx 35.1 \text{ (N) awrt } 35$ A1 3
- (b) $\uparrow W = T \cos 20^\circ$ M1A1
 $\approx 33.0 \text{ (N)}$ awrt 33 DM1A1 4

[7]

7. (a)

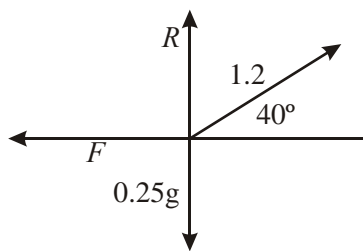

- $\uparrow \pm R + 1.2 \sin 40^\circ = 0.25g$
 Solving to $R = 1.7 \text{ (N)}$ M1A1
accept 1.68 DM1A1 4
- (b) $\rightarrow F = 1.2 \cos 40^\circ (\approx 0.919)$ M1A1
 Use of $F = \mu R$ B1
 $1.2 \cos 40^\circ = \mu R$ ft their R DM1A1ft
 $\mu \approx 0.55$ accept 0.548 A1cao 6

[10]

8. (a) $P \sin 30^\circ = 24$ M1A1
 $P = 48$ A1 3
- (b) $Q = P \cos 30^\circ$ M1A1
 ≈ 41.6 A1 3
 accept $24\sqrt{3}$, awrt 42

[6]

9. (a)

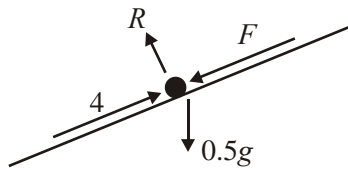

- $R = 0.5g \cos \alpha = 0.4g$ A1
 $4 = F + 0.5g \sin \alpha$ A1
 $F = \mu R$ used
 $4 = 0.4g\mu + 0.3g$
 $\Rightarrow \mu \approx 0.27(0)$ A1 7

1st two s require correct number of the correct terms, with valid attempt to resolve the correct relevant term (valid 'resolve' = $x \sin / \cos$).

4th (dept) for forming equn in μ , + numbers only

(b)

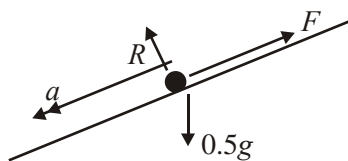

- $0.5a = 0.3g - 0.27 \times 0.4g$ A2,1,0ft
 $\Rightarrow a \approx (+) 3.76 \text{ m s}^{-2}$ (or 3.8) A1 4

In first equn, allow their R or F in the equation for full marks.

A marks: f.t. on their R, F etc. Deduct one A mark (up to 2) for each wrong term.

[11]

10.

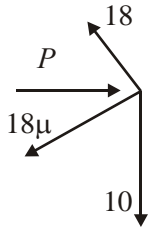

- (a) R(perp to plane):
 $P \sin 30 + 10 \cos 30 = 18$ A1
 Solve: $P \approx \underline{18.7 \text{ N}}$ A1 4
- (b) R(// plane):
 $P \cos 30 = 10 \sin 30 + F$ A1
 $F = 18\mu$ used
 Sub and solve: $\mu = \underline{0.621 \text{ or } 0.62}$ A1 5
- (c) Normal reaction now = $10 \cos 30$ A1
 Component of weight down plane = $10 \sin 30$ (= 5 N) (seen) B1
 $F_{\max} = \mu R_{\text{new}} \approx 5.37 \text{ N}$ (AWRT 5.4)
 $5.37 > 5 \Rightarrow$ does not slide A1 cso 5

[14]

11.

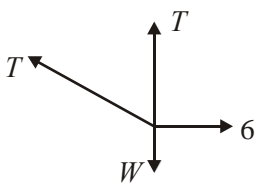

- (a) R(\rightarrow) $T \cos \alpha = 6$ A1
 $\rightarrow T = \underline{7.5 \text{ N}}$ A1 3
- (b) R(\uparrow) $T + T \sin \alpha = W$ M1A1
↓
 Using same T 's and solving
 $\rightarrow W = \underline{12 \text{ N}}$ A1 4

[7]

12.

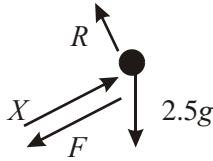

(a) $R = 2.5g \cos 20$
 $\approx \underline{23.0 \text{ or } 23 \text{ N}}$

A1 2

(b) $X = 0.4 \times 23.0 + 2.5g \sin 20$
 $\approx \underline{17.6 \text{ or } 18 \text{ N}}$

A2,1,0ft

A1 4

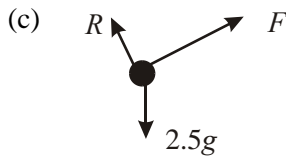

In equilb. $F = 2.5g \sin 20 \approx 8.38 \text{ or } 8.4 \text{ N}$

B1

$\mu R = 0.4 \times 2.5g \cos 20 \approx 9.21 \text{ or } 9.2 \text{ N}$

B1

$8.4 < 9.2$ (using 'F < μR ' **not** $F = \mu R$)

Since $F < \mu R$ remains in equilibrium (cso)

A1 4

[10]

13. (a)

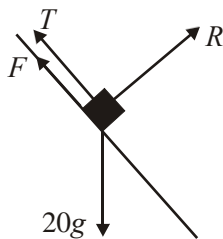

R(perp. to slope): $R = 20g \cos 60 (= 10g = 98 \text{ N})$

A1

$F = 0.4R$ (used)

B1

R(parallel to slope): $T + F = 20g \cos 30$

A2, 1, 0

$T = 10\sqrt{3}g - 4g \approx \underline{131 \text{ or } 130 \text{ N}}$

↓

A1

8

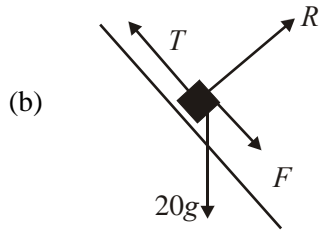

$$R = 10g \text{ as before}$$

$$T - 0.4R = 20g \cos 30$$

$$T = 10\sqrt{3}g + 4g \approx \underline{209 \text{ or } 210 \text{ N}}$$

B1 ft
A1
A1 4

- (c) (i) Friction acts down slope (and has magnitude $0.4R$)
 (ii) Net force on package = 0 (or equivalent), or 'no acceleration'

B1
B1 2

[14]

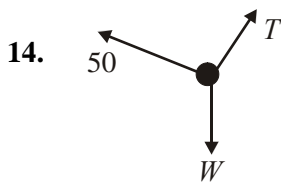

(a) R (\rightarrow): $T \cos 60 = 50 \cos 30$
 $T = \underline{86.6 \text{ N}}$

A1
A1 3

(b) R (\uparrow): $W = 50 \sin 30 + T \cos 30$
 $= \underline{100 \text{ N}}$
 or R (\perp to BC): $W \cos 60 = 50$
 $W = \underline{100 \text{ N}}$

A1
A1 3
A1
A1 3

[6]

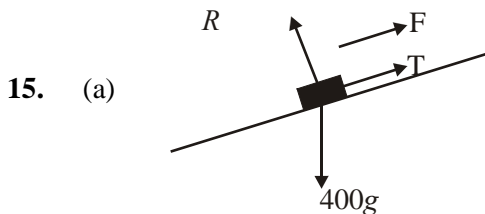

$$R = 400g \cos 15^\circ (\approx 3786 \text{ N})$$

$$F = 0.2R \text{ used}$$

$$T + 0.2R = 400g \sin 15^\circ$$

$$T \approx \underline{257 \text{ or } 260 \text{ N}}$$

B1
B1
A1
 \downarrow
A1 6

- (b) $400g \sin 15^\circ - 0.2 \times 400g \cos 15^\circ = 400a$ A1
 $a = 0.643(\dots)$ A1
 $50 = \frac{1}{2} \times 0.643 \times t^2$ A1f.t.
 $t = \underline{12.5 \text{ or } 12 \text{ s}}$ A1 6

[12]

16. (a)

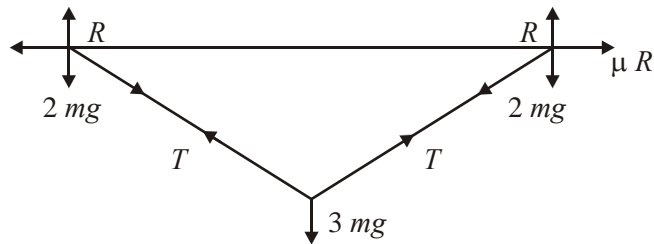

- $R \uparrow$ for C; $2T \sin \theta = 3mg$ A1
 $\sin \theta = \frac{3}{5} \Rightarrow T = \frac{5}{2}mg (*)$ A1 3

- (b) $R \uparrow$ for A or B: $R = 2mg + T \sin \theta$ A1
 $= 2mg + \frac{5}{2}mg \cdot \frac{3}{5} = \frac{7}{2}mg$ ↓

- $R \rightarrow$ for A or B: $T \cos \theta = \mu R$ A1
↓↓

- Solve to get μ as number: $\frac{5}{2}mg \cdot \frac{4}{5} = \mu \cdot \frac{7}{2}mg \Rightarrow \mu = \frac{4}{7}$ A1 7
 (Accept 0.57 awrt)

[10]

17.

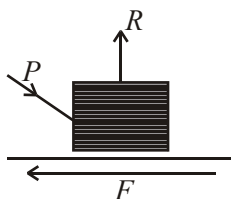

$$R \uparrow: R = 50g + P \sin 30^\circ$$

A2,1,0

$$R \rightarrow: F = P \cos 30^\circ$$

A1

$$F = \frac{3}{5} R \text{ used}$$

B1

$$P \cos 30^\circ = \frac{3}{5} (50g + P \sin 30^\circ) \text{ Elim } F, R$$

$$\text{Solve } P = 520 \text{ or } 519 \text{ N}$$

A1

3rd dependent on both 1st two s

4th dependent on 3rd

[9]

18.

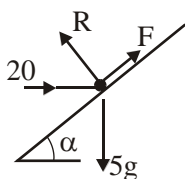

$$R(\searrow): R = 5g \cos \alpha + 20 \sin \alpha$$

A1

$$R(\nearrow): F + 20 \cos \alpha = 5g \sin \alpha$$

A1

$$\text{Using } \cos \alpha = \frac{4}{5} \text{ or } \sin \alpha = \frac{3}{5}$$

B1

$$[\Rightarrow R = 51.2 \text{ N}; F = 13.4 \text{ N}]$$

$$\text{Using } F = \mu R$$

$$\text{Solving: } \mu = 0.262 \text{ (accept 0.26)}$$

A1

8

[8]

19. (a)

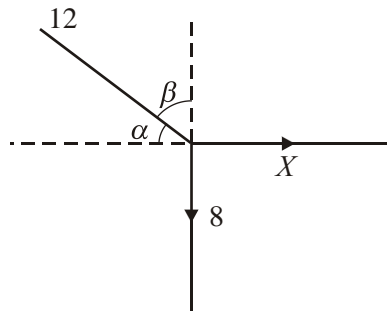

$$R(\uparrow) 8 = 12 \cos \beta \text{ or } 12 \sin \alpha$$

$$\Rightarrow \beta = 41.8^\circ \text{ or } \alpha = 48.2^\circ$$

$$\Rightarrow \theta = 138.2^\circ$$

A1
A1 3

(b) $R(\rightarrow) X = 12 \cos 41.8^\circ$ (or $12 \sin 48.2^\circ$)
 $= 8.94$

A1 ft
A1 3

[6]

20.

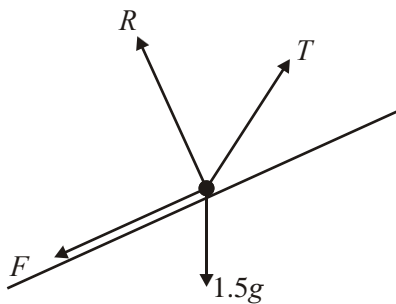

$$R(\nearrow): T \cos 20^\circ = F + 1.5g \sin 30^\circ$$

A2, 1, 0

$$R(\nwarrow): T \sin 20^\circ + R = 1.5g \cos 30^\circ$$

A2, 1, 0

Using $F = \frac{1}{3}R$

Eliminating R , solve T

$$T = 11 \text{ or } 11.0 \text{ N}$$

A1

[10]

21. (a)

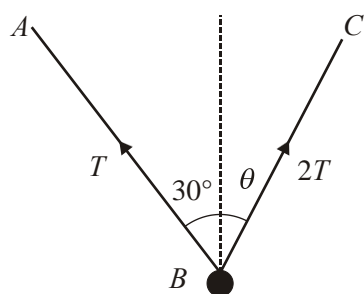

R(\rightarrow) $T \sin 30^\circ = 2T \sin \theta$ A1

$\Rightarrow \sin \theta = 0.25$

\Rightarrow $\theta \approx 14.5^\circ$ A1 4

(b) R(\uparrow) $T \cos 30 + 2T \cos \theta = 2g$ A1

$\Rightarrow T \approx 6.99 \text{ N}$ A1 4

[8]

1. This question was well answered, particularly by those who resolved vertically to produce one of their equations. Those who took moments about two different points had a higher failure rate, partly because of the need to represent more lengths in terms of x and partly because of the heavier algebra required. Most had the R and $3R$ the right way round, and few were tempted to swap over Tom and Sophie. There were seven significant points on the beam, and the candidates between them took moments about all seven. The least successful seemed to be those who took moments about Tom's position, which generally led to errors in the distances. A few took moments about a point but equated the sum of the moments to the reaction at the point producing a dimensionally incorrect equation and losing all the marks for that equation. It was rare to see g 's being used.
2. This question proved to be a good discriminator. The most popular approach was to resolve parallel and perpendicular to the plane (rather than horizontally and vertically which was much easier and avoided having to use simultaneous equations). The majority of candidates used $F = \mu R$ appropriately. Some, however, just equated the reaction to a weight component thereby simplifying the equations considerably and losing a significant number of marks. Candidates who did set up simultaneous equations correctly sometimes had difficulty in solving them to find the correct values for R and P , with poor use of brackets and algebraic manipulation contributing to this. A fairly common error was to give R in terms of P instead of calculating a numerical value for it. The final answers were required to be rounded to 2 or 3 significant figures for consistency with the use of $g = 9.8$ but this was not always observed and incurred a one mark penalty for the question.
3. Most candidates scored three marks for $F = P\cos 50^\circ$ and for $F = 0.2R$. However, errors were often made in the vertical resolution, with some ignoring P completely, giving $R = 15g$, while others included a component of P but made a sign error. A small minority of candidates was unable to eliminate R legitimately between their equations, while a significant number lost the final A1 for giving the answer as 36.9 (or 36.93).
4. Part (a) was usually correct with the majority of candidates producing a correct diagram. A significant minority had the friction force acting down the plane. In the second part by far the most popular approach was to resolve parallel and perpendicular to the plane, producing two simultaneous equations in P and R . There were many who went on to solve these correctly, but a common error was to find R in terms of P , use this to find a value for P , but then forget to go back and use it to find the value for R . A few of the more able students appreciated the idea of resolving perpendicular to an unknown force, and resolved vertically to find R , without the need to solve simultaneous equations.
5. Many were able, in the first part, to use \tan to find an acute angle, scoring two of the three marks, but were then unable to identify and find the required angle. In part (b), the first mark was for adding the two vectors together but many students then stated that this sum was equal to $(\mathbf{i} - 2\mathbf{j})$ rather than a multiple of it and were unable to make any progress. In the final part, many who failed in (b), obtained $p = -2$ from the printed equation and, even if their \mathbf{R} was wrong, were able to benefit from follow-through marks. It was amazing to see so many arrive correctly at $\sqrt{20} = m8\sqrt{5}$ then correctly write $m = 2\sqrt{5} / 8\sqrt{5}$ but then give $m = 5/4!$

6. This was a straightforward starter question and a majority of candidates got off to a good start. A few thought that $20/80$ were complementary angles whilst some did not check that their calculator was in degree mode.
- (a) Most were able to resolve correctly (with the occasional inevitable confusion between sin and cos) although some attempted to resolve parallel to the string, giving $T = W \cos 20 + 12 \sin 70$, but omitted one of the terms, thus scoring zero.
 - (b) Even if scoring zero in part (a), most candidates were able to gain 3 marks for this part. It is disturbing to find that a significant number of candidates for a Mechanics paper do not know the difference between mass and weight. A few candidates used the triangle of forces but sometimes slipped up by failing to take the essential step of drawing a separate triangle of forces diagram. Increasingly rarely seen, a few candidates successfully used Lami's theorem.
7. (a) In a number of cases the vertical component of the tension was missing; a few missed out the weight, and a small minority "resolved" it. Some mixed up sine and cosine and a few subtracted 40 from 90 to give 60. There was some very poor algebraic manipulation, going from a correct first statement, to an incorrect value for R .
- (b) Most candidates earned the B mark, for knowing that $F = uR$ and the majority could get $F = 1.2 \cos 40$ (or $1.2 \sin 40$) and so, even getting part (a) completely incorrect, could gain 5 out of 6 marks for (b). As usual, rounding and accuracy, when using g , caused some problems
8. This proved to be a good starter for the majority of candidates, with most resolving horizontally and vertically, although a few chose to resolve parallel and perpendicular to P . Common errors included "24g" instead of "24" and the mixing up of sin and cos. $P = 24 \sin 30$ was also often seen. A small number attempted to use a triangle of forces with mixed success.
9. This was generally well done and many fully correct solutions were seen to part (a). However, a number of weaker candidates could not handle the angle in question (e.g using 0.75 degrees); also some weaker candidates were evidently confused about what precisely 'F' was in the equations $F = \mu R$ and $F = ma$. In part (b) a number of candidates also lost marks by effectively omitting one of the two terms in the equation of motion, forgetting about either the friction or (more commonly) the component of the weight acting down the plane.
10. In parts (a) and (b) candidates managed to recover and most could make good attempts here. Most could resolve perpendicular to the plane and parallel to the plane, with a correct use of the frictional force. Some lost marks by omitting forces, but several gained at least all the method marks here. Part (c) proved to be more discriminating, at least for gaining all 5 marks. Some could make little progress since they did not realise that the normal reaction had now changed. Others did realise this and could get to the stage of setting up the value of the component of the

weight down the plane and the value of μR . However it proved to be very difficult for candidates to understand clearly that ' μR ' was not necessarily the actual frictional force acting (except in limiting equilibrium): hence there were many final answers to part (c) stating that the box remained in equilibrium 'because the frictional force was greater than the component of the weight'.

11. This question proved to be more of a discriminator. In part (a), most appeared to realise that they should be trying to resolve horizontally (though they did not always say so!), but even here there were some errors in the trigonometry. There were also some confused attempts at 'triangle of forces' approaches, though as often as not confusing a possible triangle of forces with the triangle in the given diagram. In part (b) only the better candidates realised that the tension in the same throughout the string and those who did not realise this could make little progress. Some ignored one part of the string completely; others took the tension in the vertical part to the vertical component of the tension in the sloping part.
12. Parts (a) and (b) were generally well answered, though several lost a mark by failing to give their answers to an 'appropriate' degree of accuracy (which here, as in all questions using g as 9.8m , was to 2 or 3 significant figures). Part (c) was however very poorly answered. Several simply assumed that the value of the frictional force was equal to its value in limiting equilibrium, and then confidently stated that as the frictional force was *greater* than the component of the weight, equilibrium resulted (failing apparently to realise that equilibrium requires a zero net force). The condition that, for friction, F had to be *less than* (rather than equal to) μR was clearly not understood by the vast majority of candidates.
13. This proved to be the most discriminating question on the paper and not so many fully correct answers were seen. A common mistake in part (a) was to assume that the friction was acting down, rather than up, the slope for the minimum force. Several then went on to repeat the same working in part (b) (which was of course then correct). Several too failed to round their answers to an appropriate degree of accuracy (having used g as 9.8 , they should have given their answers to no more than 3 significant figures). Explanations in part (c) were fair, with answers to (ii) better than answers to (i). In the latter case, it was often not clear from the statement written what exactly was being asserted: a succinct statement is all that is required – but it must be clear!
14. The majority of candidates scored well on this question and made a good start to the paper. Most realised that they had to resolve the forces. However, a surprising number took the magnitudes of the tensions as the lengths of the (sloping) sides on the given triangle, effectively assuming that the given triangle was a triangle of forces. Such candidates often went on correctly into the second part of the question by resolving vertically. A number of candidates also confused weight and mass in part (b).

15. Some very good answers were seen to this question with many fully correct (or all but correct) answers. However, as with Q4, many again lost a mark by giving their answers (especially in part (a)) to 4 or more significant figures. The most common other mistake in (a) was to have the wrong sign with the friction in the equilibrium equation. It was however pleasing to note the very high standard generally of accuracy in processing the resulting equation here with awkward figures involved. In part (b), most realised that they had to find the acceleration, but several omitted one or other of the relevant forces in doing so. Most however could use their resulting acceleration to find a value of the time appropriately.
16. This proved to be one of the hardest questions on the paper. Very few clearly understood that there were three separate objects in the system and hence forces on each needed to be considered. Connected objects in equilibrium was evidently a topic that was found to be new for many (although it is a common problem in a dynamics situation); hence many failed to realise that the tensions at the ends of the strings were acting in opposite directions. Few drew clear force diagrams with all the forces clearly marked: those who did benefited themselves and then successfully completed the question.
17. Candidates began to recover a little in question 3, with a fair number of correct approaches and only an odd mark or two dropped for algebraic or arithmetic errors. There were though still a significant number of candidates who thought that the normal reaction was simply $50g$. A number of candidates also lost a mark by failing to give their answers to no more than 3 s.f. (in a calculation which has used g as 9.8): several appeared to think that one decimal place was an 'appropriate' degree of accuracy.
18. It was pleasing to see rather fewer candidates than has sometimes been the case simply writing down ' $R = mg \cos a$ '. Most realised that they had to resolve in two directions. Some mistakes did however arise from candidates failing to have the friction acting in the right direction. Work was not always well presented with expressions such as ' $\sin \frac{3}{5}$ ' or ' $\cos \frac{4}{5}$ ' written down. Sometimes candidates appeared to mean the correct thing by this, but often scripts provided a considerable challenge of interpretation to examiners!
19. Of the early questions, this was perhaps the most demanding, with some weaker candidates offering no attempt at all. Most realised that they had to resolve, but many failed to specify the direction in which they were attempting to resolve. There was often too considerable confusion about the angle which they were using, with little consistency between the q given in the question and that used by the candidates. Only the stronger candidates gave a clear indication in the diagram which acute angle they were finding in part (a) and then used that consistently to find the obtuse angle q as required. In part (b) several spurious attempts were seen, attempting to resolve using the obtuse angle directly.

- 20.** As far as the mechanics of the question was concerned, this was generally well done. A significant minority still oversimplified the problem considerably by assuming that the normal reaction was $1.5g \cos 30$. However, many others succeeded in writing down two appropriate equations and then seeking to solve to find the tension. There was an inevitable crop of errors in solving the equations, but generally the approaches adopted were sound.
- 21.** No Report available for this question.