

1.

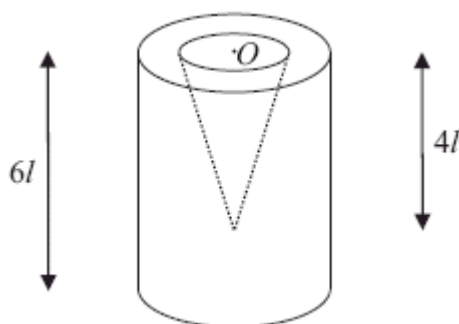

Figure 1

A container is formed by removing a right circular solid cone of height  $4l$  from a uniform solid right circular cylinder of height  $6l$ . The centre  $O$  of the plane face of the cone coincides with the centre of a plane face of the cylinder and the axis of the cone coincides with the axis of the cylinder, as shown in Figure 1. The cylinder has radius  $2l$  and the base of the cone has radius  $l$ .

(a) Find the distance of the centre of mass of the container from  $O$ .

(6)

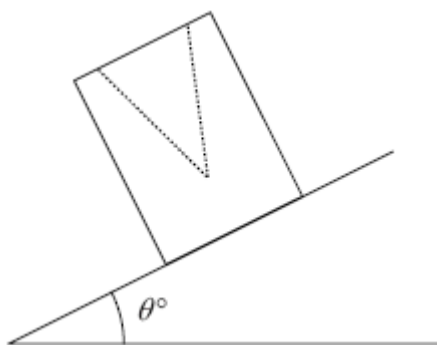

Figure 2

The container is placed on a plane which is inclined at an angle  $\theta^\circ$  to the horizontal. The open face is uppermost, as shown in Figure 2. The plane is sufficiently rough to prevent the container from sliding. The container is on the point of toppling.

(b) Find the value of  $\theta$ .

(4)

(Total 10 marks)

2.

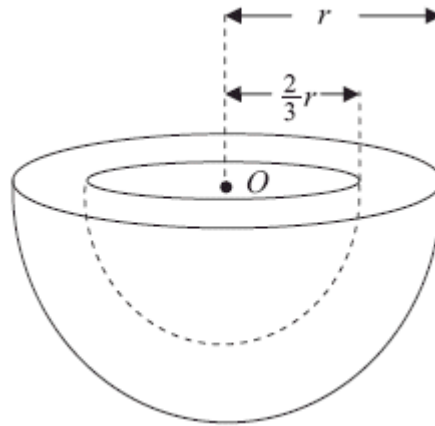

Figure 1

A bowl  $B$  consists of a uniform solid hemisphere, of radius  $r$  and centre  $O$ , from which is removed a solid hemisphere, of radius  $\frac{2}{3}r$  and centre  $O$ , as shown in Figure 1.

- (a) Show that the distance of the centre of mass of  $B$  from  $O$  is  $\frac{65}{152}r$ .

(5)

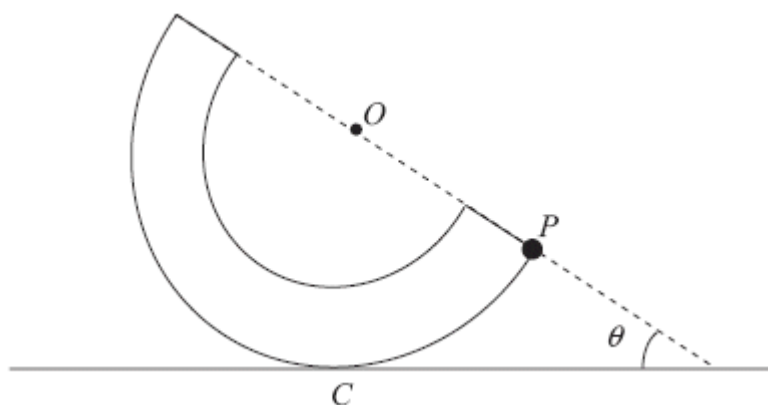

Figure 2

The bowl  $B$  has mass  $M$ . A particle of mass  $kM$  is attached to a point  $P$  on the outer rim of  $B$ . The system is placed with a point  $C$  on its outer curved surface in contact with a horizontal plane. The system is in equilibrium with  $P$ ,  $O$  and  $C$  in the same vertical plane. The line  $OP$  makes an angle  $\theta$  with the horizontal as shown in Figure 2. Given that  $\tan \theta = \frac{4}{5}$ ,

(b) find the exact value of  $k$ .

(5)  
(Total 10 marks)

3. [The centre of mass of a uniform hollow cone of height  $h$  is  $\frac{1}{3}h$  above the base on the line from the centre of the base to the vertex.]

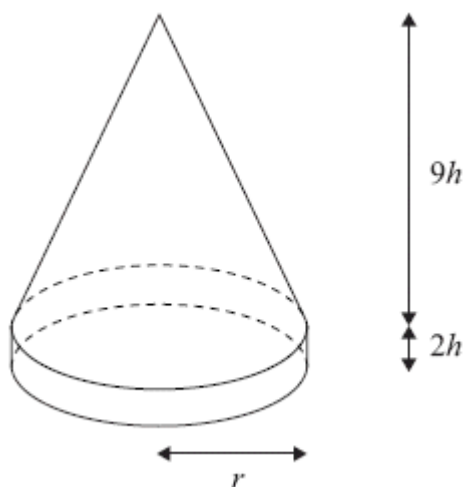

A marker for the route of a charity walk consists of a uniform hollow cone fixed on to a uniform solid cylindrical ring, as shown in the diagram above. The hollow cone has base radius  $r$ , height  $9h$  and mass  $m$ . The solid cylindrical ring has outer radius  $r$ , height  $2h$  and mass  $3m$ . The marker stands with its base on a horizontal surface.

- (a) Find, in terms of  $h$ , the distance of the centre of mass of the marker from the horizontal surface.

(5)

When the marker stands on a plane inclined at  $\arctan \frac{1}{12}$  to the horizontal it is on the point of toppling over. The coefficient of friction between the marker and the plane is large enough to be certain that the marker will not slip.

- (b) Find  $h$  in terms of  $r$ .

(3)

(Total 8 marks)

4. The finite region bounded by the  $x$ -axis, the curve  $y = \frac{1}{x^2}$ , the line  $x = \frac{1}{4}$  and the line  $x = 1$ , is rotated through one complete revolution about the  $x$ -axis to form a uniform solid of revolution.

- (a) Show that the volume of the solid is  $21\pi$ .

(4)

- (b) Find the coordinates of the centre of mass of the solid.

(5)

(Total 9 marks)

5.

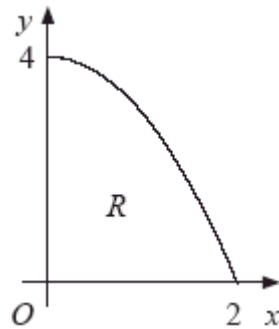

Figure 1

The region  $R$  is bounded by part of the curve with equation  $y = 4 - x^2$ , the positive  $x$ -axis and the positive  $y$ -axis, as shown in Figure 1. The unit of length on both axes is one metre. A uniform solid  $S$  is formed by rotating  $R$  through  $360^\circ$  about the  $x$ -axis.

(a) Show that the centre of mass of  $S$  is  $\frac{5}{8}$  m from  $O$ .

(10)

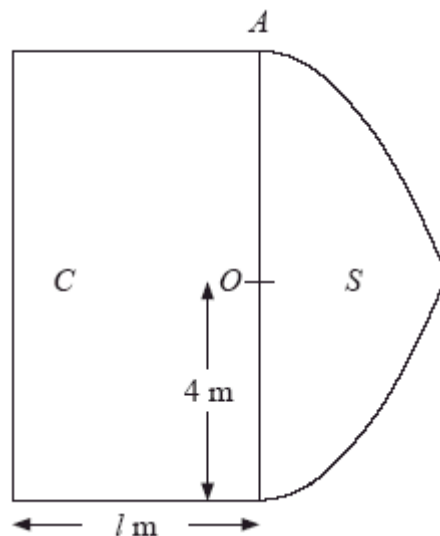

Figure 2

Figure 2 shows a cross section of a uniform solid  $P$  consisting of two components, a solid cylinder  $C$  and the solid  $S$ . The cylinder  $C$  has radius 4 m and length  $l$  metres. One end of  $C$  coincides with the plane circular face of  $S$ . The point  $A$  is on the circumference of the circular face common to  $C$  and  $S$ . When the solid  $P$  is freely suspended from  $A$ , the solid  $P$  hangs with its axis of symmetry horizontal.

(b) Find the value of  $l$ .

(4)

(Total 14 marks)

6.

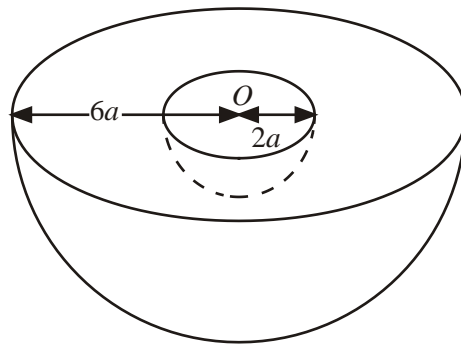

Figure 1

A uniform solid hemisphere, of radius  $6a$  and centre  $O$ , has a solid hemisphere of radius  $2a$ , and centre  $O$ , removed to form a bowl  $B$  as shown in Figure 1.

- (a) show that the centre of mass of  $B$  is  $\frac{30}{13}a$  from  $O$ .

(5)

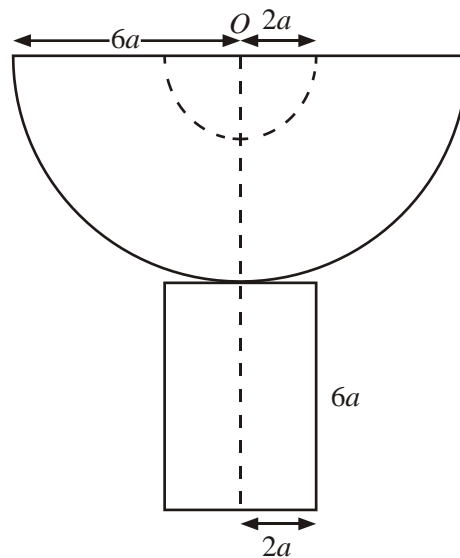

Figure 2

The bowl  $B$  is fixed to a plane face of a uniform solid cylinder made from the same material as  $B$ . The cylinder has radius  $2a$  and height  $6a$  and the combined solid  $S$  has an axis of symmetry which passes through  $O$ , as shown in Figure 2.

- (b) Show that the centre of mass of  $S$  is  $\frac{201}{61}a$  from  $O$ .

(4)

The plane surface of the cylindrical base of  $S$  is placed on a rough plane inclined at  $12^\circ$  to the horizontal. The plane is sufficiently rough to prevent slipping.

- (c) Determine whether or not  $S$  will topple.

(4)

(Total 13 marks)

7. An open container  $C$  is modelled as a thin uniform hollow cylinder of radius  $h$  and height  $h$  with a base but no lid. The centre of the base is  $O$ .

- (a) Show that the distance of the centre of mass of  $C$  from  $O$  is  $\frac{1}{3}h$ .

(5)

The container is filled with uniform liquid. Given that the mass of the container is  $M$  and the mass of the liquid is  $M$ ,

- (b) find the distance of the centre of mass of the filled container from  $O$ .

(5)

(Total 10 marks)

8.

Figure 1

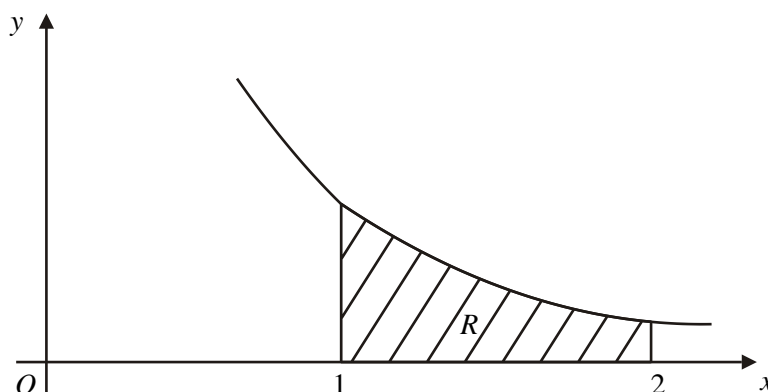

The shaded region  $R$  is bounded by the curve with equation  $y = \frac{1}{2x^2}$ , the  $x$ -axis and the lines  $x = 1$  and  $x = 2$ , as shown in Figure 1. The unit of length on each axis is 1 m. A uniform solid  $S$  has the shape made by rotating  $R$  through  $360^\circ$  about the  $x$ -axis.

- (a) Show that the centre of mass of  $S$  is  $\frac{2}{7}m$  from its larger plane face.

(6)

Figure 2

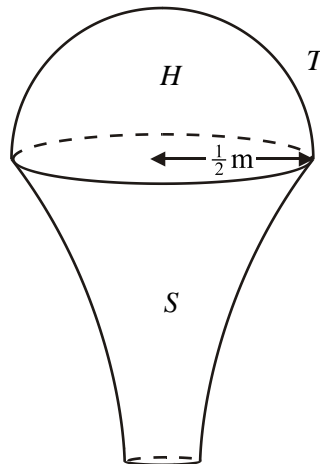

A sporting trophy  $T$  is a uniform solid hemisphere  $H$  joined to the solid  $S$ . The hemisphere has radius  $\frac{1}{2}m$  and its plane face coincides with the larger plane face of  $S$ , as shown in Figure 2. Both  $H$  and  $S$  are made of the same material.

- (b) Find the distance of the centre of mass of  $T$  from its plane face.

(7)

(Total 13 marks)

9. A uniform solid is formed by rotating the region enclosed between the curve with equation  $y = \sqrt{x}$ , the  $x$ -axis and the line  $x = 4$ , through one complete revolution about the  $x$ -axis. Find the distance of the centre of mass of the solid from the origin  $O$ .

(Total 5 marks)



10. A bowl consists of a uniform solid metal hemisphere, of radius  $a$  and centre  $O$ , from which is removed the solid hemisphere of radius  $\frac{1}{2}a$  with the same centre  $O$ .

(a) Show that the distance of the centre of mass of the bowl from  $O$  is  $\frac{45}{112}a$ .

(5)

The bowl is fixed with its plane face uppermost and horizontal. It is now filled with liquid. The mass of the bowl is  $M$  and the mass of the liquid is  $kM$ , where  $k$  is a constant. Given that the distance of the centre of mass of the bowl and liquid together from  $O$  is  $\frac{17}{48}a$ ,

- (b) find the value of  $k$ .

(5)

(Total 10 marks)

11.

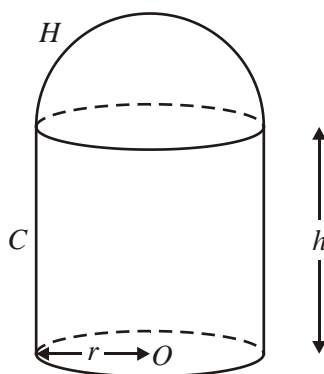

A body consists of a uniform solid circular cylinder  $C$ , together with a uniform solid hemisphere  $H$  which is attached to  $C$ . The plane face of  $H$  coincides with the upper plane face of  $C$ , as shown in the figure above. The cylinder  $C$  has base radius  $r$ , height  $h$  and mass  $3M$ . The mass of  $H$  is  $2M$ . The point  $O$  is the centre of the base of  $C$ .

- (a) Show that the distance of the centre of mass of the body from  $O$  is

$$\frac{14h + 3r}{20}.$$

(5)

The body is placed with its plane face on a rough plane which is inclined at an angle  $\alpha$  to the horizontal, where  $\tan \alpha = \frac{4}{3}$ . The plane is sufficiently rough to prevent slipping. Given that the body is on the point of toppling,

- (b) find  $h$  in terms of  $r$ .

(4)

(Total 9 marks)

12. A closed container  $C$  consists of a thin uniform hollow hemispherical bowl of radius  $a$ , together with a lid. The lid is a thin uniform circular disc, also of radius  $a$ . The centre  $O$  of the disc coincides with the centre of the hemispherical bowl. The bowl and its lid are made of the same material.

- (a) Show that the centre of mass of  $C$  is at a distance  $\frac{1}{3}a$  from  $O$ .

(4)

The container  $C$  has mass  $M$ . A particle of mass  $\frac{1}{2}M$  is attached to the container at a point  $P$  on the circumference of the lid. The container is then placed with a point of its curved surface in contact with a horizontal plane. The container rests in equilibrium with  $P$ ,  $O$  and the point of contact in the same vertical plane.

- (b) Find, to the nearest degree, the angle made by the line  $PO$  with the horizontal.

(5)

(Total 9 marks)

13.

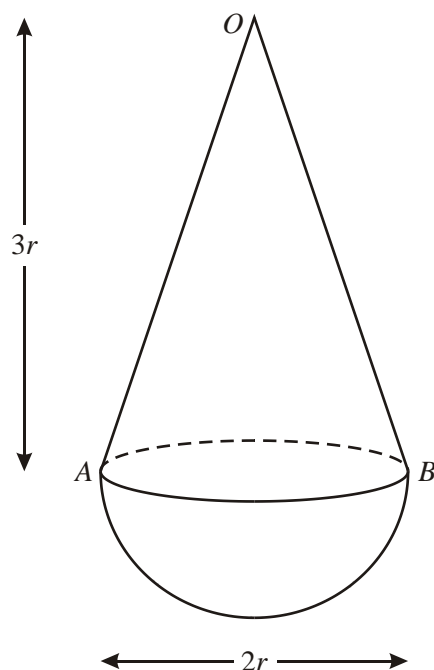

A child's toy consists of a uniform solid hemisphere, of mass  $M$  and base radius  $r$ , joined to a uniform solid right circular cone of mass  $m$ , where  $2m < M$ . The cone has vertex  $O$ , base radius  $r$  and height  $3r$ . Its plane face, with diameter  $AB$ , coincides with the plane face of the hemisphere, as shown in the diagram above.

- (a) Show that the distance of the centre of mass of the toy from  $AB$  is

$$\frac{3(M - 2m)}{8(M + m)}r.$$

(5)

The toy is placed with  $OA$  on a horizontal surface. The toy is released from rest and does not remain in equilibrium.

- (b) Show that  $M > 26m$ .

(4)

(Total 9 marks)

14.

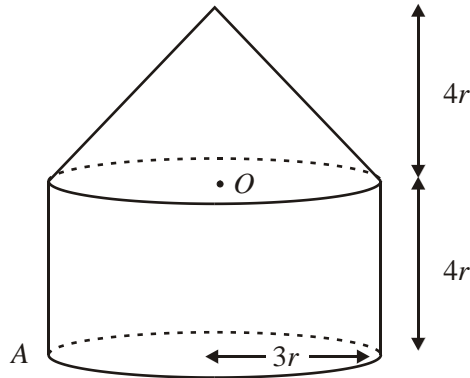

A toy is formed by joining a uniform solid right circular cone, of base radius  $3r$  and height  $4r$ , to a uniform solid cylinder, also of radius  $3r$  and height  $4r$ . The cone and the cylinder are made from the same material, and the plane face of the cone coincides with a plane face of the cylinder, as shown in the diagram above. The centre of this plane face is  $O$ .

- (a) Find the distance of the centre of mass of the toy from  $O$ .

(5)

The point  $A$  lies on the edge of the plane face of the cylinder which forms the base of the toy. The toy is suspended from  $A$  and hangs in equilibrium.

- (b) Find, in degrees to one decimal place, the angle between the axis of symmetry of the toy and the vertical.

(4)

The toy is placed with the curved surface of the cone on horizontal ground.

- (c) Determine whether the toy will topple.

(4)

(Total 13 marks)

15.

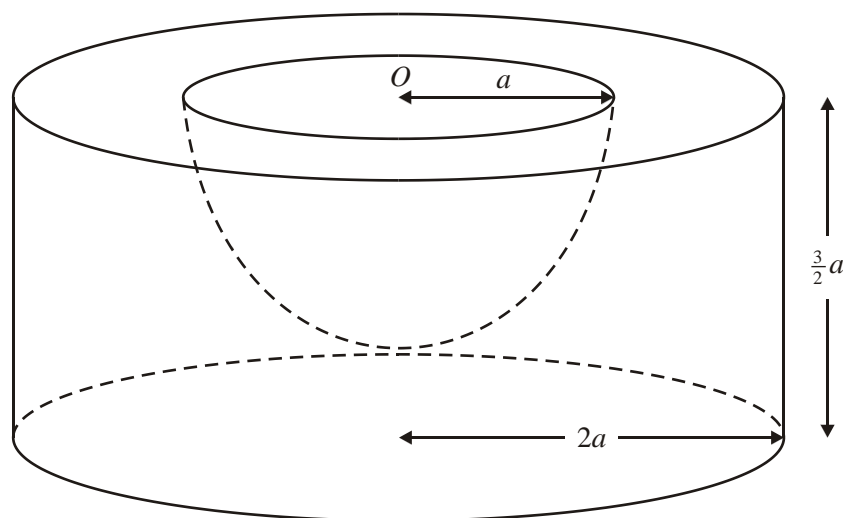

A uniform solid cylinder has radius  $2a$  and height  $\frac{3}{2}a$ . A hemisphere of radius  $a$  is removed from the cylinder. The plane face of the hemisphere coincides with the upper plane face of the cylinder, and the centre  $O$  of the hemisphere is also the centre of this plane face, as shown in the diagram above. The remaining solid is  $S$ .

(a) Find the distance of the centre of mass of  $S$  from  $O$ .

(6)

The lower plane face of  $S$  rests in equilibrium on a desk lid which is inclined at an angle  $\theta$  to the horizontal. Assuming that the lid is sufficiently rough to prevent  $S$  from slipping, and that  $S$  is on the point of toppling when  $\theta = \alpha$ ,

(b) find the value of  $\alpha$ .

(3)

Given instead that the coefficient of friction between  $S$  and the lid is 0.8, and that  $S$  is on the point of sliding down the lid when  $\theta = \beta$ ,

(c) find the value of  $\beta$ .

(3)

**(Total 12 marks)**

16.

Figure 1

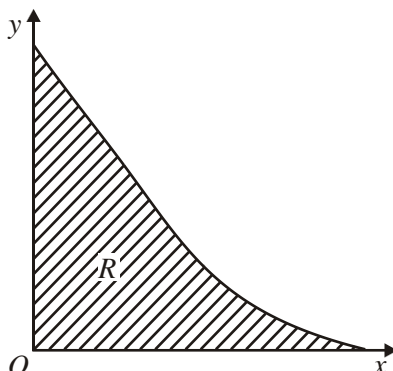

The shaded region  $R$  is bounded by part of the curve with equation  $y = \frac{1}{2}(x-2)^2$ , the  $x$ -axis and the  $y$ -axis, as shown in Fig. 1. The unit of length on both axes is 1 cm. A uniform solid  $S$  is made by rotating  $R$  through  $360^\circ$  about the  $x$ -axis. Using integration,

- (a) calculate the volume of the solid  $S$ , leaving your answer in terms of  $\pi$ , (4)
- (b) show that the centre of mass of  $S$  is  $\frac{1}{3}$  cm from its plane face. (7)

Figure 2

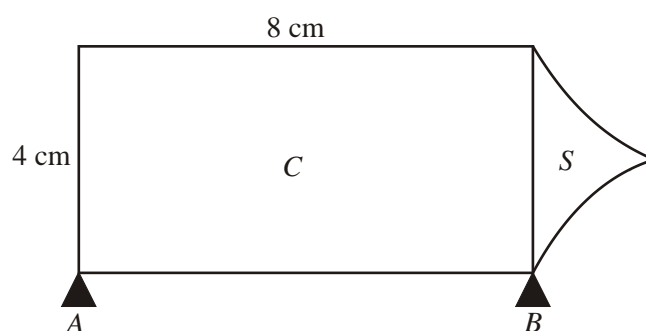

A tool is modelled as having two components, a solid uniform cylinder  $C$  and the solid  $S$ . The diameter of  $C$  is 4 cm and the length of  $C$  is 8 cm. One end of  $C$  coincides with the plane face of  $S$ . The components are made of different materials. The weight of  $C$  is  $10W$  newtons and the weight of  $S$  is  $2W$  newtons. The tool lies in equilibrium with its axis of symmetry horizontal on two smooth supports  $A$  and  $B$ , which are at the ends of the cylinder, as shown in Fig. 2.

- (c) Find the magnitude of the force of the support  $A$  on the tool. (5)

(Total 16 marks)

17.

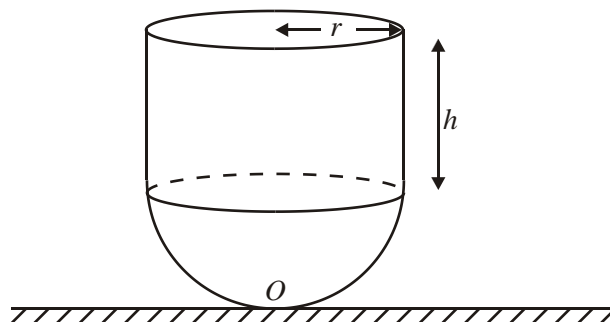

A child's toy consists of a uniform solid hemisphere attached to a uniform solid cylinder. The plane face of the hemisphere coincides with the plane face of the cylinder, as shown in the diagram above. The cylinder and the hemisphere each have radius  $r$ , and the height of the cylinder is  $h$ . The material of the hemisphere is 6 times as dense as the material of the cylinder. The toy rests in equilibrium on a horizontal plane with the cylinder above the hemisphere and the axis of the cylinder vertical.

- (a) Show that the distance  $d$  of the centre of mass of the toy from its lowest point  $O$  is given by

$$d = \frac{h^2 + 2hr + 5r^2}{2(h + 4r)}.$$

(7)

When the toy is placed with any point of the curved surface of the hemisphere resting on the plane it will remain in equilibrium.

- (b) Find  $h$  in terms of  $r$ .

(3)

**(Total 10 marks)**

18. (a) Show, by integration, that the centre of mass of a uniform right cone, of radius  $a$  and height  $h$ , is a distance  $\frac{3}{4}h$  from the vertex of the cone.

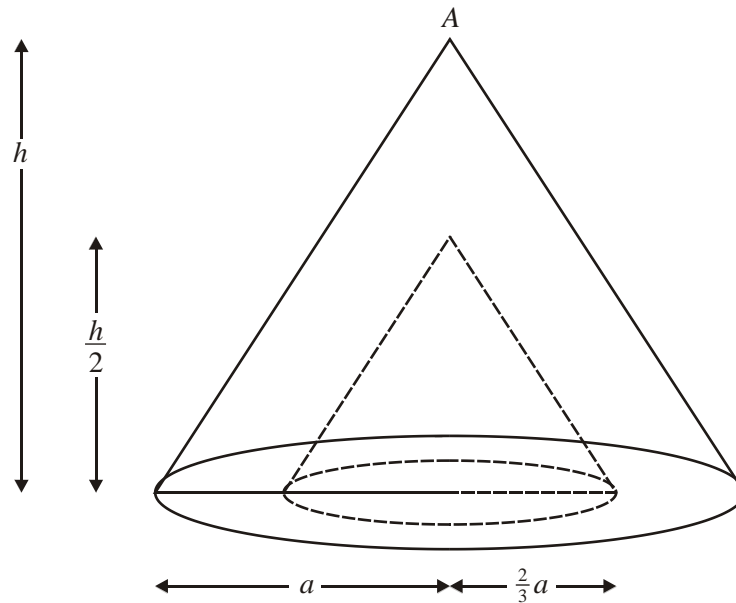

A uniform right cone  $C$ , of radius  $a$  and height  $h$ , has vertex  $A$ . A solid  $S$  is formed by removing from  $C$  another cone, of radius  $\frac{2}{3}a$  and height  $\frac{1}{2}h$ , with the same axis as  $C$ . The plane faces of the two cones coincide, as shown in the diagram above.

- (b) Find the distance of the centre of mass of  $S$  from  $A$ .

(Total 7 marks)



1. (a)

	cone	container	cylinder
mass ratio	$\frac{4\pi l^3}{3}$	$\frac{68\pi l^3}{3}$	$24\pi l^3$
	4	68	72
dist from $O$	$l$	$\bar{x}$	$3l$

M1 A1

B1

Moments:

$$4l + 68\bar{x} = 72 \times 3l$$

M1 A1ft

$$\bar{x} = \frac{212l}{68} = \frac{53}{17}l \quad \text{accept } 3.12l$$

A1

6

(b)

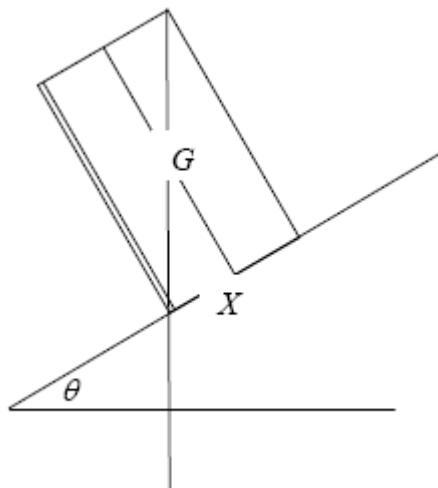

$$GX = 6l - \bar{x} \quad \text{seen}$$

M1

$$\begin{aligned} \tan \theta &= \frac{2l}{6l - \bar{x}} \\ &= \frac{2 \times 17}{49} \end{aligned}$$

M1 A1

$$\theta = 34.75\dots = 34.8 \quad \text{or } 35$$

A1

4

[10]

2. (a)

Mass ratios

$$\begin{matrix} s & B & S \\ 8 & 19 & 27 \end{matrix}$$

anything in correct ratio

B1

$$\bar{x} = \frac{3}{8} \times \frac{2}{3} r \quad \bar{x} = \frac{3}{8} r$$

B1

$$8 \times \frac{1}{4} r + 19\bar{x} = 27 \times \frac{3}{8} r$$

M1 A1ft

$$\bar{x} = \frac{65}{152} r \quad *$$

A1

5

(b)

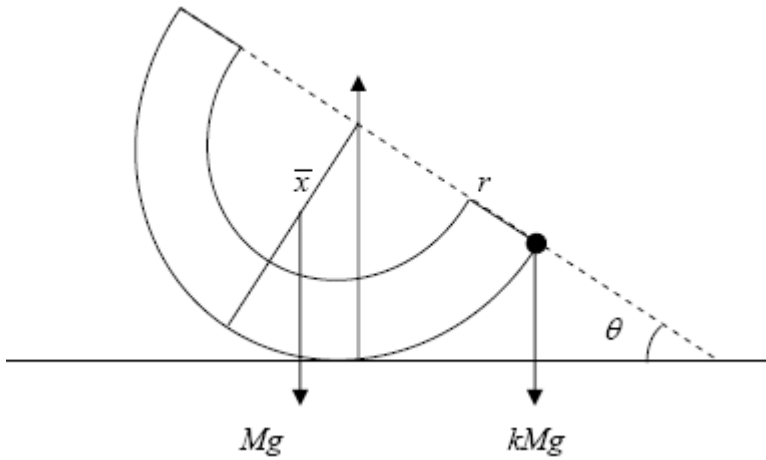

$$Mg \times \bar{x} \sin\theta = kMg \times r \cos\theta$$

M1 A1=A1

leading to  $k = \frac{13}{38}$

M1 A1 5

[10]

3.	(a)	Object	Mass	c of m above base	B1(ratio masses)
		Cone	$m$	$2h+3h$	
		Base	$3m$	$h$	B1(distances)
		Marker	$4m$	$d$	
		$m \times 5h + 3m \times h = 4m \times d$			M1A1ft
		$d = 2h$			A1

(b)

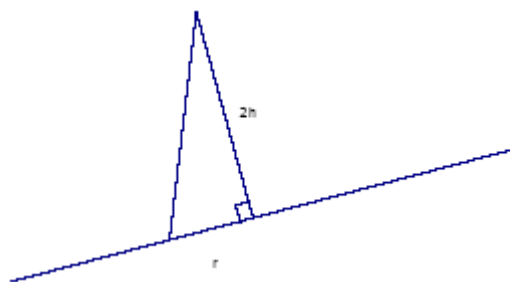

$$\frac{r}{d} = \frac{1}{12}$$

M1A1ft

$$6r = h$$

A1

[8]

$$4. \quad (a) \quad \text{Volume} = \int_{\frac{1}{4}}^1 \pi y^2 dx = \int_{\frac{1}{4}}^1 \pi \frac{1}{x^4} dx \quad \text{M1A1}$$

$$\left[ \pi \times \frac{-1}{3x^3} \right]_{\frac{1}{4}}^1 \quad \text{A1ft}$$

$$= \pi \left( \frac{-1}{3} + \frac{64}{3} \right) = 21\pi \quad *$$

$$(b) \quad 21\pi\rho\bar{x} = \rho \int \pi y^2 x dx = \rho \int \pi \frac{1}{x^4} x dx \quad \text{M1A1}$$

$$21\pi\bar{x} = \pi \left[ \frac{-1}{2x^2} \right]_{\frac{1}{4}}^1 \quad \text{A1ft}$$

$$\bar{x} = \frac{1}{21} \left( \frac{-1}{2} + \frac{16}{2} \right) = \frac{5}{14} \quad \text{or awrt } 0.36 \quad \text{A1}$$

$$\bar{y} = 0 \text{ by symmetry} \quad \text{B1}$$

**[9]**

$$5. \quad (a) \quad \int y^2 dx = \int (4-x^2)^2 dx = \int (16-8x^2+x^4) dx$$

$$= 16x - \frac{8x^3}{3} + \frac{x^5}{5} \quad \text{M1 A1}$$

$$\left[ 16x - \frac{8x^3}{3} + \frac{x^5}{5} \right]_0^2 = \frac{256}{15} \quad \text{M1 A1}$$

$$\int xy^2 dx = \int x(4-x^2)^2 dx = \int (16x-8x^3+x^5) dx$$

$$= 8x^2 - 2x^4 + \frac{x^6}{6} \quad \text{M1 A1}$$

$$\left[ 8x^2 - 2x^4 + \frac{x^6}{6} \right]_0^2 = \frac{32}{3} \quad \text{M1 A1}$$

$$\frac{\int xy^2 dx}{\int y^2 dx} = \frac{32}{3} \times \frac{15}{216} = \frac{5}{8} \quad *$$

M1 A1 10

(b)  $A \times \bar{x} = (\pi r^2 l) \times \frac{l}{2}$  M1

$$\frac{256}{15} \pi \times \frac{5}{8} = \pi \times 16l \times \frac{l}{2}$$

A1 ft

Leading to  $l = \frac{2\sqrt{3}}{3}$  accept exact equivalents or awrt 1.15 M1 A1 4

[14]

6. (a)



Mass  $a^3 \frac{2}{3} \pi \times$ :  $\frac{216}{27}$   $\frac{8}{1}$   $\frac{208}{26}$  M1A1

C of M from O:  $\frac{3}{8} \times 6a$   $\frac{3}{8} \times 2a$   $\bar{x}$  Use of  $\frac{3}{8}r$  M1

Moment:  $216 \times \frac{6a \times 3}{8} = 8 \times \frac{2a \times 3}{8} + 208\bar{x}$  M1

$$\bar{x} = \frac{480a}{208} = \frac{30a}{13}^*$$

A1 cso 5

(b)



Mass  $\pi a^3 \times$ :  $\frac{416}{3}$  + 24 =  $\frac{488}{3}$  B1

C of M:  $\frac{30}{13}a$  +  $9a$  =  $\bar{y}$  B1

Moments:  $320a$  +  $216a$  =  $\frac{488}{3}\bar{y}$  M1

A1cso 4

(c)



$12a - \frac{201}{61}a$  M1

$$\tan \theta = \frac{2a}{12a - \frac{201}{61}a} \quad \tan \theta = \frac{2a}{\dots}$$

$\theta = 12.93\dots$  A1

so critical angle = 12.93...  $\therefore$  if  $\theta = 12^\circ$  it will NOT topple. A1 4

[13]

7.	(a)	Base	Cylinder	Container		
	Mass ratios	$\pi h^2$	$2\pi h^2$	$3\pi h^2$	Ratio of 1 : 2 : 3	B1
	$\bar{y}$	0	$\frac{h}{2}$	$\bar{y}$		B1
		$3\pi h^2 \times \bar{y} = 2\pi h^2 \times \frac{h}{2}$	M1A1			
	Leading to	$\bar{y} = \frac{1}{3}h^*$			cso	A1 5

(b)	Mass ratios	Liquid	Container	Total	Ratio of 1 : 1 : 2	B1
	$\bar{y}$	$\frac{h}{2}$	$\frac{h}{3}$	$\bar{y}$		B1
		$2M \times \bar{y} = M \times \frac{h}{2} + M \times \frac{h}{3}$	M1A1			
		$\bar{y} = \frac{5}{12}h$			A1	5

[10]

8.	(a)	Moments: $\pi \int_1^2 xy^2 dx = V\bar{x}$ or $\int_1^2 xy^2 dx = \bar{x} \int_1^2 y^2 dx$	M1
		$\int_1^2 y^2 dx = \int_1^2 \frac{1}{4x^2} dx = \left[ -\frac{1}{12x^3} \right]_1^2 = \left( -\frac{7}{96} \right)$	(either) M1A1
		$\int_1^2 xy^2 dx = \int_1^2 \frac{1}{4x^3} dx = \left[ -\frac{1}{8x^2} \right]_1^2 = \left( -\frac{3}{32} \right)$	(both) A1
		Solving to find $\bar{x} (= \frac{9}{7}) \Rightarrow$ required dist = $\frac{9}{7} - 1 = \frac{2}{7}$ m (*)	M1 A1cso 6

(b)	H	S	T	
Mass	$(\rho) \frac{2}{3} \pi \left( \frac{1}{2} \right)^3$	$(\rho) \frac{7\pi}{96}$	$H + S$	
	$\left[ = \frac{1}{12} (\rho) \pi \right]$		$\left[ = \frac{5}{32} (\rho) \pi \right]$	B1, M1
Dist of CM from base	$\frac{19}{16}$ m	$\frac{5}{7}$ m	$\bar{x}$	B1B1
Moments:	$\left[ = \frac{1}{12} (\rho) \pi \right] \left( \frac{19}{16} \right) + (\rho) \frac{7\pi}{96} \left( \frac{5}{7} \right) = \left[ \frac{5}{32} (\rho) \pi \right] \bar{x}$			M1A1
	$\bar{x} = \frac{29}{30}$ m or 0.967 m (awrt)			A1 7

Allow distances to be found from different base line if necessary

[13]

9. Use of  $(\pi) \int y^2 dx \times \bar{x} = (\pi) \int xy^2 dx$  M1

$$\int x dx \times \bar{x} = \int x^2 dx$$

$$\left[ \frac{1}{2} x^2 \right]_{\dots}^{\dots} \times \bar{x} = \left[ \frac{1}{3} x^3 \right]_{\dots}^{\dots}$$

A1 = A1

Using limits 0 and 4  $\frac{16}{2} \times \bar{x} = \frac{64}{3}$  M1

$$\bar{x} = \frac{8}{3}$$

A1 5

[5]

10. (a)

	Small Hemisphere	Bowl	Large Hemisphere	
Mass ratios	$\frac{2}{3} \pi \left(\frac{a}{2}\right)^3$	$\frac{2}{3} \pi \frac{7a^3}{8}$	$\frac{2}{3} \pi a^3$	B1
	<i>Anything in the ratio 1 : 7 : 8</i>			
$\bar{x}$	$\frac{3}{16} a$	$\bar{x}$	$\frac{3}{8} a$	B1
	$1 \times \frac{3}{16} a + 7 \times \bar{x} = 8 \times \frac{3}{8} a$			M1 A1
	Leading to	$\bar{x} = \frac{45}{112} a$	cso	A1 5

(b)

	Bowl	Liquid	Bowl and Liquid	
Mass ratios	$M$	$kM$	$(k+1)M$	B1
$\bar{x}$	$\frac{45}{112} a$	$\frac{3}{16} a$	$\frac{17}{48} a$	B1
	$M \times \frac{45}{112} a + kM \times \frac{3}{16} a = (k+1)M \times \frac{17}{48} a$			M1 A1
	Leading to $k = \frac{2}{7}$			A1 5

[10]

11. (a)  $5M\bar{x} = 3M \times \frac{h}{2} + 2M \left( h + \frac{3}{8} r \right)$  M1 A2(1, 0)

$$5\bar{x} = \frac{3h}{2} + 2h + \frac{3}{4} r = \frac{7h}{2} + \frac{3}{4} r$$

$$\bar{x} = \frac{14h + 3r}{20}$$

cso

M1 A1

5

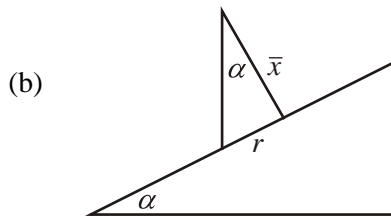

$$\tan \alpha = \frac{20r}{14h + 3r} = \frac{4}{3}$$

M1 A1

Leading to  $h = \frac{6}{7}r$

M1 A1

4

[9]

12. (a)

	Bowl	Lid	C	
Mass ratio	2	1	3	anything in ratio 2 : 1 : 3
$\bar{y}$	$\frac{1}{2}a$	0	$\bar{y}$	B1
$M(O)$	$2 \times \frac{1}{2}a = 3\bar{y}$			M1
	$\bar{y} = \frac{1}{3}a (*)$			csoA1

anything in ratio 2 : 1 : 3

B1

B1

M1

csoA1

4

(b)

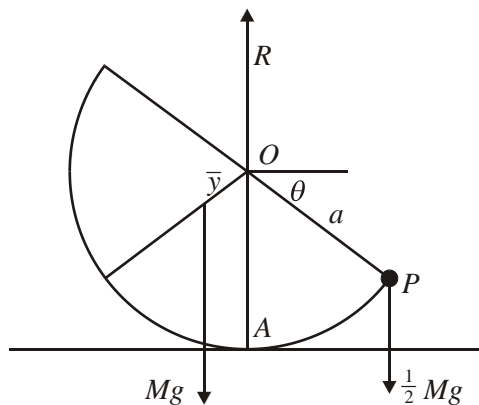

$$M(A) \quad Mg \times \frac{1}{3} a \sin \theta = \frac{1}{2} Mg \times a \cos \theta$$

M1 A1=A1

$$\tan \theta = \frac{3}{2}$$

M1

$$\theta \approx 56^\circ$$

caoA1

5

[9]

Methods involving the location of the combined centre of mass of  $C$  and  $P$ .

$G$  is the centre of mass of  $C$ ;  $G'$  is the combined centre of mass of  $C$  and  $P$ .

First Alternative

	$C$	$P$	$C$ and $P$
Mass ratios	2	1	3
$\bar{y}$	$\frac{1}{3}a$	0	$\bar{y}$
$\bar{x}$	0	$a$	$\bar{x}$

Finding both coordinates of  $G'$

M1

$$\frac{2}{3}a = 3\bar{y} \Rightarrow \bar{y} = \frac{2}{9}a$$

A1

$$a = 3\bar{x} \Rightarrow \bar{x} = \frac{1}{3}a$$

A1

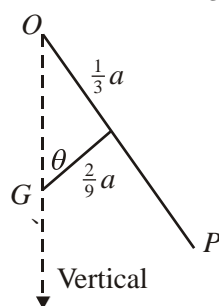

$$\tan \theta = \frac{\frac{1}{3}a}{\frac{2}{9}a} = \frac{3}{2}$$

M1

$$\theta \approx 56^\circ$$

cao A1 5



Second alternative

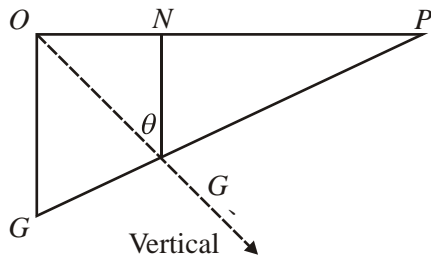

$$GG' : G'P = \frac{1}{2}M : M = 1 : 2$$

$$OG = \frac{1}{3}a, OP = a$$

By similar triangles

$$ON = \frac{1}{3}OP = \frac{1}{3}a$$

M1 A1

$$NG' = \frac{2}{3}OG = \frac{2}{9}a$$

A1

$$\tan \theta = \frac{ON}{NG'} = \frac{\frac{1}{3}a}{\frac{2}{9}a} = \frac{3}{2}$$

M1

$$\theta \approx 56^\circ$$

cao A1 5

13. (a)  $\frac{3r}{4}$  ;  $\frac{3r}{8}$

$$-m \cdot \frac{3r}{4} + M \cdot \frac{3r}{8} = (m + M)\bar{x}$$

$$\frac{3r(M - 2m)}{8(M + m)} = \bar{x} (*)$$

B1; B1

M1 A1

A1 5

(b)

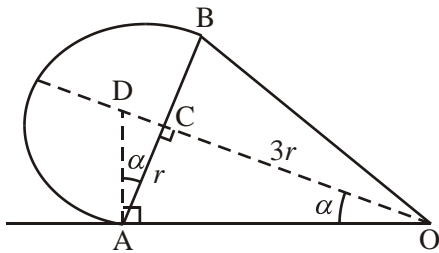

No equil<sup>m</sup>  $\Rightarrow \bar{x} \geq CD$

$$\frac{3r(M - 2m)}{8(M + m)} \geq \frac{r}{3}$$

$$9(M - 2m) > 8(M + m)$$

$$M > 26m (*)$$

M1

M1 A1

A1 c.s.o. 4

[9]

14. (a)

	Cylinder ( $36\pi r^3$ )	Cone ( $12\pi r^3$ )	Toy ( $48\pi r^3$ )	
mass ratio	3	1	4	B1
dist. from O	$2r$	$(-r)$	$\bar{x}$	B1
	$(3 \times 2r) - r = 4\bar{x}$			M1 A1
	$\frac{5r}{4} = \bar{x}$			A1 5

M1 for clear attempt at  $\Sigma mx = \bar{x} \Sigma m$  – correct no. of terms.  
If distances not measured from O, B1B1M1A1 available.

(b)

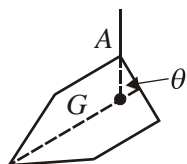

AG vertical, seen or implied

$$\tan \theta = \frac{3r}{4r - x}$$

$$\theta = 47.5^\circ \text{ (1 d.p.)}$$

second M1 for use of tan

M1

M1 A1

A1 4

(c)

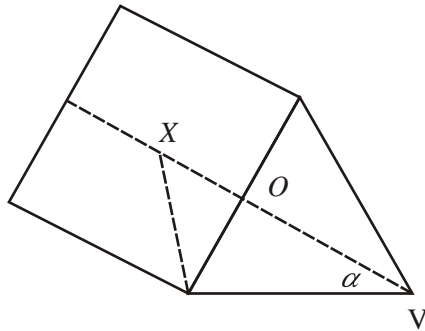

sim  $\Delta$ 's:  $\frac{OX}{3r} = \frac{3r}{4r} (= \tan \alpha)$  M1

$\Rightarrow OX = \frac{9r}{4}$  A1

$\bar{x} < OX$  M1

$\Rightarrow$  won't topple A1 c.s.o 4

*Note that second M1 is independent, for the general idea.*

[13]

15. (a)	Cylinder	Hemisphere	S	
Masses	$(\rho)\pi(2a)^2(\frac{3}{2}a)$	$(\rho)\frac{2}{3}\pi a^3$	$(\rho)(\frac{16}{3}\pi a^3)$	M1A1
	$[6\pi a^3]$			
	[18]	[2]	[16]	
	<i>[M1 for attempt at C, H and S = C - H masses]</i>			
Distances of CM from				
O	$\frac{3}{4}a$	$\frac{3}{8}a$	$\bar{x}$	B1B1
or lower face	$\frac{3}{4}a$	$\frac{a}{2} + \frac{5a}{8}$	$\bar{x}'$	
Moments equation: $6\pi a^3(\frac{3}{4}a) - \frac{2}{3}\pi a^3(\frac{3}{8}a) = \frac{16}{3}\pi a^3 \bar{x}$				M1
$\bar{x} = \frac{51}{64}a$				A1
(0.797a)				6

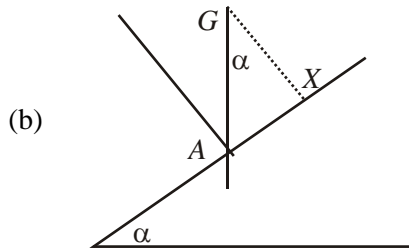

$G$  above “ $A$ ” seen or implied  
 or  $mg \sin \alpha (GX) = mg \cos \alpha (AX)$

M1

$$\tan \alpha = \frac{AX}{XG} = \frac{2a}{\frac{3}{2}a - \bar{x}}$$

M1

$$[GX = \frac{3}{2}a - \frac{51}{64}a = \frac{45}{64}a, \tan \alpha = \frac{128}{45}] \alpha = 70.6^\circ$$

A1

3

(c) Finding  $F$  and  $R$  :  $R = mg \cos \beta$ ,  $F = mg \sin \beta$   
 Using  $F = \mu R$  and finding  $\tan \beta$  [= 0.8]  
 $\beta = 38.7^\circ$

M1

M1

A1

3

[12]

16. (a)  $V = \pi \int y^2 dx$  [=  $\frac{1}{4} \pi \int (x-2)^4 dx$ ]

M1

$$\int (x-2)^4 dx = \frac{1}{5}(x-2)^5 \text{ or } [\frac{1}{5}x^5 - 2x^4 + 8x^3 - 16x^2 + 16x]$$

M1 A1

[M1 requires attempt to square and integrate]

$$V = \frac{8\pi}{5}$$

A1

4

(b) Using  $\pi \int xy^2 dx = [\frac{1}{4} \pi \int x(x-2)^4 dx$

M1

Correct strategy to integrate [e.g. substitution, expand, by parts]

M1

$$[\text{e.g. } \frac{1}{4} \pi \int (u-2)^4 du ; \frac{1}{4} \pi \int (x^5 - 8x^4 + 24x^3 - 32x^2 + 16x) dx];$$

$$= \frac{1}{4} \pi \left[ \frac{2u^5}{5} + \frac{u^6}{6} \right] \text{ or } \frac{1}{4} \pi \left[ \frac{x^6}{6} - \frac{8x^5}{5} + 6x^4 - \frac{32x^3}{3} + 8x^2 \right]$$

M1 A1

$$\text{Limits used correctly [correct values} = \frac{8\pi}{15}]$$

A1 ft

$$V_c(\rho) \bar{x} = \pi(\rho) \int xy^2 dx \text{ (seen anywhere)}$$

M1

$$\bar{x} = \frac{1}{3} \text{ cm (*) no incorrect working seen}$$

A1

7

(c) Moments equation to find C of M of tool:

e.g.  $12W\bar{x} = 10W \times 4 - 2W \times (\frac{1}{3})$  M1 A1 A1

(may be implied by next line) [ $\bar{x} = 3\frac{5}{18}$  from plane edge of S]

Moments about B:  $8R_A = 40W - 2W(\frac{1}{3})$

$$R_A = \frac{59W}{12} \text{ (4.9 W or 4.92W)} \quad \text{A1} \quad 5$$

[16]

[Moments about other points: M1 A1,  
Complete method to find  $R_A$  ; using  $R_A + R_B = 12W$  with  
moments equation M1 A1 ft; A1 as scheme]

17. (a) 

Cylinder	half-sphere	toy	
$\pi^2 h \rho$	$\frac{2}{3} \pi r^3 6 \rho$	$\pi r^2 h \rho + \frac{2}{3} \pi r^3 6 \rho$	M1 A1

$\frac{h}{2} + r$	$\frac{5r}{8}$	$d$	B1 B1
-------------------	----------------	-----	-------

$$\pi r^2 h \rho (\frac{h}{2} + r) + 4 \pi r^3 \rho \frac{5r}{8} = (\pi r^2 h \rho + 4 \pi r^3 \rho) d \quad \text{M1 A1}$$

$$\Rightarrow d = \frac{h^2 + 2rh + 5r^2}{2(h+4r)} \quad (*) \quad \text{A1} \quad 7$$

(b)  $d = r, \quad \Rightarrow h^2 + 2rh + 5r^2 = 2r(h + 4r)$  M1, M1

$$h = \sqrt{3}r \quad \text{A1} \quad 3$$

[10]

18. (a)

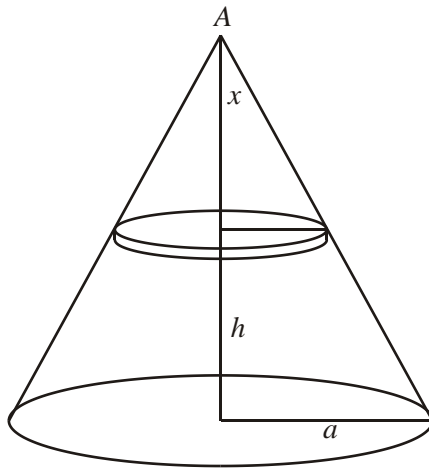

$$\text{Radius of element} = \frac{x}{h}a \quad \text{B1}$$

$$\frac{1}{3}\pi a^2 h \times \bar{x} = \frac{\pi a^2}{h^2} \left[ \frac{x^4}{4} \right]_0^h \quad \text{M1}$$

$$= \frac{\pi a^2 h^2}{4} \quad \text{M1}$$

$$\Rightarrow \bar{x} = \frac{3}{4}h \quad \text{A1} \quad 6$$

(b) Volume of large cone =  $\frac{1}{3}\pi a^2 h = V$

$$\text{Volume of small cone} = \frac{1}{3}\pi \times \frac{4a^2}{9} \times \frac{h}{2} = \frac{2}{9}V$$

$$\text{Volume of } S = \frac{7}{9}V$$

Volume	$V$	$\frac{2}{9}V$	$\frac{7}{9}V$	M1 A1
--------	-----	----------------	----------------	-------

CM from A	$\frac{3}{4}h$	$\frac{h}{2} + \frac{3}{4}\left(\frac{h}{2}\right)$	$\bar{x}$	B1 B1
-----------	----------------	---	-----------	-------

$$V \times \frac{3}{4}h - \frac{2}{9}V \left( \frac{7h}{8} \right) = \frac{7}{9}V \bar{x} \quad \text{M1 A1}$$

$$\Rightarrow \bar{x} = \frac{5h}{7} \quad \text{A1} \quad 7$$

[13]

1. This was a routine centre of mass problem requiring mass and associated known centre of mass for standard volumes, combined in an appropriate moments equation. A few mistakes occurred when candidates tried to write down their moments equation without detailing each part in a table. However the major difficulty was for those who couldn't produce a correct volume for the cone and occasionally even the cylinder. The cone had multiples of  $\frac{2}{3}$  and  $\frac{1}{4}$  used with  $\pi r^2 h$  and the cylinder became  $2\pi r^2 h$ . Some candidates failed to introduce the different value for  $r$  as  $l$  and  $2l$  before cancelling it hence giving an incorrect mass ratio.

In part (b), the condition for tipping with  $G$  above the bottom point on the container, was used by all who attempted this part. Recognising the use of  $6l - (\text{their } x)$  was crucial to finding a correct trigonometric ratio, and those that did made few mistakes finding  $\theta$  correctly. As expected a few used  $l$  instead of  $2l$  in the numerator for their expression for  $\tan\theta$ .

2. The majority of candidates could complete, or nearly complete, part (a) successfully. The given answer did allow some candidates to correct their arithmetic errors. Those who reduced their 3 volumes to a ratio (8:19:27) before constructing the moments equation produced clearer and more straightforward solutions than those who worked with the original volume formulae. A few candidates remembered their GCSE work on the ratio of volumes of similar solids and stated directly that the ratio of the two hemispheres was 8:27.

Part (b) was done very quickly and easily by the most able candidates but proved difficult for the majority. Many candidates proceeded straight from Q3(a) to Q4. Of those who attempted part (b), there was a fairly even split between those who took moments about the vertical through  $O$  for the two weights (or mentally cancelled  $g$  and used masses) and those who found the coordinates of the centre of mass of the composite body. Some of the latter group found only one coordinate and others made an error in their calculations. Some of the former group produced a moments equation with trigonometrical ratios that cancelled. Since this made the given information that  $\tan\theta = \frac{4}{5}$  redundant, they should have been alerted to their mistake.

3. This question produced many completely correct solutions. Some candidates however ignored the information provided about the masses of the two parts of the route marker and calculated their own "masses" by using volumes instead, usually assuming both sections to be solids. Almost all could produce a valid, if not correct, moments equation and so gained some marks. The most frequently seen error in part (b) was to have the required fraction upside down resulting in  $h = \frac{r}{24}$ . Some candidates lost the final mark here through giving  $r$  in terms of  $h$  instead of answering the question asked.

4. Solutions to this question were spoilt by poor integration;  $\int x^{-4} dx$  was seen as  $x^{-5}$ ,  $x^{-3}$ ,  $-3x^{-3}$  and even  $\ln(x^4)$ . Many marks were lost by candidates who were determined to arrive at the given answer of  $21\pi$  even though their working could not support this result. A large number of good candidates lost the final mark in part (b) as they completely forgot that *coordinates* had been requested and so a  $y$ -coordinate was needed as well as the  $x$ -coordinate. Other errors in part (b) included finding the centre of mass of a lamina, ignoring the volume found in (a), and various further integration mistakes. There was some confusion over the significance of the lower limit for  $x$  being  $\frac{1}{4}$ ; some candidates seemed to think it was necessary to subtract  $\frac{1}{4}$  from their result.
5. Part (a) was a standard solution quoted correctly using two integrals. The majority could handle the pure maths successfully. This part could be worked correctly without including  $\pi$  in either integral as it clearly cancels. However, this led some candidates to omit  $\pi$  when calculating the mass/volume of  $S$  in (b). Many candidates seemed to not know what approach to take in (b) and so made no attempt at all. Of those who attempted this part, most took moments about the join but every possible mistake concerning volumes and distances was seen. Some took moments about the centre of the plane face of the cylinder, not always remembering to recalculate the lengths involved or use the volume of the total solid.
6. Centres of mass were well understood and, apart from the initial formulations for volumes of hemispheres, a large number of candidates had fully correct solutions to parts (a) and (b). A few did not know the formula for the volume of a sphere and a few forgot to divide by two. The latter group obtained a correct answer for (a) (but scored only 4/5). However, their error was exposed in (b) as they could not obtain the given answer here. A few went back and found and corrected their error; others gave up or fudged the answer. Weaker candidates sometimes omitted part (c). Several methods for part (c) were seen – the most common were finding the critical angle and finding the point at which the vertical through the centre of mass cut the plane, showing that the distance from the axis of symmetry was less than  $2a$ . A small number had the plane face of the hemisphere on the plane and a few thought that the answer to (b) was the distance of the centre of mass from the plane.



7. This question was, on the whole, well done with a great many candidates gaining full marks. Part (a) caused more problems than part (b) but many candidates who had difficulty with (a) went on to complete (b) successfully. There were a significant number of very weak attempts at (a) which tried to involve integration, often apparently trying to prove the result for the centre of mass of a cone. Among successful solutions, the most popular method was to treat the container as a cylinder without ends and combine this with one circular end. However the alternative involving the removal of a lid from a container closed at both ends was also quite common and was usually successful. Problems with (b) were rare and tended to arise only where candidates attempted to consider the curved surface, base and liquid as three separate items, ignoring the given  $M$  and often taking the masses as  $2\pi h^2$ ,  $\pi h^2$  and  $\pi h^3$ . Some, however, completed this method successfully by using the mass of the liquid as  $3\pi h^2$ . Geometrical solutions to either part of the question were uncommon.
8. The principles here were generally well known. Mistakes occurred in part (a) with the accuracy of the integration concerned, several dropping factors involving the fractions. And in part (b), a number of candidates failed to realise that the integral they had calculated in part (a) was not necessarily the mass of the solid (especially when they had cancelled out a factor earlier).
9. This question proved to be, for the great majority, a test of memory. Those who could remember the correct formula for the centre of mass of a solid of revolution almost always gained full marks and those who could not gained very little. Very few candidates used the idea of breaking the solid up into elementary discs either as a method of demonstrating the formula or of checking that they had remembered the formula correctly.
10. Part (a) was very well done and full marks were common. The best and clearest solutions reduced the masses to the ratio  $8 : 1 : 7$  before starting the calculation for the centre of mass and it may be a good policy to encourage candidates to remove densities, radii and  $\pi$ s before they write down their moments equation. Part (b) proved more difficult but many completely correct solutions were seen. A common error was to fail to make the connection with part (a) and take the centre of mass of the bowl as being  $\frac{3}{8} a$  from the surface of the liquid. Another source of error was including volumes in the mass ratios which, in this part, are simply  $1 : k : k + 1$ .
11. This provided a very easy nine marks for many and almost all knew what they were trying to do. The most frequent mistake in (a) was to assume that volumes needed to be used for the cylinder and hemisphere and in (b) the fraction was often upside down. Where solutions did go wrong, there was again widespread fiddling. Even the volume versions sometimes ended up being rearranged, factorised or cancelled into the required expression.

12. Part (a) was generally well done and the majority of those who could not obtain the printed answer usually failed through lack of knowledge of the formula for the surface area of the sphere. This formula is given in the Formula Booklet and candidates in Mechanics are expected to be familiar with, or know where to look for, Pure (or Core) Mathematics formulae which are appropriate to a Mechanics module. Part (b) was generally poorly done. Many candidates were unable to visualise the situation and, after a few attempts to draw a diagram, abandoned the question. The simplest solution is to take moments about the point of contact with the floor or about the centre of the plane face of the hemisphere but this was rarely seen. The most successful candidates tended to be those who worked out the position of the centre of mass of the hemisphere and particle combined, even though this involved more work.
13. The first part was generally well done, although some candidates tried to introduce volumes into their calculations but there were very few fully correct solutions to part (b), where a good diagram was essential.
14. This question was generally very well answered with many fully correct solutions to parts (a) and (b). A pleasing number of candidates also were successful in presenting a logical solution to part (c). Only the weakest candidates found the question inaccessible and scored fewer than half marks. The most common error in part (a) was inconsistent use of  $r$  - some candidates being confused with radius as used in the volume formulae and the use of  $r$  in the question. This led to inconsistent algebraic equations that proved impossible to simplify and solve. The most common error in part (b) was finding the complement of the required angle or not stating the answer to the required degree of accuracy. Part (c) proved difficult for many candidates - common errors were using  $3r/2$  as the radius of the base of the cone/cylinder and assuming the slant length of the cone to be  $4r$ . Correct results for two angles were often calculated but the relationship between them was not sufficiently explained for full marks to be awarded. The most satisfactory solutions involved proving that the line of action of the weight passed through the slant side of the cone or that the sum of the base angle of the cone and the angle from O to the edge of the cone/cylinder interface to G was less than 90 degrees.
15. The vast majority of candidates knew what was required in this question, which was generally a source of high marks.

16. In part (a) the majority of candidates were able to recognise and use the formula for the volume of revolution. The most common approach to finding  $\int (x - 2)^4 dx$  was to multiply out the brackets, which will have taken up precious time and was often incorrect.

Problems arose with the nature of the given equation, with many candidates not squaring the squared factor, so that  $\frac{1}{4} \pi \int (x - 2)^2 dx$  was often seen, even after  $\pi \int y^2 dx$  had previously been quoted. Also, there were as many candidates who used 0 and 1 as the limits of integration as there were who used the correct values of 0 and 2; presumably triggered by the given statement that “The unit of length on both axes is 1 cm”. If this was the only mistake, candidates only lost two marks for this misunderstanding.

Although there were many very good solutions to this question, part (b) did cause problems. It may be that at this stage weaker candidates were rushed and did not read the question well enough as errors such as using  $\int xy dx$ , not squaring  $y$ , and poor integration were common.

In part (c) many candidates made the question more unwieldy by working with their own weights rather than using the given weights for  $S$  and  $C$ , and it was surprising to see so many candidates finding the centre of mass of the tool on route to answering the question. However, most candidates were able to gain some credit in this part.

17. The correct method was well known in the first part and the majority were able to obtain the printed answer. Common errors were to omit or interchange the densities, use an incorrect volume formula or to measure a distance from a wrong point. There was less success with part (b) where a significant number of candidates did not know where to start.

18. No Report available for this question.