

OCR

Oxford Cambridge and RSA

Wednesday 18 May 2016 – Morning

A2 GCE MATHEMATICS (MEI)

4762/01 Mechanics 2

QUESTION PAPER

Candidates answer on the Printed Answer Book.

OCR supplied materials:

- Printed Answer Book 4762/01
- MEI Examination Formulae and Tables (MF2)

Other materials required:

- Scientific or graphical calculator

Duration: 1 hour 30 minutes



INSTRUCTIONS TO CANDIDATES

These instructions are the same on the Printed Answer Book and the Question Paper.

- The Question Paper will be found inside the Printed Answer Book.
- Write your name, centre number and candidate number in the spaces provided on the Printed Answer Book. Please write clearly and in capital letters.
- **Write your answer to each question in the space provided in the Printed Answer Book.** Additional paper may be used if necessary but you must clearly show your candidate number, centre number and question number(s).
- Use black ink. HB pencil may be used for graphs and diagrams only.
- Read each question carefully. Make sure you know what you have to do before starting your answer.
- Answer **all** the questions.
- Do **not** write in the bar codes.
- You are permitted to use a scientific or graphical calculator in this paper.
- Final answers should be given to a degree of accuracy appropriate to the context.
- The acceleration due to gravity is denoted by $g \text{ m s}^{-2}$. Unless otherwise instructed, when a numerical value is needed, use $g = 9.8$.

INFORMATION FOR CANDIDATES

This information is the same on the Printed Answer Book and the Question Paper.

- The number of marks is given in brackets [] at the end of each question or part question on the Question Paper.
- You are advised that an answer may receive **no marks** unless you show sufficient detail of the working to indicate that a correct method is being used.
- The total number of marks for this paper is **72**.
- The Printed Answer Book consists of **16** pages. The Question Paper consists of **8** pages. Any blank pages are indicated.

INSTRUCTION TO EXAMS OFFICER/INVIGILATOR

- Do not send this Question Paper for marking; it should be retained in the centre or recycled. Please contact OCR Copyright should you wish to re-use this document.

- 1 (a) Two model railway trucks are moving freely on a straight horizontal track when they are in a direct collision.

The trucks are P of mass 0.5 kg and Q of mass 0.75 kg. They are initially travelling in the same direction. Just before they collide P has a speed of 4 m s^{-1} and Q has a speed of 1 m s^{-1} , as shown in Fig. 1.1.

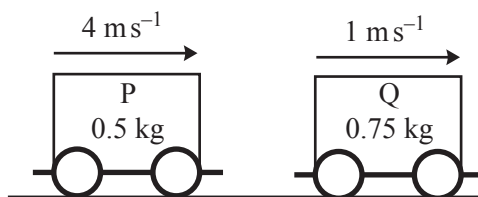

Fig. 1.1

- (i) Suppose that the speed of P is halved in the collision and that its direction of motion is not changed. Find the speed of Q immediately after the collision and find the coefficient of restitution. [5]
- (ii) Show that it is not possible for both the speed of P to be halved in the collision and its direction of motion to be reversed. [3]

Both of the model trucks have flat horizontal tops. They are each travelling at the speeds they had immediately after the collision.

Part of the mass of Q is a small object of mass 0.1 kg at rest at the edge of the top of Q nearest P. The object falls off, initially with negligible velocity relative to Q.

- (iii) Determine the speed of Q immediately after the object falls off it, making your reasoning clear. [2]

Part of the mass of P is an object of mass 0.05 kg that is fired horizontally from the top of P, parallel to and in the opposite direction to the motion of P. Immediately after the object is fired, it has a speed of 10 m s^{-1} relative to P.

- (iv) Determine the speed of P immediately after the object has been fired from it. [4]

- (b) The velocities of a small object immediately before and after an elastic collision with a horizontal plane are shown in Fig. 1.2.

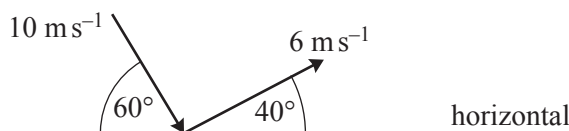

Fig. 1.2

Show that the plane cannot be smooth. [3]

- 2 (a) A bullet of mass 0.04 kg is fired into a fixed uniform rectangular block along a line through the centres of opposite parallel faces, as shown in Fig. 2.1.

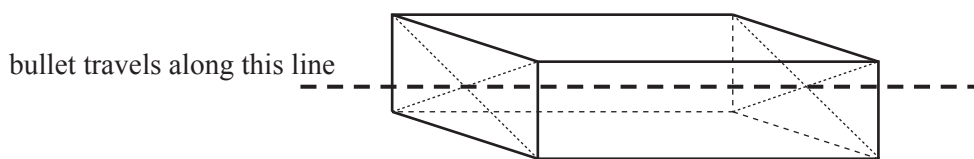

Fig. 2.1

The bullet enters the block at 50 m s^{-1} and comes to rest after travelling 0.2 m into the block.

- (i) Calculate the resistive force on the bullet, assuming that this force is constant. [3]

Another bullet of the same mass is fired, as before, with the same speed into a similar block of mass 3.96 kg . The block is initially at rest and is free to slide on a smooth horizontal plane.

- (ii) By considering linear momentum, find the speed of the block with the bullet embedded in it and at rest relative to the block. [2]
- (iii) By considering mechanical energy, find the distance the bullet penetrates the block, given the resistance of the block to the motion of the bullet is the same as in part (i). [4]

- (b) Fig. 2.2 shows a block of mass 6 kg on a uniformly rough plane that is inclined at 30° to the horizontal.

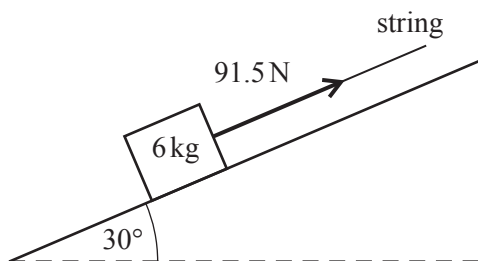

Fig. 2.2

A string with a constant tension of 91.5 N parallel to the plane pulls the block up a line of greatest slope. The speed of the block increases from 1 m s^{-1} to 7 m s^{-1} over a distance of 8 m .

- (i) Use an energy method to find the magnitude of the frictional force acting on the block.
Calculate the coefficient of friction between the block and the plane. [8]
- (ii) Calculate the power of the tension in the string when the block has a speed of 7 m s^{-1} . [2]

- 3 Fig. 3.1 shows a thin planar uniform rigid rectangular sheet of metal, OPQR, of width 1.65 m and height 1.2 m. The mass of the sheet is M kg. The sides OP and PQ have thin rigid uniform reinforcements attached with masses $0.6M$ kg and $0.4M$ kg, respectively. Fig. 3.1 also shows coordinate axes with origin at O.

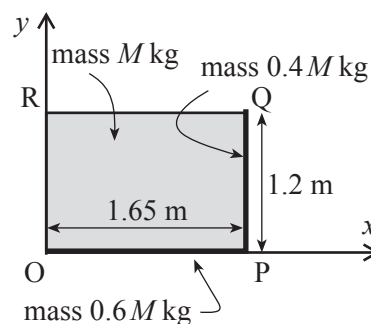

Fig. 3.1

The sheet with its reinforcements is to be used as an inn sign.

- (i) Calculate the coordinates of the centre of mass of the inn sign. [4]

The inn sign has a weight of 300 N. It hangs in equilibrium with QR horizontal when vertical forces Y_Q N and Y_R N act at Q and R respectively.

- (ii) Calculate the value of Y_Q and show that $Y_R = 120$. [3]

The inn sign is hung from a framework, ABCD, by means of two light vertical inextensible wires attached to the sign at Q and R and the framework at B and C, as shown in Fig. 3.2. QR and BC are horizontal. The framework is made from light rigid rods AB, BC, CA and CD freely pin-jointed together at A, B and C and to a vertical wall at A and D. Fig. 3.3 shows the dimensions of the framework in metres as well as the external forces X_A N, Y_A N acting at A and X_D N, Y_D N acting at D.

You are given that $\sin \alpha = \frac{5}{13}$, $\cos \alpha = \frac{12}{13}$, $\sin \beta = \frac{4}{5}$ and $\cos \beta = \frac{3}{5}$.

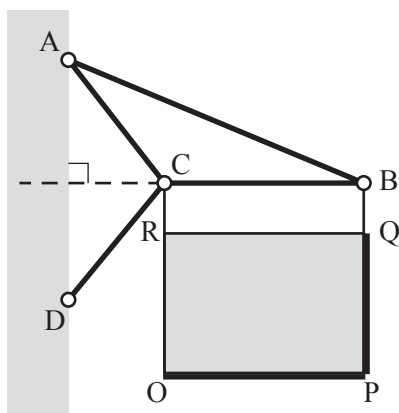

Fig. 3.2

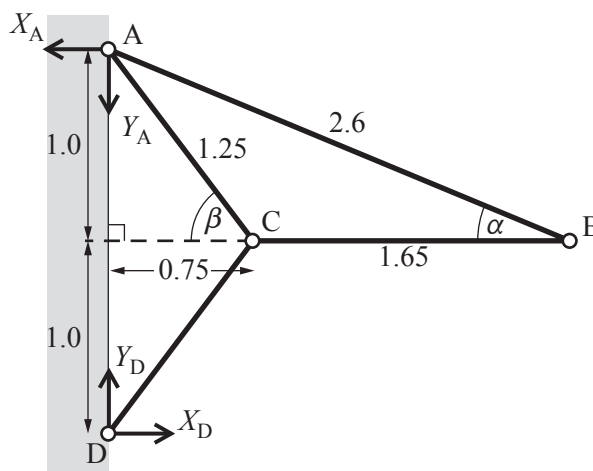

Fig. 3.3

- (iii) Mark on the diagram in your Printed Answer Book all the forces acting on the pin-joints at A, B, C and D, including those internal to the rods, when the inn sign is hanging from the framework. [1]
- (iv) Show that $X_D = 261$. [2]
- (v) Calculate the forces internal to the rods AB, BC and CD, stating whether each rod is in tension or thrust (compression). Calculate also the values of Y_D and Y_A . [Your working in this part should correspond to your diagram in part (iii).] [8]

- 4 Fig. 4.1 shows a hollow circular cylinder open at one end and closed at the other. The radius of the cylinder is 0.1 m and its height is h m. O and C are points on the axis of symmetry at the centres of the open and closed ends, respectively. The thin material used for the closed end has four times the density of the thin material used for the curved surface.

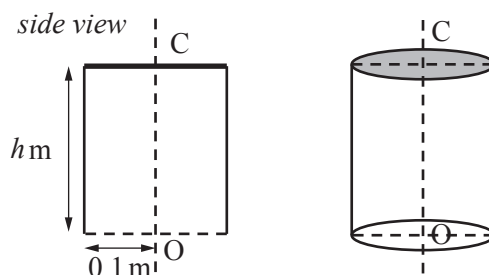

Fig. 4.1

Cylinders of this type are made with different values of h .

- (i) Show that the centres of mass of these cylinders are on the line OC at a distance $\frac{5h^2 + 2h}{2 + 10h}$ m from O. [6]

Fig. 4.2 shows one of the cylinders placed with its open end on a slope inclined at an angle α to the horizontal, where $\tan \alpha = \frac{2}{3}$. The cylinder does not slip but is on the point of tipping.

- (ii) Show that $50h^2 + 5h - 3 = 0$ and hence that $h = 0.2$. [7]

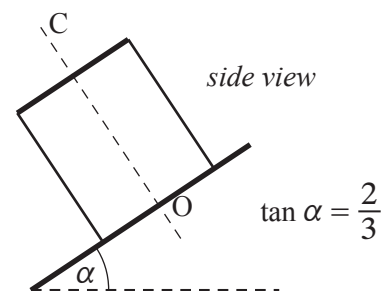

Fig. 4.2

Fig. 4.3 shows another of the cylinders that has weight 42 N and $h = 0.5$. This cylinder has its open end on a rough horizontal plane. A force of magnitude T N is applied to a point P on the circumference of the closed end. This force is at an angle β with the horizontal such that $\tan \beta = \frac{3}{4}$ and the force is in the vertical plane containing O, C and P. The cylinder does not slip but is on the point of tipping.

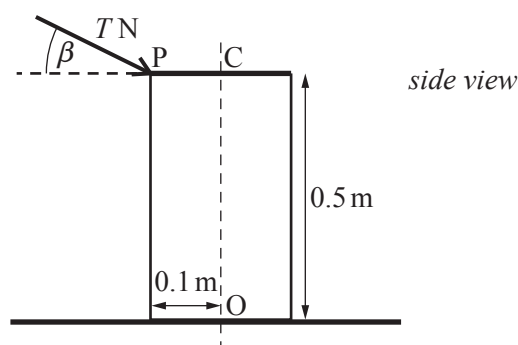

Fig. 4.3

- (iii) Calculate T .

[5]

END OF QUESTION PAPER

BLANK PAGE

BLANK PAGE

**Copyright Information**

OCR is committed to seeking permission to reproduce all third-party content that it uses in its assessment materials. OCR has attempted to identify and contact all copyright holders whose work is used in this paper. To avoid the issue of disclosure of answer-related information to candidates, all copyright acknowledgements are reproduced in the OCR Copyright Acknowledgements Booklet. This is produced for each series of examinations and is freely available to download from our public website (www.ocr.org.uk) after the live examination series.

If OCR has unwittingly failed to correctly acknowledge or clear any third-party content in this assessment material, OCR will be happy to correct its mistake at the earliest possible opportunity.

For queries or further information please contact the Copyright Team, First Floor, 9 Hills Road, Cambridge CB2 1GE.

OCR is part of the Cambridge Assessment Group; Cambridge Assessment is the brand name of University of Cambridge Local Examinations Syndicate (UCLES), which is itself a department of the University of Cambridge.