

Paper Reference(s)

6678/01**Edexcel GCE****Mechanics M2****Silver Level S1****Time: 1 hour 30 minutes****Materials required for examination**

Mathematical Formulae (Green)

Items included with question papers

Nil

Candidates may use any calculator allowed by the regulations of the Joint Council for Qualifications. Calculators must not have the facility for symbolic algebra manipulation, differentiation and integration, or have retrievable mathematical formulas stored in them.

Instructions to Candidates

In the boxes on the answer book, write the name of the examining body (Edexcel), your centre number, candidate number, the unit title (Mechanics M2), the paper reference (6678), your surname, other name and signature.

Whenever a numerical value of g is required, take $g = 9.8 \text{ m s}^{-2}$.

When a calculator is used, the answer should be given to an appropriate degree of accuracy.

Information for Candidates

A booklet 'Mathematical Formulae and Statistical Tables' is provided.

Full marks may be obtained for answers to ALL questions.

There are 7 questions in this question paper. The total mark for this paper is 75.

Advice to Candidates

You must ensure that your answers to parts of questions are clearly labelled.

You must show sufficient working to make your methods clear to the Examiner. Answers without working may gain no credit.

Suggested grade boundaries for this paper:

A*	A	B	C	D	E
70	63	52	42	33	25

1. A car of mass 1000 kg moves with constant speed $V \text{ m s}^{-1}$ up a straight road inclined at an angle θ to the horizontal, where $\sin \theta = \frac{1}{30}$. The engine of the car is working at a rate of 12 kW. The resistance to motion from non-gravitational forces has magnitude 500 N.

Find the value of V .

(5)

2. At time t seconds ($t \geq 0$), a particle P has position vector \mathbf{p} metres, with respect to a fixed origin O , where

$$\mathbf{p} = (3t^2 - 6t + 4)\mathbf{i} + (3t^3 - 4t)\mathbf{j}.$$

Find

- (a) the velocity of P at time t seconds,

(2)

- (b) the value of t when P is moving parallel to the vector \mathbf{i} .

(3)

When $t = 1$, the particle P receives an impulse of $(2\mathbf{i} - 6\mathbf{j}) \text{ N s}$. Given that the mass of P is 0.5 kg,

- (c) find the velocity of P immediately after the impulse.

(4)

3. A block of mass 10 kg is pulled along a straight horizontal road by a constant horizontal force of magnitude 70 N in the direction of the road. The block moves in a straight line passing through two points A and B on the road, where $AB = 50 \text{ m}$. The block is modelled as a particle and the road is modelled as a rough plane. The coefficient of friction between the block and the road is $\frac{4}{7}$.

- (a) Calculate the work done against friction in moving the block from A to B .

(4)

The block passes through A with a speed of 2 m s^{-1} .

- (b) Find the speed of the block at B .

(4)

4.

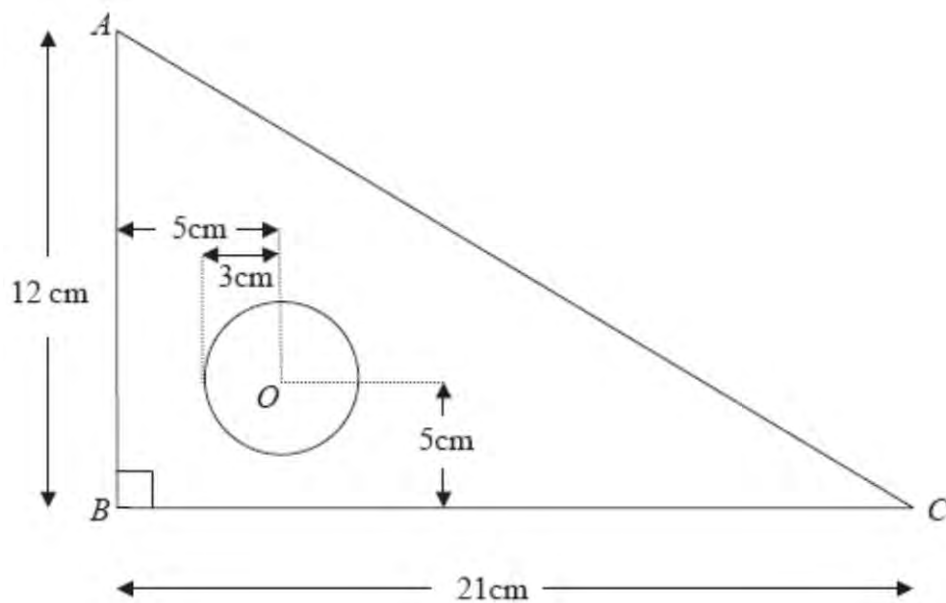

Figure 1

A set square S is made by removing a circle of centre O and radius 3 cm from a triangular piece of wood. The piece of wood is modelled as a uniform triangular lamina ABC , with $\angle ABC = 90^\circ$, $AB = 12$ cm and $BC = 21$ cm. The point O is 5 cm from AB and 5 cm from BC , as shown in Figure 1.

(a) Find the distance of the centre of mass of S from

(i) AB ,

(ii) BC .

(9)

The set square is freely suspended from C and hangs in equilibrium.

(b) Find, to the nearest degree, the angle between CB and the vertical.

(3)

5.

Figure 3

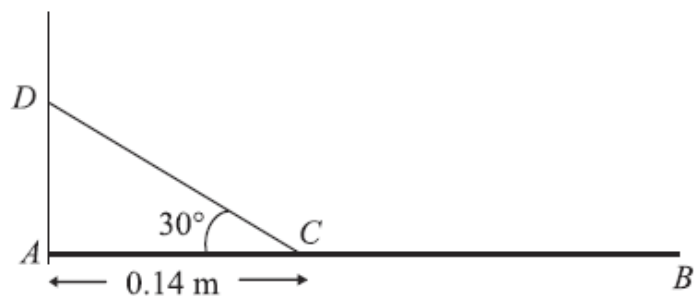

A uniform beam AB of mass 2 kg is freely hinged at one end A to a vertical wall. The beam is held in equilibrium in a horizontal position by a rope which is attached to a point C on the beam, where $AC = 0.14$ m. The rope is attached to the point D on the wall vertically above A , where $\angle ACD = 30^\circ$, as shown in Figure 3. The beam is modelled as a uniform rod and the rope as a light inextensible string. The tension in the rope is 63 N.

Find

(a) the length of AB , (4)

(b) the magnitude of the resultant reaction of the hinge on the beam at A . (5)

6.

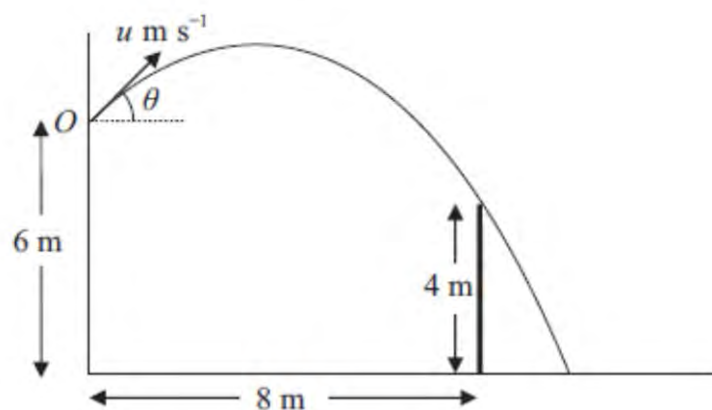

Figure 2

A ball is thrown from a point O , which is 6 m above horizontal ground. The ball is projected with speed $u \text{ m s}^{-1}$ at an angle θ above the horizontal. There is a thin vertical post which is 4 m high and 8 m horizontally away from the vertical through O , as shown in Figure 2. The ball passes just above the top of the post 2 s after projection. The ball is modelled as a particle.

(a) Show that $\tan \theta = 2.2$. (5)

(b) Find the value of u . (2)

The ball hits the ground T seconds after projection.

(c) Find the value of T . (3)

Immediately before the ball hits the ground the direction of motion of the ball makes an angle α with the horizontal.

(d) Find α . (5)

7. A particle P of mass $2m$ is moving with speed $2u$ in a straight line on a smooth horizontal plane. A particle Q of mass $3m$ is moving with speed u in the same direction as P . The particles collide directly. The coefficient of restitution between P and Q is $\frac{1}{2}$.

(a) Show that the speed of Q immediately after the collision is $\frac{8}{5}u$. (5)

(b) Find the total kinetic energy lost in the collision. (5)

After the collision between P and Q , the particle Q collides directly with a particle R of mass m which is at rest on the plane. The coefficient of restitution between Q and R is e .

(c) Calculate the range of values of e for which there will be a second collision between P and Q . (7)

TOTAL FOR PAPER: 75 MARKS

END

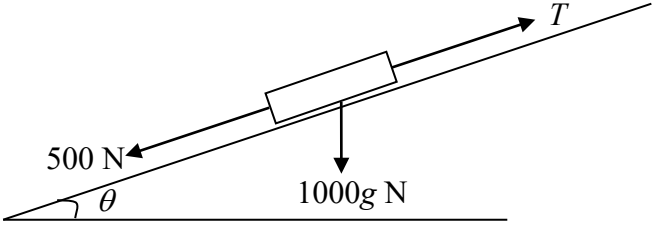
Question Number	Scheme	Marks
1.	 <p> $12000 = TV$ $T - 500 - 1000g \sin \theta = 0$ $V = \frac{12000}{500 + 1000 \times 9.8 \times \frac{1}{30}}$ $V = 15$ (accept 14.5) </p>	<p>M1 M1 A1 DM1 A1</p> <p>(5) 5</p>
2.	<p>(a) $\dot{\mathbf{p}} = (6t - 6)\mathbf{i} + (9t^2 - 4)\mathbf{j}$ (ms^{-1})</p> <p>(b) $9t^2 - 4 = 0$ $t = \frac{2}{3}$</p> <p>(c) $t = 1 \Rightarrow \dot{\mathbf{p}} = 5\mathbf{j}$ ft their \dot{p} $(+/-) 2\mathbf{i} - 6\mathbf{j} = 0.5(\mathbf{v} - 5\mathbf{j})$ $\mathbf{v} = 4\mathbf{i} - 7\mathbf{j}$ (ms^{-1})</p>	<p>M1 A1 (2)</p> <p>M1 DM1 A1 (3)</p> <p>B1ft M1 M1 A1 (4) [9]</p>

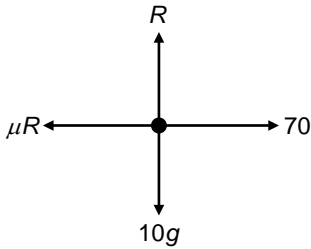
Question Number	Scheme	Marks																																																																		
<p>3 (a)</p> 	$R(\uparrow) : R = 10g$ $F = \mu R \Rightarrow F = \frac{4}{7}(10g) = 56$ $\therefore \text{WD against friction} = \frac{4}{7}(10g)(50)$ $2800(\text{J})$ <p>(b) $70(50) - "2800" = \frac{1}{2}(10)v^2 - \frac{1}{2}(10)(2)^2$</p> $700 = 5v^2 - 20, \quad 5v^2 = 720 \Rightarrow v^2 = 144$ <p>Hence, $v = \underline{12}$ (m s^{-1})</p>	<p>B1</p> <p>B1</p> <p>M1</p> <p>A1</p> <p>(4)</p> <p>M1*</p> <p>A1ft</p> <p>d*M1</p> <p>A1 cao</p> <p>(4)</p> <p>[8]</p>																																																																		
<p>4.</p>	<table border="0" style="width: 100%; border-collapse: collapse;"> <tr> <td style="width: 15%;"></td> <td style="width: 15%; text-align: center;">(a)</td> <td style="width: 15%; text-align: center;">Triangle</td> <td style="width: 15%; text-align: center;">Circle</td> <td style="width: 15%; text-align: center;">S</td> <td style="width: 20%;"></td> </tr> <tr> <td></td> <td style="text-align: center;">Mass ratio</td> <td style="text-align: center;">126</td> <td style="text-align: center;">9π</td> <td style="text-align: center;">$126 - 9\pi$</td> <td></td> </tr> <tr> <td></td> <td></td> <td></td> <td style="text-align: center; color: red;">(28.3)</td> <td style="text-align: center; color: red;">(97.7)</td> <td></td> </tr> <tr> <td></td> <td style="text-align: center;">\bar{x}</td> <td style="text-align: center;">7</td> <td style="text-align: center;">5</td> <td style="text-align: center;">\bar{x}</td> <td></td> </tr> <tr> <td></td> <td style="text-align: center;">\bar{y}</td> <td style="text-align: center;">4</td> <td style="text-align: center;">5</td> <td style="text-align: center;">\bar{y}</td> <td style="text-align: center;">4, 7 seen</td> </tr> <tr> <td></td> <td></td> <td colspan="3" style="text-align: center;">$126 \times 7 = 9\pi \times 5 + (126 - 9\pi) \times \bar{x}$ ft their table values</td> <td></td> </tr> <tr> <td></td> <td></td> <td colspan="3" style="text-align: center;">$\bar{x} \approx 7.58 \left(\frac{882 - 45\pi}{126 - 9\pi} \right)$ awrt 7.6</td> <td></td> </tr> <tr> <td></td> <td></td> <td colspan="3" style="text-align: center;">$126 \times 4 = 9\pi \times 5 + (126 - 9\pi) \times \bar{y}$ ft their table values</td> <td></td> </tr> <tr> <td></td> <td></td> <td colspan="3" style="text-align: center;">$\bar{y} \approx 3.71 \left(\frac{504 - 45\pi}{126 - 9\pi} \right)$ awrt 3.7</td> <td></td> </tr> <tr> <td></td> <td style="text-align: center;">(b)</td> <td colspan="3" style="text-align: center;">$\tan \theta = \frac{\bar{y}}{21 - \bar{x}}$</td> <td style="text-align: center;">ft their \bar{x}, \bar{y}</td> </tr> <tr> <td></td> <td></td> <td colspan="3" style="text-align: center;">$\theta \approx 15^\circ$</td> <td></td> </tr> </table>		(a)	Triangle	Circle	S			Mass ratio	126	9π	$126 - 9\pi$					(28.3)	(97.7)			\bar{x}	7	5	\bar{x}			\bar{y}	4	5	\bar{y}	4, 7 seen			$126 \times 7 = 9\pi \times 5 + (126 - 9\pi) \times \bar{x}$ ft their table values						$\bar{x} \approx 7.58 \left(\frac{882 - 45\pi}{126 - 9\pi} \right)$ awrt 7.6						$126 \times 4 = 9\pi \times 5 + (126 - 9\pi) \times \bar{y}$ ft their table values						$\bar{y} \approx 3.71 \left(\frac{504 - 45\pi}{126 - 9\pi} \right)$ awrt 3.7					(b)	$\tan \theta = \frac{\bar{y}}{21 - \bar{x}}$			ft their \bar{x}, \bar{y}			$\theta \approx 15^\circ$				<p>B1 B1ft</p> <p>B1</p> <p>M1 A1ft</p> <p>A1</p> <p>M1 A1ft</p> <p>A1</p> <p>(9)</p> <p>M1 A1ft</p> <p>A1</p> <p>(3)</p> <p>[12]</p>
	(a)	Triangle	Circle	S																																																																
	Mass ratio	126	9π	$126 - 9\pi$																																																																
			(28.3)	(97.7)																																																																
	\bar{x}	7	5	\bar{x}																																																																
	\bar{y}	4	5	\bar{y}	4, 7 seen																																																															
		$126 \times 7 = 9\pi \times 5 + (126 - 9\pi) \times \bar{x}$ ft their table values																																																																		
		$\bar{x} \approx 7.58 \left(\frac{882 - 45\pi}{126 - 9\pi} \right)$ awrt 7.6																																																																		
		$126 \times 4 = 9\pi \times 5 + (126 - 9\pi) \times \bar{y}$ ft their table values																																																																		
		$\bar{y} \approx 3.71 \left(\frac{504 - 45\pi}{126 - 9\pi} \right)$ awrt 3.7																																																																		
	(b)	$\tan \theta = \frac{\bar{y}}{21 - \bar{x}}$			ft their \bar{x}, \bar{y}																																																															
		$\theta \approx 15^\circ$																																																																		

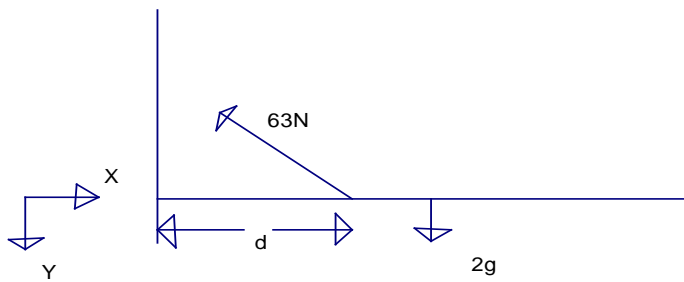
Question Number	Scheme	Marks
5.(a)	 <p> $M(A) \quad 63 \sin 30 \cdot 14 = 2g \cdot d$ Solve: $d = 0.225\text{m}$ Hence $AB = \underline{45 \text{ cm}}$ </p>	M1 A1 A1 A1 (4)
(b)	<p> $R(\rightarrow) \quad X = 63 \cos 30 \ (\approx 54.56)$ $R(\uparrow) \quad Y = 63 \sin 30 - 2g \ (\approx 11.9)$ $R = \sqrt{(X^2 + Y^2)} \approx \underline{55.8, 55.9 \text{ or } 56 \text{ N}}$ </p>	B1 M1 A1 M1 A1 (5)

Question Number	Scheme	Marks
6 (a)	$2 = -2u \sin \theta + \frac{1}{2}g \times 4$ $\left(-2 = u \sin \theta t - \frac{1}{2}gt^2\right)$ $u \sin \theta = g - 1$ $2u \cos \theta = 8 \quad (u \cos \theta = 4)$ $(u \cos \theta = 8)$ $\tan \theta = \frac{g-1}{4} = 2.2 \quad *$	<p>M1</p> <p>A1</p> <p>B1</p> <p>M1 A1</p>
(b)	$u \cos \theta = 4$ $u = \frac{4}{\cos \theta} = 9.66... = 9.7$ <p>OR use components from (a) and Pythagoras.</p>	<p>M1</p> <p>A1</p>
(c)	$6 = (1 - g)T + \frac{1}{2} \times 9.8T^2$ $4.9T^2 - 8.8T - 6 = 0$ $T = \frac{8.8 \pm \sqrt{[(-)8.8]^2 + 24 \times 4.9}}{9.8}$ $T = 2.323... = 2.32 \quad \text{or} \quad 2.3$	<p>M1</p> <p>M1</p> <p>A1</p>
(d)	$v^2 = 8.8^2 + 2g \times 6 \quad \text{or} \quad v = -8.8 + gT$ $v = 13.96$ <p>Horiz speed = 4</p> $\tan \alpha = \frac{v}{4}$ $\alpha = 74.01... = 74^\circ$	<p>M1</p> <p>A1</p> <p>M1</p> <p>A1</p> <p>A1</p>

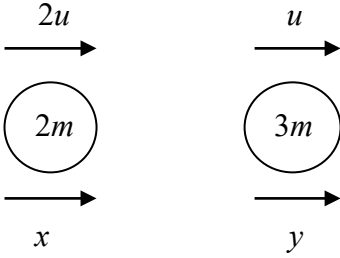
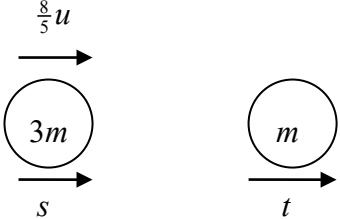
Question Number	Scheme	Marks
7.	<p>(a)</p>  <p>LM $4mu + 3mu = 2mx + 3my$ NEL $y - x = \frac{1}{2}u$ Solving to $y = \frac{8}{5}u$ *</p> <p>(b)</p> <p>$x = \frac{11}{10}u$ or equivalent Energy loss $\frac{1}{2} \times 2m \left((2u)^2 - \left(\frac{11}{10}u \right)^2 \right) + \frac{1}{2} \times 3m \left(u^2 - \left(\frac{8}{5}u \right)^2 \right)$ $= \frac{9}{20}mu^2$</p> <p>(c)</p>  <p>LM $\frac{24}{5}mu = 3ms + mt$ NEL $t - s = \frac{8}{5}eu$ Solving to $s = \frac{2}{5}u(3 - e)$</p> <p>For a further collision $\frac{11}{10}u > \frac{2}{5}u(3 - e)$ $e > \frac{1}{4}$ ignore $e \leq 1$</p>	<p>M1 A1 B1 M1 A1 (5)</p> <p>B1 M1 A(2,1,0) A1 (5)</p> <p>M1 A1 B1 M1 A1 M1 A1 (7) [17]</p>

Examiner reports

Question 1

Most candidates were confident in completing this question. There were few sign errors in setting up the equations for motion up the inclined road. The errors that were seen usually involved the omission of g , errors in resolving, or confusion over the number of zeros when converting 12 kW to 12000 W.

Many candidates lost the final mark due to giving the final answer to too many significant figures. Answers to questions involving the substitution of a value for g should be given to 2 or at most 3 significant figures. A small number of candidates tried to bring in acceleration, not realising that this would be zero due to the car moving with constant speed.

Question 2

The candidates did well in this question compared to similar questions on previous papers.

(a) This was usually well answered with most candidates confident in using the \mathbf{i} , \mathbf{j} notation in the differentiation. A very small minority of candidates chose to integrate. The differentiation was well done but there was an occasional misread of $3t^3$ as $3t^2$.

(b) The majority of candidates used the \mathbf{j} component of their velocity to find the value of t but some used the \mathbf{i} component in error. A very small number used the \mathbf{j} component of \mathbf{p} . Candidates starting with the correct equation, $9t^2 - 4 = 0$, often made errors in their attempt to solve for t ; common incorrect answers included $2/9$, $4/3$ and $3/2$. Some candidates demonstrated little understanding of what the question was asking for.

(c) Impulse was well understood but there were still some candidates confused between the initial and the final velocity. There were also some elegant solutions to provide the velocity in terms of t and going no further. Here too some candidates lost the final mark due to algebraic or sign errors.

Question 3

Few candidates had problems finding the frictional force in part (a), but once again many candidates were insecure about finding work done. Many candidates found the net work done by the horizontal force and against friction, rather than simply the work done against friction.

As usual the most popular approach in part (b) was to find the acceleration of the block and then the velocity after 50 m using $v^2 = u^2 + 2as$. A significant proportion of candidates who attempted to use the work-energy principle missed one or more terms. However, many of those candidates who misinterpreted part (a) were able to use their net work done successfully to find v using this method.

Question 4

Many candidates achieved full marks on this question, whilst others just missed out on the final mark because they did not notice the instruction to give their final answer correct to the nearest degree.

(a) Where there were difficulties these usually arose when a candidate tried to work with the geometry of the triangle, finding lengths of medians, etc in order to find the location of the centre of mass of the triangle – many seemed to be completely unaware of the simple result they could apply and invariably made algebraic errors in their work. Most candidates understood that the circle had been cut out of the triangle, but quite a few added the circle to the triangle in their working. A few candidates treated the triangle as if it were just three rods, and others confused the centre of mass of the triangle with the centre of mass of the set square in the course of their working.

(b) Most candidates correctly identified the required angle. A few did not use their answers from part (a) at all, they simply found the angle BCA .

Question 5

Part (a) A few candidates struggled to find their way into this question, sometimes attempting to start by taking moments about B, C or D rather than about A. Weaker candidates would have helped themselves by marking the unknown distance clearly on the diagram. There were however many correct solutions, with most errors due to omitting the distance from a term in the moments equation, or omitting g from the weight.

Part (b) Many candidates assumed that the resultant reaction on the hinge at A was perpendicular to the wall, or perpendicular to the beam. Candidates who attempted to use moments rather than resolving tended to be more prone to error. Those candidates who did find both components usually went on to combine them correctly to find the reaction. Inappropriate accuracy in the final answer was a common problem – 4s.f. is not appropriate having used an approximation for g .

Question 6

Q6(a) was answered well with most candidates showing sufficient working to confirm the given answer. The most common approach was to find values for $u \cos \theta$ and $u \sin \theta$, and then divide to find $\tan \theta$. A few correctly substituted from one equation into the other to find the equation of the trajectory. Some candidates made sign errors in the equation for the vertical component of the motion, yet still claimed to reach $\tan \theta = 2.2$. A small number of candidates did not read the question carefully enough to realise that the ball passed the top of the post when $t = 2$ and were unable to make progress.

In Q6(b) having been given the value for $\tan \theta$ in Q6(a), most candidates went on to find u correctly, either by using $u \cos \theta$ or $u \sin \theta$ or by using Pythagoras. Most errors were due to incorrect rounding of the final answer to give 9.66 or 9.68.

In Q6(c) those candidates who formed a correct quadratic in T usually went on to find the value of T correctly. There were a few sign errors in the equation, but more commonly candidates were confused between u and $u \sin \theta$ - it was common to see 9.67 used in place of 8.8. Despite the fact that it requires additional work, some candidates prefer to split the task into two parts, finding the time to the maximum height and the time from there to the ground.

Q6(d) proved to be the most challenging part of the question. There were some candidates who did not understand the question and used components of distance rather than velocity here. Almost all good attempts used *suvat* equations, with just a few candidates using an energy method. The use of $v^2 = u^2 + 2as$ proved slightly more successful than use of $v = u + at$, as sign errors or rounding errors were more common in the latter. Over-specified final answers were often an issue here, with several candidates offering four significant figures after using approximate values for u and T .

Question 7

This question was generally well understood and answered. Most errors were caused by poor presentation leading to carelessness. Candidates who kept all the velocities in the direction of the original velocities usually fared better than those who reversed one or more velocity. The clearest solutions included clearly annotated diagrams which made the relative directions of motion very clear. In the weaker solutions it was sometimes difficult to work out the candidate's thoughts about what happened in each collision - the question did not give them names for the speeds after the initial collision and this gave rise to problems for some candidates who often gave the same name to more than one variable. Candidates with an incorrect or inconsistent application of Newton's Experimental Law lost a lot of time trying to obtain the given answer for the speed of Q after the first collision. In part (b) although most candidates attempted to form a valid expression for the change in kinetic energy, the m and u^2 were too often discarded along the way.

In part (c), and to a lesser extent in part (a), the tendency to want to solve simultaneous equations by substitution, rather than by elimination, produced untidy and unwieldy expressions which often led to arithmetical errors; a shame when the original equations were correct. Most candidates interpreted the final part correctly, although too many wanted to substitute $11/10u$ rather than tackle an inequality - it was clear that many candidates were not confident in setting up an inequality. Some problems did occur where students assumed the reversal of the direction of motion of Q following the collision but failed to take account of this in setting up their inequality.

Statistics for M2 Practice Paper Silver 1

Qu	Max Score	Modal score	Mean %	Mean average scored by candidates achieving grade:							
				ALL	A*	A	B	C	D	E	U
1	5		88.2	4.41	4.84	4.71	4.50	4.22	3.72	3.15	1.98
2	9		80.6	7.25		8.09	6.43	6.22	4.53	4.19	2.47
3	8		79.6	6.37		7.04	5.72	5.11	5.14	3.42	1.96
4	12		74.2	8.90		9.88	7.64	5.47	3.97	2.54	0.83
5	9		71.3	6.42		7.92	6.54	5.38	4.14	3.22	1.55
6	15	15	73.0	10.91	13.18	12.33	9.40	7.60	5.51	4.28	2.00
7	17		69.6	11.83		14.50	10.59	7.86	5.86	4.87	2.18
	75		74.8	56.09		64.47	50.82	41.86	32.87	25.67	12.97