

OXFORD CAMBRIDGE AND RSA EXAMINATIONS

**Advanced Subsidiary General Certificate of Education
Advanced General Certificate of Education**

MEI STRUCTURED MATHEMATICS

4761

Mechanics 1

Tuesday **10 JANUARY 2006** Afternoon 1 hour 30 minutes

Additional materials:
8 page answer booklet
Graph paper
MEI Examination Formulae and Tables (MF2)

TIME 1 hour 30 minutes

INSTRUCTIONS TO CANDIDATES

- Write your name, centre number and candidate number in the spaces provided on the answer booklet.
- Answer **all** the questions.
- You are permitted to use a graphical calculator in this paper.
- Final answers should be given to a degree of accuracy appropriate to the context.

INFORMATION FOR CANDIDATES

- The number of marks is given in brackets [] at the end of each question or part question.
- You are advised that an answer may receive **no marks** unless you show sufficient detail of the working to indicate that a correct method is being used.
- The acceleration due to gravity is denoted by $g \text{ m s}^{-2}$. Unless otherwise instructed, when a numerical value is needed, use $g = 9.8$.
- The total number of marks for this paper is 72.

This question paper consists of 5 printed pages and 3 blank pages.

2

Section A (36 marks)

- 1 A particle travels in a straight line during the time interval $0 \leq t \leq 12$, where t is the time in seconds. Fig. 1 is the velocity-time graph for the motion.

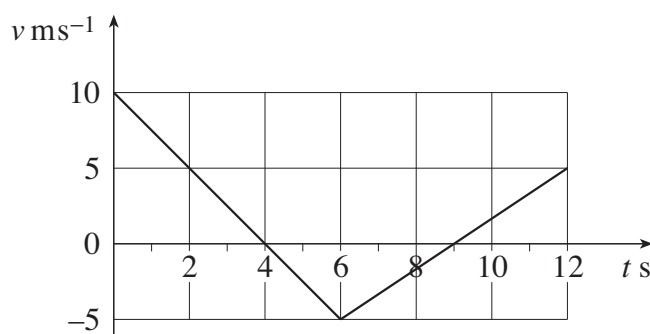

Fig. 1

- (i) Calculate the acceleration of the particle in the interval $0 < t < 6$. [2]
- (ii) Calculate the distance travelled by the particle from $t = 0$ to $t = 4$. [2]
- (iii) When $t = 0$ the particle is at A. Calculate how close the particle gets to A during the interval $4 \leq t \leq 12$. [2]
- 2 Fig. 2 shows a light string with an object of mass 4 kg attached at end A. The string passes over a smooth pulley and its other end B is attached to two light strings BC and BD of the same length. The strings BC and BD are attached to horizontal ground and are each inclined at 20° to the vertical.

The system is in equilibrium.

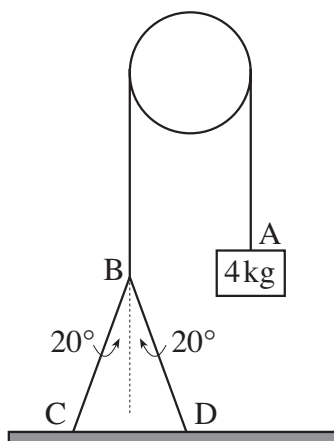

Fig. 2

- (i) What information in the question tells you that the tension is the same throughout the string AB? [1]
- (ii) What is the tension in the string AB? [1]
- (iii) Calculate the tension in the strings BC and BD. [3]

3

3 A force \mathbf{F} is given by $\mathbf{F} = (3.5\mathbf{i} + 12\mathbf{j})$ N, where \mathbf{i} and \mathbf{j} are horizontal unit vectors east and north respectively.

(i) Calculate the magnitude of \mathbf{F} and also its direction as a bearing. [3]

(ii) \mathbf{G} is the force $(7\mathbf{i} + 24\mathbf{j})$ N. Show that \mathbf{G} and \mathbf{F} are in the same direction and compare their magnitudes. [2]

(iii) Force \mathbf{F}_1 is $(9\mathbf{i} - 18\mathbf{j})$ N and force \mathbf{F}_2 is $(12\mathbf{i} + q\mathbf{j})$ N. Find q so that the sum $\mathbf{F}_1 + \mathbf{F}_2$ is in the direction of \mathbf{F} . [2]

4 A car and its trailer travel along a straight, horizontal road. The coupling between them is light and horizontal. The car has mass 900 kg and resistance to motion 100 N, the trailer has mass 700 kg and resistance to motion 300 N, as shown in Fig. 4. The car and trailer have an acceleration of 1.5 m s^{-2} .

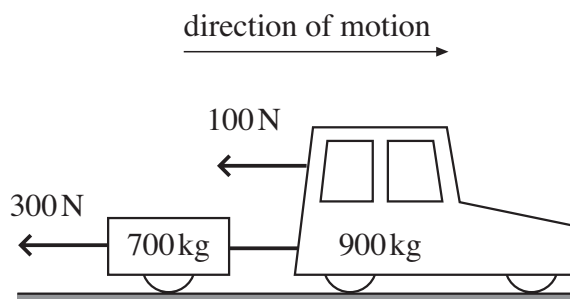

Fig. 4

(i) Calculate the driving force of the car. [3]

(ii) Calculate the force in the coupling. [2]

5 The acceleration of a particle of mass 4 kg is given by $\mathbf{a} = (9\mathbf{i} - 4t\mathbf{j}) \text{ m s}^{-2}$, where \mathbf{i} and \mathbf{j} are unit vectors and t is the time in seconds.

(i) Find the acceleration of the particle when $t = 0$ and also when $t = 3$. [1]

(ii) Calculate the force acting on the particle when $t = 3$. [1]

The particle has velocity $(4\mathbf{i} + 2\mathbf{j}) \text{ m s}^{-1}$ when $t = 1$.

(iii) Find an expression for the velocity of the particle at time t . [4]

4

- 6 A car is driven with constant acceleration, $a \text{ m s}^{-2}$, along a straight road. Its speed when it passes a road sign is $u \text{ m s}^{-1}$. The car travels 14 m in the 2 seconds after passing the sign; 5 seconds after passing the sign it has a speed of 19 m s^{-1} .

(i) Write down two equations connecting a and u . Hence find the values of a and u . [5]

(ii) What distance does the car travel in the 5 seconds after passing the road sign? [2]

Section B (36 marks)

- 7 Clive and Ken are trying to move a box of mass 50 kg on a rough, horizontal floor. As shown in Fig. 7, Clive always pushes horizontally and Ken always pulls at an angle of 30° to the horizontal. Each of them applies forces to the box in the same vertical plane as described below.

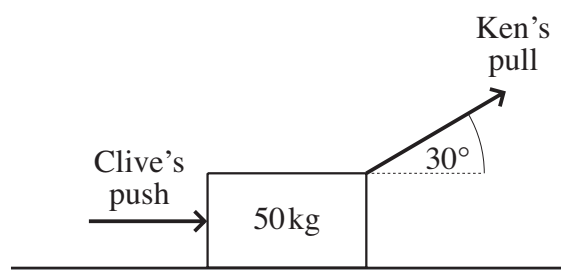

Fig. 7

Initially, the box is in equilibrium with Clive pushing with a force of 60 N and Ken not pulling at all.

(i) What is the resistance to motion of the box? [1]

Ken now adds a pull of 70 N to Clive's push of 60 N. The box remains in equilibrium.

(ii) What now is the resistance to motion of the box? [2]

(iii) Calculate the normal reaction of the floor on the box. [3]

The frictional resistance to sliding of the box is 125 N.

Clive now pushes with a force of 160 N but Ken does not pull at all.

(iv) Calculate the acceleration of the box. [2]

Clive stops pushing when the box has a speed of 1.5 m s^{-1} .

(v) How far does the box then slide before coming to rest? [4]

Ken and Clive now try again. Ken pulls with a force of $Q \text{ N}$ and Clive pushes with a force of 160 N. The frictional resistance to sliding of the box is now 115 N and the acceleration of the box is 3 m s^{-2} .

(vi) Calculate the value of Q . [4]

5

- 8 A girl throws a small stone with initial speed 14 m s^{-1} at an angle of 60° to the horizontal from a point 1 m above the ground. She throws the stone directly towards a vertical wall of height 6 m standing on horizontal ground. The point O is on the ground directly below the point of projection, as shown in Fig. 8. Air resistance is negligible.

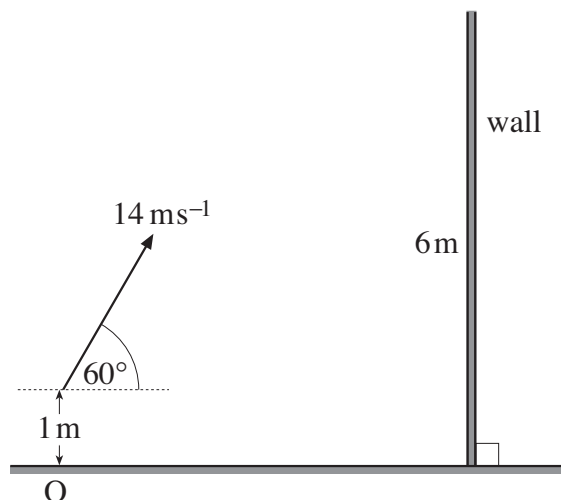

Fig. 8

- (i) Write down an expression in terms of t for the horizontal displacement of the stone from O , t seconds after projection. Find also an expression for the height of the stone above O at this time. [5]

The stone is at the top of its trajectory when it passes over the wall.

- (ii) (A) Find the time it takes for the stone to reach its highest point. [2]
 (B) Calculate the distance of O from the base of the wall. [2]
 (C) Show that the stone passes over the wall with 2.5 m clearance. [4]
- (iii) Find the cartesian equation of the trajectory of the stone referred to the horizontal and vertical axes, Ox and Oy . There is no need to simplify your answer. [2]

The girl now moves away a further distance $d \text{ m}$ from the wall. She throws a stone as before and it just passes over the wall.

- (iv) Calculate d . [5]