

Paper Reference(s)

**6689/01**

# **Edexcel GCE**

## **Decision Mathematics D1**

### **Advanced/Advanced Subsidiary**

Tuesday 5 June 2007 – Afternoon

Time: 1 hour 30 minutes

**Materials required for examination**

Nil

**Items included with question papers**

D1 Answer book

**Candidates may use any calculator allowed by the regulations of the Joint Council for Qualifications. Calculators must not have the facility for symbolic algebra manipulation, differentiation and integration, or have retrievable mathematical formulas stored in them.**

#### **Instructions to Candidates**

---

Write your answers for this paper in the D1 answer book provided.

In the boxes on the answer book, write your centre number, candidate number, your surname, initial(s) and signature.

When a calculator is used, the answer should be given to an appropriate degree of accuracy.

Complete your answers in blue or black ink or pencil.

Do not return the question paper with the answer book.

#### **Information for Candidates**

---

Full marks may be obtained for answers to ALL questions.

The marks for individual questions and the parts of questions are shown in round brackets: e.g. (2).

There are 8 questions in this question paper. The total mark for this paper is 75.

There are 12 pages in this question paper. The answer book has 16 pages. Any blank pages are indicated.

#### **Advice to Candidates**

---

You must ensure that your answers to parts of questions are clearly labelled.

You should show sufficient working to make your methods clear to the Examiner.

Answers without working may not gain full credit.

Printer's Log. No.

**N26122A**



N 2 6 1 2 2 A

W850/R6689/57570 3/3/3/

This publication may be reproduced only in accordance with Edexcel Limited copyright policy. ©2007 Edexcel Limited.

*Turn over*

**edexcel**   
advancing learning, changing lives

**Write your answers in the D1 answer book for this paper.**

1. Explain what is meant by a planar graph.

**(Total 2 marks)**

---

2.

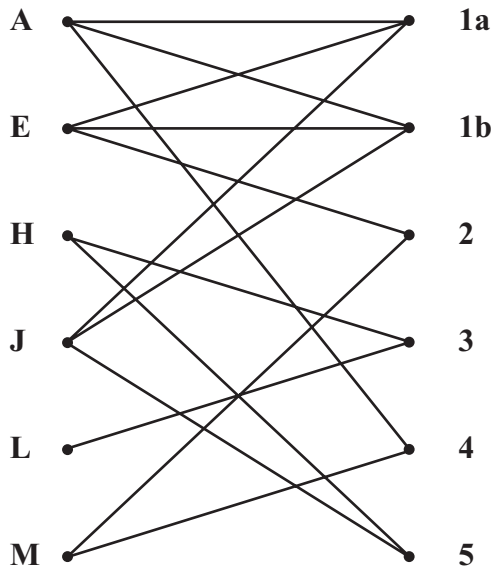

**Figure 1**

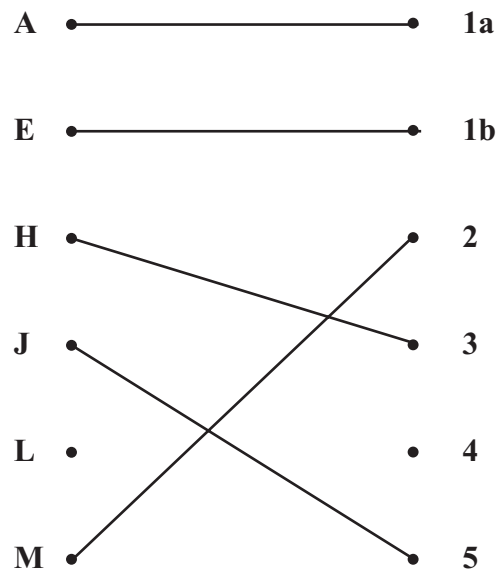

**Figure 2**

Six workers, Annie, Emma, Hannah, Jerry, Louis and Morand, are to be assigned to five tasks, 1,2,3,4 and 5.

For safety reasons, task 1 must be done by two people working together.

A bipartite graph showing the possible allocations of the workers is given in Figure 1 and an initial matching is given in Figure 2.

The maximum matching algorithm will be used to obtain a complete matching.

(a) Although there are five tasks, six vertices have been created on the right hand side of each bipartite graph. Explain why this is necessary when applying this algorithm. **(2)**

(b) Find an alternating path and the complete matching it gives. **(3)**

Hannah is now unable to do task 5 due to health reasons.

(c) Explain why a complete matching is no longer possible. **(2)**

**(Total 7 marks)**

---

3.

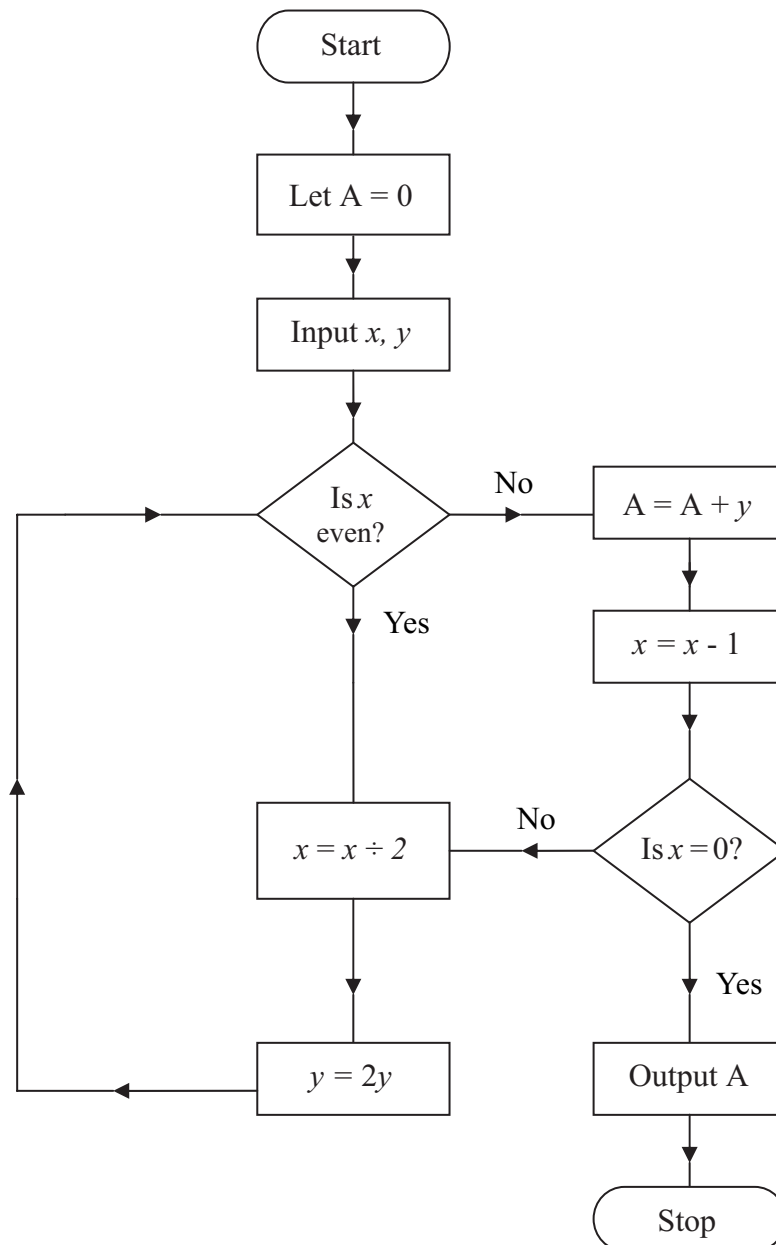

**Figure 3**

An algorithm is described by the flow chart shown in Figure 3.

(a) Given that  $x = 54$  and  $y = 63$ , complete the table in the answer book to show the results obtained at each step when the algorithm is applied. (7)

(b) State what the algorithm achieves. (2)

**(Total 9 marks)**

4.

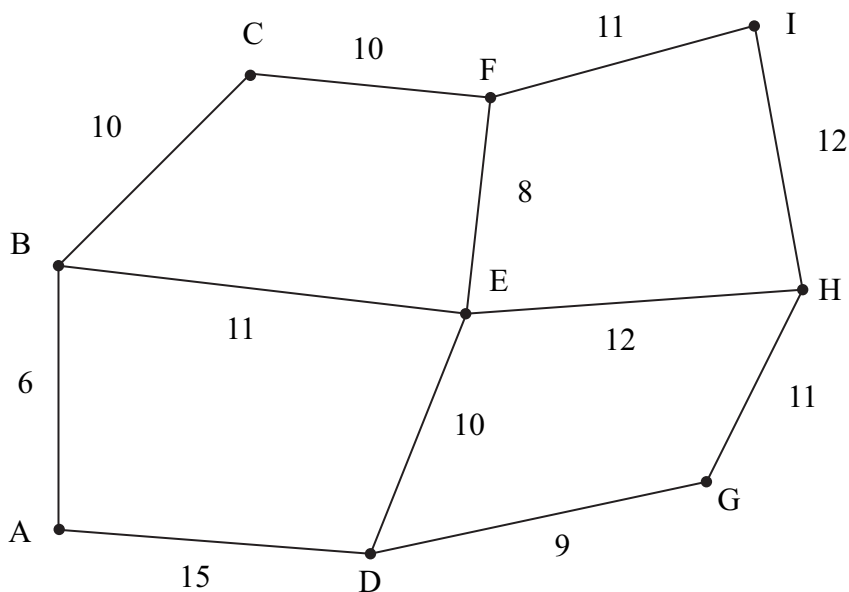

**Figure 4**

Figure 4 models a network of underground tunnels that have to be inspected. The number on each arc represents the length, in km, of each tunnel.

Joe must travel along each tunnel at least once and the length of his inspection route must be minimised.

The total weight of the network is 125 km.

The inspection route must start and finish at A.

- (a) Use an appropriate algorithm to find the length of the shortest inspection route. You should make your method and working clear. (5)

Given that it is now permitted to start and finish the inspection at two distinct vertices,

- (b) state which two vertices should be chosen to minimise the length of the new route. Give a reason for your answer. (2)

**(Total 7 marks)**

---

5.

	<i>M</i>	<i>A</i>	<i>B</i>	<i>C</i>	<i>D</i>	<i>E</i>
<i>M</i>	-	215	170	290	210	305
<i>A</i>	215	-	275	100	217	214
<i>B</i>	170	275	-	267	230	200
<i>C</i>	290	100	267	-	180	220
<i>D</i>	210	217	230	180	-	245
<i>E</i>	305	214	200	220	245	-

The table shows the cost, in pounds, of linking five automatic alarm sensors, *A, B, C, D* and *E*, and the main reception, *M*.

- (a) Use Prim's algorithm, starting from *M*, to find a minimum spanning tree for this table of costs. You must list the **arcs** that form your tree **in the order that they are selected**. (3)
- (b) Draw your tree using the vertices given in Diagram 1 in the answer book. (1)
- (c) Find the total weight of your tree. (1)
- (d) Explain why it is not necessary to check for cycles when using Prim's algorithm. (2)

---

(Total 7 marks)

6.

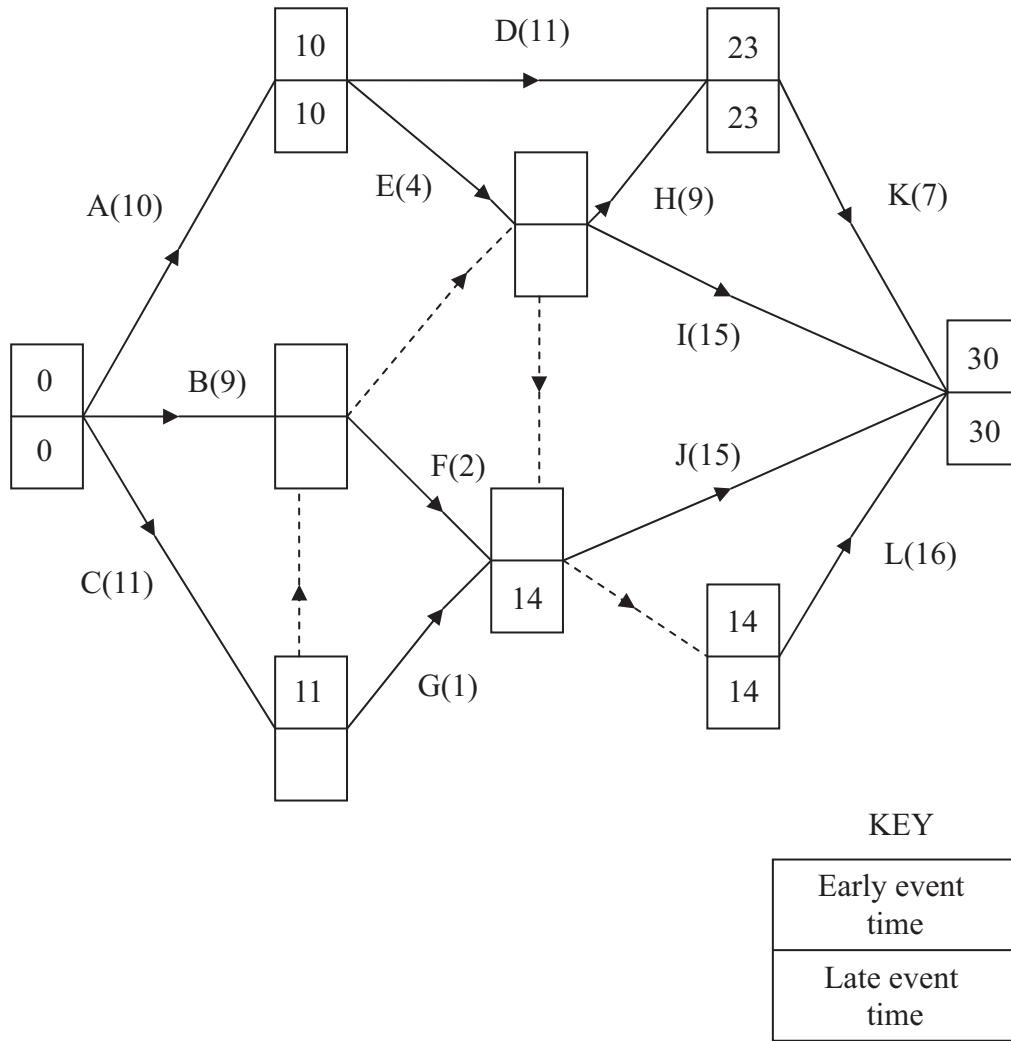

**Figure 5**

The network in Figure 5 shows the activities that need to be undertaken to complete a project. Each activity is represented by an arc. The number in brackets is the duration of the activity in days. The early and late event times are to be shown at each vertex and some have been completed for you.

- (a) Calculate the missing early and late times and hence complete Diagram 2 in your answer book. (3)
- (b) List the two critical paths for this network. (2)
- (c) Explain what is meant by a critical path. (2)

The sum of all the activity times is 110 days and each activity requires just one worker. The project must be completed in the minimum time.

- (d) Calculate a lower bound for the number of workers needed to complete the project in the minimum time. You must show your working. (2)
- (e) List the activities that must be happening on day 20. (2)
- (f) Comment on your answer to part (e) with regard to the lower bound you found in part (d). (1)
- (g) Schedule the activities, using the minimum number of workers, so that the project is completed in 30 days. (3)

**(Total 15 marks)**

---

7. The tableau below is the initial tableau for a linear programming problem in  $x$ ,  $y$  and  $z$ . The objective is to maximise the profit,  $P$ .

basic variable	$x$	$y$	$z$	$r$	$s$	$t$	Value
$r$	12	4	5	1	0	0	246
$s$	9	6	3	0	1	0	153
$t$	5	2	-2	0	0	1	171
$P$	-2	-4	-3	0	0	0	0

Using the information in the tableau, write down

- (a) the objective function, (2)

- (b) the three constraints as inequalities with integer coefficients. (3)

Taking the most negative number in the profit row to indicate the pivot column at each stage,

- (c) solve this linear programming problem. Make your method clear by stating the row operations you use. (9)

- (d) State the final values of the objective function and each variable. (3)

One of the constraints is not at capacity.

- (e) Explain how it can be identified. (1)

**(Total 18 marks)**

---



8.

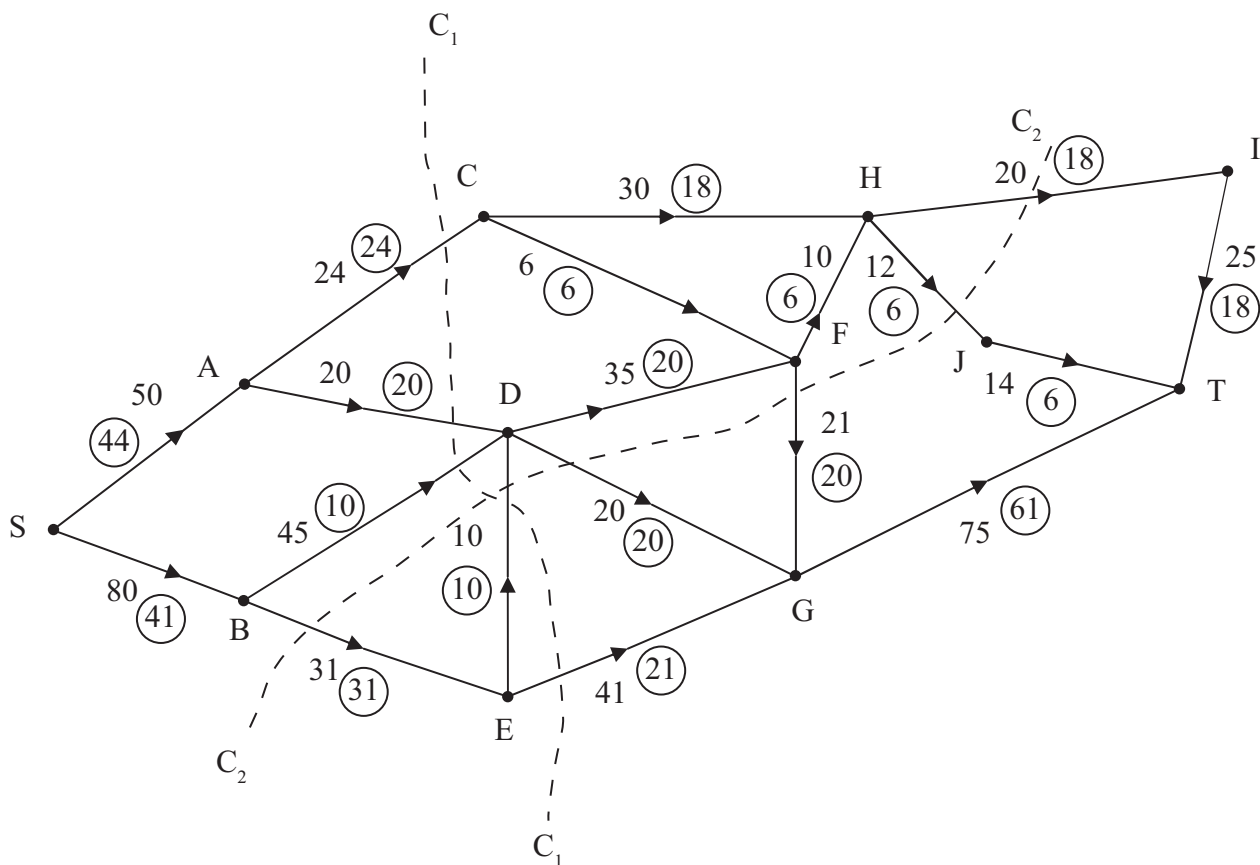

Figure 6

Figure 6 shows a capacitated, directed network. The number on each arc represents the capacity of that arc. The numbers in circles represent an initial flow.

- (a) State the value of the initial flow. (1)
- (b) State the capacities of cuts  $C_1$  and  $C_2$ . (2)

Diagram 3 in the answer book shows the labelling procedure applied to the above network.

- (c) Using Diagram 3, increase the flow by a further 19 units. You **must** list each flow-augmenting path you use, together with its flow. (5)
- (d) Prove that the flow is now maximal. (2)

(Total 10 marks)

TOTAL FOR PAPER: 75 MARKS

END