

Possible C2 questions from past papers P1—P3

Source of the original question is given in brackets, e.g. [P1 January 2001 Question 1]; a question which has been edited is indicated with an asterisk, e.g. [P1 January 2001 Question 8*].

1. Find all values of θ in the interval $0 \leq \theta < 360$ for which

(a) $\cos(\theta + 75)^\circ = 0$. (3)

(b) $\sin 2\theta^\circ = 0.7$, giving your answers to one decimal place. (5)

[P1 January 2001 Question 3]

2.

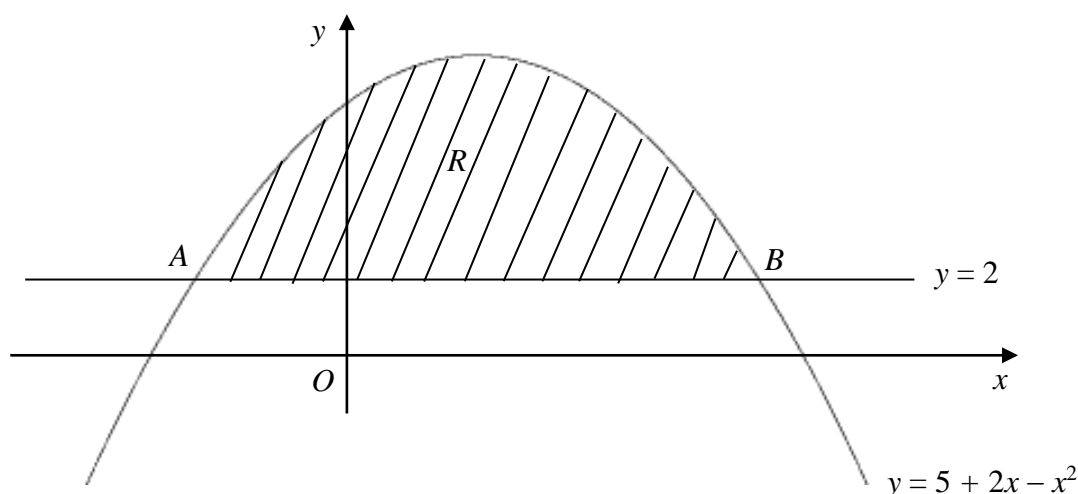

Fig. 1

Figure 1 shows the curve with equation $y = 5 + 2x - x^2$ and the line with equation $y = 2$. The curve and the line intersect at the points A and B .

(a) Find the x -coordinates of A and B . (3)

The shaded region R is bounded by the curve and the line.

(b) Find the area of R . (6)

[P1 January 2001 Question 4]

3. The third and fourth terms of a geometric series are 6.4 and 5.12 respectively.

Find

(a) the common ratio of the series, (2)

(b) the first term of the series, (2)

(c) the sum to infinity of the series. (2)

(d) Calculate the difference between the sum to infinity of the series and the sum of the first 25 terms of the series. (4)

[P1 January 2001 Question 5]

4.

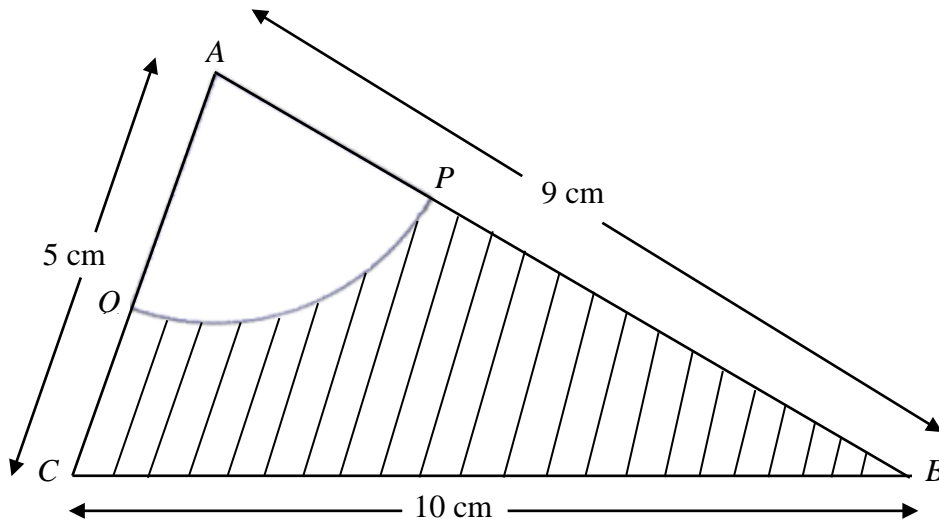

Fig. 3

Triangle ABC has $AB = 9$ cm, $BC = 10$ cm and $CA = 5$ cm.

A circle, centre A and radius 3 cm, intersects AB and AC at P and Q respectively, as shown in Fig. 3.

(a) Show that, to 3 decimal places, $\angle BAC = 1.504$ radians. (3)

Calculate,

(b) the area, in cm^2 , of the sector APQ , (2)

(c) the area, in cm^2 , of the shaded region $BPQC$, (3)

(d) the perimeter, in cm, of the shaded region $BPQC$. (4)

[P1 January 2001 Question 7]

5.

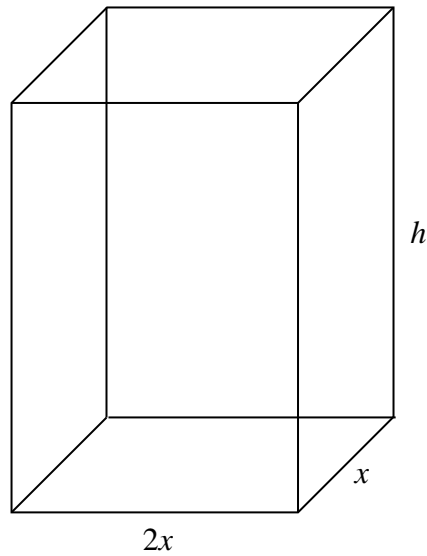

Fig. 4

A manufacturer produces cartons for fruit juice. Each carton is in the shape of a closed cuboid with base dimensions $2x$ cm by x cm and height h cm, as shown in Fig. 4.

Given that the capacity of a carton has to be 1030 cm^3 ,

(a) express h in terms of x , (2)

(b) show that the surface area, $A \text{ cm}^2$, of a carton is given by

$$A = 4x^2 + \frac{3090}{x}. \quad (3)$$

The manufacturer needs to minimise the surface area of a carton.

(c) Use calculus to find the value of x for which A is a minimum. (5)

(d) Calculate the minimum value of A . (2)

(e) Prove that this value of A is a minimum. (2)

[P1 January 2001 Question 8]

6. Given that $2 \sin 2\theta = \cos 2\theta$,

(a) show that $\tan 2\theta = 0.5$. **(1)**

(b) Hence find the values of θ , to one decimal place, in the interval $0 \leq \theta < 360$ for which $2 \sin 2\theta^\circ = \cos 2\theta^\circ$. **(5)**

[P1 June 2001 Question 2]

7.

Figure 1

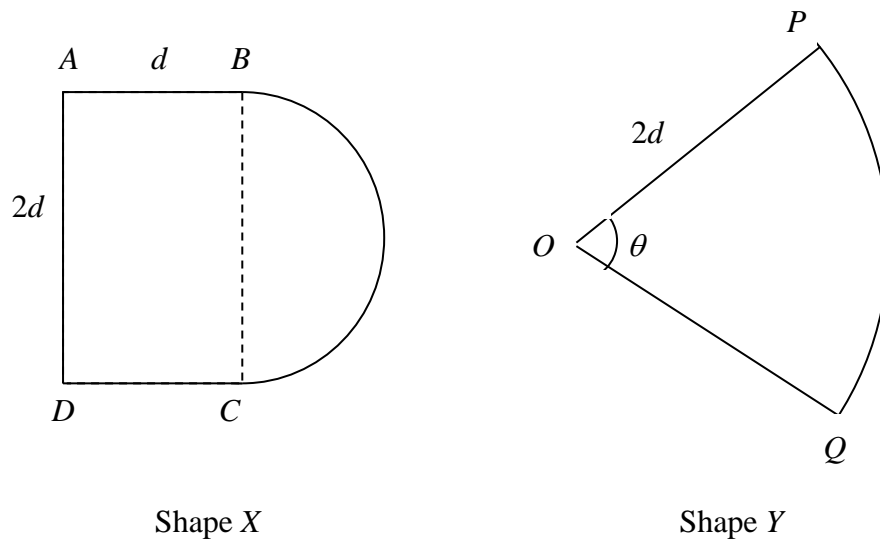

Figure 1 shows the cross-sections of two drawer handles.

Shape X is a rectangle $ABCD$ joined to a semicircle with BC as diameter. The length $AB = d$ cm and $BC = 2d$ cm.

Shape Y is a sector OPQ of a circle with centre O and radius $2d$ cm. Angle POQ is θ radians.

Given that the areas of the shapes X and Y are equal,

(a) prove that $\theta = 1 + \frac{1}{4}\pi$. (5)

Using this value of θ , and given that $d = 3$, find in terms of π ,

(b) the perimeter of shape X , (2)

(c) the perimeter of shape Y . (3)

(d) Hence find the difference, in mm, between the perimeters of shapes X and Y . (2)

[P1 June 2001 Question 6]

8.

Figure 2

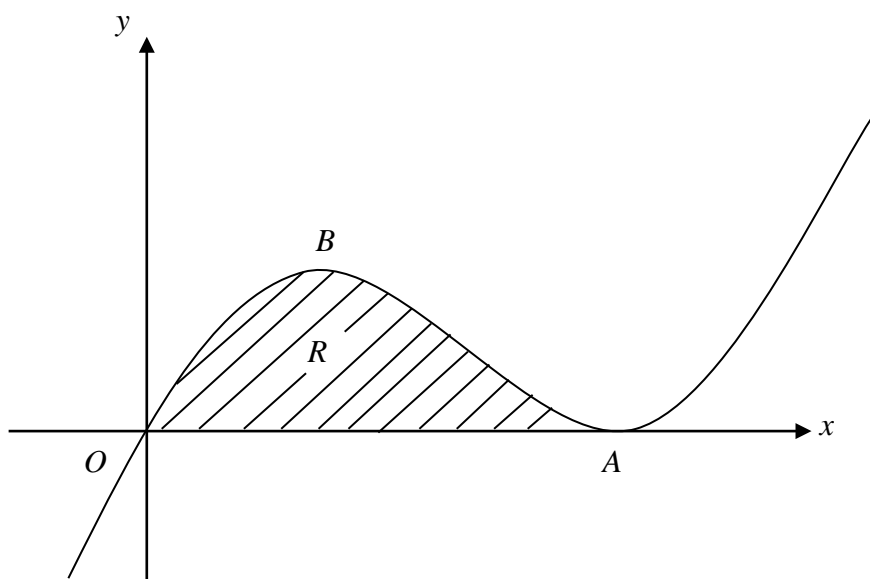

Figure 2 shows part of the curve with equation

$$y = x^3 - 6x^2 + 9x.$$

The curve touches the x -axis at A and has a maximum turning point at B .

(a) Show that the equation of the curve may be written as

$$y = x(x - 3)^2,$$

and hence write down the coordinates of A .

(2)

(b) Find the coordinates of B .

(5)

The shaded region R is bounded by the curve and the x -axis.

(c) Find the area of R .

(5)

[P1 June 2001 Question 7]

9. A population of deer is introduced into a park. The population P at t years after the deer have been introduced is modelled by

$$P = \frac{2000a^t}{4 + a^t},$$

where a is a constant. Given that there are 800 deer in the park after 6 years,

- (a) calculate, to 4 decimal places, the value of a , (4)
- (b) use the model to predict the number of years needed for the population of deer to increase from 800 to 1800. (4)
- (c) With reference to this model, give a reason why the population of deer cannot exceed 2000. (1)

[P2 June 2001 Question 6]

10. (a) Given that

$$(2 + x)^5 + (2 - x)^5 = A + Bx^2 + Cx^4,$$

find the values of the constants A , B and C .

(6)

- (b) Using the substitution $y = x^2$ and your answers to part (a), solve,

$$(2 + x)^5 + (2 - x)^5 = 349.$$

(5)

[P2 June 2001 Question 8]

11. A circle C has equation

$$x^2 + y^2 - 10x + 6y - 15 = 0.$$

- (a) Find the coordinates of the centre of C . (2)
- (b) Find the radius of C . (2)

[P3 June 2001 Question 1]

12. $f(x) \equiv ax^3 + bx^2 - 7x + 14$, where a and b are constants.

Given that when $f(x)$ is divided by $(x - 1)$ the remainder is 9,

(a) write down an equation connecting a and b . (2)

Given also that $(x + 2)$ is a factor of $f(x)$,

(b) find the values of a and b . (4)

[P3 June 2001 Question 2]

13. $f(x) = x^3 - x^2 - 7x + c$, where c is a constant.

Given that $f(4) = 0$,

(a) find the value of c , (2)

(b) factorise $f(x)$ as the product of a linear factor and a quadratic factor. (3)

(c) Hence show that, apart from $x = 4$, there are no real values of x for which $f(x) = 0$. (2)

[P1 January 2002 Question 2]

14. Find the values of θ , to 1 decimal place, in the interval $-180 \leq \theta < 180$ for which

$$2 \sin^2 \theta^\circ - 2 \sin \theta^\circ = \cos^2 \theta^\circ. \quad (8)$$

[P1 January 2002 Question 3]

15.

Figure 1

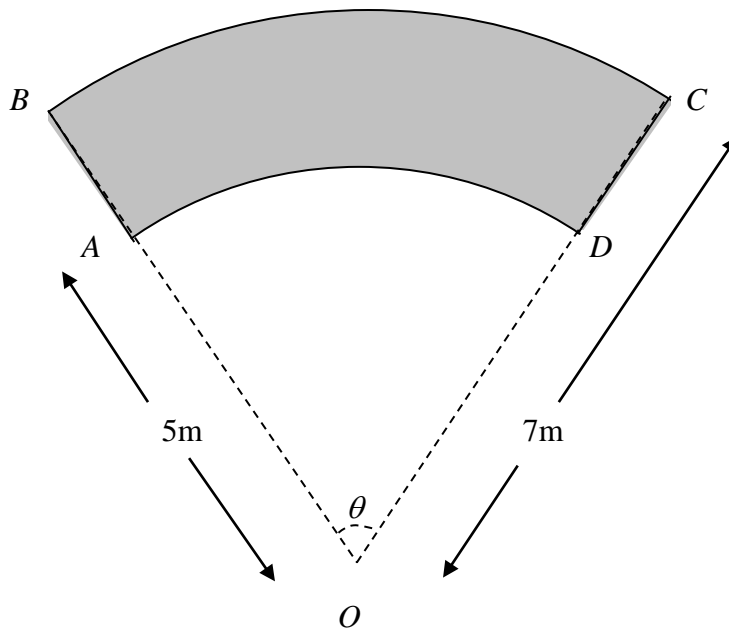

Figure 1 shows a gardener's design for the shape of a flower bed with perimeter $ABCD$.

AD is an arc of a circle with centre O and radius 5 m.

BC is an arc of a circle with centre O and radius 7 m.

OAB and ODC are straight lines and the size of $\angle AOD$ is θ radians.

(a) Find, in terms of θ , an expression for the area of the flower bed.

(3)

Given that the area of the flower bed is 15 m^2 ,

(b) show that $\theta = 1.25$,

(2)

(c) calculate, in m, the perimeter of the flower bed.

(3)

The gardener now decides to replace arc AD with the straight line AD .

(d) Find, to the nearest cm, the reduction in the perimeter of the flower bed.

(2)

[P1 January 2002 Question 6]

16. A geometric series is $a + ar + ar^2 + \dots$

(a) Prove that the sum of the first n terms of this series is given by

$$S_n = \frac{a(1-r^n)}{1-r}. \quad (4)$$

The second and fourth terms of the series are 3 and 1.08 respectively.

Given that all terms in the series are positive, find

(b) the value of r and the value of a , (5)

(c) the sum to infinity of the series. (3)

[P1 January 2002 Question 7]

17.

Figure 2

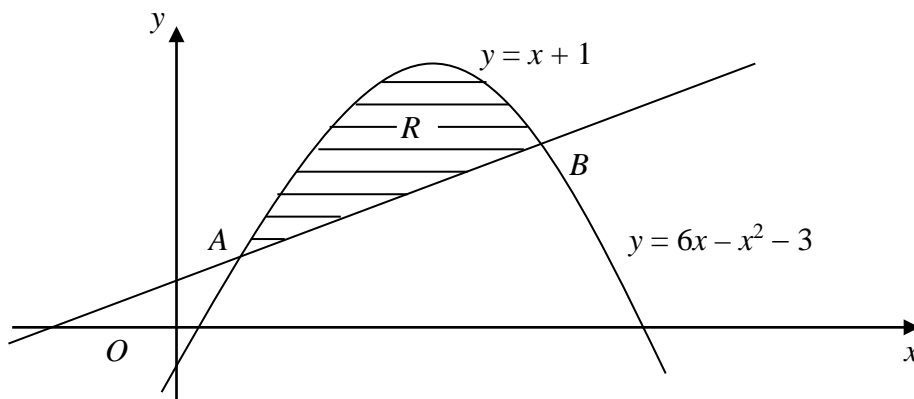

Figure 2 shows the line with equation $y = x + 1$ and the curve with equation $y = 6x - x^2 - 3$.

The line and the curve intersect at the points A and B , and O is the origin.

(a) Calculate the coordinates of A and the coordinates of B . (5)

The shaded region R is bounded by the line and the curve.

(b) Calculate the area of R . (7)

[P1 January 2002 Question 8]

18. Given that $p = \log_q 16$, express in terms of p ,

(a) $\log_q 2$, (2)

(b) $\log_q (8q)$. (4)

[P2 January 2002 Question 2]

19.
$$f(x) = \left(1 + \frac{x}{k}\right)^n, \quad k, n \in \mathbb{N}, \quad n > 2.$$

Given that the coefficient of x^3 is twice the coefficient of x^2 in the binomial expansion of $f(x)$,

(a) prove that $n = 6k + 2$. (3)

Given also that the coefficients of x^4 and x^5 are equal and non-zero,

(b) form another equation in n and k and hence show that $k = 2$ and $n = 14$. (4)

Using these values of k and n ,

(c) expand $f(x)$ in ascending powers of x , up to and including the term in x^5 . Give each coefficient as an exact fraction in its lowest terms (4)

[P2 January 2002 Question 9]

20.

$$f(x) = 4x^3 + 3x^2 - 2x - 6.$$

Find the remainder when $f(x)$ is divided by $(2x + 1)$. (3)

[P3 January 2002 Question 1]

21. A circle C has centre $(3, 4)$ and radius $3\sqrt{2}$. A straight line l has equation $y = x + 3$.
- (a) Write down an equation of the circle C . (2)
- (b) Calculate the exact coordinates of the two points where the line l intersects C , giving your answers in surds. (5)
- (c) Find the distance between these two points. (2)

[P3 January 2002 Question 4]

22.

Figure 1

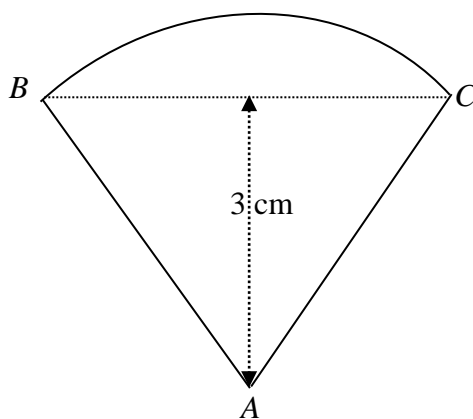

The shape of a badge is a sector ABC of a circle with centre A and radius AB , as shown in Fig 1. The triangle ABC is equilateral and has a perpendicular height 3 cm.

- (a) Find, in surd form, the length AB . (2)
- (b) Find, in terms of π , the area of the badge. (2)
- (c) Prove that the perimeter of the badge is $\frac{2\sqrt{3}}{3}(\pi + 6)$ cm. (3)

[P1 June 2002 Question 2]

23. Given that $f(x) = 15 - 7x - 2x^2$,
- (a) find the coordinates of all points at which the graph of $y = f(x)$ crosses the coordinate axes. (3)
- (b) Sketch the graph of $y = f(x)$. (2)
- (c) Calculate the coordinates of the stationary point of $f(x)$. (3)

[P1 June 2002 Question 3]

24. $f(x) = 5 \sin 3x^\circ$, $0 \leq x \leq 180$.
- (a) Sketch the graph of $f(x)$, indicating the value of x at each point where the graph intersects the x -axis. (3)
- (b) Write down the coordinates of all the maximum and minimum points of $f(x)$. (3)
- (c) Calculate the values of x for which $f(x) = 2.5$ (4)

[P1 June 2002 Question 5]

25. Given that $f(x) = (2x^{\frac{3}{2}} - 3x^{-\frac{3}{2}})^2 + 5$, $x > 0$,
- (a) find, to 3 significant figures, the value of x for which $f(x) = 5$. (3)
- (b) Show that $f(x)$ may be written in the form $Ax^3 + \frac{B}{x^3} + C$, where A , B and C are constants to be found. (3)
- (c) Hence evaluate $\int_1^2 f(x) \, dx$. (5)

[P1 June 2002 Question 6]

26.

Figure 2

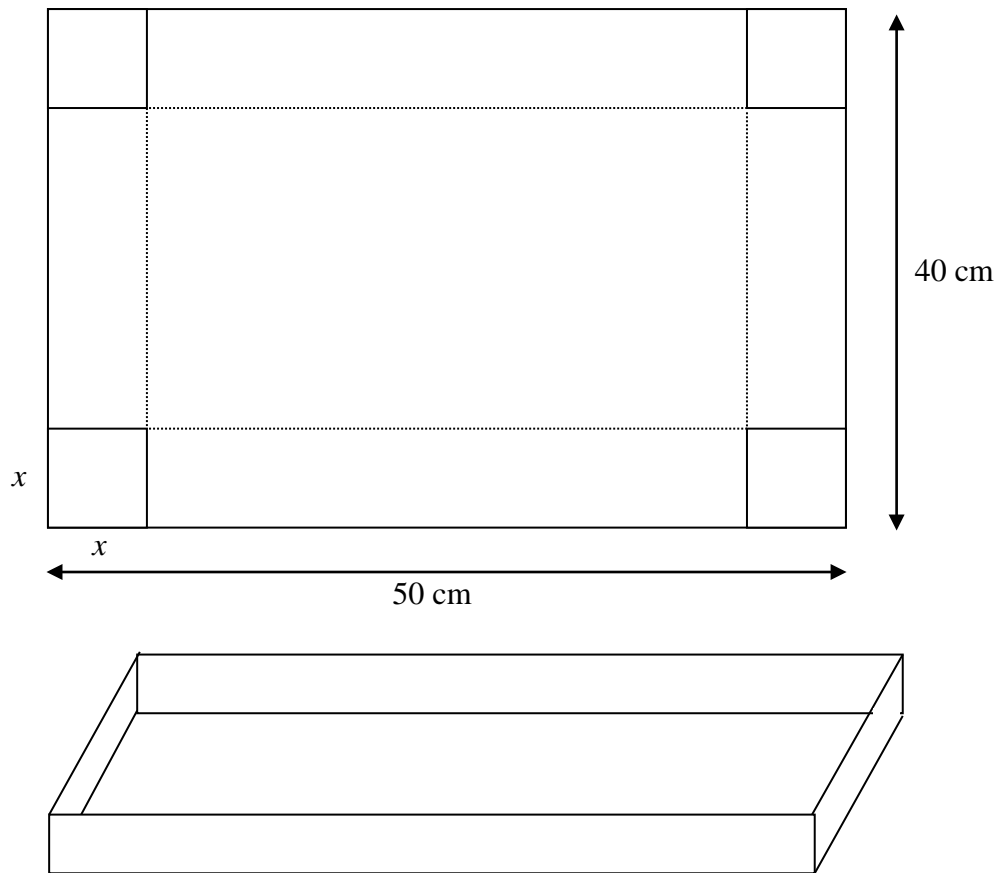

A rectangular sheet of metal measures 50 cm by 40 cm. Squares of side x cm are cut from each corner of the sheet and the remainder is folded along the dotted lines to make an open tray, as shown in Fig. 2.

(a) Show that the volume, V cm³, of the tray is given by

$$V = 4x(x^2 - 45x + 500). \quad (3)$$

(b) State the range of possible values of x . (1)

(c) Find the value of x for which V is a maximum. (4)

(d) Hence find the maximum value of V . (2)

(e) Justify that the value of V you found in part (d) is a maximum. (2)

[P1 June 2002 Question 7]

27. (a) Write down the first four terms of the binomial expansion, in ascending powers of x , of $(1 + 3x)^n$, where $n > 2$. (2)

Given that the coefficient of x^3 in this expansion is ten times the coefficient of x^2 ,

- (b) find the value of n , (2)
- (c) find the coefficient of x^4 in the expansion. (2)

[P2 June 2002 Question 1]

28. (a) Given that $3 + 2 \log_2 x = \log_2 y$, show that $y = 8x^2$. (3)

(b) Hence, or otherwise, find the roots α and β , where $\alpha < \beta$, of the equation

$$3 + 2 \log_2 x = \log_2 (14x - 3). \quad (3)$$

(c) Show that $\log_2 \alpha = -2$. (1)

(d) Calculate $\log_2 \beta$, giving your answer to 3 significant figures. (3)

[P2 June 2002 Question 5]

29. $f(x) = x^3 + ax^2 + bx - 10$, where a and b are constants.

When $f(x)$ is divided by $(x - 3)$, the remainder is 14.

When $f(x)$ is divided by $(x + 1)$, the remainder is -18 .

(a) Find the value of a and the value of b . (5)

(b) Show that $(x - 2)$ is a factor of $f(x)$. (2)

[P3 June 2002 Question 1]

30. (a) Using the factor theorem, show that $(x + 3)$ is a factor of

$$x^3 - 3x^2 - 10x + 24.$$

(2)

- (b) Factorise $x^3 - 3x^2 - 10x + 24$ completely.

(4)

[P1 November 2002 Question 2]

31. (i) Differentiate with respect to x

$$2x^3 + \sqrt{x} + \frac{x^2 + 2x}{x^2}.$$

(5)

- (ii) Evaluate

$$\int_1^4 \left(\frac{x}{2} + \frac{1}{x^2} \right) dx.$$

(5)

[P1 November 2002 Question 3]

32. (a) An arithmetic series has first term a and common difference d . Prove that the sum of the first n terms of the series is

$$\frac{1}{2}n[2a + (n - 1)d]. \quad (4)$$

A company made a profit of £54 000 in the year 2001. A model for future performance assumes that yearly profits will increase in an arithmetic sequence with common difference £ d . This model predicts total profits of £619 200 for the 9 years 2001 to 2009 inclusive.

- (b) Find the value of d . (4)

Using your value of d ,

- (c) find the predicted profit for the year 2011. (2)

An alternative model assumes that the company's yearly profits will increase in a geometric sequence with common ratio 1.06. Using this alternative model and again taking the profit in 2001 to be £54 000,

- (d) find the predicted profit for the year 2011. (3)

[P1 November 2002 Question 4]

33. (i) Solve, for $0^\circ < x < 180^\circ$, the equation

$$\sin(2x + 50^\circ) = 0.6,$$

giving your answers to 1 decimal place. (7)

- (ii) In the triangle ABC , $AC = 18$ cm, $\angle ABC = 60^\circ$ and $\sin A = \frac{1}{3}$.

(a) Use the sine rule to show that $BC = 4\sqrt{3}$. (4)

(b) Find the exact value of $\cos A$. (2)

[P1 November 2002 Question 5]

34. (a) Using the substitution $u = 2^x$, show that the equation $4^x - 2^{(x+1)} - 15 = 0$ can be written in the form $u^2 - 2u - 15 = 0$. (2)

- (b) Hence solve the equation $4^x - 2^{(x+1)} - 15 = 0$, giving your answers to 2 decimal places. (4)

[P2 November 2002 Question 2]

35. The sequence $u_1, u_2, u_3, \dots, u_n$ is defined by the recurrence relation

$$u_{n+1} = pu_n + 5, u_1 = 2, \text{ where } p \text{ is a constant.}$$

Given that $u_3 = 8$,

- (a) show that one possible value of p is $\frac{1}{2}$ and find the other value of p . (5)

Using $p = \frac{1}{2}$,

- (b) write down the value of $\log_2 p$. (1)

Given also that $\log_2 q = t$,

- (c) express $\log_2 \left(\frac{p^3}{\sqrt{q}} \right)$ in terms of t . (3)

[P2 November 2002 Question 4]

36. (a) Sketch, for $0 \leq x \leq 360^\circ$, the graph of $y = \sin(x + 30^\circ)$. (2)
- (b) Write down the coordinates of the points at which the graph meets the axes. (3)
- (c) Solve, for $0 \leq x < 360^\circ$, the equation
- $$\sin(x + 30^\circ) = -\frac{1}{2}.$$
- (3)

[P1 January 2003 Question 2]

37. A geometric series has first term 1200. Its sum to infinity is 960.
- (a) Show that the common ratio of the series is $-\frac{1}{4}$. (3)
- (b) Find, to 3 decimal places, the difference between the ninth and tenth terms of the series. (3)
- (c) Write down an expression for the sum of the first n terms of the series. (2)

Given that n is odd,

- (d) prove that the sum of the first n terms of the series is
- $$960(1 + 0.25^n).$$
- (2)

[P1 January 2003 Question 4]

- 38.** On a journey, the average speed of a car is v m s⁻¹. For $v \geq 5$, the cost per kilometre, C pence, of the journey is modelled by

$$C = \frac{160}{v} + \frac{v^2}{100}.$$

Using this model,

- (a) show, by calculus, that there is a value of v for which C has a stationary value, and find this value of v . **(5)**
- (b) Justify that this value of v gives a minimum value of C . **(2)**
- (c) Find the minimum value of C and hence find the minimum cost of a 250 km car journey. **(3)**

[P1 January 2003 Question 5]

39.

Figure 1

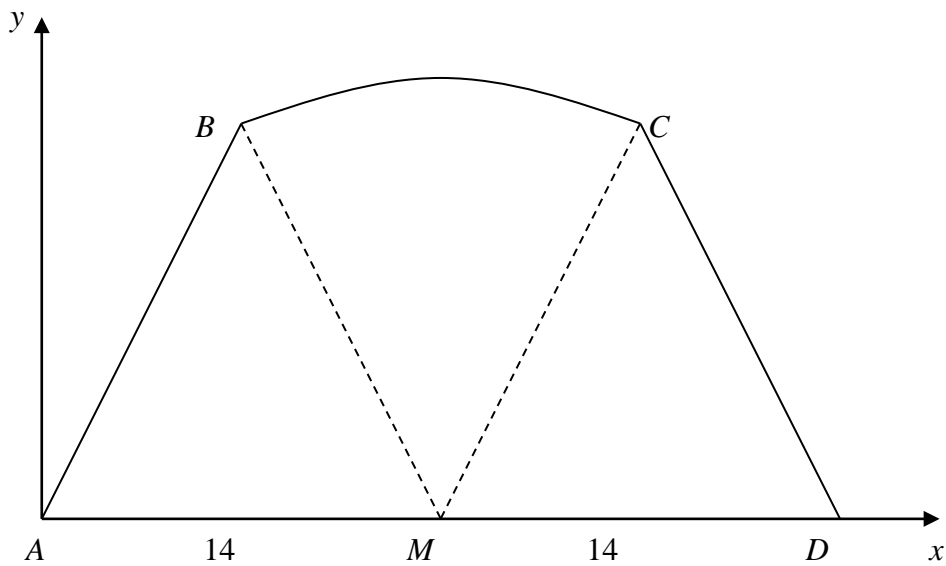

Figure 1 shows the cross-section $ABCD$ of a chocolate bar, where AB , CD and AD are straight lines and M is the mid-point of AD . The length AD is 28 mm, and BC is an arc of a circle with centre M .

Taking A as the origin, B , C and D have coordinates $(7, 24)$, $(21, 24)$ and $(28, 0)$ respectively.

- (a) Show that the length of BM is 25 mm. (1)
- (b) Show that, to 3 significant figures, $\angle BMC = 0.568$ radians. (3)
- (c) Hence calculate, in mm^2 , the area of the cross-section of the chocolate bar. (5)

Given that this chocolate bar has length 85 mm,

- (d) calculate, to the nearest cm^3 , the volume of the bar. (2)

[P1 January 2003 Question 7]

40.

Figure 2

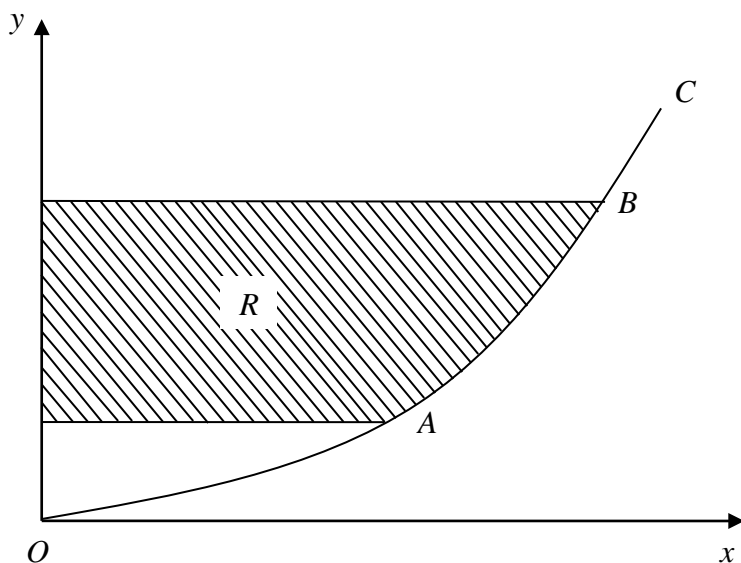

The curve C , shown in Fig. 2, represents the graph of

$$y = \frac{x^2}{25}, \quad x \geq 0.$$

The points A and B on the curve C have x -coordinates 5 and 10 respectively.

(a) Write down the y -coordinates of A and B . (1)

(b) Find an equation of the tangent to C at A . (4)

The finite region R is enclosed by C , the y -axis and the lines through A and B parallel to the x -axis.

(c) For points (x, y) on C , express x in terms of y . (2)

(d) Use integration to find the area of R . (5)

[P1 January 2003 Question 8]

41. The first three terms in the expansion, in ascending powers of x , of $(1 + px)^n$, are $1 - 18x + 36p^2x^2$. Given that n is a positive integer, find the value of n and the value of p . (7)

[P2 January 2003 Question 2]

42.

Figure 1

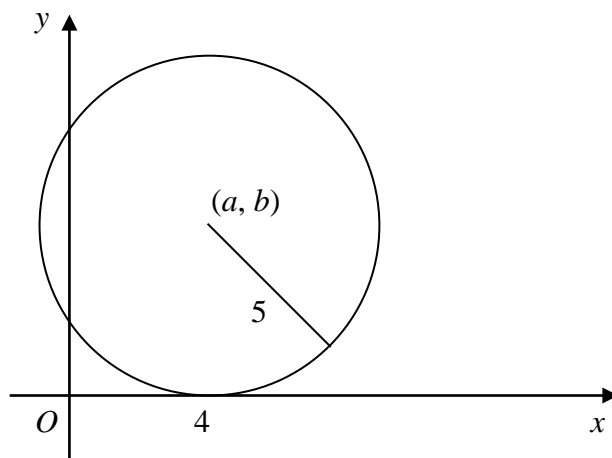

The circle C , with centre (a, b) and radius 5, touches the x -axis at $(4, 0)$, as shown in Fig. 1.

(a) Write down the value of a and the value of b . (1)

(b) Find a cartesian equation of C . (2)

A tangent to the circle, drawn from the point $P(8, 17)$, touches the circle at T .

(c) Find, to 3 significant figures, the length of PT . (3)

[P3 January 2003 Question 2]

43.

$$f(n) = n^3 + pn^2 + 11n + 9, \text{ where } p \text{ is a constant.}$$

(a) Given that $f(n)$ has a remainder of 3 when it is divided by $(n + 2)$, prove that $p = 6$. (2)

(b) Show that $f(n)$ can be written in the form $(n + 2)(n + q)(n + r) + 3$, where q and r are integers to be found. (3)

(c) Hence show that $f(n)$ is divisible by 3 for all positive integer values of n . (2)

[P3 January 2003 Question 3]

44.

Figure 1

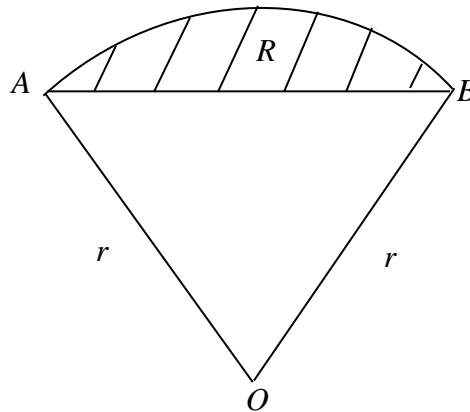

Figure 1 shows the sector OAB of a circle of radius r cm. The area of the sector is 15 cm^2 and $\angle AOB = 1.5$ radians.

(a) Prove that $r = 2\sqrt{5}$. (3)

(b) Find, in cm, the perimeter of the sector OAB . (2)

The segment R , shaded in Fig 1, is enclosed by the arc AB and the straight line AB .

(c) Calculate, to 3 decimal places, the area of R . (3)

[P1 June 2003 Question 4]

45. Find, in degrees, the value of θ in the interval $0 \leq \theta < 360^\circ$ for which

$$2\cos^2\theta - \cos\theta - 1 = \sin^2\theta.$$

Give your answers to 1 decimal place where appropriate. (8)

[P1 June 2003 Question 5]

46.

Figure 2

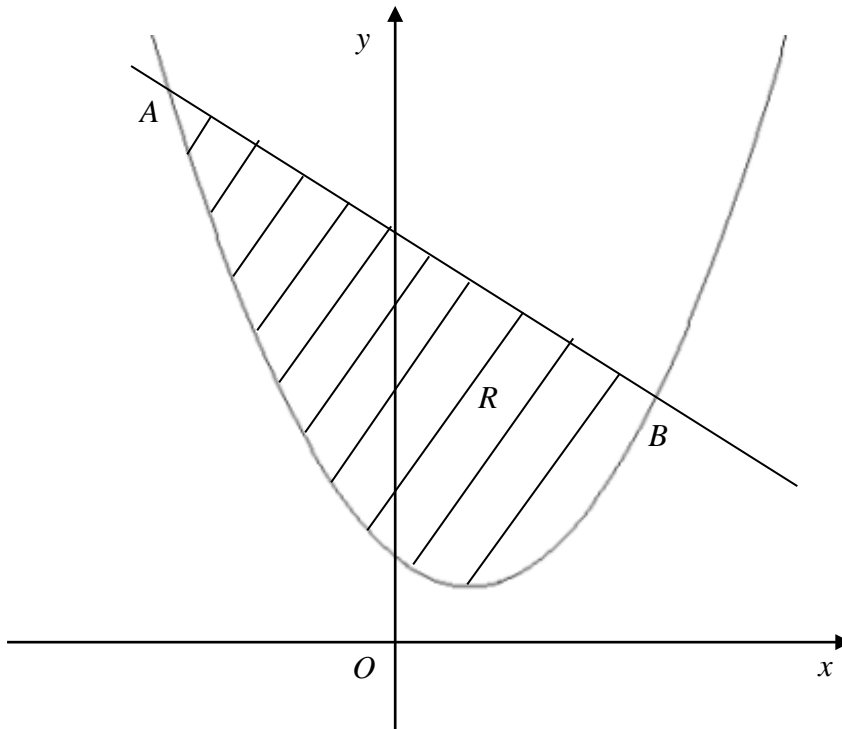

Figure 2 shows the line with equation $y = 9 - x$ and the curve with equation $y = x^2 - 2x + 3$. The line and the curve intersect at the points A and B , and O is the origin.

(a) Calculate the coordinates of A and the coordinates of B . (5)

The shaded region R is bounded by the line and the curve.

(b) Calculate the area of R . (7)

[P1 June 2003 Question 7]

47. For the curve C with equation $y = x^4 - 8x^2 + 3$,

(a) find $\frac{dy}{dx}$, (2)

(b) find the coordinates of each of the stationary points, (5)

(c) determine the nature of each stationary point. (3)

The point A , on the curve C , has x -coordinate 1.

(d) Find an equation for the normal to C at A , giving your answer in the form $ax + by + c = 0$, where a , b and c are integers. (5)

[P1 June 2003 Question 8]

48. The expansion of $(2 - px)^6$ in ascending powers of x , as far as the term in x^2 , is

$$64 + Ax + 135x^2.$$

Given that $p > 0$, find the value of p and the value of A . (7)

[P2 June 2003 Question 3]

49.
$$f(x) = px^3 + 6x^2 + 12x + q.$$

Given that the remainder when $f(x)$ is divided by $(x - 1)$ is equal to the remainder when $f(x)$ is divided by $(2x + 1)$,

(a) find the value of p . (4)

Given also that $q = 3$, and p has the value found in part (a),

(b) find the value of the remainder. (1)

[P3 June 2003 Question 2]

50. A circle C has equation

$$x^2 + y^2 - 6x + 8y - 75 = 0.$$

- (a) Write down the coordinates of the centre of C , and calculate the radius of C . (3)

A second circle has centre at the point $(15, 12)$ and radius 10.

- (b) Sketch both circles on a single diagram and find the coordinates of the point where they touch. (4)

[P3 June 2003 Question 3]

51. (a) Expand $(2\sqrt{x+3})^2$. (2)

- (b) Hence evaluate $\int_1^2 (2\sqrt{x+3})^2 dx$, giving your answer in the form $a + b\sqrt{2}$, where a and b are integers. (5)

[P1 November 2003 Question 4]

52. The curve C has equation $y = \cos\left(x + \frac{\pi}{4}\right)$, $0 \leq x \leq 2\pi$.

- (a) Sketch C . (2)

- (b) Write down the exact coordinates of the points at which C meets the coordinate axes. (3)

- (c) Solve, for x in the interval $0 \leq x \leq 2\pi$,

$$\cos\left(x + \frac{\pi}{4}\right) = 0.5,$$

- giving your answers in terms of π . (4)

[P1 November 2003 Question 5]

53. A container made from thin metal is in the shape of a right circular cylinder with height h cm and base radius r cm. The container has no lid. When full of water, the container holds 500 cm^3 of water.

(a) Show that the exterior surface area, $A \text{ cm}^2$, of the container is given by

$$A = \pi r^2 + \frac{1000}{r}. \quad (4)$$

(b) Find the value of r for which A is a minimum. (4)

(c) Prove that this value of r gives a minimum value of A . (2)

(d) Calculate the minimum value of A , giving your answer to the nearest integer. (2)

[P1 November 2003 Question 6]

54.

Figure 2

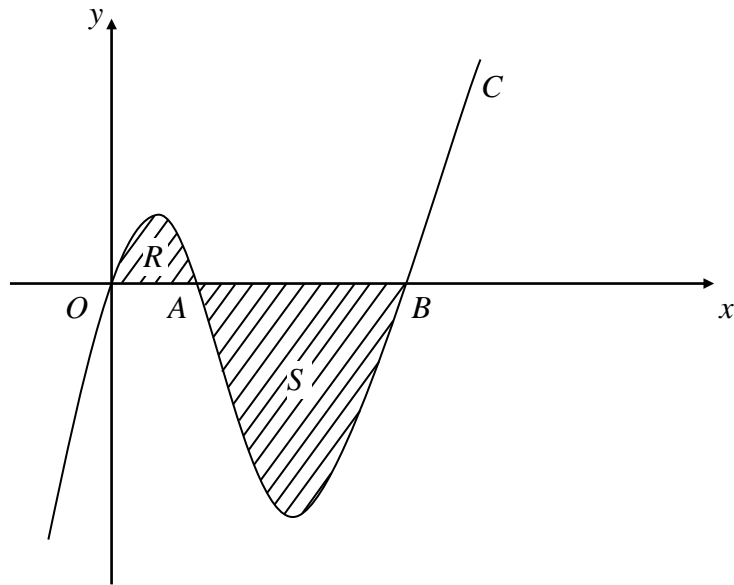

Figure 2 shows part of the curve C with equation $y = f(x)$, where

$$f(x) = x^3 - 6x^2 + 5x.$$

The curve crosses the x -axis at the origin O and at the points A and B .

- (a) Factorise $f(x)$ completely. (3)
- (b) Write down the x -coordinates of the points A and B . (1)
- (c) Find the gradient of C at A . (3)

The region R is bounded by C and the line OA , and the region S is bounded by C and the line AB .

- (d) Use integration to find the area of the combined regions R and S , shown shaded in Fig. 2. (7)

[P1 November 2003 Question 8]

55. Every £1 of money invested in a savings scheme continuously gains interest at a rate of 4% per year. Hence, after x years, the total value of an initial £1 investment is £ y , where

$$y = 1.04^x.$$

- (a) Sketch the graph of $y = 1.04^x$, $x \geq 0$. (2)
- (b) Calculate, to the nearest £, the total value of an initial £800 investment after 10 years. (2)
- (c) Use logarithms to find the number of years it takes to double the total value of any initial investment. (3)

[P2 November 2003 Question 2]

56. (a) Write down the first 4 terms of the binomial expansion, in ascending powers of x , of $(1 + ax)^n$, $n > 2$. (2)

Given that, in this expansion, the coefficient of x is 8 and the coefficient of x^2 is 30,

- (b) calculate the value of n and the value of a , (4)
- (c) find the coefficient of x^3 . (2)

[P2 November 2003 Question 3]

57.
$$f(x) = x^3 - 19x - 30.$$

- (a) Show that $(x + 2)$ is a factor of $f(x)$. (2)
- (b) Factorise $f(x)$ completely. (4)

[P1 January 2004 Question 1]

58.

Figure 1

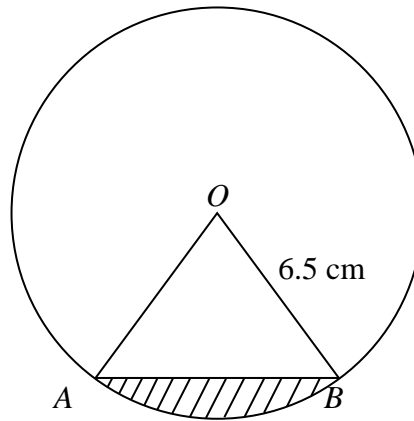

Figure 1 shows the sector AOB of a circle, with centre O and radius 6.5 cm, and $\angle AOB = 0.8$ radians.

- (a) Calculate, in cm^2 , the area of the sector AOB . (2)
- (b) Show that the length of the chord AB is 5.06 cm, to 3 significant figures. (3)

The segment R , shaded in Fig. 1, is enclosed by the arc AB and the straight line AB .

- (c) Calculate, in cm, the perimeter of R . (2)

[P1 January 2004 Question 2]

59.

Figure 3

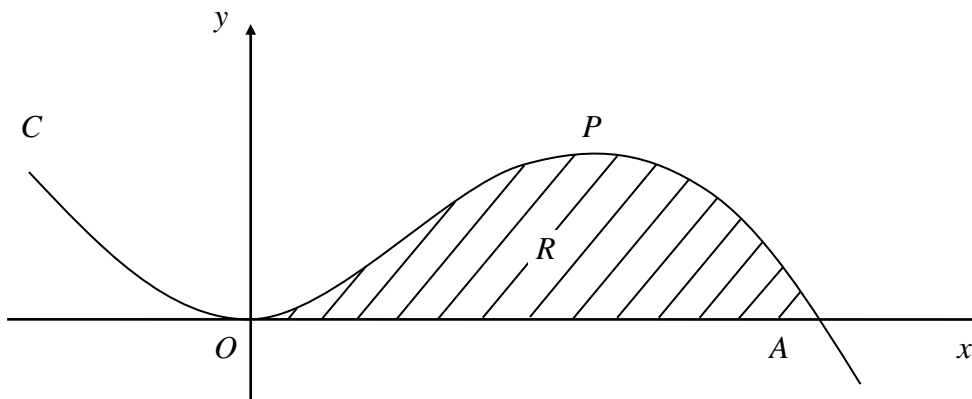

Figure 3 shows part of the curve C with equation

$$y = \frac{3}{2}x^2 - \frac{1}{4}x^3.$$

The curve C touches the x -axis at the origin and passes through the point $A(p, 0)$.

(a) Show that $p = 6$. (1)

(b) Find an equation of the tangent to C at A . (4)

The curve C has a maximum at the point P .

(c) Find the x -coordinate of P . (2)

The shaded region R , in Fig. 3, is bounded by C and the x -axis.

(d) Find the area of R . (4)

[P1 January 2004 Question 7]

60. Find all the values of θ in the interval $0 \leq \theta < 360^\circ$ for which

(a) $\cos(\theta - 10^\circ) = \cos 15^\circ$, **(3)**

(b) $\tan 2\theta = 0.4$, **(5)**

(c) $2 \sin \theta \tan \theta = 3$. **(6)**

[P1 January 2004 Question 8]

61. Given that $\log_2 x = a$, find, in terms of a , the simplest form of

(a) $\log_2(16x)$, **(2)**

(b) $\log_2\left(\frac{x^4}{2}\right)$. **(3)**

(c) Hence, or otherwise, solve

$$\log_2(16x) - \log_2\left(\frac{x^4}{2}\right) = \frac{1}{2},$$

giving your answer in its simplest surd form. **(4)**

[P2 January 2004 Question 3]

62. The point A has coordinates $(2, 5)$ and the point B has coordinates $(-2, 8)$.

Find, in cartesian form, an equation of the circle with diameter AB . **(4)**

[P3 January 2004 Question 1]

63. $f(x) = 6x^3 + px^2 + qx + 8$, where p and q are constants.

Given that $f(x)$ is exactly divisible by $(2x - 1)$, and also that when $f(x)$ is divided by $(x - 1)$ the remainder is -7 ,

(a) find the value of p and the value of q . (6)

(b) Hence factorise $f(x)$ completely. (3)

[P3 January 2004 Question 4]

64. (a) Given that $3 \sin x = 8 \cos x$, find the value of $\tan x$. (1)

(b) Find, to 1 decimal place, all the solutions of

$$3 \sin x - 8 \cos x = 0$$

in the interval $0 \leq x < 360^\circ$. (3)

(c) Find, to 1 decimal place, all the solutions of

$$3 \sin^2 y - 8 \cos y = 0$$

in the interval $0 \leq y < 360^\circ$. (6)

[P1 June 2004 Question 5]

65.
$$f(x) = \frac{(x^2 - 3)^2}{x^3}, x \neq 0.$$

(a) Show that $f(x) \equiv x - 6x^{-1} + 9x^{-3}$. (2)

(b) Hence, or otherwise, differentiate $f(x)$ with respect to x . (3)

(c) Verify that the graph of $y = f(x)$ has stationary points at $x = \pm\sqrt{3}$. (2)

(d) Determine whether the stationary value at $x = \sqrt{3}$ is a maximum or a minimum. (3)

[P1 June 2004 Question 6]

66. A geometric series is $a + ar + ar^2 + \dots$

(a) Prove that the sum of the first n terms of this series is

$$S_n = \frac{a(1-r^n)}{1-r}. \quad (4)$$

The first and second terms of a geometric series G are 10 and 9 respectively.

(b) Find, to 3 significant figures, the sum of the first twenty terms of G . (3)

(c) Find the sum to infinity of G . (2)

Another geometric series has its first term equal to its common ratio. The sum to infinity of this series is 10.

(d) Find the exact value of the common ratio of this series. (3)

[P1 June 2004 Question 7]

67.

Figure 1

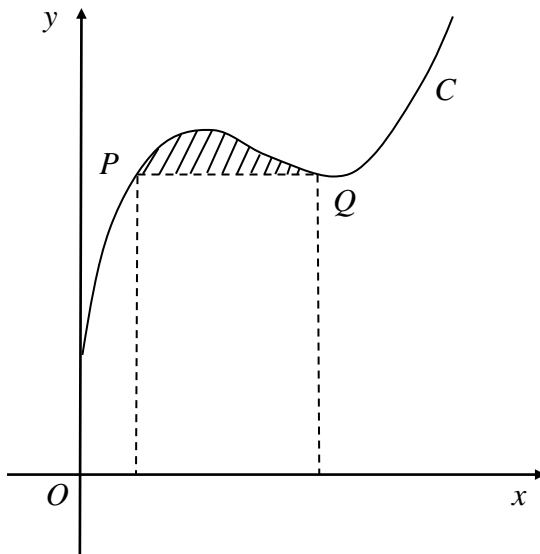

Figure 1 shows a sketch of part of the curve C with equation

$$y = x^3 - 7x^2 + 15x + 3, \quad x \geq 0.$$

The point P , on C , has x -coordinate 1 and the point Q is the minimum turning point of C .

- (a) Find $\frac{dy}{dx}$. (2)
- (b) Find the coordinates of Q . (4)
- (c) Show that PQ is parallel to the x -axis. (2)
- (d) Calculate the area, shown shaded in Fig. 1, bounded by C and the line PQ . (6)

[P1 June 2004 Question 8]

68. For the binomial expansion, in descending powers of x , of

$$\left(x^3 - \frac{1}{2x}\right)^{12},$$

(a) find the first 4 terms, simplifying each term. (5)

(b) Find, in its simplest form, the term independent of x in this expansion. (3)

[P2 June 2004 Question 3]

69. Given that $\log_5 x = a$ and $\log_5 y = b$, find in terms of a and b ,

(a) $\log_5\left(\frac{x^2}{y}\right)$, (2)

(b) $\log_5(25x\sqrt{y})$. (3)

It is given that $\log_5\left(\frac{x^2}{y}\right) = 1$ and that $\log_5(25x\sqrt{y}) = 1$.

(c) Form simultaneous equations in a and b . (1)

(d) Show that $a = -0.25$ and find the value of b . (2)

Using the value of a and b , or otherwise,

(e) calculate, to 3 decimal places, the value of x and the value of y . (3)

[P2 June 2004 Question 6]

70.

$$f(x) = (x^2 + p)(2x + 3) + 3,$$

where p is a constant.

(a) Write down the remainder when $f(x)$ is divided by $(2x + 3)$.

(1)

Given that the remainder when $f(x)$ is divided by $(x - 2)$ is 24,

(b) prove that $p = -1$,

(2)

(c) factorise $f(x)$ completely.

(4)

[P3 June 2004 Question 2]
