



# Cambridge IGCSE™

---

**GEOGRAPHY****0460/41**

Paper 4 Alternative to Coursework

**May/June 2020**

INSERT

**1 hour 30 minutes**

---

**INFORMATION**

- This insert contains additional resources referred to in the questions.
- You may annotate this insert and use the blank spaces for planning. **Do not write your answers** on the insert.

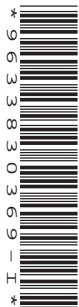

---

This document has **8** pages. Blank pages are indicated.

Fig. 1.1 for Question 1

Traditional weather station

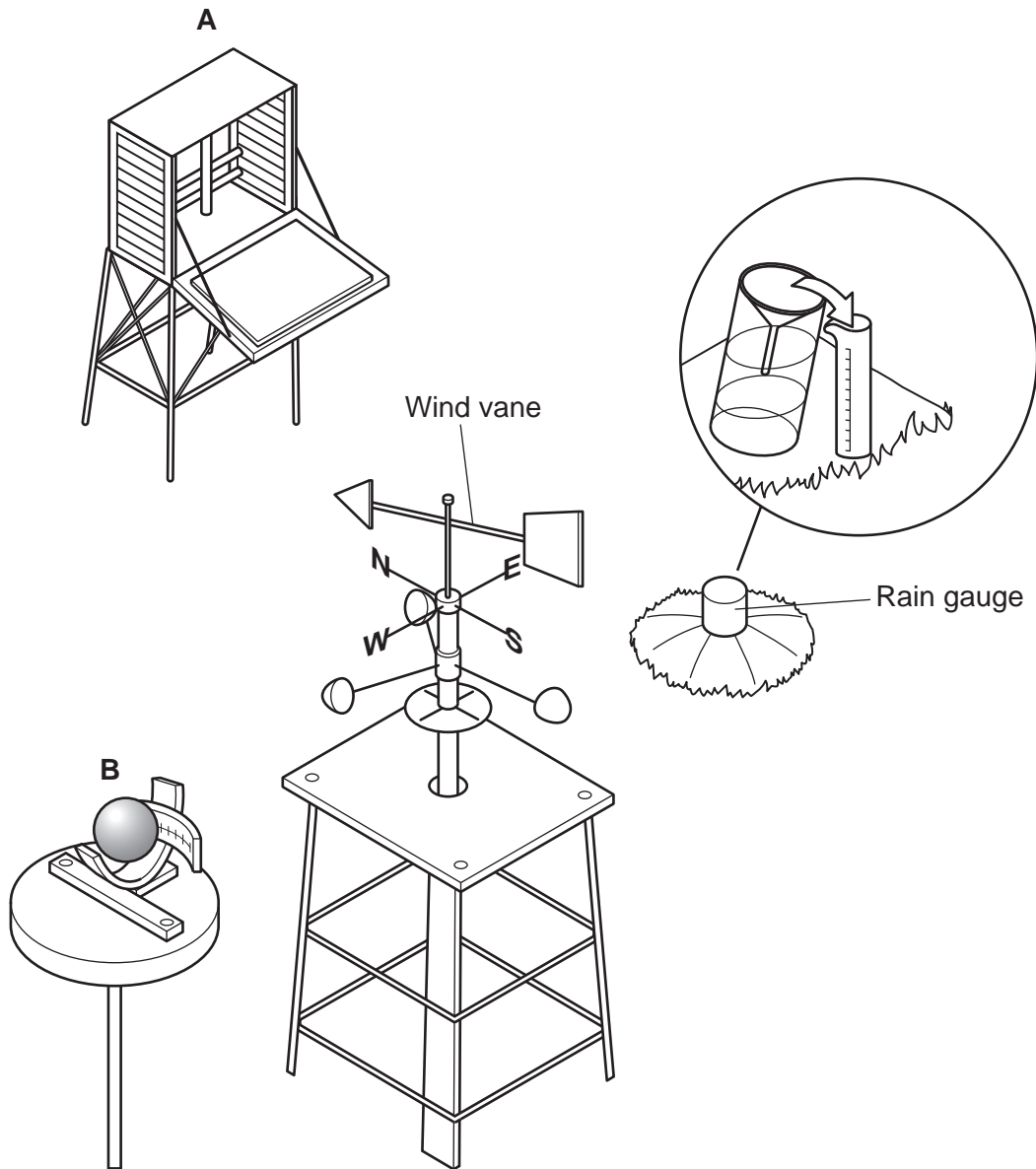

Table 1.1 for Question 1

## Results of students' measurements

	Time	Computer (C) or student (S) measured	Atmospheric pressure (mb)	Rainfall during last three hours (mm)	Direction wind comes from
Day 1	01:00	C	1011	0	N
	04:00	C	1010	0	NNW
	07:00	C	1009	0.3	N
	10:00	S	1008	0.1	N
	13:00	S	1008	0	ENE
	16:00	S	1006	0.9	NE
	19:00	S	1003	1.8	NNE
	22:00	C	1002	1.9	NNE
Day 2	01:00	C	1002	1.7	NE
	04:00	C	1000	1.8	NE
	07:00	C	999	1.8	ENE
	10:00	S	997	5.6	ENE
	13:00	S	995	5.9	NNE
	16:00	S	996	<b>4.0</b>	NNE
	19:00	S	997	7.5	NNE
	22:00	C	1000	0.2	N
Day 3	01:00	C	1002	0.3	NNW
	04:00	C	1005	0.9	NNW
	07:00	C	1006	0.6	N
	10:00	S	1008	0	NNW
	13:00	S	1010	0	WNW
	16:00	S	<b>1011</b>	0	WNW
	19:00	S	<b>1013</b>	0	NW
	22:00	C	<b>1014</b>	0	NW

4

Fig. 1.4 for Question 1

Three types of cloud

Type A



Type B



Type C

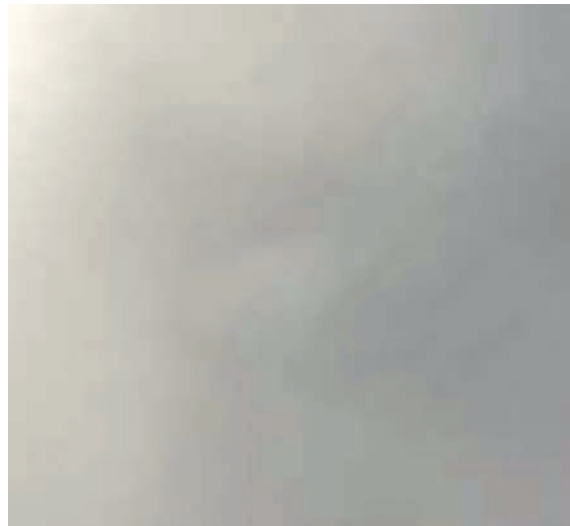

**Fig. 2.1 for Question 2****Categories of land use**

Land use category	Example of land use
Residential	terraced house, detached house, bungalow
Industrial	manufacturing, mining, assembly factory
Commercial (shops)	food, take-away, furniture, market, specialist goods
Entertainment	hotel, sports centre, theatre, cinema
Public buildings	college, hospital, place of worship, police station
Open space	farmland, park, unused land, sports field
Transport	bus station, car park, railway station
Services (offices)	financial, business, dentist, doctor, estate agent

Fig. 2.2 for Question 2

## Students' recording sheet

Distance from city centre (m)	210	220	230	240	250	260	270	280	290	300
Land use	hotel	terraced houses	clothes store	take-away	drug store (chemist)	café	semi-detached houses			
Category	entertainment	entertainment	residential	residential	commercial	commercial	commercial	entertainment	residential	residential

Distance from city centre (m)	310	320	330	340	350	360	370	380	390	400
Land use	park	greengrocer (fruit and vegetable shop)	hardware shop	supermarket	accountant	solicitor	fire and ambulance station			
Category	open space	open space	commercial	commercial	commercial	services	services	services	public	public

Fig. 2.4 for Question 2

Land use percentages along all six transects

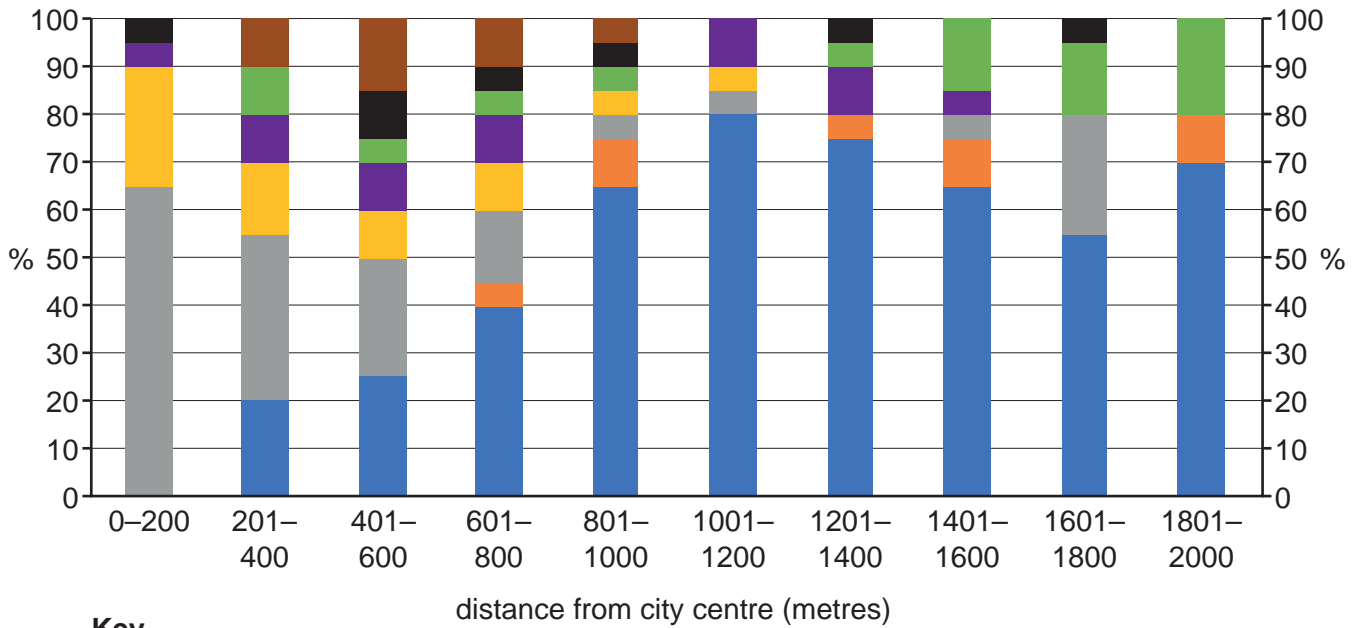

Key

Land use

- residential
- industrial
- commercial (shops)
- entertainment
- public buildings
- open space
- transport
- services (offices)

**BLANK PAGE**

---

Permission to reproduce items where third-party owned material protected by copyright is included has been sought and cleared where possible. Every reasonable effort has been made by the publisher (UCLES) to trace copyright holders, but if any items requiring clearance have unwittingly been included, the publisher will be pleased to make amends at the earliest possible opportunity.

To avoid the issue of disclosure of answer-related information to candidates, all copyright acknowledgements are reproduced online in the Cambridge Assessment International Education Copyright Acknowledgements Booklet. This is produced for each series of examinations and is freely available to download at [www.cambridgeinternational.org](http://www.cambridgeinternational.org) after the live examination series.

Cambridge Assessment International Education is part of the Cambridge Assessment Group. Cambridge Assessment is the brand name of the University of Cambridge Local Examinations Syndicate (UCLES), which itself is a department of the University of Cambridge.