

OCR

Oxford Cambridge and RSA

Accredited

...day ... Month Year – Morning/Afternoon

GCSE (9–1) Computer Science

J277/02 Computational thinking, algorithms and programming

Time allowed: 1 hour 30 minutes

Sample Question paper



Do not use:

- a calculator

Version 1.3



Please write clearly in black ink. **Do not write in the barcodes.**

Centre number

--	--	--	--	--

Candidate number

--	--	--	--

First name(s)

Last name

INSTRUCTIONS

- Use black ink.
- Write your answer to each question in the space provided. If you need extra space use the lined pages at the end of this booklet. The question numbers must be clearly shown.
- Answer **all** the questions.

INFORMATION

- The total mark for this paper is **80**.
- The marks for each question are shown in brackets [].
- This document has **20** pages.

ADVICE

- Read each question carefully before you start to answer.

BLANK PAGE

Answer **all** the questions.

Section A

- 1 (a) Complete the truth table in **Fig. 1** for the Boolean statement $P = \text{NOT}(A \text{ AND } B)$.

A	B	P
0	0	1
0	1
1	0
1	1	0

Fig. 1

[2]

- (b) Tick (✓) **one** box to identify the correct logic diagram for $P = \text{NOT}(A \text{ AND } B)$.

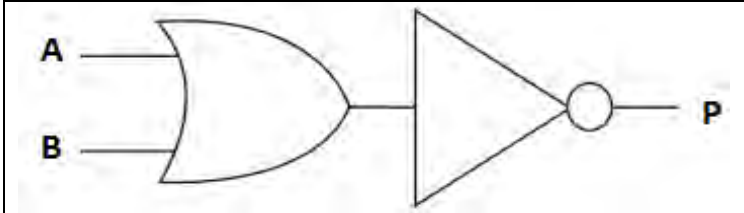
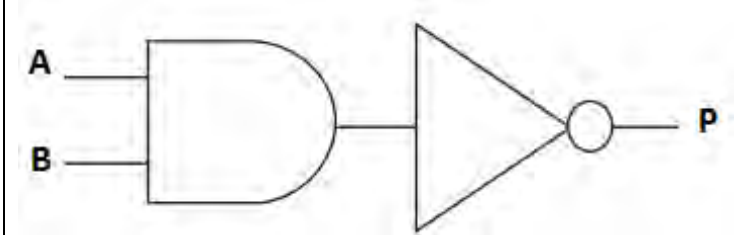
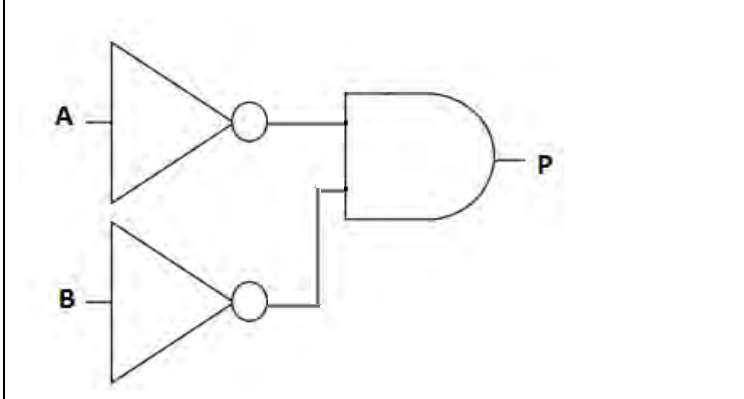
$P = \text{NOT}(A \text{ AND } B)$	Tick (✓) one box
	
	
	

[1]

- 3 The database table `Results` stores the results for each student in each of their chosen subjects.

StudentName	Subject	Grade
Alistair	English	3
Jaxon	Art	5
Alex	Art	4
Anna	French	7
Ismaael	Art	9

Complete the SQL query to return all of the fields for the students who take Art.

SELECT

FROM

WHERE

[3]

6

- 4 A program creates usernames for a school. The first design of the program is shown in the flowchart in **Fig. 2**.

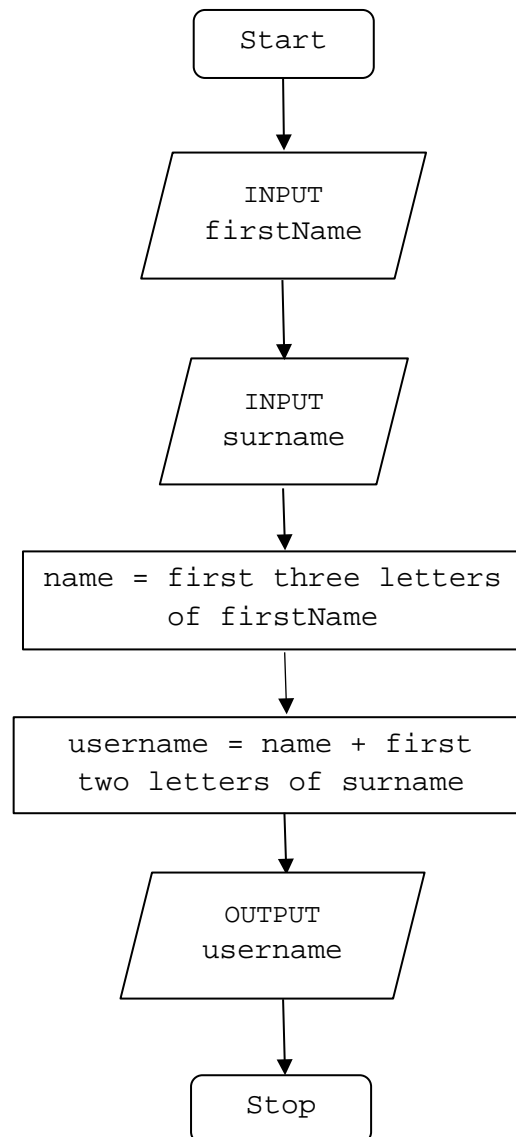

Fig. 2

For example, using the process in **Fig. 2**, Tom Ward's username would be TomWa.

(a) State, using the process in **Fig. 2**, the username for Rebecca Ellis.

..... [1]

8

5 A computer game is written in a high-level programming language.

(a) State why the computer needs to translate the code before it is executed.

..... [1]

(b) Either a compiler or an interpreter can translate the code.

Describe **two** differences between how a compiler and an interpreter would translate the code.

1

.....

.....

.....

2

.....

.....

.....

[4]

6 A program uses a file to store a list of words that can be used in a game.

A sample of this data is shown in **Fig. 3**.

crime	bait	fright	victory	nibble	loose
-------	------	--------	---------	--------	-------

Fig. 3

(a) Show the stages of a bubble sort when applied to data shown in **Fig. 3**.

.....

.....

.....

.....

.....

.....

.....

.....

.....

[4]

(b) A second sample of data is shown in **Fig. 4**.

amber	house	kick	moose	orange	range	tent	wind	zebra
-------	-------	------	-------	--------	-------	------	------	-------

Fig. 4

Show the stages of a binary search to find the word *zebra* using the data shown in **Fig. 4**.

.....

.....

.....

.....

.....

.....

.....

.....

.....

[4]

7 The area of a circle is calculated using the formula $\pi \times r^2$ where π is equal to 3.142 and r is the radius.

A program is written to allow a user to enter the radius of a circle as a whole number between 1 and 30, then calculate and output the area of the circle.

```

01 radius = 0
02 area = 0.0
03 radius = input("Enter radius")
04 if radius < 1 OR radius > 30 then
05   print("Sorry, that radius is invalid")
06 else
07   area = 3.142 * (radius ^ 2)
08   print (area)
09 endif

```

(a) Explain, using examples from the program, **two** ways to improve the maintainability of the program.

1

.....

.....

.....

.....

2

.....

.....

.....

[4]

(b) Identify **two** variables used in the program.

1

2

[2]

(c) (i) Identify **one** item in the program that could have been written as a constant.

..... [1]

(ii) Give **one** reason why you have identified this item as a constant.

..... [1]

(d) Tick (✓) **one** box in each row to identify whether each programming construct has or has **not** been used in the program.

	Has been used	Has not been used
Sequence		
Selection		
Iteration		

[3]

(e) An Integrated Development Environment (IDE) is used to write the program.

Identify **two** features of an IDE that might be used when writing the program.

1

.....

2

.....

[2]

Section B

We advise you to spend at least 40 minutes on this section.

Some questions require you to respond using either the OCR Exam Reference Language or a high-level programming language you have studied. These are clearly shown.

- 8 A teacher researches the length of time students spend playing computer games each day.
- (a) Tick (✓) **one** box to identify the data type you would choose to store the data and explain why this is a suitable data type.

Data Type	Tick (✓) one box
String	
Integer	
Real	
Boolean	

Explanation:

.....

[2]

- (b) The program should only allow values from **0** to **300** inclusive as valid inputs. If the data entered breaks this validation rule, an error message is displayed.
- (i) Complete the following program to output "Invalid input" if the data does not meet the validation rule.

You must use **either**:

- OCR Exam Reference Language, **or**
- a high-level programming language that you have studied.

```
mins = input("Enter minutes played: ")
if mins < 0 ..... mins ..... then
    ..... ("Invalid input")
endif
```

[3]

- (ii) Complete the following test plan for the program in **8(b)(i)**.

Test data	Test type	Expected result
25	Normal	Value accepted
	Invalid	Invalid input message displayed
300	Boundary	

[2]

(c) Data for one week (Monday to Friday) is stored in a 2D array with the identifier `minsPlayed`.

The following table shows part of this array, containing 4 students.

		Students				
		Stuart	Wes	Victoria	Dan	
		0	1	2	3	
Days of the week	Mon	0	60	30	45	0
	Tue	1	180	60	0	60
	Wed	2	200	30	0	20
	Thu	3	60	10	15	15
	Fri	4	100	35	30	45

The teacher wants to output the number of minutes Dan (column index 3) played computer games on Wednesday (row index 2). The following code is written:

```
print(minsPlayed[3,2])
```

Write a line of code to output the number of minutes that Stuart played computer games on Friday.

You must use **either**:

- OCR Exam Reference Language, **or**
- a high-level programming language that you have studied.

.....
 [1]

(d) The teacher writes a program to add up and print out the total number of minutes student 2 played computer games over 5 days (Monday to Friday).

```
total = 0  
  
total = total + minsPlayed[2,0]  
  
total = total + minsPlayed[2,1]  
  
total = total + minsPlayed[2,2]  
  
total = total + minsPlayed[2,3]  
  
total = total + minsPlayed[2,4]  
  
print(total)
```

Refine the program to be more efficient. Write the refined version of the algorithm.

You must use **either**:

- OCR Exam Reference Language, **or**
- a high-level programming language that you have studied.

.....
.....
.....
.....
.....
.....
.....
.....
.....
.....
.....
.....
.....
.....
.....
.....
.....
.....
.....
.....
.....

[4]

(e) The following program uses a condition-controlled loop.

```
x = 15
y = 0
while x > 0
    y = y + 1
    x = x - y
endwhile
print(y)
```

Complete the trace table to test this program.

x	y	output

[4]

- (f) A teacher writes an algorithm to store the name of the game a student plays each night (for example "OCR Zoo Simulator").

`variable.length` returns the number of characters in `variable`.

`variable.upper` returns the characters in `variable` in upper case.

```

valid = false

while(valid == false)

    gameName = input("Enter the game name")

    if (gameName.length > 0) AND (gameName.length < 20)

        gamesPlayed = gameName.upper

        valid = true

        print("Valid game name")

    else

        print("Game name is not valid")

    endif

endwhile

```

The algorithm needs testing to make sure the IF-ELSE statement works correctly.

Identify **two** different pieces of test data that can be used to test different outputs of the algorithm. Give the output from the program for each piece of test data.

Test data 1

Expected output

Test data 2

Expected output

[4]

- (g) The teacher asks students how long they spend completing homework. Students answer in minutes and hours (for example 2 hours 15 minutes).

The teacher would like to create an algorithm that will display students' inputs in minutes only.

- (i) Identify the input and output required from this algorithm.

Input

.....

Output

.....

[2]

- (ii) A program is created to convert hours and minutes into a total number of minutes.

The teacher wants to create a sub program to perform the calculation.

The program has been started but is not complete.

Complete the design for the program.

```

hours = input("Please enter number of hours played")
minutes = input("Please enter number of minutes played")
finalTotal = .....
print(finalTotal)

```

function

.....

.....

.....

.....

endfunction

[4]

(iii) The following flowchart outputs a message depending on how long each person has spent playing computer games.

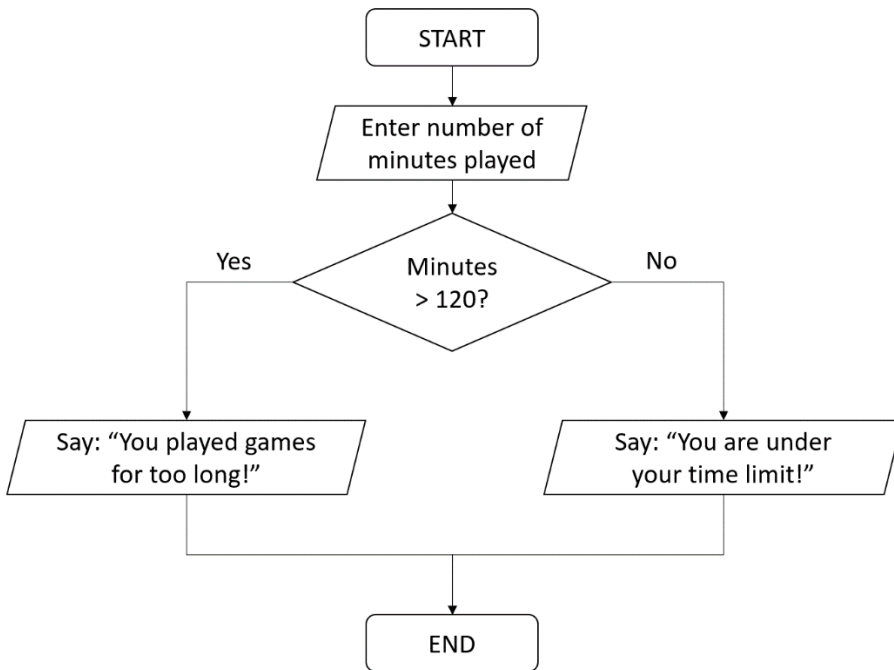

Rewrite the flowchart as a program.

You must use **either**:

- OCR Exam Reference Language, **or**
- a high-level programming language that you have studied.

.....

.....

.....

.....

.....

.....

.....

.....

.....

.....

.....

.....

.....

.....

.....

.....

.....

.....

.....

.....

.....

.....

[4]

END OF QUESTION PAPER

