

1 Some acids such as hydrochloric acid are described as strong acids.
Some acids such as ethanoic acid are described as weak acids.

(a) (i) Explain the difference between a strong acid and a weak acid.

(2)

.....

.....

.....

.....

(ii) Give a reason why adding hydroxide ions to an acid solution leads to an increase in pH.

(1)

.....

.....

(b) The salt zinc nitrate can be made by reacting zinc oxide, ZnO, with dilute nitric acid, HNO₃.

Write the balanced equation for this reaction.

(2)

.....

(c) 50 cm³ of potassium hydroxide solution of concentration 40 g dm⁻³ is needed for an experiment.

Calculate the mass of potassium hydroxide that must be dissolved in water to make 50 cm³ of solution of this concentration.

(2)

mass of potassium hydroxide = g

*(d) Salts of metals can be made by reacting one of the metal's compounds with the appropriate acid.

Plan an experiment to prepare pure, dry crystals of magnesium sulfate, MgSO_4 , by reacting a suitable magnesium compound with a suitable acid.

You may use equations if you wish.

(6)

(Total for Question 1 = 13 marks)

2 (a) Electrolysis of hydrochloric acid produces chlorine and hydrogen.

The apparatus used is shown.

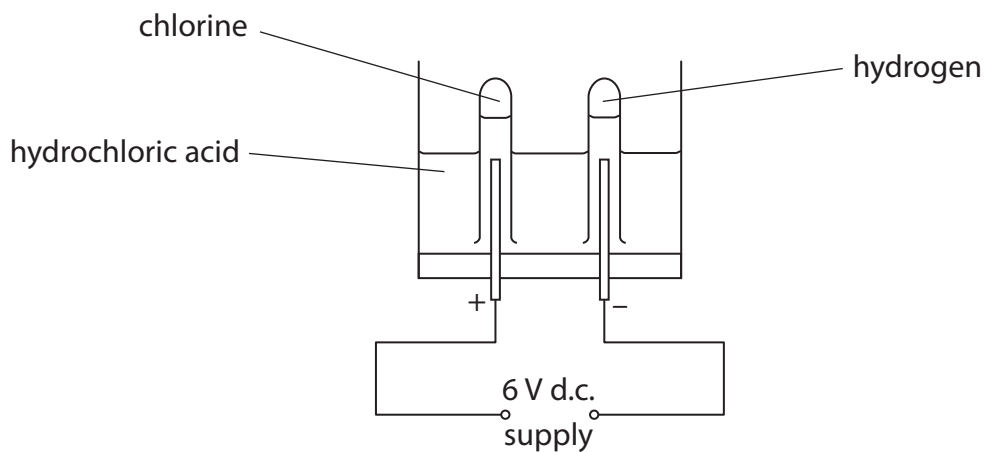

(i) Explain what is meant by **electrolysis**.

(2)

.....
.....

(ii) Describe the test to show that a gas is chlorine.

(2)

.....
.....
.....

(iii) Chlorine is used in the manufacture of a polymer.

Part of this polymer molecule is

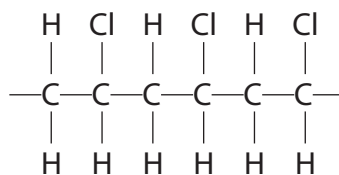

State the name of the polymer.

(1)

.....

(b) Dilute hydrochloric acid reacts with silver nitrate solution to form silver chloride and nitric acid.

(i) Complete the sentence by putting a cross (☒) in the box next to your answer.

The reaction produces silver chloride as a precipitate.
In an equation this would be shown as

(1)

A AgCl(aq)

B AgCl(g)

C AgCl(l)

D AgCl(s)

(ii) This apparatus is used to investigate the mass of the reactants and the mass of products in this reaction.

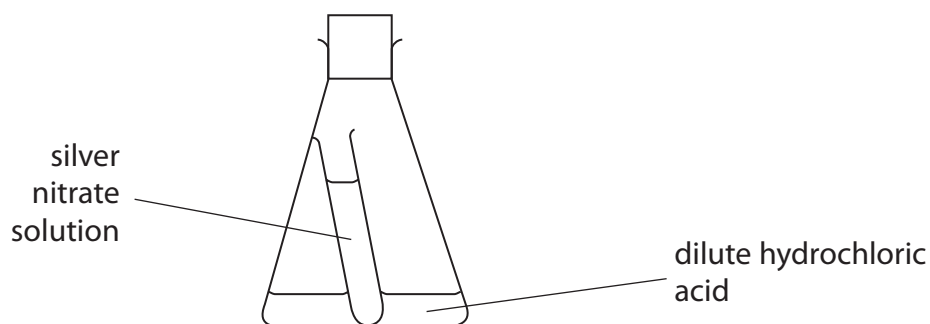

The total mass of this apparatus was measured.

The flask was shaken to allow the silver nitrate solution and dilute hydrochloric acid to react.

After the reaction the total mass of the apparatus was measured again.

State how the total mass of the apparatus after the reaction will compare with the total mass of the apparatus before the reaction.

(1)

(iii) Write the balanced equation for the reaction of silver nitrate solution, AgNO_3 , with dilute hydrochloric acid to form silver chloride, AgCl , and nitric acid.

(2)

(Total for Question 2 = 9 marks)

3 Tests can be carried out on salts to identify the ions present in the salts.

(a) (i) A flame test on a salt produces an orange-red colour.

Which ion is responsible for the orange-red colour?

Put a cross (☒) in the box next to your answer.

(1)

A calcium ion, Ca^{2+}

B copper ion, Cu^{2+}

C potassium ion, K^+

D sodium ion, Na^+

(ii) A solution of a chloride salt is acidified with dilute nitric acid.
Silver nitrate solution is added to the mixture.

Describe what is **seen** when the silver nitrate solution is added.

(2)

(b) Which of these salts is insoluble in water?

Put a cross (☒) in the box next to your answer.

(1)

A sodium carbonate

B lead chloride

C magnesium nitrate

D potassium sulfate

(c) Sodium sulfate solution and barium chloride solution are mixed.
A precipitate of barium sulfate is formed.
Another product is formed in solution.

(i) Complete the word equation for the reaction.

Include state symbols.

(2)

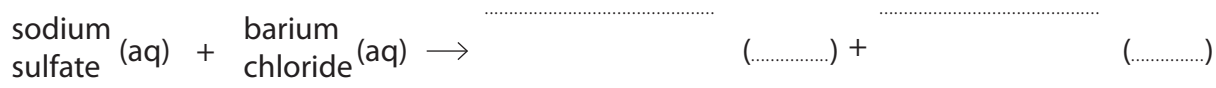

(ii) Barium salts are toxic.

Before some X-rays, patients have to swallow a suspension of barium sulfate, known as a 'barium meal'.

Explain why it is safe for these patients to swallow the barium sulfate.

(2)

.....

.....

.....

.....

.....

.....

.....

(Total for Question 3 = 8 marks)

4 Sodium carbonate and copper chloride are both ionic solids.

They are both soluble in water.

(a) Which row of the table shows the most likely melting points of these two salts?

Put a cross (☒) in the box next to your answer.

(1)

	melting point / °C	
	sodium carbonate	copper chloride
A ☒	17	498
B ☒	851	9
C ☒	851	498
D ☒	9	17

(b) Copper chloride contains copper ions, Cu^{2+} , and chloride ions, Cl^- .
Give the formula of copper chloride.

(1)

(c) Complete the sentence by putting a cross (☒) in the box next to your answer.

If a flame test is carried out on copper chloride, the colour in the flame is

(1)

- A** red-brown
- B** yellow
- C** lilac
- D** green-blue

(d) Describe how this apparatus can be used to show that sodium carbonate reacts with dilute acid to form carbon dioxide.

(3)

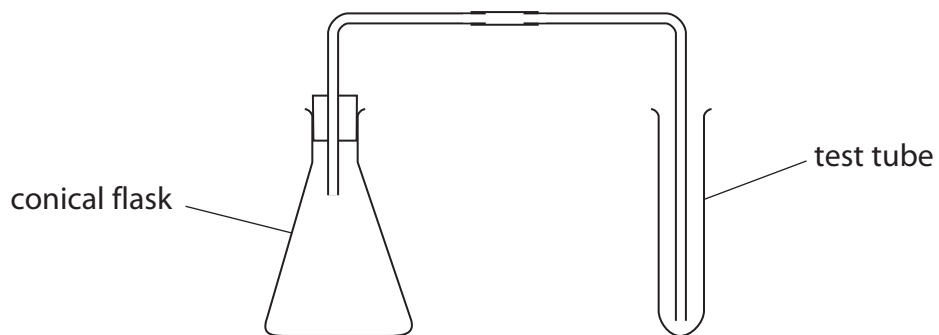

.....

.....

.....

.....

.....

.....

.....

(e) Copper carbonate is an insoluble salt.

Describe how you would use sodium carbonate and copper chloride to produce a pure, dry sample of copper carbonate.

(3)

.....

.....

.....

.....

.....

.....

.....

(Total for Question 4 = 9 marks)

5 (a) Complete the sentence by putting a cross (☒) in the box next to your answer.

When dilute hydrochloric acid reacts with copper oxide one of the products is

(1)

- A copper
- B copper hydroxide
- C copper chlorate
- D copper chloride

(b) Chlorine is manufactured by electrolysis.

Explain what is meant by **electrolysis**.

(2)

.....

.....

.....

.....

(c) Chlorine gas reacts with sodium hydroxide solution to form sodium chlorate(I), NaOCl, sodium chloride and water.

Write the balanced equation for this reaction.

(3)

.....

*(d) Sulfur is an impurity in some fossil fuels.

Explain how the presence of sulfur in fossil fuels can lead to damage to the environment and how the amount of damage can be reduced.

(6)

.....

.....

.....

.....

.....

.....

.....

.....

.....

.....

.....

.....

.....

.....

.....

.....

.....

.....

(Total for Question 5 = 12 marks)
