

- 1 One of the instructions for an experiment reads as follows.

Quickly add 50 cm^3 of acid.

What is the best piece of apparatus to use?

- A a burette
 - B a conical flask
 - C a measuring cylinder
 - D a pipette
- 2 A student uses the apparatus shown in the diagram below to measure the volume of carbon dioxide gas made when different masses of marble chips are added to 25 cm^3 of dilute hydrochloric acid.

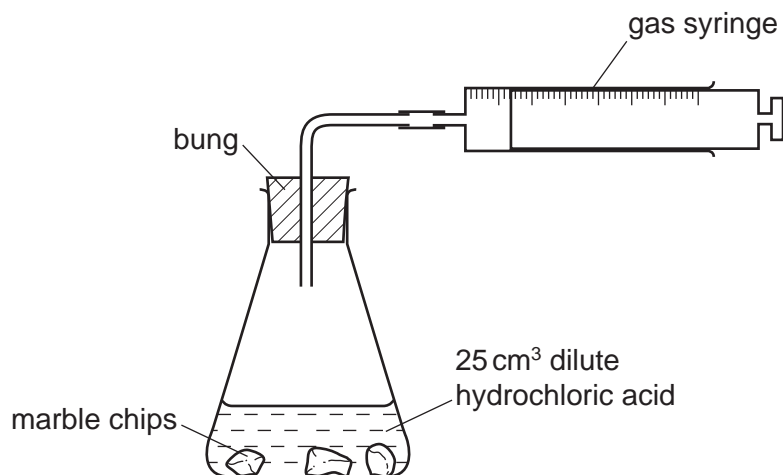

Which other items of apparatus are needed?

- A funnel and balance
- B funnel and stopwatch
- C measuring cylinder and balance
- D measuring cylinder and stopwatch

3 The diagram shows three pieces of apparatus that are used for measuring the volume of a liquid.

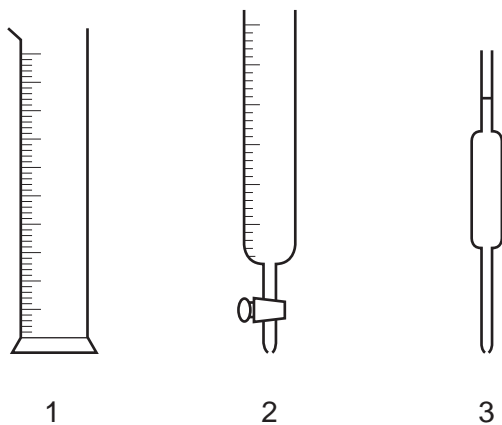

What are these pieces of apparatus?

	1	2	3
A	burette	measuring cylinder	pipette
B	burette	pipette	measuring cylinder
C	measuring cylinder	burette	pipette
D	measuring cylinder	pipette	burette

- 4 The four pieces of apparatus shown below are used in chemical experiments.

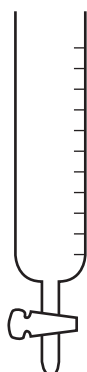

burette

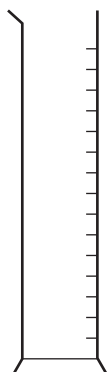

measuring
cylinder



pipette



thermometer

Which statement about the apparatus is correct?

- A The burette measures the volume of liquid added in a titration.
 - B The measuring cylinder measures the mass of a substance used in an experiment.
 - C The pipette measures the volume of gas given off in a reaction.
 - D The thermometer measures the density of a solution.
- 5 A student measures the rate of two reactions.

In one reaction, there is a change in mass of the reactants during the reaction.

In the second reaction, there is a change in temperature during the reaction.

Which piece of apparatus would be essential in **both** experiments?

- A balance
- B clock
- C pipette
- D thermometer

6 Crystals of sodium chloride were prepared by the following method.

- 1 25.0 cm³ of dilute hydrochloric acid was accurately measured into a conical flask.
- 2 Aqueous sodium hydroxide was added until the solution was neutral. The volume of sodium hydroxide added was measured.
- 3 The solution was evaporated and the crystals washed with approximately 15 cm³ of water.

Which row shows the pieces of apparatus used to measure the 25.0 cm³ of hydrochloric acid, the volume of aqueous sodium hydroxide and the 15 cm³ of water?

	25.0 cm ³ of hydrochloric acid accurately	the volume of aqueous sodium hydroxide added	15 cm ³ of water approximately
A	burette	pipette	measuring cylinder
B	measuring cylinder	burette	pipette
C	pipette	burette	measuring cylinder
D	pipette	measuring cylinder	burette

7 Lead iodide is insoluble in water.

Lead iodide is made by adding aqueous lead nitrate to aqueous potassium iodide.

Which pieces of apparatus are needed to obtain solid lead iodide from 20 cm³ of aqueous lead nitrate?



1

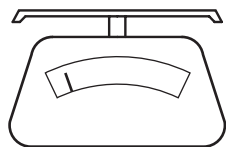

2

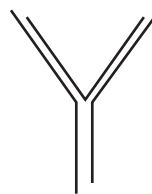
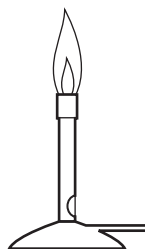

4



A 1, 2

B 1, 3 and 5

C 1, 4 and 5

D 2, 4 and 5

- 8 The diagram shows an experiment to find the formula of magnesium oxide.

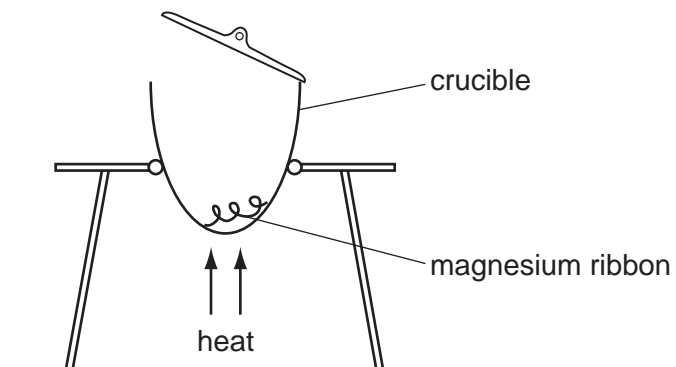

Which piece of apparatus would be needed in addition to those shown?

- A a balance
 - B a measuring cylinder
 - C a spatula
 - D a thermometer
- 9 Part of the instructions in an experiment reads as follows.

Quickly add 50 cm^3 of acid.

What is the best piece of apparatus to use?

- A a burette
- B a conical flask
- C a measuring cylinder
- D a pipette

- 10 A student investigates how the concentration of an acid affects the speed of reaction with a 0.5 g mass of magnesium at 30 °C.

The student has a beaker, concentrated acid, water and the apparatus below.

- P a balance
- Q a clock
- R a measuring cylinder
- S a thermometer

Which pieces of apparatus does the student use?

- A P, Q and R only
 - B P, Q and S only
 - C Q, R and S only
 - D P, Q, R and S
- 11 A student was provided with only a thermometer, a stopwatch and a beaker.

What could the student measure?

- A 10.5g solid and 24.8 cm³ liquid
- B 10.5g solid and 25 °C
- C 24.8 cm³ liquid and 45 seconds
- D 25 °C and 45 seconds

- 12 A student carries out an experiment to find how fast 3 cm pieces of magnesium ribbon dissolve in 10 cm³ samples of sulfuric acid at different temperatures.

Which piece of apparatus does the student **not** need?

- A balance
- B measuring cylinder
- C stop-clock
- D thermometer

- 13 A student takes 2 g samples of calcium carbonate and adds them to 20 cm³ samples of dilute hydrochloric acid at different temperatures. She measures how long it takes for the effervescence to stop.

Which apparatus does she use?

	balance	clock	filter funnel	measuring cylinder	thermometer
A	✓	✓	✓	✓	x
B	✓	✓	x	✓	✓
C	✓	x	✓	✓	✓
D	x	✓	✓	x	✓

14

P, Q, R and S are pieces of apparatus.

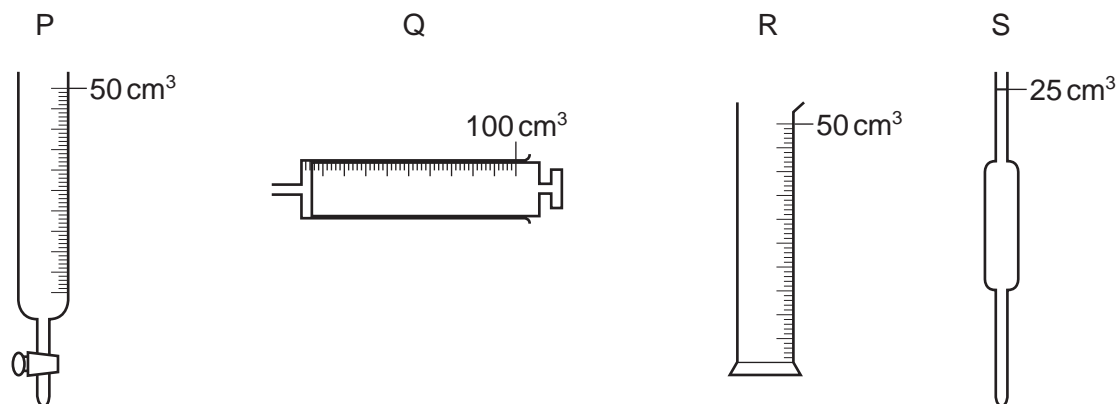

Which row describes the correct apparatus for the measurement made?

	apparatus	measurement made
A	P	the volume of acid added to alkali in a titration
B	Q	1 cm ³ of acid to add to calcium carbonate in a rate-determining experiment
C	R	75 cm ³ of a gas given off in a rate-determining experiment
D	S	20 cm ³ of alkali for use in a titration

15 During a reaction, the following changes take place.

- 1 The temperature rises.
- 2 A gas is given off.

Which apparatus is required to measure the rate of this reaction?

- A** balance and burette
- B** balance and gas syringe
- C** gas syringe and burette
- D** gas syringe and stopclock